



MICROCHIP

# 93LC46/56/66

## 1K/2K/4K 2.0V Microwire® Serial EEPROM

### FEATURES

- Single supply with programming operation down to 2.0V (Commercial only)
- Low power CMOS technology
  - 1 mA active current typical
  - 5 µA standby current (typical) at 3.0V
- ORG pin selectable memory configuration
  - 128 x 8 or 64 x 16-bit organization (93LC46)
  - 256 x 8 or 128 x 16-bit organization (93LC56)
  - 512 x 8 or 256 x 16-bit organization (93LC66)
- Self-timed ERASE and WRITE cycles (including auto-erase)
- Automatic ERAL before WRAL
- Power on/off data protection circuitry
- Industry standard 3-wire serial I/O
- Device status signal during ERASE/WRITE cycles
- Sequential READ function
- 10,000,000 ERASE/WRITE cycles guaranteed on 93LC56 and 93LC66
- 1,000,000 E/W cycles guaranteed on 93LC46
- Data retention > 200 years
- 8-pin PDIP/SOIC and 14-pin SOIC package (SOIC in JEDEC and EIAJ standards)
- Temperature ranges supported
  - Commercial (C): 0°C to +70°C
  - Industrial (I): -40°C to +85°C

### BLOCK DIAGRAM

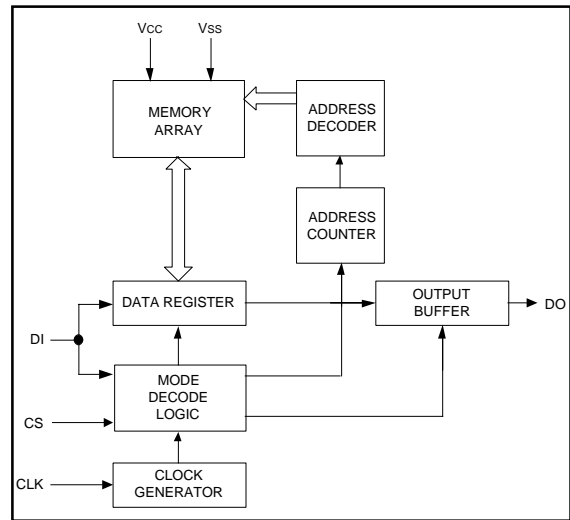

### DESCRIPTION

The Microchip Technology Inc. 93LC46/56/66 are 1K, 2K, and 4K low-voltage serial Electrically Erasable PROMs. The device memory is configured as x8 or x16 bits, depending on the ORG pin setup. Advanced CMOS technology makes these devices ideal for low-power, nonvolatile memory applications. The 93LC46/56/66 is available in standard 8-pin DIP and 8/14-pin surface mount SOIC packages. The 93LC46X/56X/66X are only offered in an "SN" package.

### PACKAGE TYPES

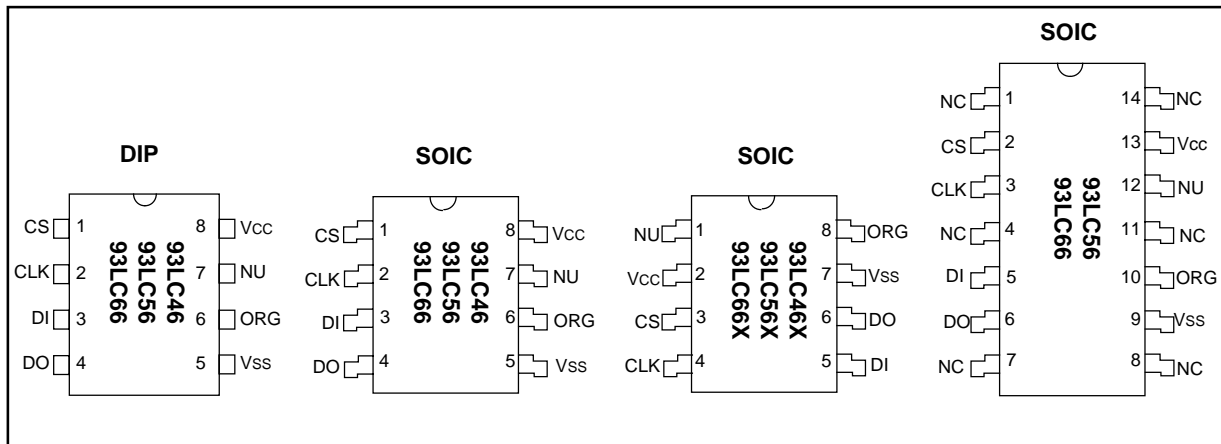

# 93LC46/56/66

## 1.0 ELECTRICAL CHARACTERISTICS

### 1.1 Maximum Ratings\*

V<sub>CC</sub> ..... 7.0V  
 All inputs and outputs w.r.t. V<sub>SS</sub> ..... -0.6V to V<sub>CC</sub> +1.0V  
 Storage temperature ..... -65°C to +150°C  
 Ambient temp. with power applied..... -65°C to +125°C  
 Soldering temperature of leads (10 seconds) ..... +300°C  
 ESD protection on all pins..... 4 kV

\*Notice: Stresses above those listed under "Maximum ratings" may cause permanent damage to the device. This is a stress rating only and functional operation of the device at those or any other conditions above those indicated in the operational listings of this specification is not implied. Exposure to maximum rating conditions for extended periods may affect device reliability.

PIN function Table

Name	Function
CS	Chip Select
CLK	Serial Data Clock
DI	Serial Data Input
DO	Serial Data Output
V <sub>SS</sub>	Ground
ORG	Memory Configuration
NU	Not Utilized
NC	No Connect
V <sub>CC</sub>	Power Supply

TABLE 1-1 DC AND AC ELECTRICAL CHARACTERISTICS

Commercial (C): V <sub>CC</sub> = +2.0V to +6.0V (C): Tamb = 0°C to +70°C Industrial (I): V <sub>CC</sub> = +2.5V to +6.0V (I): Tamb = -40°C to +85°C					
Parameter	Symbol	Min.	Max.	Units	Conditions
High level input voltage	V <sub>IH1</sub>	2.0	V <sub>CC</sub> +1	V	V <sub>CC</sub> ≥ 2.7V
	V <sub>IH2</sub>	0.7 V <sub>CC</sub>	V <sub>CC</sub> +1	V	V <sub>CC</sub> < 2.7V
Low level input voltage	V <sub>IL1</sub>	-0.3	0.8	V	V <sub>CC</sub> ≥ 2.7V
	V <sub>IL2</sub>	-0.3	0.2 V <sub>CC</sub>	V	V <sub>CC</sub> < 2.7V
Low level output voltage	V <sub>OL1</sub>	—	0.4	V	I <sub>OL</sub> = 2.1 mA; V <sub>CC</sub> = 4.5V
	V <sub>OL2</sub>	—	0.2	V	I <sub>OL</sub> = 100 μA; V <sub>CC</sub> = V <sub>CC</sub> Min.
High level output voltage	V <sub>OH1</sub>	2.4	—	V	I <sub>OH</sub> = -400 μA; V <sub>CC</sub> = 4.5V
	V <sub>OH2</sub>	V <sub>CC</sub> -0.2	—	V	I <sub>OH</sub> = -100 μA; V <sub>CC</sub> = V <sub>CC</sub> Min.
Input leakage current	I <sub>LI</sub>	-10	10	μA	V <sub>IN</sub> = 0.1V to V <sub>CC</sub>
Output leakage current	I <sub>LO</sub>	-10	10	μA	V <sub>OUT</sub> = 0.1V to V <sub>CC</sub>
Pin capacitance (all inputs/outputs)	C <sub>IN</sub> , C <sub>OUT</sub>	—	7	pF	V <sub>IN</sub> /V <sub>OUT</sub> = 0 V (Notes 1 & 3) Tamb = +25°C, F <sub>CLK</sub> = 1 MHz
Operating current	I <sub>CC</sub> read	—	1 500	mA μA	F <sub>CLK</sub> = 2 MHz; V <sub>CC</sub> = 6.0V F <sub>CLK</sub> = 1 MHz; V <sub>CC</sub> = 3.0V
	I <sub>CC</sub> write	—	3	mA	F <sub>CLK</sub> = 2 MHz; V <sub>CC</sub> = 6.0V (Note 3)
Standby current	I <sub>CCS</sub>	—	100	μA	CLK = CS = 0V; V <sub>CC</sub> = 6.0V
			30	μA	CLK = CS = 0V; V <sub>CC</sub> = 3.0V
Clock frequency	F <sub>CLK</sub>	—	2	MHz	V <sub>CC</sub> ≥ 4.5V
			1	MHz	V <sub>CC</sub> < 4.5V
Clock high time	T <sub>CKH</sub>	250	—	ns	
Clock low time	T <sub>CKL</sub>	250	—	ns	
Chip select setup time	T <sub>CSS</sub>	50	—	ns	Relative to CLK
Chip select hold time	T <sub>CSH</sub>	0	—	ns	Relative to CLK
Chip select low time	T <sub>CSL</sub>	250	—	ns	
Data input setup time	T <sub>DIS</sub>	100	—	ns	Relative to CLK
Data input hold time	T <sub>DIH</sub>	100	—	ns	Relative to CLK
Data output delay time	T <sub>PD</sub>	—	400	ns	C <sub>L</sub> = 100 pF
Data output disable time	T <sub>CZ</sub>	—	100	ns	C <sub>L</sub> = 100 pF (Note 3)
Status valid time	T <sub>SV</sub>	—	500	ns	C <sub>L</sub> = 100 pF
Program cycle time	T <sub>WC</sub>	—	10	ms	ERASE/WRITE mode (Note 2)
	T <sub>EC</sub>	—	15	ms	ERAL mode
	T <sub>WL</sub>	—	30	ms	WRAL mode
Endurance					
93LC46	—	1M	—	cycles	25°C, V <sub>CC</sub> = 5.0V, Block Mode (Note 4)
93LC56/66	—	10M	—		

Note 1: This parameter is tested at Tamb = 25°C and F<sub>CLK</sub> = 1 MHz.

2: Typical program cycle time is 4 ms per word.

3: This parameter is periodically sampled and not 100% tested.

4: This application is not tested but guaranteed by characterization. For endurance estimates in a specific application, please consult the Total Endurance Model which can be obtained on our BBS or website.

## 2.0 PIN DESCRIPTION

### 2.1 Chip Select (CS)

A high level selects the device. A low level deselects the device and forces it into standby mode. However, a programming cycle which is already initiated and/or in progress will be completed, regardless of the CS input signal. If CS is brought low during a program cycle, the device will go into standby mode as soon as the programming cycle is completed.

CS must be low for 250 ns minimum ( $T_{CSL}$ ) between consecutive instructions. If CS is low, the internal control logic is held in a RESET status.

### 2.2 Serial Clock (CLK)

The Serial Clock (CLK) is used to synchronize the communication between a master device and the 93LCXX. Opcodes, addresses, and data bits are clocked in on the positive edge of CLK. Data bits are also clocked out on the positive edge of CLK.

CLK can be stopped anywhere in the transmission sequence (at high or low level) and can be continued anytime with respect to clock high time ( $T_{CKH}$ ) and clock low time ( $T_{CKL}$ ). This gives the controlling master freedom in preparing the opcode, address, and data.

CLK is a "Don't Care" if CS is low (device deselected). If CS is high, but the START condition has not been detected, any number of clock cycles can be received by the device without changing its status (i.e., waiting for a START condition).

CLK cycles are not required during the self-timed WRITE (i.e., auto ERASE/WRITE) cycle.

After detecting a START condition, the specified number of clock cycles (respectively low to high transitions of CLK) must be provided. These clock cycles are required to clock in all required opcodes, addresses, and data bits before an instruction is executed (Table 2-1 to Table 2-6). CLK and DI then become don't care inputs waiting for a new START condition to be detected.

**Note:** CS must go low between consecutive instructions.

### 2.3 Data In (DI)

Data In (DI) is used to clock in a START bit, opcode, address, and data synchronously with the CLK input.

### 2.4 Data Out (DO)

Data Out (DO) is used in the READ mode to output data synchronously with the CLK input ( $T_{PD}$  after the positive edge of CLK).

This pin also provides  $READY/\overline{BUSY}$  status information during ERASE and WRITE cycles.  $READY/\overline{BUSY}$  status information is available on the DO pin if CS is brought high after being low for minimum chip select low time ( $T_{CSL}$ ) and an ERASE or WRITE operation has been initiated.

The status signal is not available on DO, if CS is held low or high during the entire WRITE or ERASE cycle. In all other cases DO is in the HIGH-Z mode. If status is checked after the ERASE/WRITE cycle, a pull-up resistor on DO is required to read the  $READY$  signal.

### 2.5 Organization (ORG)

When ORG is tied to  $V_{SS}$ , the (x8) memory organization is selected. When ORG is connected to  $V_{CC}$  or floated, the (x16) memory organization is selected. ORG can only be floated for clock speeds of 1 MHz or less for the (X16) memory organization. For clock speeds greater than 1 MHz, ORG must be tied to  $V_{CC}$  or  $V_{SS}$ .

# 93LC46/56/66

**TABLE 2-1 INSTRUCTION SET FOR 93LC46: ORG = 0 (X 8 ORGANIZATION)**

Instruction	SB	Opcode	Address	Data In	Data Out	Req. CLK Cycles
ERASE	1	11	A6 A5 A4 A3 A2 A1 A0	—	(RDY/BSY)	10
ERAL	1	00	1 0 X X X X X	—	(RDY/BSY)	10
EWDS	1	00	0 0 X X X X X	—	HIGH-Z	10
EWEN	1	00	1 1 X X X X X	—	HIGH-Z	10
READ	1	10	A6 A5 A4 A3 A2 A1 A0	—	D7 - D0	18
WRITE	1	01	A6 A5 A4 A3 A2 A1 A0	D7 - D0	(RDY/BSY)	18
WRAL	1	00	0 1 X X X X X	D7 - D0	(RDY/BSY)	18

**TABLE 2-2 INSTRUCTION SET FOR 93LC46: ORG = 1 (X 16 ORGANIZATION)**

Instruction	SB	Opcode	Address	Data In	Data Out	Req. CLK Cycles
ERASE	1	11	A5 A4 A3 A2 A1 A0	—	(RDY/BSY)	9
ERAL	1	00	1 0 X X X X X	—	(RDY/BSY)	9
EWDS	1	00	0 0 X X X X X	—	HIGH-Z	9
EWEN	1	00	1 1 X X X X X	—	HIGH-Z	9
READ	1	10	A5 A4 A3 A2 A1 A0	—	D15 - D0	25
WRITE	1	01	A5 A4 A3 A2 A1 A0	D15 - D0	(RDY/BSY)	25
WRAL	1	00	0 1 X X X X X	D15 - D0	(RDY/BSY)	25

**TABLE 2-3 INSTRUCTION SET FOR 93LC56: ORG = 0 (X 8 ORGANIZATION)**

Instruction	SB	Opcode	Address	Data In	Data Out	Req. CLK Cycles
ERASE	1	11	X A7 A6 A5 A4 A3 A2 A1 A0	—	(RDY/BSY)	12
ERAL	1	00	1 0 X X X X X X X	—	(RDY/BSY)	12
EWDS	1	00	0 0 X X X X X X X	—	HIGH-Z	12
EWEN	1	00	1 1 X X X X X X X	—	HIGH-Z	12
READ	1	10	X A7 A6 A5 A4 A3 A2 A1 A0	—	D7 - D0	20
WRITE	1	01	X A7 A6 A5 A4 A3 A2 A1 A0	D7 - D0	(RDY/BSY)	20
WRAL	1	00	0 1 X X X X X X X	D7 - D0	(RDY/BSY)	20

**TABLE 2-4 INSTRUCTION SET FOR 93LC56: ORG = 1 (X 16 ORGANIZATION)**

Instruction	SB	Opcode	Address	Data In	Data Out	Req. CLK Cycles
ERASE	1	11	X A6 A5 A4 A3 A2 A1 A0	—	(RDY/BSY)	11
ERAL	1	00	1 0 X X X X X X X	—	(RDY/BSY)	11
EWDS	1	00	0 0 X X X X X X X	—	HIGH-Z	11
EWEN	1	00	1 1 X X X X X X X	—	HIGH-Z	11
READ	1	10	X A6 A5 A4 A3 A2 A1 A0	—	D15 - D0	27
WRITE	1	01	X A6 A5 A4 A3 A2 A1 A0	D15 - D0	(RDY/BSY)	27
WRAL	1	00	0 1 X X X X X X X	D15 - D0	(RDY/BSY)	27

**TABLE 2-5 INSTRUCTION SET FOR 93LC66: ORG = 0 (X 8 ORGANIZATION)**

Instruction	SB	Opcode	Address	Data In	Data Out	Req. CLK Cycles
ERASE	1	11	A8 A7 A6 A5 A4 A3 A2 A1 A0	—	(RDY/BSY)	12
ERAL	1	00	1 0 X X X X X X X	—	(RDY/BSY)	12
EWDS	1	00	0 0 X X X X X X X	—	HIGH-Z	12
EWEN	1	00	1 1 X X X X X X X	—	HIGH-Z	12
READ	1	10	A8 A7 A6 A5 A4 A3 A2 A1 A0	—	D7 - D0	20
WRITE	1	01	A8 A7 A6 A5 A4 A3 A2 A1 A0	D7 - D0	(RDY/BSY)	20
WRAL	1	00	0 1 X X X X X X X	D7 - D0	(RDY/BSY)	20

**TABLE 2-6 INSTRUCTION SET FOR 93LC66: ORG = 1 (X 16 ORGANIZATION)**

Instruction	SB	Opcode	Address	Data In	Data Out	Req. CLK Cycles
READ	1	10	A7 A6 A5 A4 A3 A2 A1 A0	—	D15 - D0	27
EWEN	1	00	1 1 X X X X X X X	—	High-Z	11
ERASE	1	11	A7 A6 A5 A4 A3 A2 A1 A0	—	(RDY/BSY)	11
ERAL	1	00	1 0 X X X X X X X	—	(RDY/BSY)	11
WRITE	1	01	A7 A6 A5 A4 A3 A2 A1 A0	D15 - D0	(RDY/BSY)	27
WRAL	1	00	0 1 X X X X X X X	D15 - D0	(RDY/BSY)	27
EWDS	1	00	0 0 X X X X X X X	—	High-Z	11

## 3.0 FUNCTIONAL DESCRIPTION

When it is connected to ground, the (x8) organization is selected. When the ORG pin is connected to Vcc, the (x16) organization is selected. Instructions, addresses and write data are clocked into the DI pin on the rising edge of the clock (CLK). The DO pin is normally held in a HIGH-Z state, except when reading data from the device or when checking the  $\overline{\text{READY}}/\overline{\text{BUSY}}$  status during a programming operation. The  $\overline{\text{READY}}/\overline{\text{BUSY}}$  status can be verified during an ERASE/WRITE operation by polling the DO pin; DO low indicates that programming is still in progress, while DO high indicates the device is ready. The DO will enter the HIGH-Z state on the falling edge of the CS.

### 3.1 START Condition

The START bit is detected by the device if CS and DI are both high with respect to the positive edge of CLK for the first time.

Before a START condition is detected, CS, CLK, and DI may change in any combination (except to that of a START condition), without resulting in any device operation (READ, WRITE, ERASE, EWEN, EWDS, ERAL, and WRAL). As soon as CS is high, the device is no longer in the standby mode.

An instruction following a START condition will only be executed if the required amount of opcodes, addresses, and data bits for any particular instruction is clocked in.

After execution of an instruction (i.e., clock in or out of the last required address or data bit) CLK and DI become don't care bits until a new START condition is detected.

### 3.2 Data In (DI) and Data Out (DO)

It is possible to connect the Data In (DI) and Data Out (DO) pins together. However, with this configuration, if A0 is a logic-high level, it is possible for a "bus conflict" to occur during the "dummy zero" that precedes the READ operation. Under such a condition the voltage level seen at DO is undefined and will depend upon the relative impedances of Data Out, and the signal source driving A0. The higher the current sourcing capability of A0, the higher the voltage at the DO pin.

### 3.3 Data Protection

During power-up, all programming modes of operation are inhibited until Vcc has reached a level greater than 1.4V. During power-down, the source data protection circuitry acts to inhibit all programming modes when Vcc has fallen below 1.4V at nominal conditions.

The ERASE/WRITE Disable (EWDS) and ERASE/WRITE Enable (EWEN) commands give additional protection against accidentally programming during normal operation.

After power-up, the device is automatically in the EWDS mode. Therefore, an EWEN instruction must be performed before any ERASE or WRITE instruction can be executed.

**FIGURE 3-1: SYNCHRONOUS DATA TIMING**

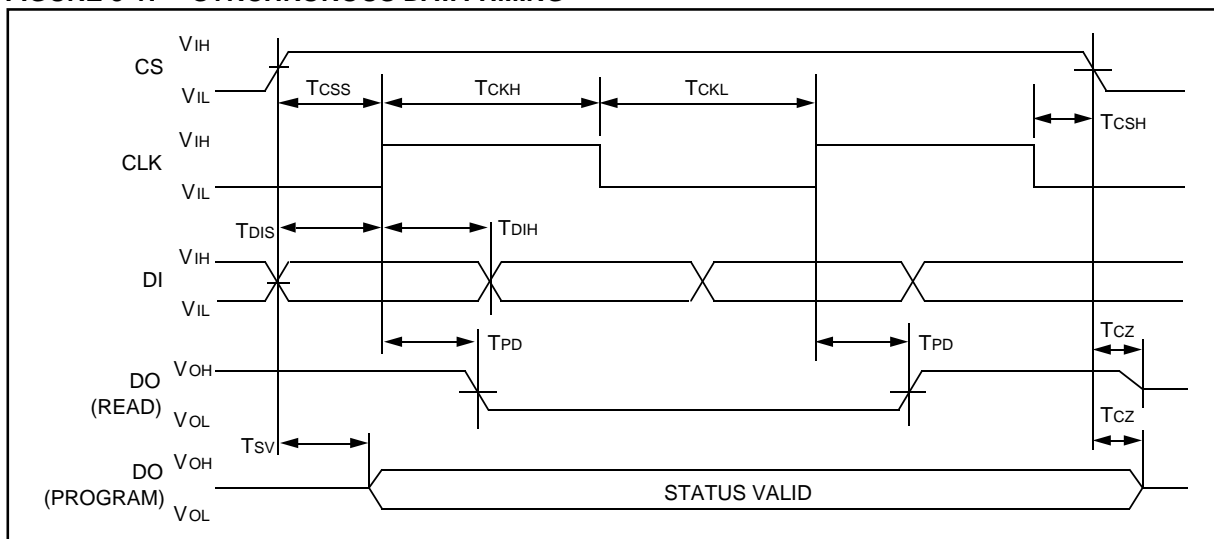

# 93LC46/56/66

## 3.4 ERASE

The ERASE instruction forces all data bits of the specified address to the logical "1" state. CS is brought low following the loading of the last address bit. This falling edge of the CS pin initiates the self-timed programming cycle.

The DO pin indicates the  $\text{READY}/\overline{\text{BUSY}}$  status of the device if CS is brought high after a minimum of 250 ns low ( $T_{\text{CSL}}$ ). DO at logical "0" indicates that programming is still in progress. DO at logical "1" indicates that the register at the specified address has been erased and the device is ready for another instruction.

The ERASE cycle takes 4 ms per word (Typical).

## 3.5 Erase All (ERAL)

The Erase All (ERAL) instruction will erase the entire memory array to the logical "1" state. The ERAL cycle is identical to the ERASE cycle except for the different opcode. The ERAL cycle is completely self-timed and commences at the falling edge of the CS. Clocking of the CLK pin is not necessary after the device has entered the self clocking mode. The ERAL instruction is guaranteed at  $V_{\text{CC}} = +4.5\text{V}$  to  $+6.0\text{V}$ .

The DO pin indicates the  $\text{READY}/\overline{\text{BUSY}}$  status of the device if CS is brought high after a minimum of 250 ns low ( $T_{\text{CSL}}$ ) and before the entire write cycle is complete.

The ERAL cycle takes 15 ms maximum (8 ms typical).

FIGURE 3-2: ERASE TIMING

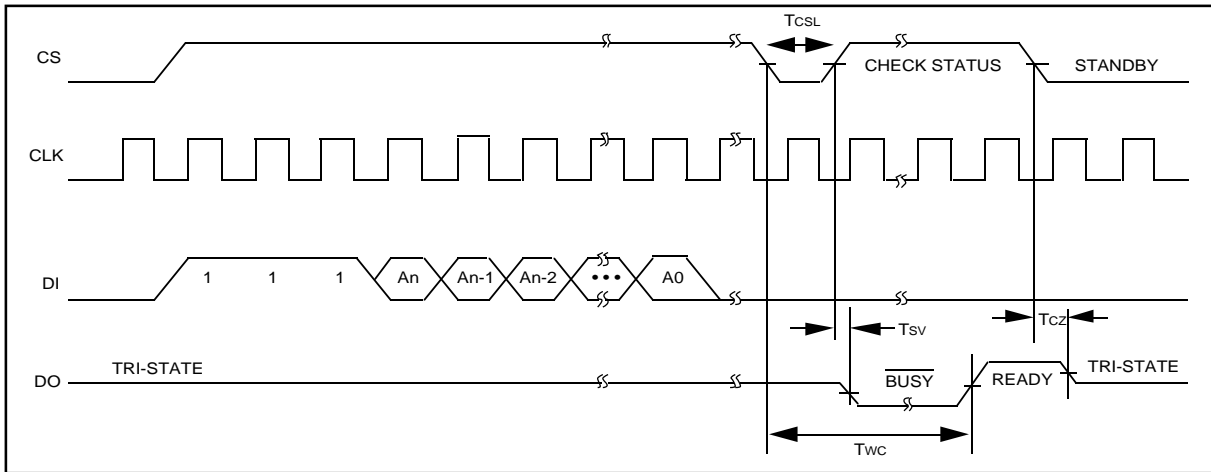
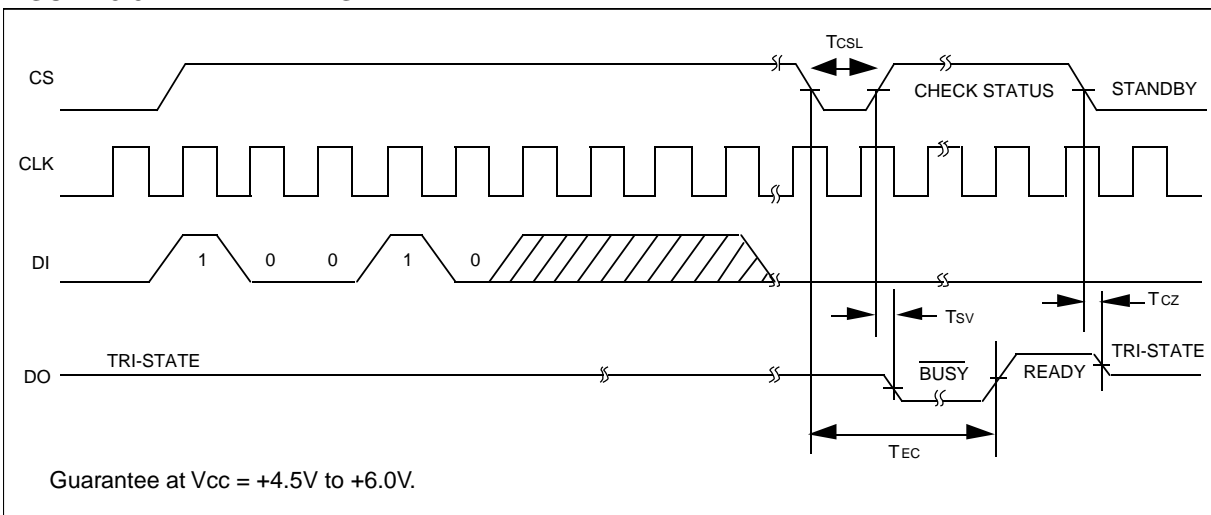

FIGURE 3-3: ERAL TIMING



### 3.6 ERASE/WRITE Disable and Enable (EWEN, EWDS)

The 93LC46/56/66 powers up in the ERASE/WRITE Disable (EWDS) state. All programming modes must be preceded by an ERASE/WRITE Enable (EWEN) instruction. Once the EWEN instruction is executed, programming remains enabled until an EWDS instruction is executed or VCC is removed from the device. To protect against accidental data disturb, the EWDS instruction can be used to disable all ERASE/WRITE functions and should follow all programming operations. Execution of a READ instruction is independent of both the EWDS and EWEN instructions.

### 3.7 READ

The READ instruction outputs the serial data of the addressed memory location on the DO pin. A dummy zero bit precedes the 8-bit (x8 organization) or 16-bit (x16 organization) output string. The output data bits will toggle on the rising edge of the CLK and are stable after the specified time delay (TPD.). Sequential read is possible when CS is held high. The memory data will automatically cycle to the next register and output sequentially.

**FIGURE 3-4: EWDS TIMING**

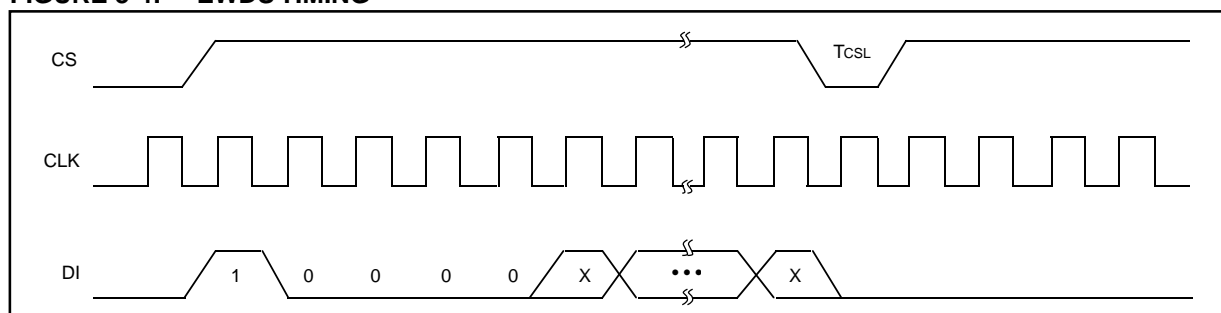

**FIGURE 3-5: EWEN TIMING**

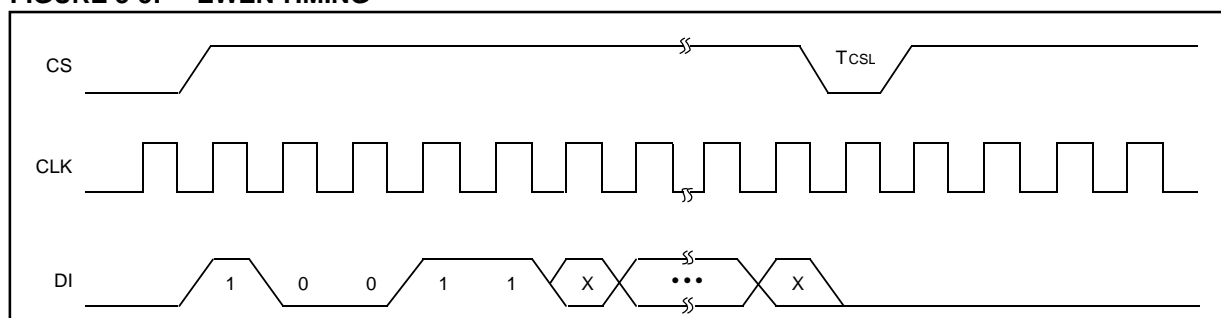

**FIGURE 3-6: READ TIMING**

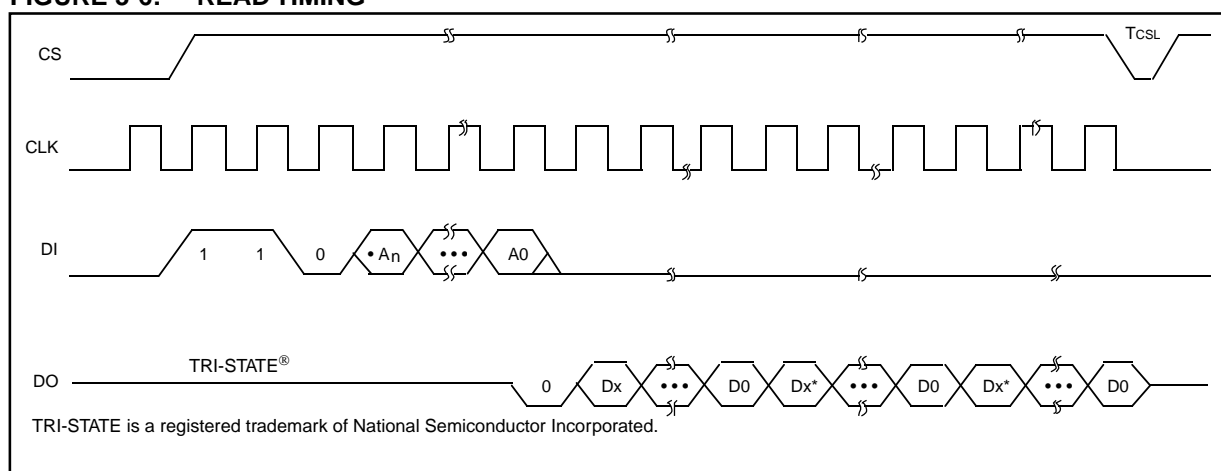

# 93LC46/56/66

## 3.8 WRITE

The WRITE instruction is followed by 8 bits (or by 16 bits) of data which are written into the specified address. After the last data bit is put on the DI pin, CS must be brought low before the next rising edge of the CLK clock. This falling edge of CS initiates the self-timed auto-erase and programming cycle.

The DO pin indicates the  $\text{READY}/\overline{\text{BUSY}}$  status of the device, if CS is brought high after a minimum of 250 ns low ( $T_{\text{CSL}}$ ) and before the entire write cycle is complete. DO at logical "0" indicates that programming is still in progress. DO at logical "1" indicates that the register at the specified address has been written with the data specified and the device is ready for another instruction.

The WRITE cycle takes 4 ms per word (Typical).

## 3.9 Write All (WRAL)

The Write All (WRAL) instruction will write the entire memory array with the data specified in the command. The WRAL cycle is completely self-timed and commences at the falling edge of the CS. Clocking of the CLK pin is not necessary after the device has entered the self clocking mode. The WRAL command does include an automatic ERAL cycle for the device. Therefore, the WRAL instruction does not require an ERAL instruction, but the chip must be in the EWEN status. The WRAL instruction is guaranteed at  $V_{\text{CC}} = +4.5\text{V}$  to  $+6.0\text{V}$ .

The DO pin indicates the  $\text{READY}/\overline{\text{BUSY}}$  status of the device if CS is brought high after a minimum of 250 ns low ( $T_{\text{CSL}}$ ).

The WRAL cycle takes 30 ms maximum (16 ms typical).

FIGURE 3-7: WRITE TIMING

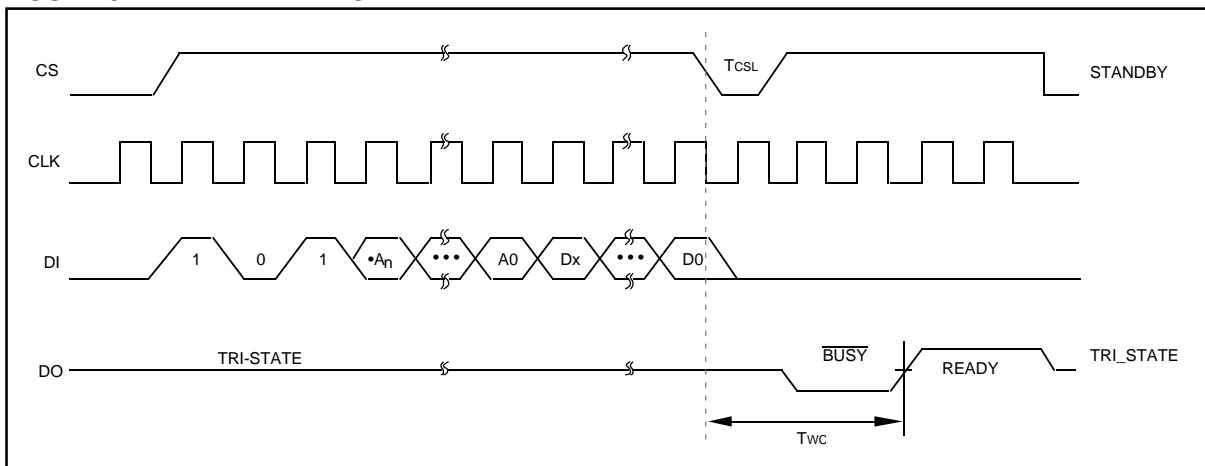
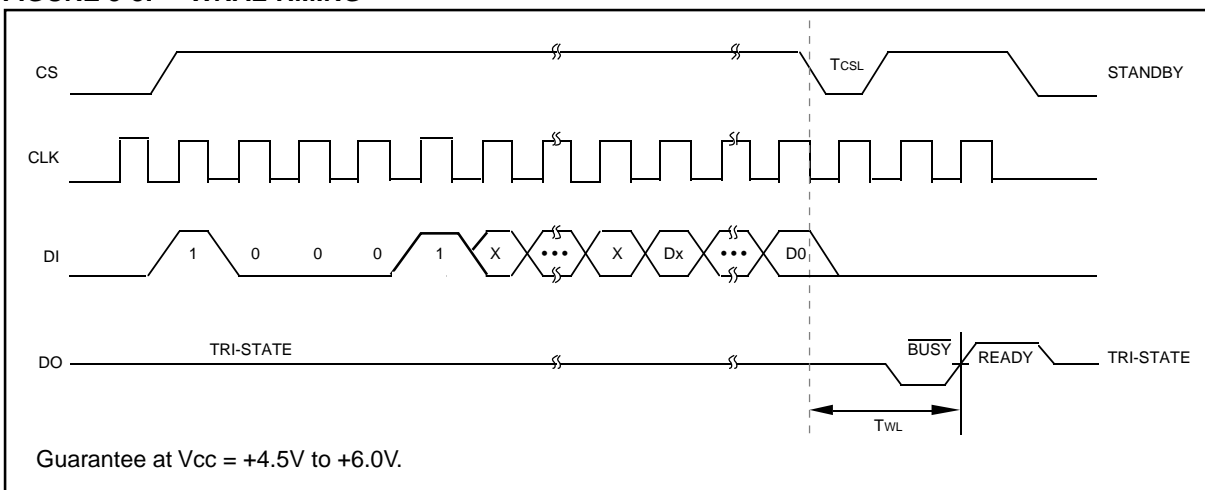

FIGURE 3-8: WRAL TIMING





NOTES:

# 93LC46/56/66

---

---

NOTES:

## 93LC46/56/66 PRODUCT IDENTIFICATION SYSTEM

To order or obtain information, e.g., on pricing or delivery, refer to the factory or the listed sales office..

93LC46/56/66	—	/P	<b>Package:</b>	P = Plastic DIP (300 mil Body), 8-lead
				SL = Plastic SOIC (107 mil Body), 14-lead
			<b>Temperature Range:</b>	SN = Plastic SOIC (150 mil Body), 8-lead
				SM = Plastic SOIC (207 mil Body), 8-lead
				Blank = 0°C to +70°C
				I = -40°C to +85°C
			<b>Device:</b>	93LC46 1K Microwire Serial EEPROM
				93LC46T 1K Microwire Serial EEPROM, Tape and Reel
				93LC46X 1K Microwire Serial EEPROM in alternate pinouts (SN package only)
				93LC46XT 1K Microwire Serial EEPROM in alternate pinouts, Tape and Reel (SN package only)
				93LC56 2K Microwire Serial EEPROM
				93LC56T 2K Microwire Serial EEPROM, Tape and Reel
				93LC56X 2K Microwire Serial EEPROM in alternate pinouts (SN package only)
				93LC56XT 2K Microwire Serial EEPROM in alternate pinouts, Tape and Reel (SN package only)
				93LC66 4K Microwire Serial EEPROM
				93LC66T 4K Microwire Serial EEPROM, Tape and Reel
				93LC66X 4K Microwire Serial EEPROM in alternate pinouts (SN package only)
				93LC66XT 4K Microwire Serial EEPROM in alternate pinouts, Tape and Reel (SN package only)

### Sales and Support

#### Data Sheets

Products supported by a preliminary Data Sheet may have an errata sheet describing minor operational differences and recommended workarounds. To determine if an errata sheet exists for a particular device, please contact one of the following:

1. Your local Microchip sales office
2. The Microchip Corporate Literature Center U.S. FAX: (602) 786-7277
3. The Microchip's Bulletin Board, via your local CompuServe number (CompuServe membership NOT required).

---

---

# WORLDWIDE SALES & SERVICE

---

---

## AMERICAS

### Corporate Office

Microchip Technology Inc.  
2355 West Chandler Blvd.  
Chandler, AZ 85224-6199  
Tel: 602-786-7200 Fax: 602-786-7277  
Technical Support: 602 786-7627  
Web: <http://www.microchip.com>

### Atlanta

Microchip Technology Inc.  
500 Sugar Mill Road, Suite 200B  
Atlanta, GA 30350  
Tel: 770-640-0034 Fax: 770-640-0307

### Boston

Microchip Technology Inc.  
5 Mount Royal Avenue  
Marlborough, MA 01752  
Tel: 508-480-9990 Fax: 508-480-8575

### Chicago

Microchip Technology Inc.  
333 Pierce Road, Suite 180  
Itasca, IL 60143  
Tel: 630-285-0071 Fax: 630-285-0075

### Dallas

Microchip Technology Inc.  
14651 Dallas Parkway, Suite 816  
Dallas, TX 75240-8809  
Tel: 972-991-7177 Fax: 972-991-8588

### Dayton

Microchip Technology Inc.  
Two Prestige Place, Suite 150  
Miamisburg, OH 45342  
Tel: 937-291-1654 Fax: 937-291-9175

### Los Angeles

Microchip Technology Inc.  
18201 Von Karman, Suite 1090  
Irvine, CA 92612  
Tel: 714-263-1888 Fax: 714-263-1338

### New York

Microchip Technology Inc.  
150 Motor Parkway, Suite 416  
Hauppauge, NY 11788  
Tel: 516-273-5305 Fax: 516-273-5335

### San Jose

Microchip Technology Inc.  
2107 North First Street, Suite 590  
San Jose, CA 95131  
Tel: 408-436-7950 Fax: 408-436-7955

### Toronto

Microchip Technology Inc.  
5925 Airport Road, Suite 200  
Mississauga, Ontario L4V 1W1, Canada  
Tel: 905-405-6279 Fax: 905-405-6253

## ASIA/PACIFIC

### Hong Kong

Microchip Asia Pacific  
RM 3801B, Tower Two  
Metroplaza  
223 Hing Fong Road  
Kwai Fong, N.T., Hong Kong  
Tel: 852-2-401-1200 Fax: 852-2-401-3431

### India

Microchip Technology India  
No. 6, Legacy, Convent Road  
Bangalore 560 025, India  
Tel: 91-80-229-0061 Fax: 91-80-229-0062

### Korea

Microchip Technology Korea  
168-1, Youngbo Bldg. 3 Floor  
Samsung-Dong, Kangnam-Ku  
Seoul, Korea  
Tel: 82-2-554-7200 Fax: 82-2-558-5934

### Shanghai

Microchip Technology  
RM 406 Shanghai Golden Bridge Bldg.  
2077 Yan'an Road West, Hongjiao District  
Shanghai, PRC 200335  
Tel: 86-21-6275-5700  
Fax: 86 21-6275-5060

### Singapore

Microchip Technology Taiwan  
Singapore Branch  
200 Middle Road  
#10-03 Prime Centre  
Singapore 188980  
Tel: 65-334-8870 Fax: 65-334-8850

### Taiwan, R.O.C

Microchip Technology Taiwan  
10F-1C 207  
Tung Hua North Road  
Taipei, Taiwan, ROC  
Tel: 886 2-717-7175 Fax: 886-2-545-0139

## EUROPE

### United Kingdom

Arizona Microchip Technology Ltd.  
Unit 6, The Courtyard  
Meadow Bank, Furlong Road  
Bourne End, Buckinghamshire SL8 5AJ  
Tel: 44-1628-851077 Fax: 44-1628-850259

### France

Arizona Microchip Technology SARL  
Zone Industrielle de la Bonde  
2 Rue du Buisson aux Fraises  
91300 Massy, France  
Tel: 33-1-69-53-63-20 Fax: 33-1-69-30-90-79

### Germany

Arizona Microchip Technology GmbH  
Gustav-Heinemann-Ring 125  
D-81739 München, Germany  
Tel: 49-89-627-144 0 Fax: 49-89-627-144-44

### Italy

Arizona Microchip Technology SRL  
Centro Direzionale Colleone  
Palazzo Taurus 1 V. Le Colleoni 1  
20041 Agrate Brianza  
Milan, Italy  
Tel: 39-39-6899939 Fax: 39-39-6899883

## JAPAN

Microchip Technology Intl. Inc.  
Benex S-1 6F  
3-18-20, Shin Yokohama  
Kohoku-Ku, Yokohama  
Kanagawa 222 Japan  
Tel: 81-4-5471- 6166 Fax: 81-4-5471-6122

5/8/97



**MICROCHIP**

All rights reserved. © 1997, Microchip Technology Incorporated, USA. 6/97

 Printed on recycled paper.

---

Information contained in this publication regarding device applications and the like is intended for suggestion only and may be superseded by updates. No representation or warranty is given and no liability is assumed by Microchip Technology Incorporated with respect to the accuracy or use of such information, or infringement of patents or other intellectual property rights arising from such use or otherwise. Use of Microchip's products as critical components in life support systems is not authorized except with express written approval by Microchip. No licenses are conveyed, implicitly or otherwise, under any intellectual property rights. The Microchip logo and name are registered trademarks of Microchip Technology Inc. in the U.S.A. and other countries. All rights reserved. All other trademarks mentioned herein are the property of their respective companies.

---