

THE PART CONFORMS TO STANDARD JEDEC PACKAGE SPECIFICATIONS WHICH CAN BE FOUND ON OUR WEBSITE (WWW.MICROCHIP.COM)



**MICROCHIP**

UNDER "DEVELOPERS TOOLBOX" → "PACKAGING SPECIFICATIONS"

→ "PACKAGING - COMMERCIAL/INDUSTRIAL...". THESE STANDARD PACKAGE FOOTPRINTS SHOULD BE SUPPORTED BY MOST CAD S/W.

## Packaging Diagrams and Parameters

16-Lead Plastic Small Outline (SL) – Narrow 150 mil (SOIC)

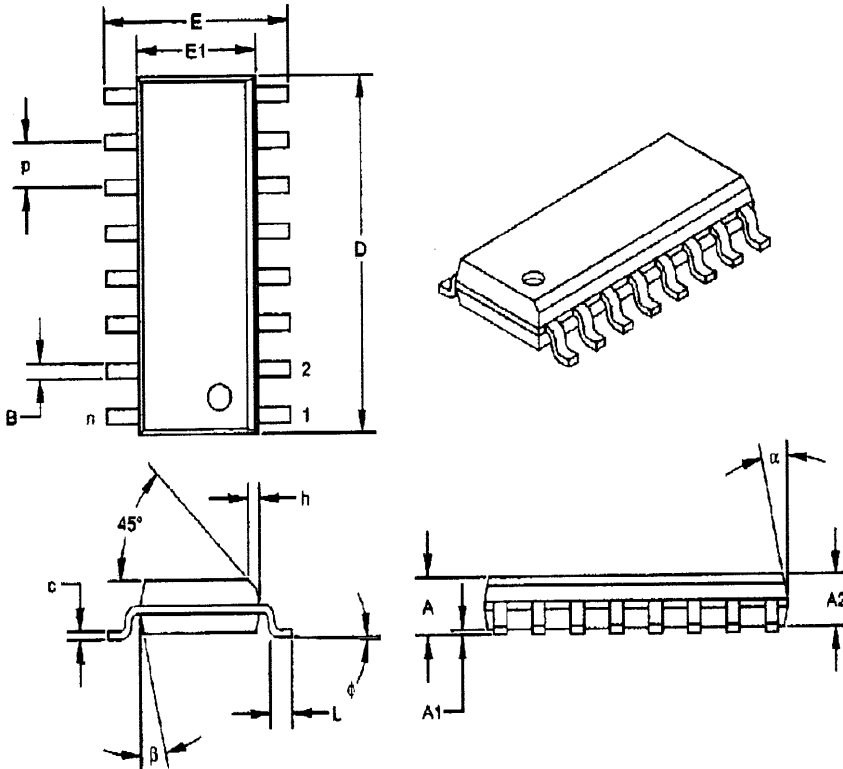

Dimension	Units	INCHES*			MILLIMETERS		
		MIN	NOM	MAX	MIN	NOM	MAX
Number of Pins	n		16			16	
Pitch	p		.050			1.27	
Overall Height	A	.053	.061	.069	1.35	1.55	1.75
Molded Package Thickness	A2	.052	.057	.061	1.32	1.44	1.55
Standoff §	A1	.004	.007	.010	0.10	0.18	0.25
Overall Width	E	.228	.237	.244	5.79	6.02	6.20
Molded Package Width	E1	.150	.154	.157	3.81	3.90	3.99
Overall Length	D	.386	.390	.394	9.80	9.91	10.01
Chamfer Distance	h	.010	.015	.020	0.25	0.38	0.51
Foot Length	L	.016	.033	.050	0.41	0.84	1.27
Foot Angle	φ	0	4	8	0	4	8
Lead Thickness	c	.008	.009	.010	0.20	0.23	0.25
Lead Width	B	.013	.017	.020	0.33	0.42	0.51
Mold Draft Angle Top	α	0	12	15	0	12	15
Mold Draft Angle Bottom	β	0	12	15	0	12	15

\* Controlling Parameter

§ Significant Characteristic

Notes:

Dimensions D and E1 do not include mold flash or protrusions. Mold flash or protrusions shall not exceed

.010" (0.254mm) per side.

JEDEC Equivalent: MS-012

Drawing No. C04-108



# MCP3204/3208

## 2.7V 4-Channel/8-Channel 12-Bit A/D Converters with SPI™

### FEATURES

- 12-bit resolution
- $\pm 1$  LSB max DNL
- $\pm 1$  LSB max INL (MCP3204/3208-B)
- $\pm 2$  LSB max INL (MCP3204/3208-C)
- 4 (MCP3204) or 8 (MCP3208) input channels
- Analog inputs programmable as single-ended or pseudo differential pairs
- On-chip sample and hold
- SPI™ serial interface (modes 0,0 and 1,1)
- Single supply operation: 2.7V - 5.5V
- 100ksps max. sampling rate at  $V_{DD} = 5V$
- 50ksps max. sampling rate at  $V_{DD} = 2.7V$
- Low power CMOS technology
  - 500 nA typical standby current, 2 $\mu$ A max.
  - 400  $\mu$ A max. active current at 5V
- Industrial temp range: -40°C to +85°C
- Available in PDIP, SOIC and TSSOP packages

### APPLICATIONS

- Sensor Interface
- Process Control
- Data Acquisition
- Battery Operated Systems

### DESCRIPTION

The Microchip Technology Inc. MCP3204/3208 devices are successive approximation 12-bit Analog-to-Digital (A/D) Converters with on-board sample and hold circuitry. The MCP3204 is programmable to provide two pseudo-differential input pairs or four single-ended inputs. The MCP3208 is programmable to provide four pseudo-differential input pairs or eight single-ended inputs. Differential Nonlinearity (DNL) is specified at  $\pm 1$  LSB, and Integral Nonlinearity (INL) is offered in  $\pm 1$  LSB (MCP3204/3208-B) and  $\pm 2$  LSB (MCP3204/3208-C) versions. Communication with the devices is done using a simple serial interface compatible with the SPI protocol. The devices are capable of conversion rates of up to 100ksps. The MCP3204/3208 devices operate over a broad voltage range (2.7V - 5.5V). Low current design permits operation with typical standby and active currents of only 500nA and 320 $\mu$ A, respectively. The MCP3204 is offered in 14-pin PDIP, 150mil SOIC and TSSOP packages, and the MCP3208 is offered in 16-pin PDIP and SOIC packages.

SPI is a trademark of Motorola Inc.

### PACKAGE TYPES

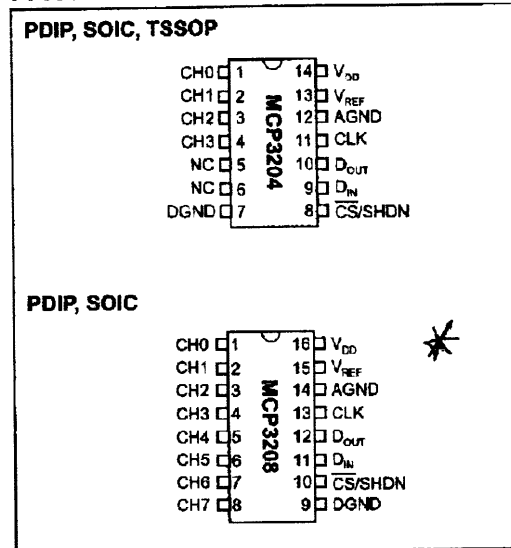

### FUNCTIONAL BLOCK DIAGRAM

