



**MICROCHIP**

# PIC16C63A/65B/73B/74B

## 28/40-Pin 8-Bit CMOS Microcontrollers

Device	Pins	A/D	PSP
PIC16C63A	28	NO	NO
PIC16C73B	28	YES	NO
PIC16C65B	40	NO	YES
PIC16C74B	40	YES	YES

### Microcontroller Core Features:

- High-performance RISC CPU
- Only 35 single word instructions to learn
- All single cycle instructions except for program branches which are two cycle
- Operating speed: DC - 20 MHz clock input  
DC - 200 ns instruction cycle
- 4K x 14 words of Program Memory,  
192 x 8 bytes of Data Memory (RAM)
- Interrupt capability (up to 12 internal/external interrupt sources)
- Eight level deep hardware stack
- Direct, indirect, and relative addressing modes
- Power-on Reset (POR)
- Power-up Timer (PWRT) and Oscillator Start-up Timer (OST)
- Watchdog Timer (WDT) with its own on-chip RC oscillator for reliable operation
- Programmable code-protection
- Power saving SLEEP mode
- Selectable oscillator options
- Low-power, high-speed CMOS EPROM technology
- Fully static design
- In-Circuit Serial Programming™ (ICSP)
- Wide operating voltage range: 2.5V to 5.5V
- High Sink/Source Current 25/25 mA
- Commercial, Industrial and Extended temperature ranges
- Low-power consumption:
  - < 2 mA @ 5V, 4 MHz
  - 22.5 µA typical @ 3V, 32 kHz
  - < 1 µA typical standby current

### Pin Diagram

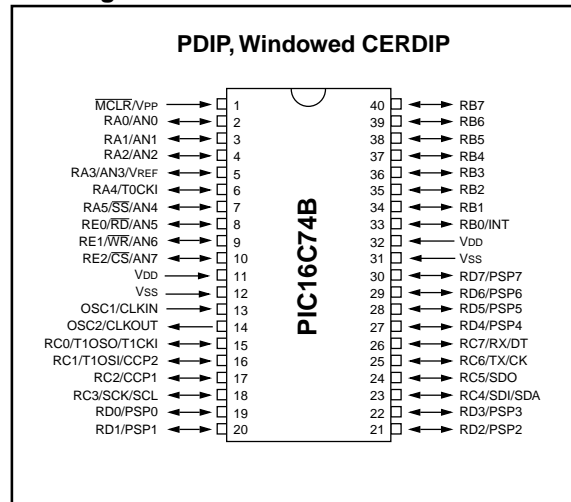

### Peripheral Features:

- Timer0: 8-bit timer/counter with 8-bit prescaler
- Timer1: 16-bit timer/counter with prescaler, can be incremented during sleep via external crystal/clock
- Timer2: 8-bit timer/counter with 8-bit period register, prescaler and postscaler
- Two Capture, Compare, PWM modules
- Capture is 16-bit, max. resolution is 12.5 ns, Compare is 16-bit, max. resolution is 200 ns, PWM maximum resolution is 10-bit
- 8-bit multi-channel Analog-to-Digital converter
- Synchronous Serial Port (SSP) with Enhanced SPI™ and I<sup>2</sup>C™
- Universal Synchronous Asynchronous Receiver Transmitter (USART/SCI)
- Parallel Slave Port (PSP) 8-bits wide, with external  $\overline{RD}$ ,  $\overline{WR}$  and  $\overline{CS}$  controls
- Brown-out detection circuitry for Brown-out Reset (BOR)

# PIC16C63A/65B/73B/74B

## Pin Diagrams

SDIP, SOIC, SSOP, Windowed CERDIP

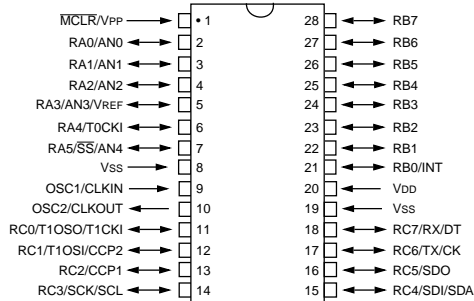

PIC16C73B

SDIP, SOIC, SSOP, Windowed CERDIP

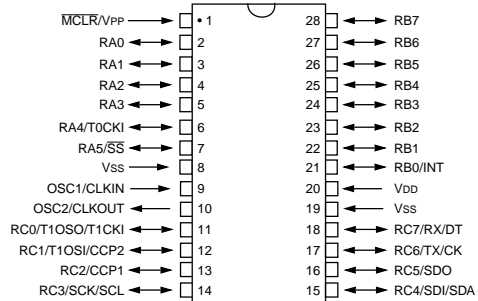

PIC16C63A

PDIP, Windowed CERDIP

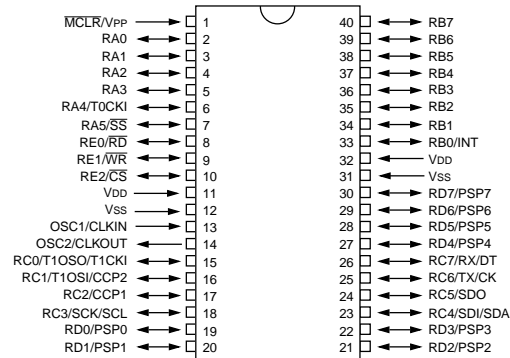

PIC16C65B

MQFP  
TQFP

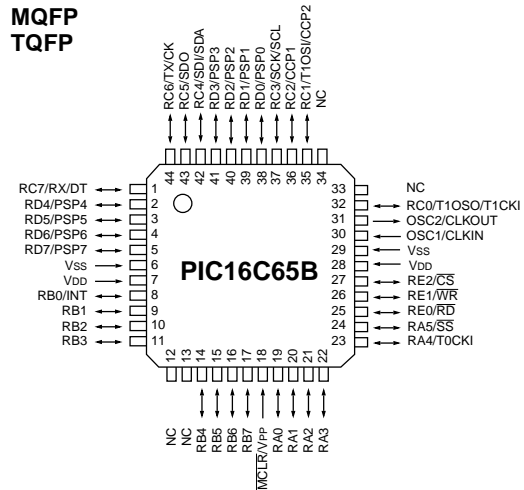

PIC16C65B

PLCC

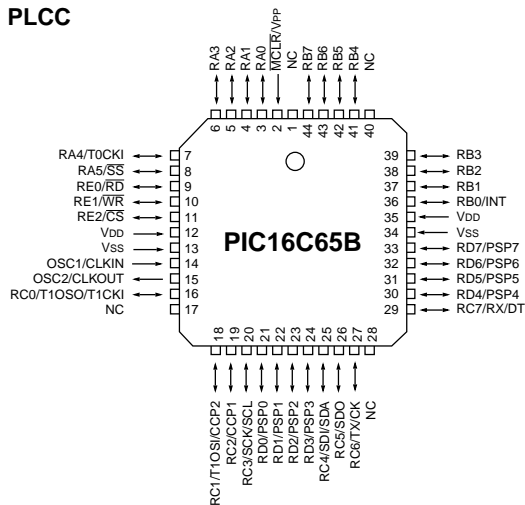

# PIC16C63A/65B/73B/74B

## Pin Diagrams (Cont'd)

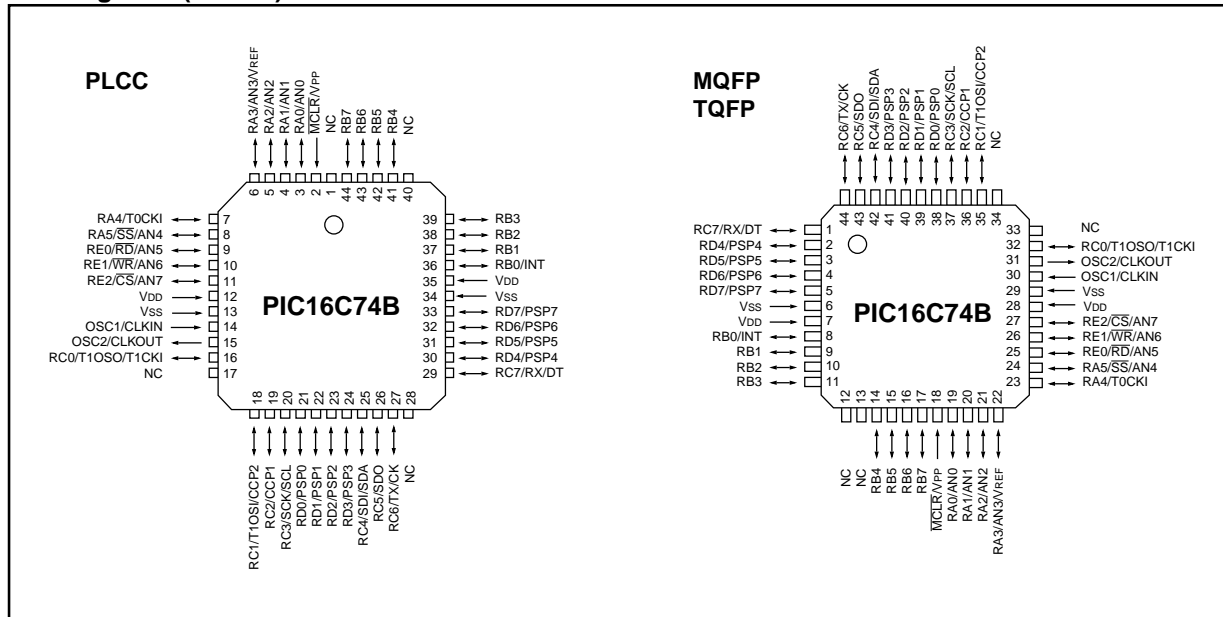

Key Features PICmicro™ Mid-Range Reference Manual (DS33023)	PIC16C63A	PIC16C65B	PIC16C73B	PIC16C74B
Operating Frequency	DC - 20 MHz	DC - 20 MHz	DC - 20 MHz	DC - 20 MHz
Resets (and Delays)	POR, BOR (PWRT, OST)	POR, BOR (PWRT, OST)	POR, BOR (PWRT, OST)	POR, BOR (PWRT, OST)
Program Memory (14-bit words)	4K	4K	4K	4K
Data Memory (bytes)	192	192	192	192
Interrupts	10	11	11	12
I/O Ports	Ports A,B,C	Ports A,B,C,D,E	Ports A,B,C	Ports A,B,C,D,E
Timers	3	3	3	3
Capture/Compare/PWM modules	2	2	2	2
Serial Communications	SSP, USART	SSP, USART	SSP, USART	SSP, USART
Parallel Communications	—	PSP	—	PSP
8-bit Analog-to-Digital Module	—	—	5 input channels	8 input channels
Instruction Set	35 Instructions	35 Instructions	35 Instructions	35 Instructions

# PIC16C63A/65B/73B/74B

## Table of Contents

1.0	Device Overview .....	5
2.0	Memory Organization.....	11
3.0	I/O Ports .....	25
4.0	Timer0 Module .....	37
5.0	Timer1 Module .....	39
6.0	Timer2 Module .....	43
7.0	Capture/Compare/PWM (CCP) Module(s).....	45
8.0	Synchronous Serial Port (SSP) Module .....	51
9.0	Universal Synchronous Asynchronous Receiver Transmitter (USART) .....	61
10.0	Analog-to-Digital Converter (A/D) Module.....	75
11.0	Special Features of the CPU.....	81
12.0	Instruction Set Summary.....	95
13.0	Development Support .....	97
14.0	Electrical Characteristics.....	101
15.0	DC and AC Characteristics Graphs and Tables.....	123
16.0	Packaging Information .....	125
Appendix A:	Revision History .....	137
Appendix B:	Device Differences .....	137
Appendix C:	Conversion Considerations .....	137
Appendix D:	Migration from Baseline to Midrange Devices.....	138
Appendix E:	Bit/Register Cross-Reference List .....	139
Index .....		141
On-Line Support.....		147
Reader Response .....		148
PIC16C63A/65B/73B/74B Product Identification System .....		149

## *To Our Valued Customers*

### **Most Current Data Sheet**

To obtain the most up-to-date version of this data sheet, please check our worldwide web site at:

<http://www.microchip.com>

You can determine the version of a data sheet by examining its literature number, found on the bottom outside corner of any page. The last character of the literature number is the version number. e.g., DS30000A is version A of document DS30000.

### **Errata**

An errata sheet may exist for current devices, describing minor operational differences (from the data sheet) and recommended workarounds. As device/documentation issues become known to us, we will publish an errata sheet. The errata will specify the revision of silicon and revision of document to which it applies.

To determine if an errata sheet exists for a particular device, please check with one of the following:

- Microchip's worldwide web site at <http://www.microchip.com>
- Your local Microchip sales office (see last page)
- The Microchip Corporate Literature Center; U.S. FAX: (602) 786-7277

When contacting a sales office or the literature center, please specify which device, revision of silicon and data sheet (include literature number) you are using.

### **Corrections to this Data Sheet**

We constantly strive to improve the quality of all our products and documentation. We have spent a great deal of time to ensure that this document is correct. However, we realize that we may have missed a few things. If you find any information that is missing or appears in error, please:

- Fill out and mail in the reader response form in the back of this data sheet, or
- E-mail us at [webmaster@microchip.com](mailto:webmaster@microchip.com).

We appreciate your assistance in making this a better document.

# PIC16C63A/65B/73B/74B

## 1.0 DEVICE OVERVIEW

This document contains device-specific information. Additional information may be found in the PICmicro™ Mid-Range Reference Manual (DS33023) which may be obtained from your local Microchip Sales Representative or downloaded from the Microchip web site. The Reference Manual should be considered a complementary document to this data sheet, and is highly recommended reading for a better understanding of the device architecture and operation of the peripheral modules.

There are four devices (PIC16C63A, PIC16C65B, PIC16C73B, PIC16C74B) covered by this data sheet. These devices come in 28- and 40-pin packages. The 28-pin devices do not have a Parallel Slave Port implemented. The PIC16C6X devices do not have the A/D module implemented.

The following two figures are device block diagrams sorted by pin number; 28-pin for Figure 1-1 and 40-pin for Figure 1-2. The 28-pin and 40-pin pinouts are listed in Table 1-1 and Table 1-2 respectively.

**FIGURE 1-1: PIC16C63A/PIC16C73B BLOCK DIAGRAM**

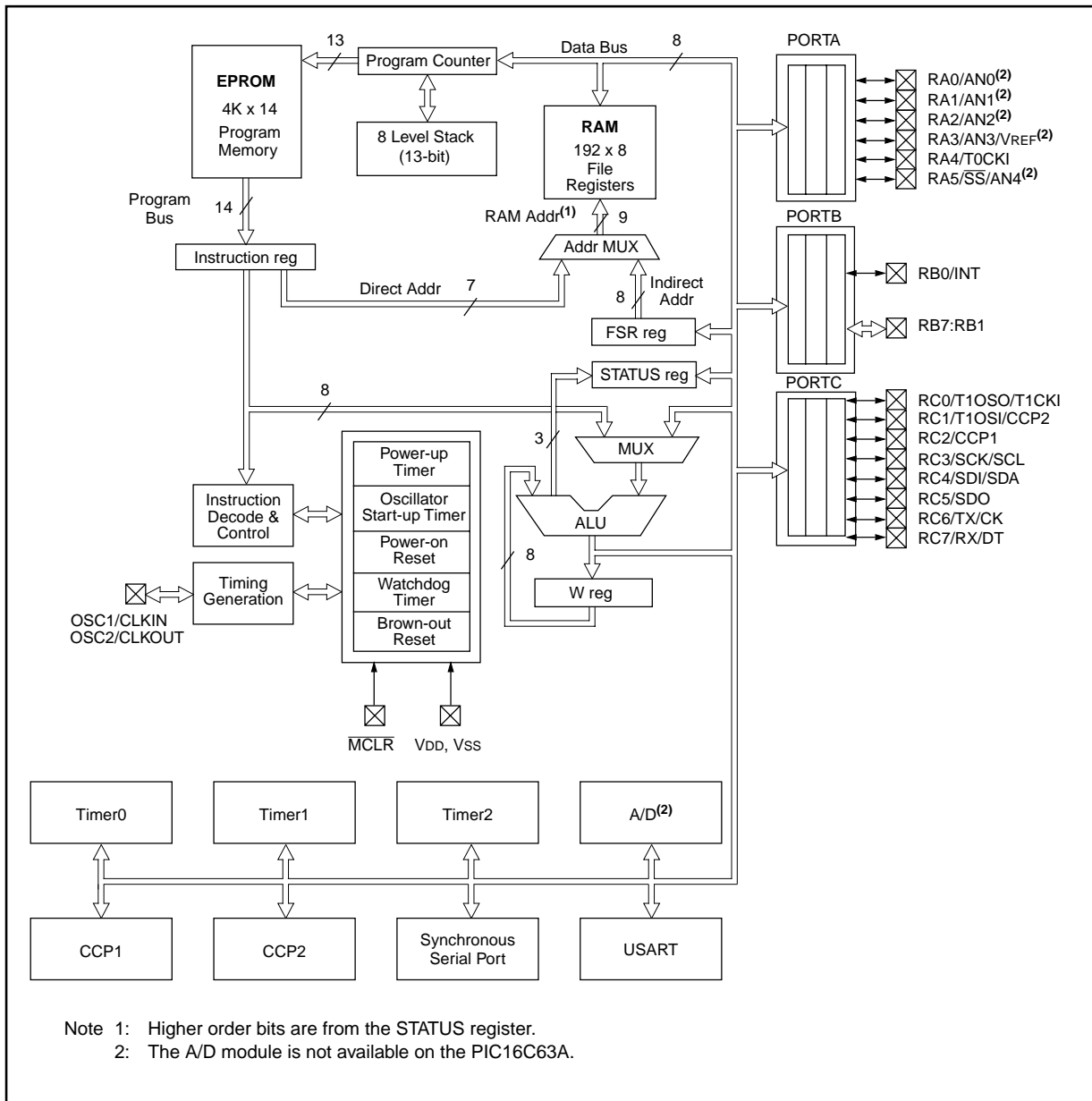

# PIC16C63A/65B/73B/74B

FIGURE 1-2: PIC16C65B/PIC16C74B BLOCK DIAGRAM

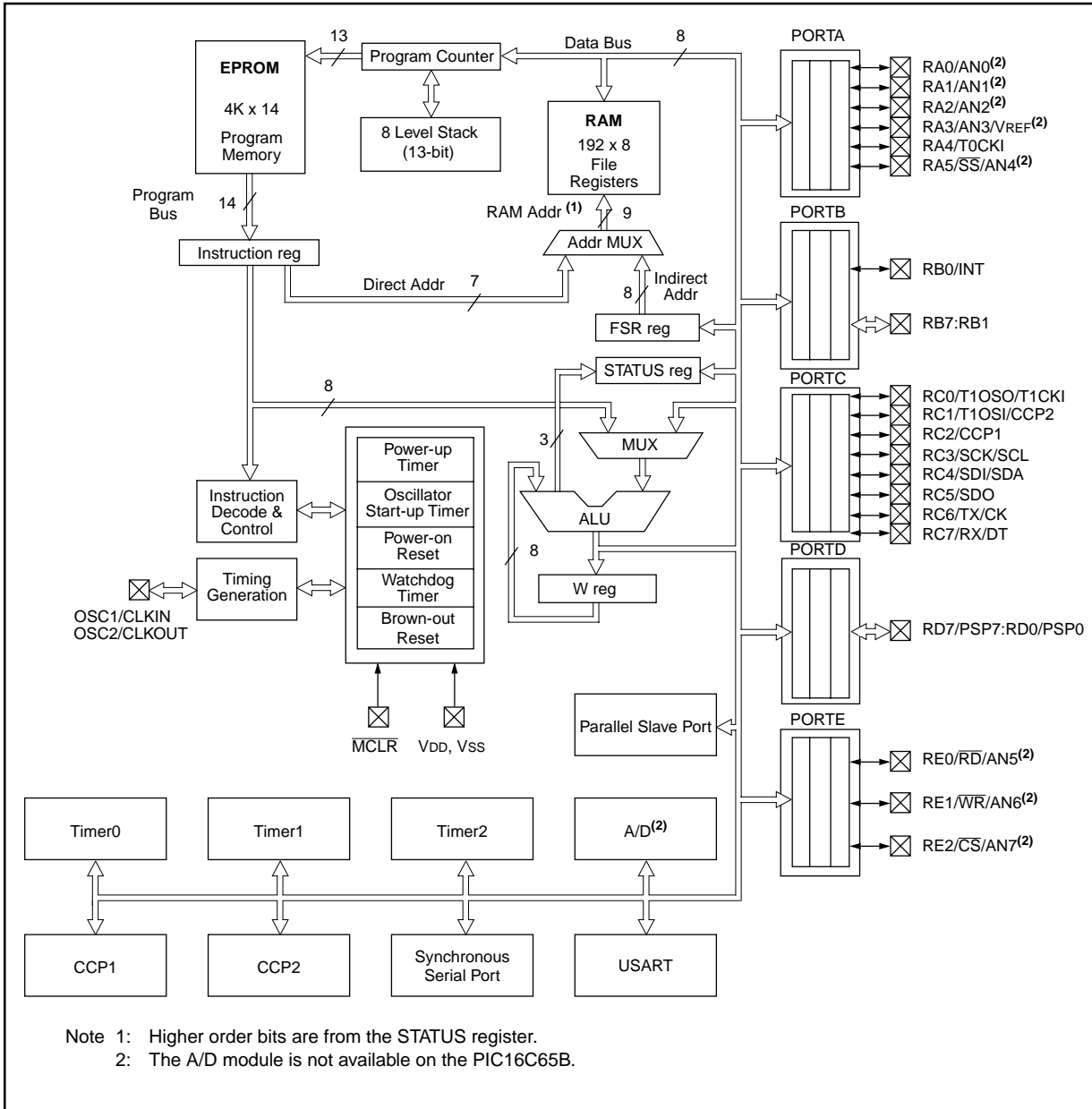

# PIC16C63A/65B/73B/74B

**TABLE 1-1: PIC16C63A/PIC16C73B PINOUT DESCRIPTION**

Pin Name	DIP Pin#	SOIC Pin#	I/O/P Type	Buffer Type	Description
OSC1/CLKIN	9	9	I	ST/CMOS <sup>(3)</sup>	Oscillator crystal input/external clock source input.
OSC2/CLKOUT	10	10	O	—	Oscillator crystal output. Connects to crystal or resonator in crystal oscillator mode. In RC mode, the OSC2 pin outputs CLKOUT which has 1/4 the frequency of OSC1, and denotes the instruction cycle rate.
MCLR/VPP	1	1	I/P	ST	Master clear (reset) input or programming voltage input. This pin is an active low reset to the device.
RA0/AN0 <sup>(4)</sup>	2	2	I/O	TTL	<p>PORTA is a bi-directional I/O port.</p> <p>RA0 can also be analog input0</p> <p>RA1 can also be analog input1</p> <p>RA2 can also be analog input2</p> <p>RA3 can also be analog input3 or analog reference voltage</p> <p>RA4 can also be the clock input to the Timer0 module. Output is open drain type.</p> <p>RA5 can also be analog input4 or the slave select for the synchronous serial port.</p>
RA1/AN1 <sup>(4)</sup>	3	3	I/O	TTL	
RA2/AN2 <sup>(4)</sup>	4	4	I/O	TTL	
RA3/AN3/VREF <sup>(4)</sup>	5	5	I/O	TTL	
RA4/T0CKI	6	6	I/O	ST	
RA5/SS/AN4 <sup>(4)</sup>	7	7	I/O	TTL	
RB0/INT	21	21	I/O	TTL/ST <sup>(1)</sup>	<p>PORTB is a bi-directional I/O port. PORTB can be software programmed for internal weak pull-up on all inputs.</p> <p>RB0 can also be the external interrupt pin.</p> <p>Interrupt on change pin.</p> <p>Interrupt on change pin.</p> <p>Interrupt on change pin. Serial programming clock.</p> <p>Interrupt on change pin. Serial programming data.</p>
RB1	22	22	I/O	TTL	
RB2	23	23	I/O	TTL	
RB3	24	24	I/O	TTL	
RB4	25	25	I/O	TTL	
RB5	26	26	I/O	TTL	
RB6	27	27	I/O	TTL/ST <sup>(2)</sup>	
RB7	28	28	I/O	TTL/ST <sup>(2)</sup>	
RC0/T1OSO/T1CKI	11	11	I/O	ST	<p>PORTC is a bi-directional I/O port.</p> <p>RC0 can also be the Timer1 oscillator output or Timer1 clock input.</p> <p>RC1 can also be the Timer1 oscillator input or Capture2 input/Compare2 output/PWM2 output.</p> <p>RC2 can also be the Capture1 input/Compare1 output/PWM1 output.</p> <p>RC3 can also be the synchronous serial clock input/output for both SPI and I<sup>2</sup>C modes.</p> <p>RC4 can also be the SPI Data In (SPI mode) or data I/O (I<sup>2</sup>C mode).</p> <p>RC5 can also be the SPI Data Out (SPI mode).</p> <p>RC6 can also be the USART Asynchronous Transmit or Synchronous Clock.</p> <p>RC7 can also be the USART Asynchronous Receive or Synchronous Data.</p>
RC1/T1OSI/CCP2	12	12	I/O	ST	
RC2/CCP1	13	13	I/O	ST	
RC3/SCK/SCL	14	14	I/O	ST	
RC4/SDI/SDA	15	15	I/O	ST	
RC5/SDO	16	16	I/O	ST	
RC6/TX/CK	17	17	I/O	ST	
RC7/RX/DT	18	18	I/O	ST	
VSS	8, 19	8, 19	P	—	Ground reference for logic and I/O pins.
VDD	20	20	P	—	Positive supply for logic and I/O pins.

Legend: I = input    O = output    I/O = input/output    P = power  
 — = Not used    TTL = TTL input    ST = Schmitt Trigger input

- Note 1: This buffer is a Schmitt Trigger input when configured as the external interrupt.  
 2: This buffer is a Schmitt Trigger input when used in serial programming mode.  
 3: This buffer is a Schmitt Trigger input when configured in RC oscillator mode and a CMOS input otherwise.  
 4: The A/D module is not available on the PIC16C63A.

# PIC16C63A/65B/73B/74B

**TABLE 1-2: PIC16C65B/PIC16C74B PINOUT DESCRIPTION**

Pin Name	DIP Pin#	PLCC Pin#	QFP Pin#	I/O/P Type	Buffer Type	Description
OSC1/CLKIN	13	14	30	I	ST/CMOS <sup>(4)</sup>	Oscillator crystal input/external clock source input.
OSC2/CLKOUT	14	15	31	O	—	Oscillator crystal output. Connects to crystal or resonator in crystal oscillator mode. In RC mode, OSC2 pin outputs CLKOUT which has 1/4 the frequency of OSC1, and denotes the instruction cycle rate.
MCLR/VPP	1	2	18	I/P	ST	Master clear (reset) input or programming voltage input. This pin is an active low reset to the device.
RA0/AN0 <sup>(5)</sup>	2	3	19	I/O	TTL	PORTA is a bi-directional I/O port. RA0 can also be analog input0 RA1 can also be analog input1 RA2 can also be analog input2 RA3 can also be analog input3 or analog reference voltage RA4 can also be the clock input to the Timer0 timer/counter. Output is open drain type. RA5 can also be analog input4 or the slave select for the synchronous serial port.
RA1/AN1 <sup>(5)</sup>	3	4	20	I/O	TTL	
RA2/AN2 <sup>(5)</sup>	4	5	21	I/O	TTL	
RA3/AN3/VREF <sup>(5)</sup>	5	6	22	I/O	TTL	
RA4/T0CKI	6	7	23	I/O	ST	
RA5/SS/AN4 <sup>(5)</sup>	7	8	24	I/O	TTL	
RB0/INT	33	36	8	I/O	TTL/ST <sup>(1)</sup>	PORTB is a bi-directional I/O port. PORTB can be software programmed for internal weak pull-up on all inputs. RB0 can also be the external interrupt pin.  Interrupt on change pin. Interrupt on change pin. Interrupt on change pin. Serial programming clock. Interrupt on change pin. Serial programming data.
RB1	34	37	9	I/O	TTL	
RB2	35	38	10	I/O	TTL	
RB3	36	39	11	I/O	TTL	
RB4	37	41	14	I/O	TTL	
RB5	38	42	15	I/O	TTL	
RB6	39	43	16	I/O	TTL/ST <sup>(2)</sup>	
RB7	40	44	17	I/O	TTL/ST <sup>(2)</sup>	

Legend: I = input    O = output    I/O = input/output    P = power  
 — = Not used    TTL = TTL input    ST = Schmitt Trigger input

- Note 1: This buffer is a Schmitt Trigger input when configured as an external interrupt.  
 2: This buffer is a Schmitt Trigger input when used in serial programming mode.  
 3: This buffer is a Schmitt Trigger input when configured as general purpose I/O and a TTL input when used in the Parallel Slave Port mode (for interfacing to a microprocessor bus).  
 4: This buffer is a Schmitt Trigger input when configured in RC oscillator mode and a CMOS input otherwise.  
 5: The A/D module is not available on the PIC16C65B.



# PIC16C63A/65B/73B/74B

**TABLE 1-2: PIC16C65B/PIC16C74B PINOUT DESCRIPTION (Cont'd)**

Pin Name	DIP Pin#	PLCC Pin#	QFP Pin#	I/O/P Type	Buffer Type	Description
RC0/T1OSO/T1CKI	15	16	32	I/O	ST	PORTC is a bi-directional I/O port. RC0 can also be the Timer1 oscillator output or a Timer1 clock input. RC1 can also be the Timer1 oscillator input or Capture2 input/Compare2 output/PWM2 output. RC2 can also be the Capture1 input/Compare1 output/PWM1 output. RC3 can also be the synchronous serial clock input/output for both SPI and I <sup>2</sup> C modes. RC4 can also be the SPI Data In (SPI mode) or data I/O (I <sup>2</sup> C mode). RC5 can also be the SPI Data Out (SPI mode). RC6 can also be the USART Asynchronous Transmit or Synchronous Clock. RC7 can also be the USART Asynchronous Receive or Synchronous Data.
RC1/T1OSI/CCP2	16	18	35	I/O	ST	
RC2/CCP1	17	19	36	I/O	ST	
RC3/SCK/SCL	18	20	37	I/O	ST	
RC4/SDI/SDA	23	25	42	I/O	ST	
RC5/SDO	24	26	43	I/O	ST	
RC6/TX/CK	25	27	44	I/O	ST	
RC7/RX/DT	26	29	1	I/O	ST	
RD0/PSP0	19	21	38	I/O	ST/TTL <sup>(3)</sup>	PORTD is a bi-directional I/O port or parallel slave port when interfacing to a microprocessor bus.
RD1/PSP1	20	22	39	I/O	ST/TTL <sup>(3)</sup>	
RD2/PSP2	21	23	40	I/O	ST/TTL <sup>(3)</sup>	
RD3/PSP3	22	24	41	I/O	ST/TTL <sup>(3)</sup>	
RD4/PSP4	27	30	2	I/O	ST/TTL <sup>(3)</sup>	
RD5/PSP5	28	31	3	I/O	ST/TTL <sup>(3)</sup>	
RD6/PSP6	29	32	4	I/O	ST/TTL <sup>(3)</sup>	
RD7/PSP7	30	33	5	I/O	ST/TTL <sup>(3)</sup>	
RE0/ $\overline{RD}$ /AN5 <sup>(5)</sup>	8	9	25	I/O	ST/TTL <sup>(3)</sup>	PORTE is a bi-directional I/O port. RE0 can also be read control for the parallel slave port, or analog input5. RE1 can also be write control for the parallel slave port, or analog input6. RE2 can also be select control for the parallel slave port, or analog input7.
RE1/ $\overline{WR}$ /AN6 <sup>(5)</sup>	9	10	26	I/O	ST/TTL <sup>(3)</sup>	
RE2/ $\overline{CS}$ /AN7 <sup>(5)</sup>	10	11	27	I/O	ST/TTL <sup>(3)</sup>	
VSS	12,31	13,34	6,29	P	—	Ground reference for logic and I/O pins.
VDD	11,32	12,35	7,28	P	—	Positive supply for logic and I/O pins.
NC	—	1,17,28,40	12,13,33,34		—	These pins are not internally connected. These pins should be left unconnected.

Legend: I = input    O = output    I/O = input/output    P = power  
 — = Not used    TTL = TTL input    ST = Schmitt Trigger input

- Note 1: This buffer is a Schmitt Trigger input when configured as an external interrupt.  
 2: This buffer is a Schmitt Trigger input when used in serial programming mode.  
 3: This buffer is a Schmitt Trigger input when configured as general purpose I/O and a TTL input when used in the Parallel Slave Port mode (for interfacing to a microprocessor bus).  
 4: This buffer is a Schmitt Trigger input when configured in RC oscillator mode and a CMOS input otherwise.  
 5: The A/D module is not available on the PIC16C65B.

# PIC16C63A/65B/73B/74B

---

NOTES:

# PIC16C63A/65B/73B/74B

## 2.0 MEMORY ORGANIZATION

There are two memory blocks in each of these PICmicro microcontrollers. Each block (Program Memory and Data Memory) has its own bus so that concurrent access can occur.

Additional information on device memory may be found in the PICmicro™ Mid-Range Reference Manual (DS33023).

### 2.1 Program Memory Organization

The PIC16C63A/65B/73B/74B microcontrollers have a 13-bit program counter capable of addressing an 8K x 14 program memory space. Each device has 4K x 14 words of program memory. Accessing a location above the physically implemented address will cause a wrap-around.

The reset vector is at 0000h and the interrupt vector is at 0004h.

**FIGURE 2-1: PROGRAM MEMORY MAP AND STACK**

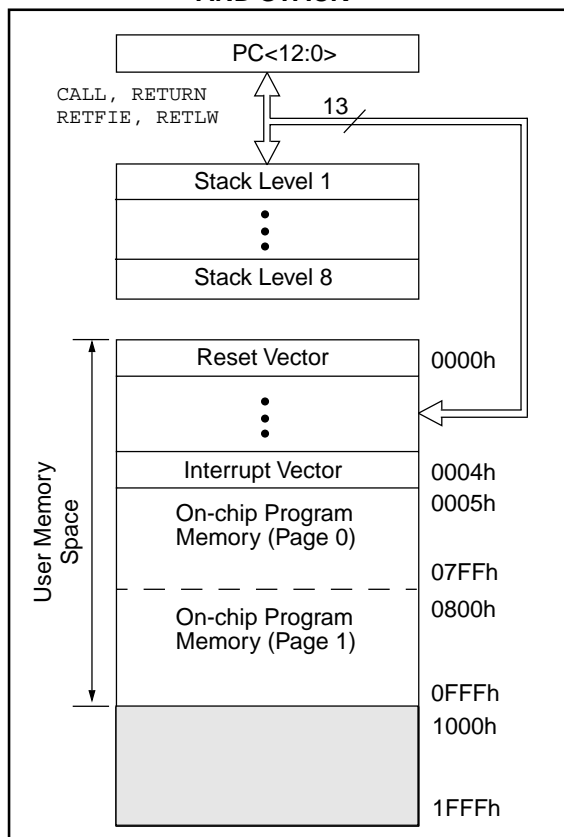

## 2.2 Data Memory Organization

The data memory is partitioned into multiple banks which contain the General Purpose Registers and the Special Function Registers. Bits RP1 and RP0 are the bank select bits.

RP1<sup>(1)</sup> RP0 (STATUS<6:5>)

- = 00 → Bank0
- = 01 → Bank1
- = 10 → Bank2 (not implemented)
- = 11 → Bank3 (not implemented)

Note 1: Maintain this bit clear to ensure upward compatibility with future products.

Each bank extends up to 7Fh (128 bytes). The lower locations of each bank are reserved for the Special Function Registers. Above the Special Function Registers are General Purpose Registers, implemented as static RAM. All implemented banks contain special function registers. Some "high use" special function registers from one bank may be mirrored in another bank for code reduction and quicker access.

### 2.2.1 GENERAL PURPOSE REGISTER FILE

The register file can be accessed either directly, or indirectly through the File Select Register FSR (Section 2.5).

# PIC16C63A/65B/73B/74B

**FIGURE 2-2: REGISTER FILE MAP**

File Address	File Address		File Address
00h	INDF <sup>(1)</sup>	INDF <sup>(1)</sup>	80h
01h	TMR0	OPTION_REG	81h
02h	PCL	PCL	82h
03h	STATUS	STATUS	83h
04h	FSR	FSR	84h
05h	PORTA	TRISA	85h
06h	PORTB	TRISB	86h
07h	PORTC	TRISC	87h
08h	PORTD <sup>(2)</sup>	TRISD <sup>(2)</sup>	88h
09h	PORTE <sup>(2)</sup>	TRISE <sup>(2)</sup>	89h
0Ah	PCLATH	PCLATH	8Ah
0Bh	INTCON	INTCON	8Bh
0Ch	PIR1	PIE1	8Ch
0Dh	PIR2	PIE2	8Dh
0Eh	TMR1L	PCON	8Eh
0Fh	TMR1H		8Fh
10h	T1CON		90h
11h	TMR2		91h
12h	T2CON	PR2	92h
13h	SSPBUF	SSPADD	93h
14h	SSPCON	SSPSTAT	94h
15h	CCPR1L		95h
16h	CCPR1H		96h
17h	CCP1CON		97h
18h	RCSTA	TXSTA	98h
19h	TXREG	SPBRG	99h
1Ah	RCREG		9Ah
1Bh	CCPR2L		9Bh
1Ch	CCPR2H		9Ch
1Dh	CCP2CON		9Dh
1Eh	ADRES <sup>(3)</sup>		9Eh
1Fh	ADCON0 <sup>(3)</sup>	ADCON1 <sup>(3)</sup>	9Fh
20h			A0h
	General Purpose Register	General Purpose Register	
7Fh			FFh
	Bank 0	Bank 1	

Unimplemented data memory locations, read as '0'.

Note 1: Not a physical register.  
 Note 2: These registers are not implemented on the PIC16C63A/73B, read as '0'.  
 Note 3: These registers are not implemented on the PIC16C63A/65B, read as '0'.

## 2.2.2 SPECIAL FUNCTION REGISTERS

The Special Function Registers are registers used by the CPU and Peripheral Modules for controlling the desired operation of the device. These registers are implemented as static RAM. A list of these registers is given in Table 2-1.

The special function registers can be classified into two sets; core (CPU) and peripheral. Those registers associated with the core functions are described in detail in this section. Those related to the operation of the peripheral features are described in detail in that peripheral feature section.

# PIC16C63A/65B/73B/74B

**TABLE 2-1 SPECIAL FUNCTION REGISTER SUMMARY**

Addr	Name	Bit 7	Bit 6	Bit 5	Bit 4	Bit 3	Bit 2	Bit 1	Bit 0	Value on POR, BOR	Value on all other resets (5)
<b>Bank 0</b>											
00h	INDF <sup>(1)</sup>	Addressing this location uses contents of FSR to address data memory (not a physical register)								0000 0000	0000 0000
01h	TMR0	Timer0 module's register								xxxx xxxx	uuuu uuuu
02h	PCL <sup>(1)</sup>	Program Counter's (PC) Least Significant Byte								0000 0000	0000 0000
03h	STATUS <sup>(1)</sup>	IRP <sup>(6)</sup>	RP1 <sup>(6)</sup>	RP0	T0	PD	Z	DC	C	rr01 lxxx	rr0q quuu
04h	FSR <sup>(1)</sup>	Indirect data memory address pointer								xxxx xxxx	uuuu uuuu
05h	PORTA <sup>(7)</sup>	—	—	PORTA Data Latch when written: PORTA pins when read						--0x 0000	--0u 0000
06h	PORTB <sup>(8)</sup>	PORTB Data Latch when written: PORTB pins when read								xxxx xxxx	uuuu uuuu
07h	PORTC <sup>(8)</sup>	PORTC Data Latch when written: PORTC pins when read								xxxx xxxx	uuuu uuuu
08h	PORTD <sup>(3,8)</sup>	PORTD Data Latch when written: PORTD pins when read								xxxx xxxx	uuuu uuuu
09h	PORTE <sup>(3,8)</sup>	—	—	—	—	—	RE2	RE1	RE0	---- -xxx	---- -uuu
0Ah	PCLATH <sup>(1,2)</sup>	—	—	—	Write Buffer for the upper 5 bits of the Program Counter					---0 0000	---0 0000
0Bh	INTCON <sup>(1)</sup>	GIE	PEIE	T0IE	INTE	RBIE	T0IF	INTF	RBIF	0000 000x	0000 000u
0Ch	PIR1	PSPIF <sup>(3)</sup>	ADIF <sup>(4)</sup>	RCIF	TXIF	SSPIF	CCP1IF	TMR2IF	TMR1IF	0000 0000	0000 0000
0Dh	PIR2	—	—	—	—	—	—	—	CCP2IF	---- -0	---- -0
0Eh	TMR1L	Holding register for the Least Significant Byte of the 16-bit TMR1 register								xxxx xxxx	uuuu uuuu
0Fh	TMR1H	Holding register for the Most Significant Byte of the 16-bit TMR1 register								xxxx xxxx	uuuu uuuu
10h	T1CON	—	—	T1CKPS1	T1CKPS0	T1OSCEN	T1SYNC	TMR1CS	TMR1ON	--00 0000	--uu uuuu
11h	TMR2	Timer2 module's register								0000 0000	0000 0000
12h	T2CON	—	TOUTPS3	TOUTPS2	TOUTPS1	TOUTPS0	TMR2ON	T2CKPS1	T2CKPS0	-000 0000	-000 0000
13h	SSPBUF	Synchronous Serial Port Receive Buffer/Transmit Register								xxxx xxxx	uuuu uuuu
14h	SSPCON	WCOL	SSPOV	SSPEN	CKP	SSPM3	SSPM2	SSPM1	SSPM0	0000 0000	0000 0000
15h	CCPR1L	Capture/Compare/PWM Register1 (LSB)								xxxx xxxx	uuuu uuuu
16h	CCPR1H	Capture/Compare/PWM Register1 (MSB)								xxxx xxxx	uuuu uuuu
17h	CCP1CON	—	—	CCP1X	CCP1Y	CCP1M3	CCP1M2	CCP1M1	CCP1M0	--00 0000	--00 0000
18h	RCSTA	SPEN	RX9	SREN	CREN	—	FERR	OERR	RX9D	0000 -00x	0000 -00x
19h	TXREG	USART Transmit Data Register								0000 0000	0000 0000
1Ah	RCREG	USART Receive Data Register								0000 0000	0000 0000
1Bh	CCPR2L	Capture/Compare/PWM Register2 (LSB)								xxxx xxxx	uuuu uuuu
1Ch	CCPR2H	Capture/Compare/PWM Register2 (MSB)								xxxx xxxx	uuuu uuuu
1Dh	CCP2CON	—	—	CCP2X	CCP2Y	CCP2M3	CCP2M2	CCP2M1	CCP2M0	--00 0000	--00 0000
1Eh	ADRES <sup>(4)</sup>	A/D Result Register								xxxx xxxx	uuuu uuuu
1Fh	ADCON0 <sup>(4)</sup>	ADCS1	ADCS0	CHS2	CHS1	CHS0	GO/DONE	—	ADON	0000 00-0	0000 00-0

Legend: x = unknown, u = unchanged, q = value depends on condition, - = unimplemented, read as '0', Shaded locations are unimplemented, read as '0'.

- Note 1: These registers can be addressed from either bank.  
 2: The upper byte of the program counter is not directly accessible. PCLATH is a holding register for PC<12:8> whose contents are transferred to the upper byte of the program counter.  
 3: PORTD and PORTE are not implemented on the PIC16C63A/73B, maintain as '0'.  
 4: A/D not implemented on the PIC16C63A/65B, maintain as '0'.  
 5: Other (non power-up) resets include: external reset through MCLR and the Watchdog Timer Reset.  
 6: The IRP and RP1 bits are reserved. Always maintain these bits clear.  
 7: On any device reset, these pins are configured as inputs.  
 8: This is the value that will be in the port output latch.

# PIC16C63A/65B/73B/74B

**TABLE 2-1 SPECIAL FUNCTION REGISTER SUMMARY (Cont'd)**

Addr	Name	Bit 7	Bit 6	Bit 5	Bit 4	Bit 3	Bit 2	Bit 1	Bit 0	Value on POR, BOR	Value on all other resets (5)
<b>Bank 1</b>											
80h	INDF <sup>(1)</sup>	Addressing this location uses contents of FSR to address data memory (not a physical register)								0000 0000	0000 0000
81h	OPTION_REG	RBP $\bar{U}$	INTEDG	T0CS	T0SE	PSA	PS2	PS1	PS0	1111 1111	1111 1111
82h	PCL <sup>(1)</sup>	Program Counter's (PC) Least Significant Byte								0000 0000	0000 0000
83h	STATUS <sup>(1)</sup>	IRP <sup>(6)</sup>	RP1 <sup>(6)</sup>	RP0	T $\bar{O}$	P $\bar{D}$	Z	DC	C	rr01 lxxx	rr0q quuu
84h	FSR <sup>(1)</sup>	Indirect data memory address pointer								xxxx xxxx	uuuu uuuu
85h	TRISA	—	—	PORTA Data Direction Register						--11 1111	--11 1111
86h	TRISB	PORTB Data Direction Register								1111 1111	1111 1111
87h	TRISC	PORTC Data Direction Register								1111 1111	1111 1111
88h	TRISD <sup>(3)</sup>	PORTD Data Direction Register								1111 1111	1111 1111
89h	TRISE <sup>(3)</sup>	IBF	OBF	IBOV	PSPMODE	—	PORTE Data Direction Bits			0000 -111	0000 -111
8Ah	PCLATH <sup>(1,2)</sup>	—	—	—	Write Buffer for the upper 5 bits of the Program Counter					---0 0000	---0 0000
8Bh	INTCON <sup>(1)</sup>	GIE	PEIE	T0IE	INTE	RBIE	T0IF	INTF	RBIF	0000 000x	0000 000u
8Ch	PIE1	PSPIE <sup>(3)</sup>	ADIE <sup>(4)</sup>	RCIE	TXIE	SSPIE	CCP1IE	TMR2IE	TMR1IE	0000 0000	0000 0000
8Dh	PIE2	—	—	—	—	—	—	—	CCP2IE	---- -0	---- -0
8Eh	PCON	—	—	—	—	—	—	POR	BOR	---- -qp	---- -uu
8Fh	—	Unimplemented								—	—
90h	—	Unimplemented								—	—
91h	—	Unimplemented								—	—
92h	PR2	Timer2 Period Register								1111 1111	1111 1111
93h	SSPADD	Synchronous Serial Port (I <sup>2</sup> C mode) Address Register								0000 0000	0000 0000
94h	SSPSTAT	SMP	CKE	D/ $\bar{A}$	P	S	R/ $\bar{W}$	UA	BF	0000 0000	0000 0000
95h	—	Unimplemented								—	—
96h	—	Unimplemented								—	—
97h	—	Unimplemented								—	—
98h	TXSTA	CSRC	TX9	TXEN	SYNC	—	BRGH	TRMT	TX9D	0000 -010	0000 -010
99h	SPBRG	Baud Rate Generator Register								0000 0000	0000 0000
9Ah	—	Unimplemented								—	—
9Bh	—	Unimplemented								—	—
9Ch	—	Unimplemented								—	—
9Dh	—	Unimplemented								—	—
9Eh	—	Unimplemented								—	—
9Fh	ADCON1 <sup>(4)</sup>	—	—	—	—	—	PCFG2	PCFG1	PCFG0	---- -000	---- -000

Legend: x = unknown, u = unchanged,  $\bar{c}$  = value depends on condition, - = unimplemented, read as '0', Shaded locations are unimplemented, read as '0'.

Note 1: These registers can be addressed from either bank.

2: The upper byte of the program counter is not directly accessible. PCLATH is a holding register for PC<12:8> whose contents are transferred to the upper byte of the program counter.

3: PORTD and PORTE are not implemented on the PIC16C63A/73B, maintain as '0'.

4: A/D not implemented on the PIC16C63A/65B, maintain as '0'.

5: Other (non power-up) resets include: external reset through  $\overline{MCLR}$  and the Watchdog Timer Reset.

6: The IRP and RP1 bits are reserved. Always maintain these bits clear.

7: On any device reset, these pins are configured as inputs.

8: This is the value that will be in the port output latch.

# PIC16C63A/65B/73B/74B

## 2.2.2.1 STATUS REGISTER

The STATUS register, shown in Figure 2-3, contains the arithmetic status of the ALU, the RESET status and the bank select bits for data memory.

The STATUS register can be the destination for any instruction, as with any other register. If the STATUS register is the destination for an instruction that affects the Z, DC or C bits, then the write to these three bits is disabled. These bits are set or cleared according to the device logic. Furthermore, the  $\overline{TO}$  and  $\overline{PD}$  bits are not writable. Therefore, the result of an instruction with the STATUS register as destination may be different than intended.

For example, `CLRF STATUS` will clear the upper-three bits and set the Z bit. This leaves the STATUS register as 000u u1uu (where u = unchanged).

It is recommended, therefore, that only `BCF`, `BSF`, `SWAPF` and `MOVWF` instructions are used to alter the STATUS register because these instructions do not affect the Z, C or DC bits from the STATUS register. For other instructions, not affecting any status bits, see the "Instruction Set Summary."

**Note 1:** These devices do not use bits IRP and RP1 (STATUS<7:6>). Maintain these bits clear to ensure upward compatibility with future products.

**Note 2:** The C and DC bits operate as a borrow and digit borrow bit, respectively, in subtraction. See the `SUBLW` and `SUBWF` instructions for examples.

**FIGURE 2-3: STATUS REGISTER (ADDRESS 03h, 83h)**

R/W-0	R/W-0	R/W-0	R-1	R-1	R/W-x	R/W-x	R/W-x
IRP	RP1	RP0	$\overline{TO}$	$\overline{PD}$	Z	DC	C
					bit0		
bit7							
<p>bit 7: <b>IRP:</b> Register Bank Select bit (used for indirect addressing)            1 = Bank 2, 3 (100h - 1FFh) - not implemented, maintain clear            0 = Bank 0, 1 (00h - FFh) - not implemented, maintain clear</p> <p>bit 6-5: <b>RP1:RP0:</b> Register Bank Select bits (used for direct addressing)            11 = Bank 3 (180h - 1FFh) - not implemented, maintain clear            10 = Bank 2 (100h - 17Fh) - not implemented, maintain clear            01 = Bank 1 (80h - FFh)            00 = Bank 0 (00h - 7Fh)            Each bank is 128 bytes</p> <p>bit 4: <b><math>\overline{TO}</math>:</b> Time-out bit            1 = After power-up, <code>CLRWDT</code> instruction, or <code>SLEEP</code> instruction            0 = A WDT time-out occurred</p> <p>bit 3: <b><math>\overline{PD}</math>:</b> Power-down bit            1 = After power-up or by the <code>CLRWDT</code> instruction            0 = By execution of the <code>SLEEP</code> instruction</p> <p>bit 2: <b>Z:</b> Zero bit            1 = The result of an arithmetic or logic operation is zero            0 = The result of an arithmetic or logic operation is not zero</p> <p>bit 1: <b>DC:</b> Digit carry/borrow bit (<code>ADDWF</code>, <code>ADDLW</code>, <code>SUBLW</code>, <code>SUBWF</code> instructions) (for borrow the polarity is reversed)            1 = A carry-out from the 4th low order bit of the result occurred            0 = No carry-out from the 4th low order bit of the result</p> <p>bit 0: <b>C:</b> Carry/borrow bit (<code>ADDWF</code>, <code>ADDLW</code>, <code>SUBLW</code>, <code>SUBWF</code> instructions)            1 = A carry-out from the most significant bit of the result occurred            0 = No carry-out from the most significant bit of the result occurred            Note: For borrow the polarity is reversed. A subtraction is executed by adding the two's complement of the second operand. For rotate (<code>RRF</code>, <code>RLF</code>) instructions, this bit is loaded with either the high or low order bit of the source register.</p>							

R = Readable bit  
 W = Writable bit  
 U = Unimplemented bit, read as '0'  
 - n = Value at POR reset

# PIC16C63A/65B/73B/74B

## 2.2.2.2 OPTION\_REG REGISTER

The OPTION\_REG register is a readable and writable register which contains various control bits to configure the TMR0 prescaler/WDT postscaler (single assignable register known also as the prescaler), the External INT Interrupt, TMR0, and the weak pull-ups on PORTB.

**Note:** To achieve a 1:1 prescaler assignment for the TMR0 register, assign the prescaler to the Watchdog Timer.

**FIGURE 2-4: OPTION\_REG REGISTER (ADDRESS 81h)**

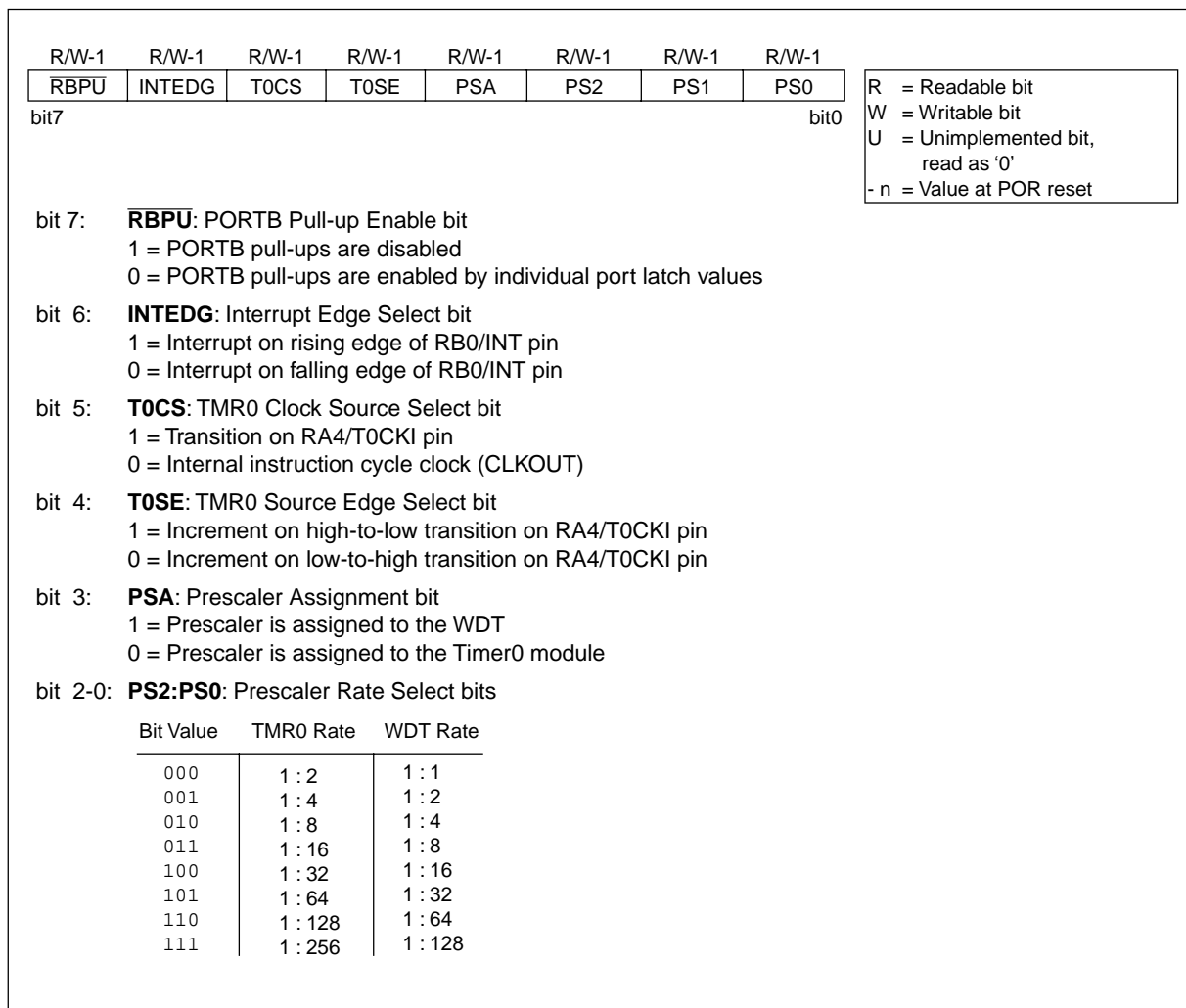



# PIC16C63A/65B/73B/74B

## 2.2.2.3 INTCON REGISTER

The INTCON Register is a readable and writable register which contains various enable and flag bits for the TMR0 register overflow, RB Port change and External RB0/INT pin interrupts.

**Note:** Interrupt flag bits get set when an interrupt condition occurs regardless of the state of its corresponding enable bit or the global enable bit, GIE (INTCON<7>). User software should ensure the appropriate interrupt flag bits are clear prior to enabling an interrupt.

**FIGURE 2-5: INTCON REGISTER (ADDRESS 0Bh, 8Bh)**

R/W-0	R/W-0	R/W-0	R/W-0	R/W-0	R/W-0	R/W-0	R/W-x
GIE	PEIE	TOIE	INTE	RBIE	TOIF	INTF	RBIF
bit7							bit0

R = Readable bit  
W = Writable bit  
U = Unimplemented bit, read as '0'  
- n = Value at POR reset

bit 7: **GIE:** Global Interrupt Enable bit  
1 = Enables all un-masked interrupts  
0 = Disables all interrupts

bit 6: **PEIE:** Peripheral Interrupt Enable bit  
1 = Enables all un-masked peripheral interrupts  
0 = Disables all peripheral interrupts

bit 5: **TOIE:** TMR0 Overflow Interrupt Enable bit  
1 = Enables the TMR0 interrupt  
0 = Disables the TMR0 interrupt

bit 4: **IINTE:** RB0/INT External Interrupt Enable bit  
1 = Enables the RB0/INT external interrupt  
0 = Disables the RB0/INT external interrupt

bit 3: **RBIE:** RB Port Change Interrupt Enable bit  
1 = Enables the RB port change interrupt  
0 = Disables the RB port change interrupt

bit 2: **TOIF:** TMR0 Overflow Interrupt Flag bit  
1 = TMR0 register has overflowed (must be cleared in software)  
0 = TMR0 register did not overflow

bit 1: **INTF:** RB0/INT External Interrupt Flag bit  
1 = The RB0/INT external interrupt occurred (must be cleared in software)  
0 = The RB0/INT external interrupt did not occur

bit 0: **RBIF:** RB Port Change Interrupt Flag bit  
1 = At least one of the RB7:RB4 pins changed state (must be cleared in software)  
0 = None of the RB7:RB4 pins have changed state

# PIC16C63A/65B/73B/74B

## 2.2.2.4 PIE1 REGISTER

This register contains the individual enable bits for the peripheral interrupts.

**Note:** Bit PEIE (INTCON<6>) must be set to enable any peripheral interrupt.

**FIGURE 2-6: PIE1 REGISTER (ADDRESS 8Ch)**

R/W-0	R/W-0	R/W-0	R/W-0	R/W-0	R/W-0	R/W-0	R/W-0
PSPIE <sup>(1)</sup>	ADIE <sup>(2)</sup>	RCIE	TXIE	SSPIE	CCP1IE	TMR2IE	TMR1IE
bit7							bit0

R = Readable bit  
W = Writable bit  
U = Unimplemented bit, read as '0'  
-n = Value at POR reset

bit 7: **PSPIE<sup>(1)</sup>**: Parallel Slave Port Read/Write Interrupt Enable bit  
1 = Enables the PSP read/write interrupt  
0 = Disables the PSP read/write interrupt

bit 6: **ADIE<sup>(2)</sup>**: A/D Converter Interrupt Enable bit  
1 = Enables the A/D interrupt  
0 = Disables the A/D interrupt

bit 5: **RCIE**: USART Receive Interrupt Enable bit  
1 = Enables the USART receive interrupt  
0 = Disables the USART receive interrupt

bit 4: **TXIE**: USART Transmit Interrupt Enable bit  
1 = Enables the USART transmit interrupt  
0 = Disables the USART transmit interrupt

bit 3: **SSPIE**: Synchronous Serial Port Interrupt Enable bit  
1 = Enables the SSP interrupt  
0 = Disables the SSP interrupt

bit 2: **CCP1IE**: CCP1 Interrupt Enable bit  
1 = Enables the CCP1 interrupt  
0 = Disables the CCP1 interrupt

bit 1: **TMR2IE**: TMR2 to PR2 Match Interrupt Enable bit  
1 = Enables the TMR2 to PR2 match interrupt  
0 = Disables the TMR2 to PR2 match interrupt

bit 0: **TMR1IE**: TMR1 Overflow Interrupt Enable bit  
1 = Enables the TMR1 overflow interrupt  
0 = Disables the TMR1 overflow interrupt

Note 1: PIC16C63A/73B devices do not have a Parallel Slave Port implemented. This bit location is reserved on these devices. Always maintain this bit clear.

Note 2: PIC16C63A/65B devices do not have an A/D module. This bit location is reserved on these devices. Always maintain this bit clear.

# PIC16C63A/65B/73B/74B

## 2.2.2.5 PIR1 REGISTER

This register contains the individual flag bits for the peripheral interrupts.

**Note:** Interrupt flag bits get set when an interrupt condition occurs regardless of the state of its corresponding enable bit or the global enable bit, GIE (INTCON<7>). User software should ensure the appropriate interrupt flag bits are clear prior to enabling an interrupt.

**FIGURE 2-7: PIR1 REGISTER (ADDRESS 0Ch)**

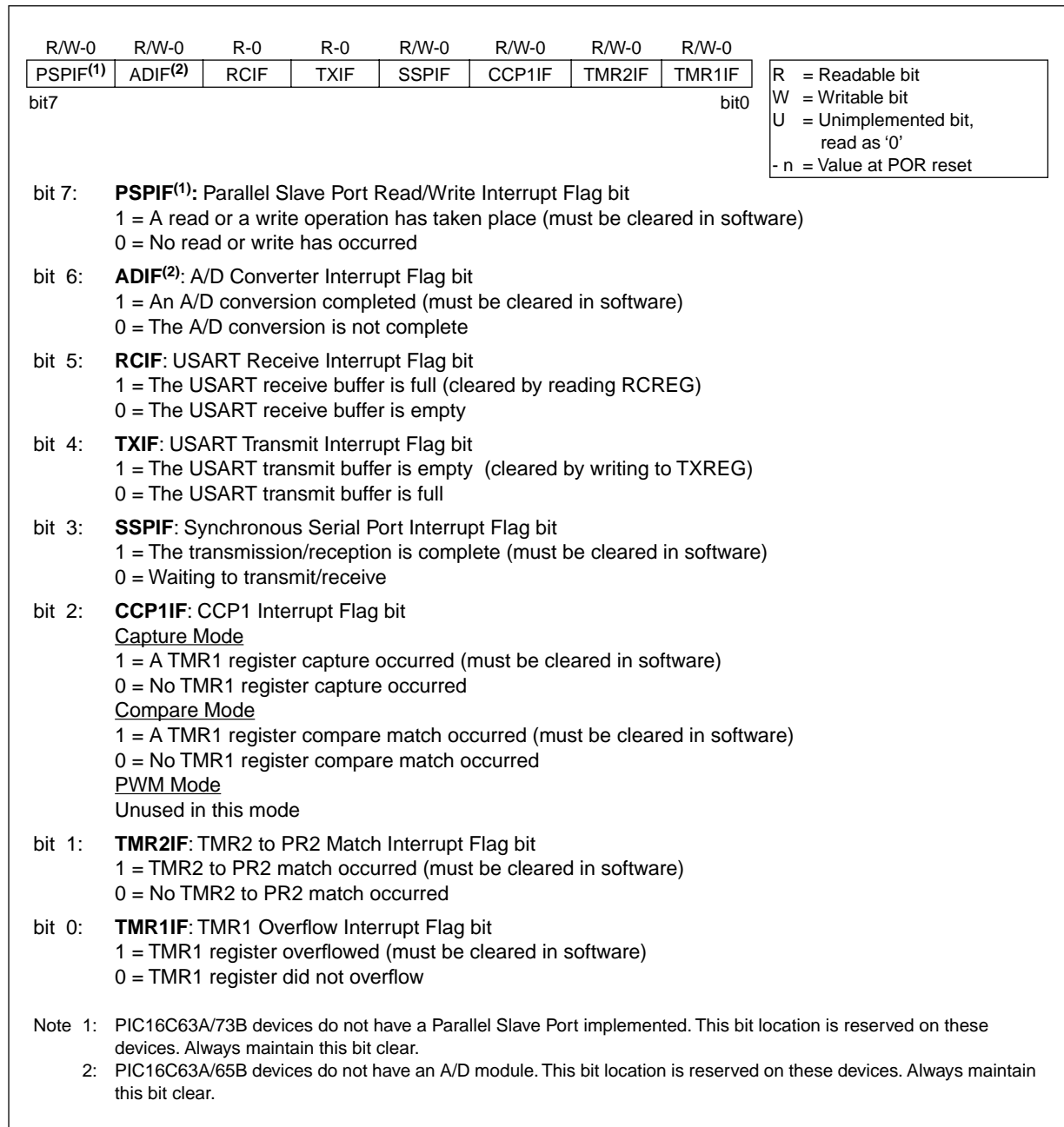

# PIC16C63A/65B/73B/74B

## 2.2.2.6 PIE2 REGISTER

This register contains the individual enable bit for the CCP2 peripheral interrupt.

**FIGURE 2-8: PIE2 REGISTER (ADDRESS 8Dh)**

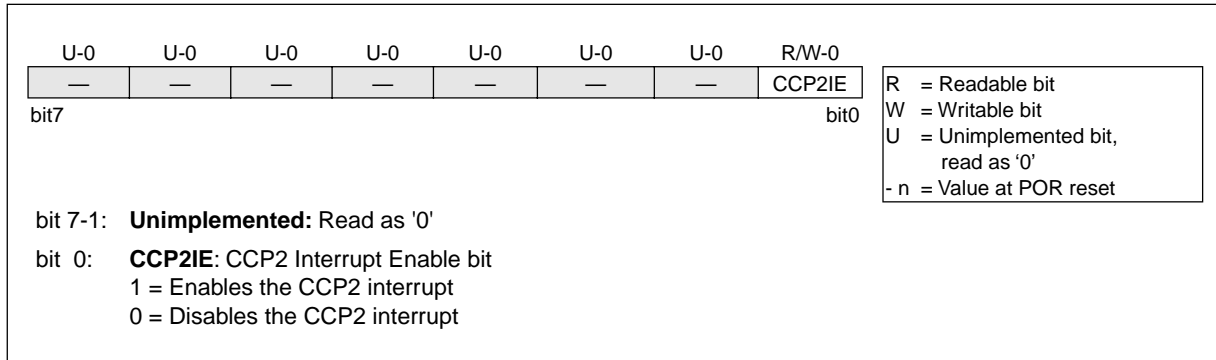

# PIC16C63A/65B/73B/74B

## 2.2.2.7 PIR2 REGISTER

This register contains the CCP2 interrupt flag bit.

**Note:** Interrupt flag bits get set when an interrupt condition occurs regardless of the state of its corresponding enable bit or the global enable bit, GIE (INTCON<7>). User software should ensure the appropriate interrupt flag bits are clear prior to enabling an interrupt.

**FIGURE 2-9: PIR2 REGISTER (ADDRESS 0Dh)**

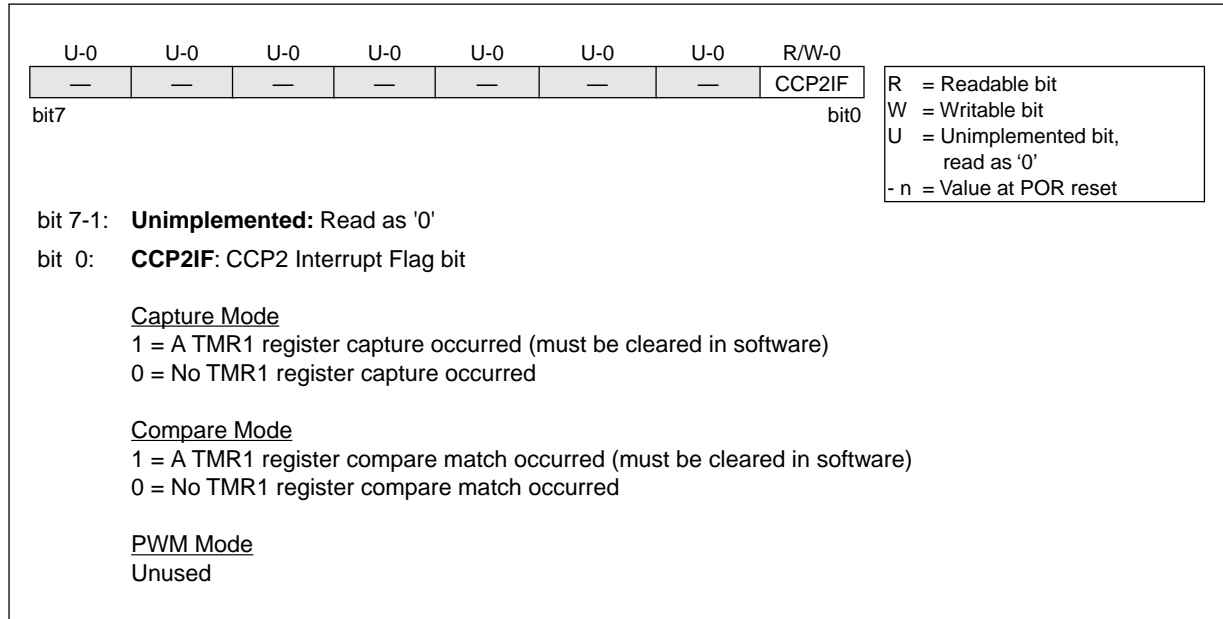

# PIC16C63A/65B/73B/74B

## 2.2.2.8 PCON REGISTER

The Power Control (PCON) register contains a flag bit to allow differentiation between a Power-on Reset (POR) to an external  $\overline{\text{MCLR}}$  Reset or WDT Reset. Those devices with brown-out detection circuitry contain an additional bit to differentiate a Brown-out Reset condition from a Power-on Reset condition.

**Note:** If the BODEN configuration bit is set,  $\overline{\text{BOR}}$  is '1' on Power-on Reset. If the BODEN configuration bit is clear,  $\overline{\text{BOR}}$  is unknown on Power-on Reset.

The  $\overline{\text{BOR}}$  status bit is a "don't care" and is not necessarily predictable if the brown-out circuit is disabled (the BODEN configuration bit is clear).  $\overline{\text{BOR}}$  must then be set by the user and checked on subsequent resets to see if it is clear, indicating a brown-out has occurred.

**FIGURE 2-10: PCON REGISTER (ADDRESS 8Eh)**

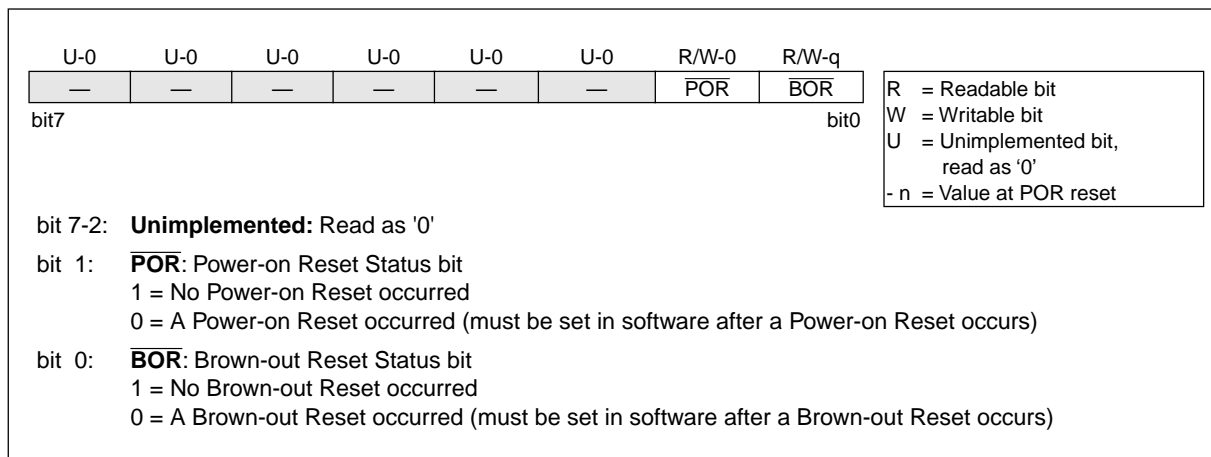

# PIC16C63A/65B/73B/74B

---

## 2.3 PCL and PCLATH

The program counter (PC) specifies the address of the instruction to fetch for execution. The PC is 13 bits wide. The low byte is called the PCL register. This register is readable and writable. The high byte is called the PCH register. This register contains the PC<12:8> bits and is not directly readable or writable. All updates to the PCH register go through the PCLATH register.

### 2.3.1 STACK

The stack allows a combination of up to 8 program calls and interrupts to occur. The stack contains the return address from this branch in program execution.

Mid-Range devices have an 8 level deep x 13-bit wide hardware stack. The stack space is not part of either program or data space and the stack pointer is not readable or writable. The PC is PUSHed onto the stack when a CALL instruction is executed or an interrupt causes a branch. The stack is POPed in the event of a RETURN, RETLW or a RETFIE instruction execution. PCLATH is not modified when the stack is PUSHed or POPed.

After the stack has been PUSHed eight times, the ninth push overwrites the value that was stored from the first push. The tenth push overwrites the second push (and so on).

## 2.4 Program Memory Paging

The CALL and GOTO instructions provide 11 bits of address to allow branching within any 2K program memory page. When doing a CALL or GOTO instruction the upper bit of the address is provided by PCLATH<3>. When doing a CALL or GOTO instruction, the user must ensure that the page select bit is programmed so that the desired program memory page is addressed. If a return from a CALL instruction (or interrupt) is executed, the entire 13-bit PC is pushed onto the stack. Therefore, manipulation of the PCLATH<3> bit is not required for the return instructions (which POPs the address from the stack).

# PIC16C63A/65B/73B/74B

## 2.5 Indirect Addressing, INDF and FSR Registers

The INDF register is not a physical register. Addressing INDF actually addresses the register whose address is contained in the FSR register (FSR is a *pointer*). This is indirect addressing.

### EXAMPLE 2-1: INDIRECT ADDRESSING

- Register file 05 contains the value 10h
- Register file 06 contains the value 0Ah
- Load the value 05 into the FSR register
- A read of the INDF register will return the value of 10h
- Increment the value of the FSR register by one (FSR = 06)
- A read of the INDF register now will return the value of 0Ah.

Reading INDF itself indirectly (FSR = 0) will produce 00h. Writing to the INDF register indirectly results in a no-operation (although STATUS bits may be affected).

A simple program to clear RAM locations 20h-2Fh using indirect addressing is shown in Example 2-2.

### EXAMPLE 2-2: HOW TO CLEAR RAM USING INDIRECT ADDRESSING

```

movlw 0x20 ;initialize pointer
movwf FSR ; to RAM
NEXT   clrf INDF ;clear INDF register
       incf FSR ;inc pointer
       btfss FSR,4 ;all done?
       goto NEXT ;NO, clear next

CONTINUE
:      ;YES, continue
    
```

An effective 9-bit address is obtained by concatenating the 8-bit FSR register and the IRP bit (STATUS<7>), as shown in Figure 2-11. However, IRP is not used in the PIC16C63A/65B/73B/74B.

FIGURE 2-11: DIRECT/INDIRECT ADDRESSING

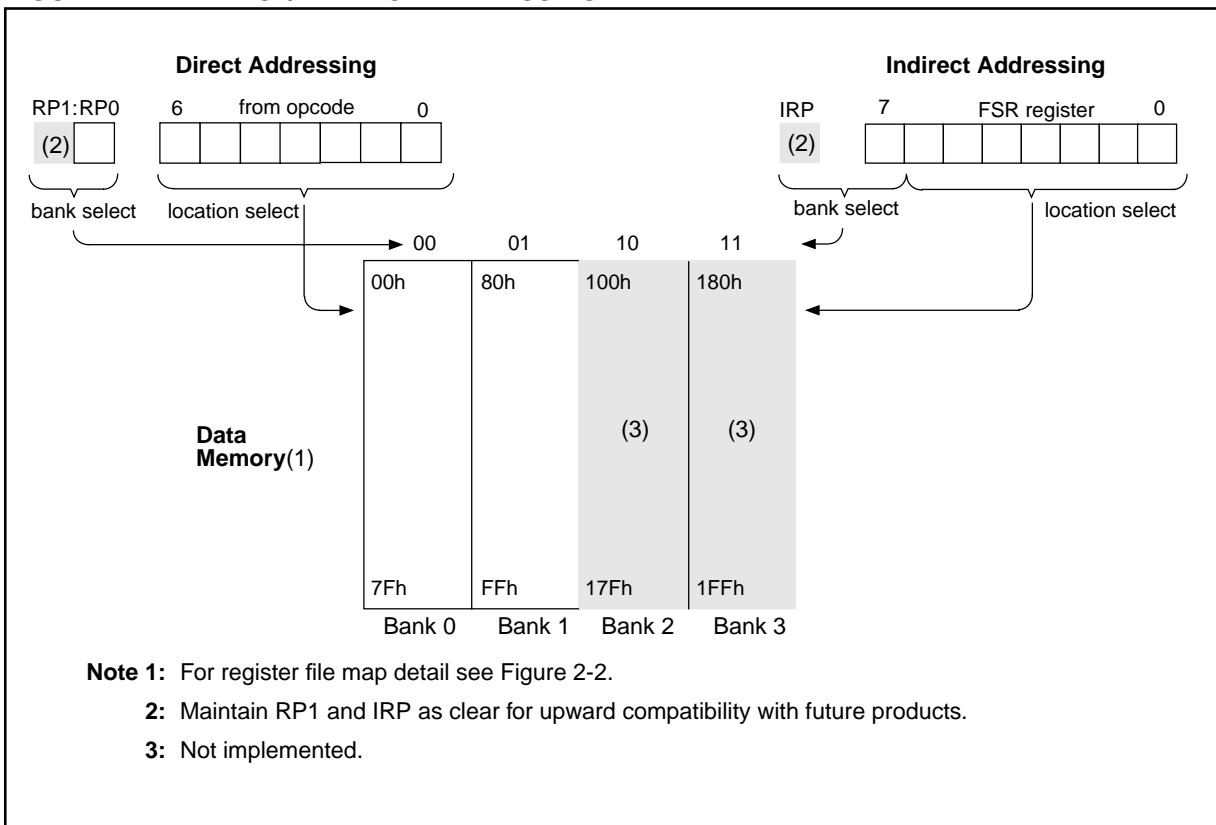



# PIC16C63A/65B/73B/74B

## 3.0 I/O PORTS

Some pins for these I/O ports are multiplexed with an alternate function for the peripheral features on the device. In general, when a peripheral is enabled, that pin may not be used as a general purpose I/O pin.

Additional information on I/O ports may be found in the PICmicro™ Mid-Range Reference Manual, (DS33023).

### 3.1 PORTA and the TRISA Register

PORTA is a 6-bit wide bi-directional port. The corresponding data direction register is TRISA. Setting a TRISA bit (=1) will make the corresponding PORTA pin an input, i.e., put the corresponding output driver in a hi-impedance mode. Clearing a TRISA bit (=0) will make the corresponding PORTA pin an output, i.e., put the contents of the output latch on the selected pin.

**Note:** On a Power-on Reset, these pins are configured as inputs and read as '0'.

Reading the PORTA register reads the status of the pins, whereas writing to it will write to the port latch. All write operations are read-modify-write operations. Therefore, a write to a port implies that the port pins are read. This value is modified and then written to the port data latch.

Pin RA4 is multiplexed with the Timer0 module clock input to become the RA4/T0CKI pin. The RA4/T0CKI pin is a Schmitt Trigger input and an open drain output. All other RA port pins have TTL input levels and full CMOS output drivers.

On PIC16C73B/74B devices, other PORTA pins are multiplexed with analog inputs and analog VREF input. The operation of each pin is selected by clearing/setting the control bits in the ADCON1 register (A/D Control Register1).

**Note:** On a Power-on Reset, these pins are configured as analog inputs and read as '0'.

The TRISA register controls the direction of the RA pins, even when they are being used as analog inputs. The user must ensure the bits in the TRISA register are maintained set when using them as analog inputs.

#### EXAMPLE 3-1: INITIALIZING PORTA

```
BCF STATUS, RP0 ;
CLRF PORTA      ; Initialize PORTA by
                ; clearing output
                ; data latches

BSF STATUS, RP0 ; Select Bank 1
MOVLW 0xCF      ; Value used to
                ; initialize data
                ; direction
MOVWF TRISA     ; Set RA<3:0> as inputs
                ; RA<5:4> as outputs
                ; TRISA<7:6> are always
                ; read as '0'.
```

FIGURE 3-1: BLOCK DIAGRAM OF RA3:RA0 AND RA5 PINS

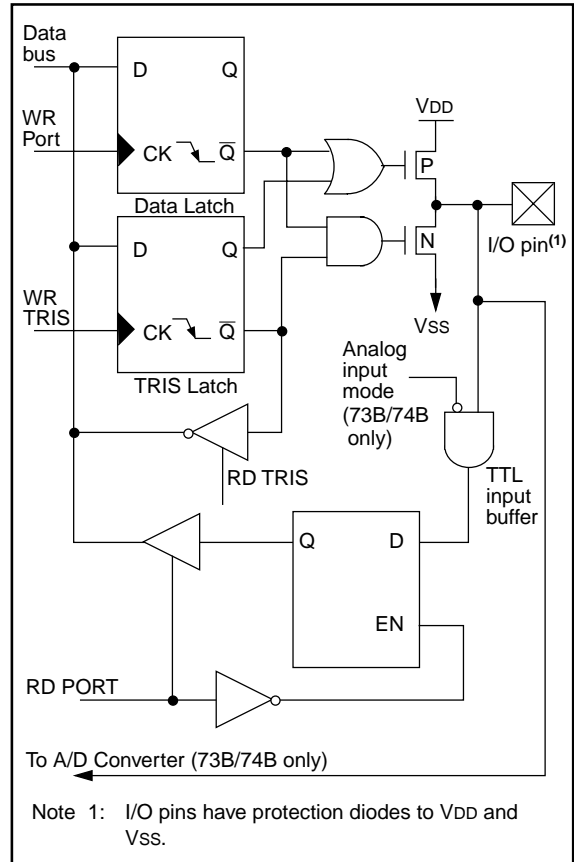
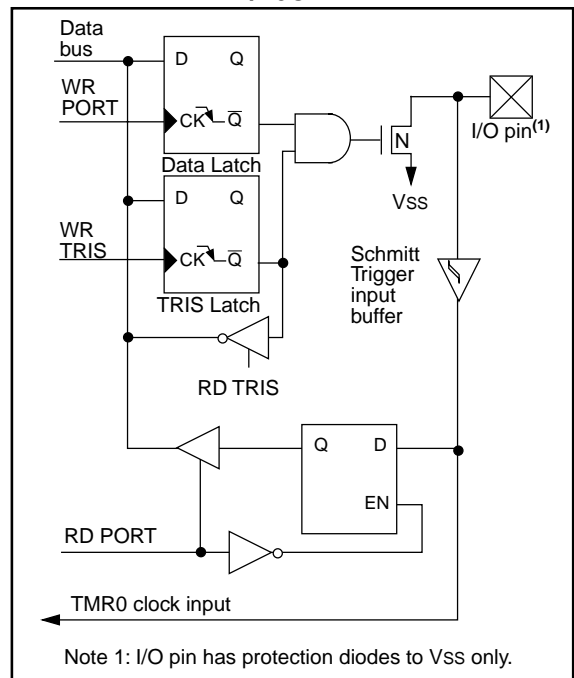

FIGURE 3-2: BLOCK DIAGRAM OF RA4/T0CKI PIN



# PIC16C63A/65B/73B/74B

**TABLE 3-1: PORTA FUNCTIONS**

Name	Bit#	Buffer	Function
RA0/AN0	bit0	TTL	Input/output or analog input <sup>(1)</sup>
RA1/AN1	bit1	TTL	Input/output or analog input <sup>(1)</sup>
RA2/AN2	bit2	TTL	Input/output or analog input <sup>(1)</sup>
RA3/AN3/VREF	bit3	TTL	Input/output or analog input <sup>(1)</sup> or VREF <sup>(1)</sup>
RA4/T0CKI	bit4	ST	Input/output or external clock input for Timer0 Output is open drain type
RA5/ $\overline{SS}$ /AN4	bit5	TTL	Input/output or slave select input for synchronous serial port or analog input <sup>(1)</sup>

Legend: TTL = TTL input, ST = Schmitt Trigger input

**Note 1:** On PIC16C73B/74B devices only.

**TABLE 3-2: SUMMARY OF REGISTERS ASSOCIATED WITH PORTA**

Address	Name	Bit 7	Bit 6	Bit 5	Bit 4	Bit 3	Bit 2	Bit 1	Bit 0	Value on POR, BOR	Value on all other resets
05h	PORTA	—	—	RA5	RA4	RA3	RA2	RA1	RA0	--0x 0000	--0u 0000
85h	TRISA	—	—	PORTA Data Direction Register						--11 1111	--11 1111
9Fh	ADCON1 <sup>(1)</sup>	—	—	—	—	—	PCFG2	PCFG1	PCFG0	---- -000	---- -000

Legend: x = unknown, u = unchanged, - = unimplemented locations read as '0'. Shaded cells are not used by PORTA.

**Note 1:** On PIC16C73B/74B devices only.

# PIC16C63A/65B/73B/74B

## 3.2 PORTB and the TRISB Register

PORTB is an 8-bit wide bi-directional port. The corresponding data direction register is TRISB. Setting a TRISB bit (=1) will make the corresponding PORTB pin an input, i.e., put the corresponding output driver in a hi-impedance mode. Clearing a TRISB bit (=0) will make the corresponding PORTB pin an output, i.e., put the contents of the output latch on the selected pin.

### EXAMPLE 3-1: INITIALIZING PORTB

```
BCF STATUS, RP0 ;
CLRF PORTB      ; Initialize PORTB by
                ; clearing output
                ; data latches

BSF STATUS, RP0 ; Select Bank 1
MOVLW 0xCF      ; Value used to
                ; initialize data
                ; direction

MOVWF TRISB     ; Set RB<3:0> as inputs
                ; RB<5:4> as outputs
                ; RB<7:6> as inputs
```

Each of the PORTB pins has a weak internal pull-up. A single control bit can turn on all the pull-ups. This is performed by clearing bit RBPŪ (OPTION\_REG<7>). The weak pull-up is automatically turned off when the port pin is configured as an output. The pull-ups are disabled on a Power-on Reset.

**FIGURE 3-3: BLOCK DIAGRAM OF RB3:RB0 PINS**

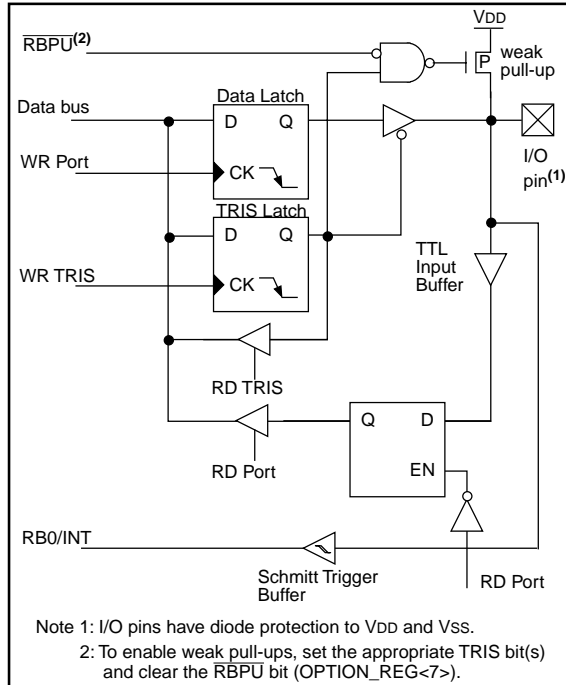

Four of PORTB's pins, RB7:RB4, have an interrupt on change feature. Only pins configured as inputs can cause this interrupt to occur (i.e. any RB7:RB4 pin configured as an output is excluded from the interrupt on change comparison). The input pins (of RB7:RB4) are compared with the old value latched on the last read of PORTB. The "mismatch" outputs of RB7:RB4 are OR'ed together to generate the RB Port Change Interrupt with flag bit RBIF (INTCON<0>).

This interrupt can wake the device from SLEEP. The user, in the interrupt service routine, can clear the interrupt in the following manner:

- Any read or write of PORTB. This will end the mismatch condition.
- Clear flag bit RBIF.

A mismatch condition will continue to set flag bit RBIF. Reading PORTB will end the mismatch condition, and allow flag bit RBIF to be cleared.

The interrupt on change feature is recommended for wake-up on key depression operation and operations where PORTB is only used for the interrupt on change feature. Polling of PORTB is not recommended while using the interrupt on change feature.

**FIGURE 3-4: BLOCK DIAGRAM OF RB7:RB4 PINS**

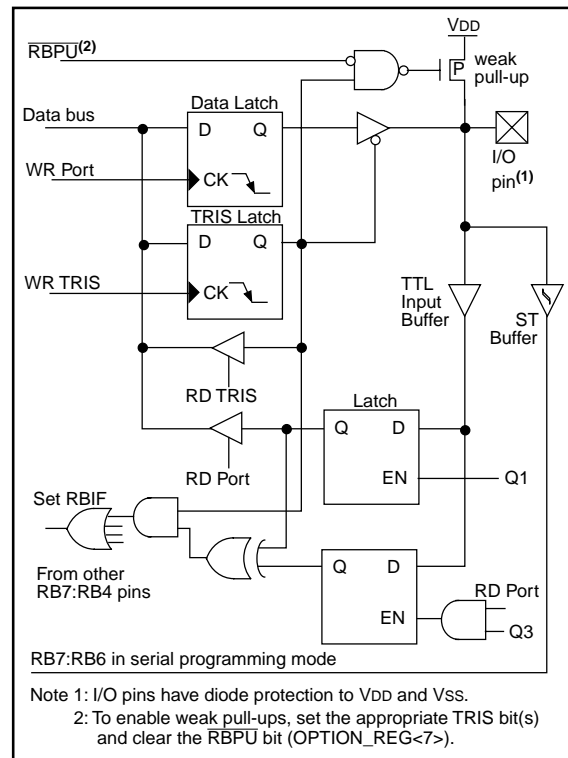

# PIC16C63A/65B/73B/74B

**TABLE 3-3: PORTB FUNCTIONS**

Name	Bit#	Buffer	Function
RB0/INT	bit0	TTL/ST <sup>(1)</sup>	Input/output pin or external interrupt input. Internal software programmable weak pull-up.
RB1	bit1	TTL	Input/output pin. Internal software programmable weak pull-up.
RB2	bit2	TTL	Input/output pin. Internal software programmable weak pull-up.
RB3	bit3	TTL	Input/output pin. Internal software programmable weak pull-up.
RB4	bit4	TTL	Input/output pin (with interrupt on change). Internal software programmable weak pull-up.
RB5	bit5	TTL	Input/output pin (with interrupt on change). Internal software programmable weak pull-up.
RB6	bit6	TTL/ST <sup>(2)</sup>	Input/output pin (with interrupt on change). Internal software programmable weak pull-up. Serial programming clock.
RB7	bit7	TTL/ST <sup>(2)</sup>	Input/output pin (with interrupt on change). Internal software programmable weak pull-up. Serial programming data.

Legend: TTL = TTL input, ST = Schmitt Trigger input

Note 1: This buffer is a Schmitt Trigger input when configured as the external interrupt.

2: This buffer is a Schmitt Trigger input when used in serial programming mode.

**TABLE 3-4: SUMMARY OF REGISTERS ASSOCIATED WITH PORTB**

Address	Name	Bit 7	Bit 6	Bit 5	Bit 4	Bit 3	Bit 2	Bit 1	Bit 0	Value on POR, BOR	Value on all other resets
06h	PORTB	RB7	RB6	RB5	RB4	RB3	RB2	RB1	RB0	xxxx xxxx	uuuu uuuu
86h	TRISB	PORTB Data Direction Register								1111 1111	1111 1111
81h	OPTION_REG	RBPU	INTEDG	T0CS	T0SE	PSA	PS2	PS1	PS0	1111 1111	1111 1111

Legend: x = unknown, u = unchanged. Shaded cells are not used by PORTB.

# PIC16C63A/65B/73B/74B

## 3.3 PORTC and the TRISC Register

PORTC is an 8-bit wide bi-directional port. The corresponding data direction register is TRISC. Setting a TRISC bit (=1) will make the corresponding PORTC pin an input, i.e., put the corresponding output driver in a hi-impedance mode. Clearing a TRISC bit (=0) will make the corresponding PORTC pin an output, i.e., put the contents of the output latch on the selected pin.

PORTC is multiplexed with several peripheral functions (Table 3-5). PORTC pins have Schmitt Trigger input buffers.

When enabling peripheral functions, care should be taken in defining TRIS bits for each PORTC pin. Some peripherals override the TRIS bit to make a pin an output, while other peripherals override the TRIS bit to make a pin an input. Since the TRIS bit override is in effect while the peripheral is enabled, read-modify-write instructions (BSF, BCF, XORWF) with TRISC as destination should be avoided. The user should refer to the corresponding peripheral section for the correct TRIS bit settings.

### EXAMPLE 3-1: INITIALIZING PORTC

```
BCF    STATUS, RP0    ; Select Bank 0
CLRF   PORTC          ; Initialize PORTC by
                        ; clearing output
                        ; data latches
BSF    STATUS, RP0    ; Select Bank 1
MOVLW  0xCF           ; Value used to
                        ; initialize data
                        ; direction
MOVWF  TRISC          ; Set RC<3:0> as inputs
                        ; RC<5:4> as outputs
                        ; RC<7:6> as inputs
```

FIGURE 3-5: PORTC BLOCK DIAGRAM (PERIPHERAL OUTPUT OVERRIDE)

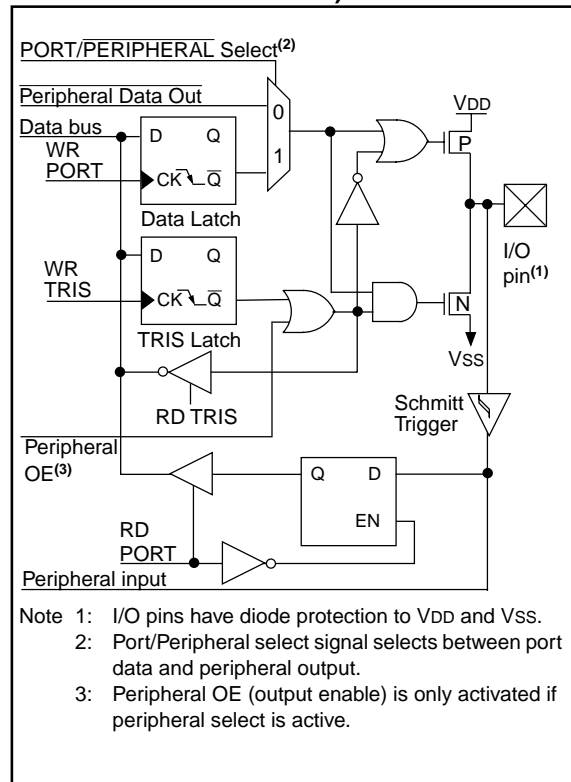

# PIC16C63A/65B/73B/74B

**TABLE 3-5: PORTC FUNCTIONS**

Name	Bit#	Buffer Type	Function
RC0/T1OSO/T1CKI	bit0	ST	Input/output port pin or Timer1 oscillator output/Timer1 clock input
RC1/T1OSI	bit1	ST	Input/output port pin or Timer1 oscillator input
RC2/CCP1	bit2	ST	Input/output port pin or Capture1 input/Compare1 output/PWM1 output
RC3/SCK/SCL	bit3	ST	RC3 can also be the synchronous serial clock for both SPI and I <sup>2</sup> C modes.
RC4/SDI/SDA	bit4	ST	RC4 can also be the SPI Data In (SPI mode) or data I/O (I <sup>2</sup> C mode).
RC5/SDO	bit5	ST	Input/output port pin or Synchronous Serial Port data output
RC6	bit6	ST	Input/output port pin
RC7	bit7	ST	Input/output port pin

Legend: ST = Schmitt Trigger input

**TABLE 3-6: SUMMARY OF REGISTERS ASSOCIATED WITH PORTC**

Address	Name	Bit 7	Bit 6	Bit 5	Bit 4	Bit 3	Bit 2	Bit 1	Bit 0	Value on POR, BOR	Value on all other resets
07h	PORTC	RC7	RC6	RC5	RC4	RC3	RC2	RC1	RC0	xxxx xxxx	uuuu uuuu
87h	TRISC	PORTC Data Direction Register								1111 1111	1111 1111

Legend: x = unknown, u = unchanged.

## 3.4 PORTD and TRISD Registers

This section is applicable to the PIC16C65B/PIC16C74B devices only.

PORTD is an 8-bit port with Schmitt Trigger input buffers. Each pin is individually configurable as an input or output.

PORTD can be configured as an 8-bit wide microprocessor port (parallel slave port) by setting control bit PSPMODE (TRISE<4>). In this mode, the input buffers are TTL.

**FIGURE 3-6: PORTD BLOCK DIAGRAM (IN I/O PORT MODE)**

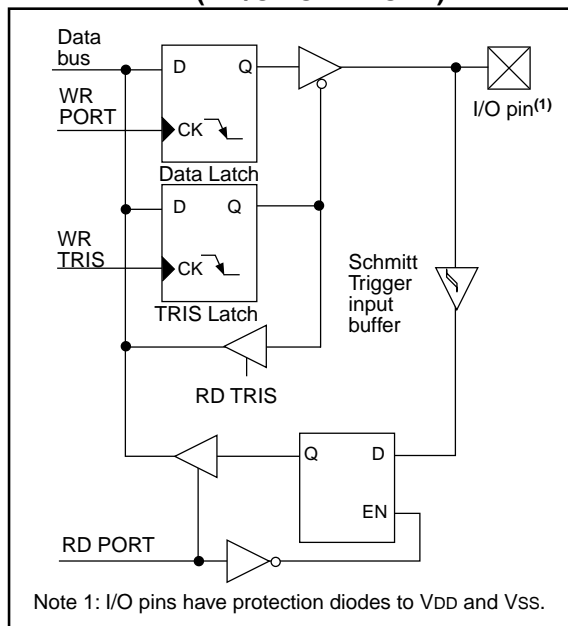

# PIC16C63A/65B/73B/74B

**TABLE 3-7: PORTD FUNCTIONS**

Name	Bit#	Buffer Type	Function
RD0/PSP0	bit0	ST/TTL <sup>(1)</sup>	Input/output port pin or parallel slave port bit0
RD1/PSP1	bit1	ST/TTL <sup>(1)</sup>	Input/output port pin or parallel slave port bit1
RD2/PSP2	bit2	ST/TTL <sup>(1)</sup>	Input/output port pin or parallel slave port bit2
RD3/PSP3	bit3	ST/TTL <sup>(1)</sup>	Input/output port pin or parallel slave port bit3
RD4/PSP4	bit4	ST/TTL <sup>(1)</sup>	Input/output port pin or parallel slave port bit4
RD5/PSP5	bit5	ST/TTL <sup>(1)</sup>	Input/output port pin or parallel slave port bit5
RD6/PSP6	bit6	ST/TTL <sup>(1)</sup>	Input/output port pin or parallel slave port bit6
RD7/PSP7	bit7	ST/TTL <sup>(1)</sup>	Input/output port pin or parallel slave port bit7

Legend: ST = Schmitt Trigger input TTL = TTL input

Note 1: Input buffers are Schmitt Triggers when in I/O mode and TTL buffer when in Parallel Slave Port Mode.

**TABLE 3-8: SUMMARY OF REGISTERS ASSOCIATED WITH PORTD**

Address	Name	Bit 7	Bit 6	Bit 5	Bit 4	Bit 3	Bit 2	Bit 1	Bit 0	Value on POR, BOR	Value on all other resets
08h	PORTD	RD7	RD6	RD5	RD4	RD3	RD2	RD1	RD0	xxxx xxxx	uuuu uuuu
88h	TRISD	PORTD Data Direction Register								1111 1111	1111 1111
89h	TRISE	IBF	OBF	IBOV	PSPMODE	—	PORTE Data Direction Bits			0000 -111	0000 -111

Legend: x = unknown, u = unchanged, - = unimplemented read as '0'. Shaded cells are not used by PORTD.



# PIC16C63A/65B/73B/74B

## 3.5 PORTE and TRISE Register

This section is applicable to the PIC16C65B/PIC16C74B devices only. The A/D multiplexed functions are available on the PIC16C74B only.

PORTE has three pins RE0/ $\overline{RD}$ /AN5, RE1/ $\overline{WR}$ /AN6 and RE2/ $\overline{CS}$ /AN7, which are individually configurable as inputs or outputs. These pins have Schmitt Trigger input buffers.

I/O PORTE becomes control inputs for the microprocessor port when bit PSPMODE (TRISE<4>) is set. In this mode, the user must make sure that the TRISE<2:0> bits are set (pins are configured as digital inputs). For the PIC16C74B ensure ADCON1 is configured for digital I/O. In this mode, the input buffers are TTL.

Figure 3-8 shows the TRISE register, which also controls the parallel slave port operation.

PORTE pins for the PIC16C74B only are multiplexed with analog inputs. When selected as an analog input, these pins will read as '0's.

TRISE controls the direction of the RE pins, even when they are being used as analog inputs. The user must make sure to keep the pins configured as inputs when using them as analog inputs.

**Note:** On a Power-on Reset these pins are configured as analog inputs.

**FIGURE 3-7: PORTE BLOCK DIAGRAM (IN I/O PORT MODE)**

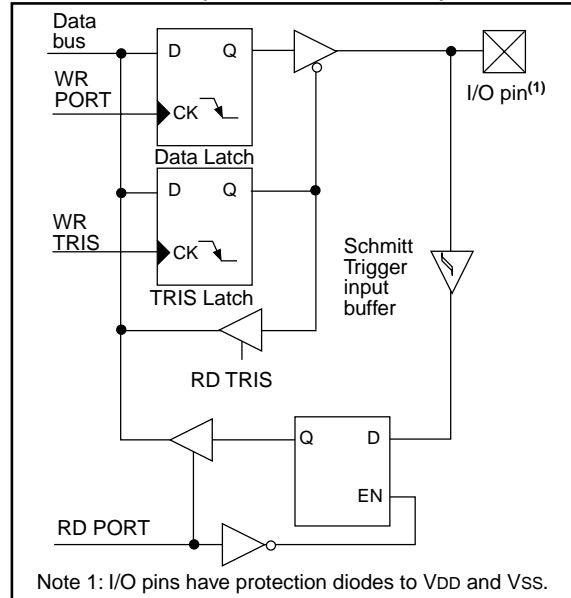

**FIGURE 3-8: TRISE REGISTER (ADDRESS 89h)**

R-0	R-0	R/W-0	R/W-0	U-0	R/W-1	R/W-1	R/W-1	
IBF	OBF	IBOV	PSPMODE	—	TRISE2	TRISE1	TRISE0	
bit7								bit0

R = Readable bit  
 W = Writable bit  
 U = Unimplemented bit, read as '0'  
 - n = Value at POR reset

bit 7: **IBF:** Input Buffer Full Status bit  
 1 = A word has been received and is waiting to be read by the CPU  
 0 = No word has been received

bit 6: **OBF:** Output Buffer Full Status bit  
 1 = The output buffer still holds a previously written word  
 0 = The output buffer has been read

bit 5: **IBOV:** Input Buffer Overflow Detect bit (in microprocessor mode)  
 1 = A write occurred when a previously input word has not been read (must be cleared in software)  
 0 = No overflow occurred

bit 4: **PSPMODE:** Parallel Slave Port Mode Select bit  
 1 = Parallel slave port mode  
 0 = General purpose I/O mode

bit 3: **Unimplemented:** Read as '0'

bit 2: **TRISE2:** RE2 Direction Control bit  
 1 = Input  
 0 = Output

bit 1: **TRISE1:** RE2 Direction Control bit  
 1 = Input  
 0 = Output

bit 0: **TRISE0:** RE2 Direction Control bit  
 1 = Input  
 0 = Output

# PIC16C63A/65B/73B/74B

**TABLE 3-9: PORTE FUNCTIONS**

Name	Bit#	Buffer Type	Function
RE0/ $\overline{RD}$ /AN5 <sup>(2)</sup>	bit0	ST/TTL <sup>(1)</sup>	Input/output port pin or read control input in parallel slave port mode or analog input: $\overline{RD}$ 1 = Not a read operation 0 = Read operation. Reads PORTD register (if chip selected)
RE1/ $\overline{WR}$ /AN6 <sup>(2)</sup>	bit1	ST/TTL <sup>(1)</sup>	Input/output port pin or write control input in parallel slave port mode or analog input: $\overline{WR}$ 1 = Not a write operation 0 = Write operation. Writes PORTD register (if chip selected)
RE2/ $\overline{CS}$ /AN7 <sup>(2)</sup>	bit2	ST/TTL <sup>(1)</sup>	Input/output port pin or chip select control input in parallel slave port mode or analog input: $\overline{CS}$ 1 = Device is not selected 0 = Device is selected

Legend: ST = Schmitt Trigger input TTL = TTL input

Note 1: Input buffers are Schmitt Triggers when in I/O mode and TTL buffers when in Parallel Slave Port Mode.

Note 2: A/D Converter module multiplexing is implemented on the PIC16C74B only.

**TABLE 3-10: SUMMARY OF REGISTERS ASSOCIATED WITH PORTE**

Addr	Name	Bit 7	Bit 6	Bit 5	Bit 4	Bit 3	Bit 2	Bit 1	Bit 0	Value on POR, BOR	Value on all other resets
09h	PORTE	—	—	—	—	—	RE2	RE1	RE0	---- -xxx	---- -uuu
89h	TRISE	IBF	OBF	IBOV	PSPMODE	—	PORTE Data Direction Bits			0000 -111	0000 -111
9Fh	ADCON1 <sup>(1)</sup>	—	—	—	—	—	PCFG2	PCFG1	PCFG0	---- -000	---- -000

Legend: x = unknown, u = unchanged, - = unimplemented read as '0'. Shaded cells are not used by PORTE.

Note 1: A/D Converter module multiplexing is implemented on the PIC16C74B only.

# PIC16C63A/65B/73B/74B

## 3.6 Parallel Slave Port

The Parallel Slave Port is implemented on the 40-pin devices only (PIC16C65B and PIC16C74B).

PORTD operates as an 8-bit wide Parallel Slave Port, or microprocessor port when control bit PSPMODE (TRISE<4>) is set. In slave mode it is asynchronously readable and writable by the external world through  $\overline{RD}$  control input pin RE0/ $\overline{RD}$  and  $\overline{WR}$  control input pin RE1/ $\overline{WR}$ .

It can directly interface to an 8-bit microprocessor data bus. The external microprocessor can read or write the PORTD latch as an 8-bit latch. Setting bit PSPMODE enables port pin RE0/ $\overline{RD}$  to be the  $\overline{RD}$  input, RE1/ $\overline{WR}$  to be the  $\overline{WR}$  input and RE2/ $\overline{CS}$  to be the  $\overline{CS}$  (chip select) input. For this functionality, the corresponding data direction bits of the TRISE register (TRISE<2:0>) must be configured as inputs (set). For the PIC16C74B, the A/D port configuration bits PCFG2:PCFG0 (ADCON1<2:0>) must be set, which will configure pins RE2:RE0 as digital I/O.

A write to the PSP occurs when both the  $\overline{CS}$  and  $\overline{WR}$  lines are first detected low. A read from the PSP occurs when both the  $\overline{CS}$  and  $\overline{RD}$  lines are first detected low.

FIGURE 3-9: PORTD AND PORTE BLOCK DIAGRAM (PARALLEL SLAVE PORT)

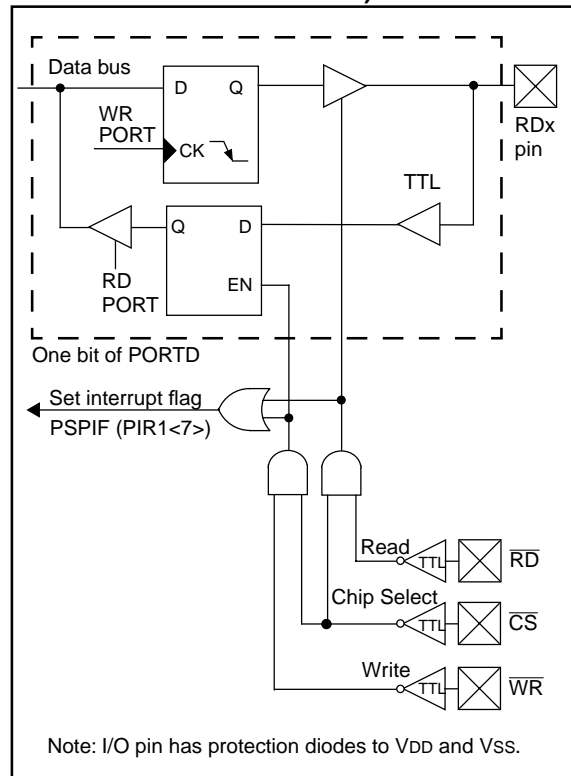
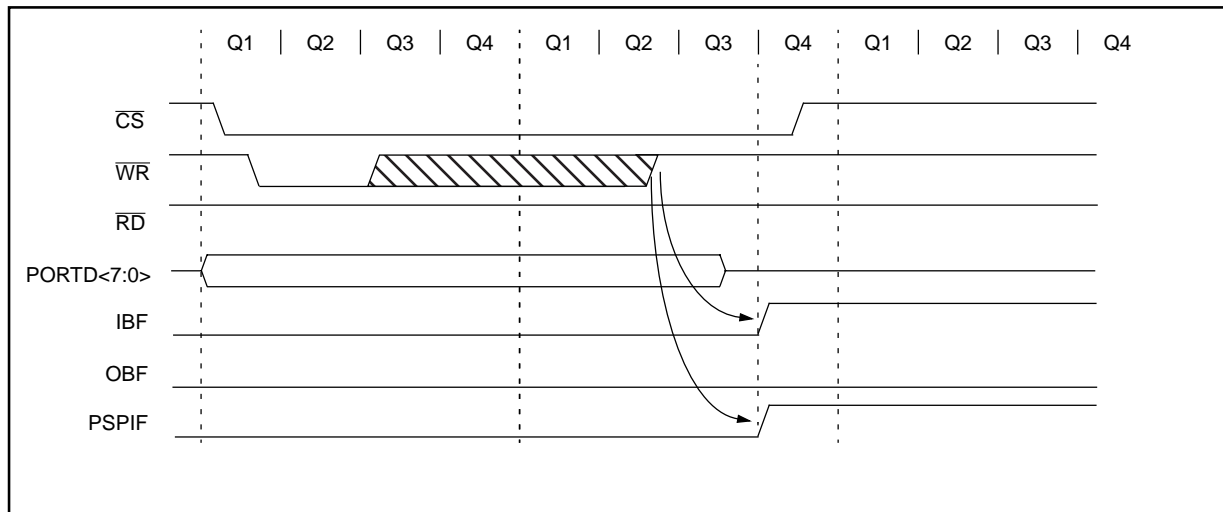
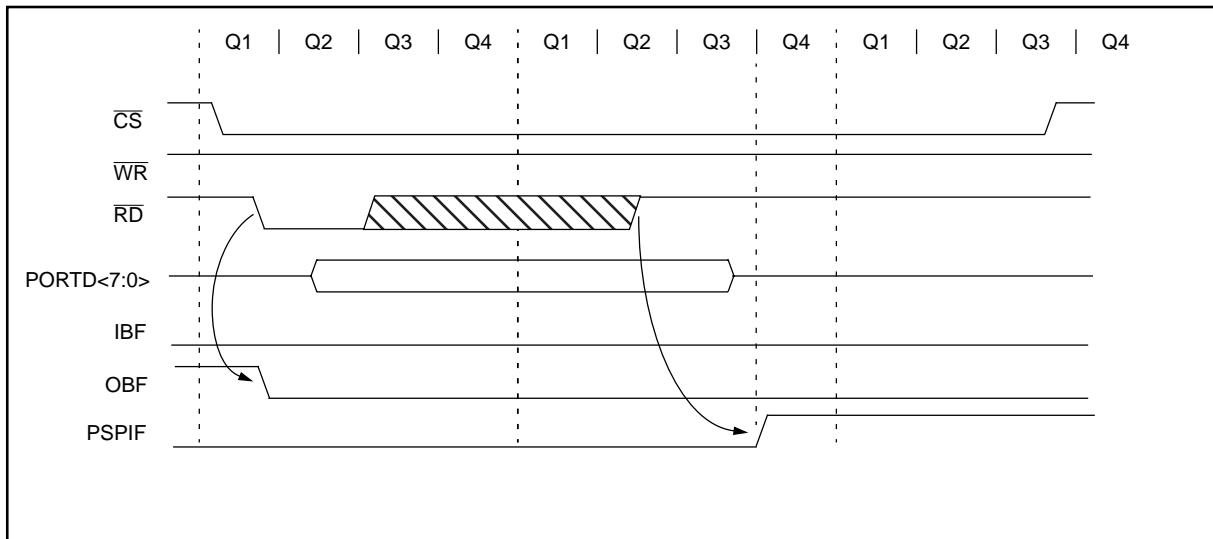

FIGURE 3-10: PARALLEL SLAVE PORT WRITE WAVEFORMS



# PIC16C63A/65B/73B/74B

**FIGURE 3-11: PARALLEL SLAVE PORT READ WAVEFORMS**



**TABLE 3-11: REGISTERS ASSOCIATED WITH PARALLEL SLAVE PORT**

Addr.	Name	Bit 7	Bit 6	Bit 5	Bit 4	Bit 3	Bit 2	Bit 1	Bit 0	Value on POR, BOR	Value on all other resets
08h	PORTD	Port data latch when written: Port pins when read								xxxx xxxx	uuuu uuuu
09h	PORTE	—	—	—	—	—	RE2	RE1	RE0	---- -xxx	---- -uuu
89h	TRISE	IBF	OBF	IBOV	PSPMODE	—	PORTE Data Direction Bits			0000 -111	0000 -111
0Ch	PIR1	PSPIF	ADIF <sup>(1)</sup>	RCIF	TXIF	SSPIF	CCP1IF	TMR2IF	TMR1IF	0000 0000	0000 0000
8Ch	PIE1	PSPIE	ADIE <sup>(1)</sup>	RCIE	TXIE	SSPIE	CCP1IE	TMR2IE	TMR1IE	0000 0000	0000 0000
9Fh	ADCON1 <sup>(1)</sup>	—	—	—	—	—	PCFG2	PCFG1	PCFG0	---- -000	---- -000

Legend: x = unknown, u = unchanged, - = unimplemented read as '0'. Shaded cells are not used by the Parallel Slave Port.

Note 1: On PIC16C74B only.

# PIC16C63A/65B/73B/74B

## 4.0 TIMER0 MODULE

The Timer0 module timer/counter has the following features:

- 8-bit timer/counter
- Readable and writable
- Internal or external clock select
- Edge select for external clock
- 8-bit software programmable prescaler
- Interrupt on overflow from FFh to 00h

Figure 4-1 is a simplified block diagram of the Timer0 module.

Additional information on timer modules is available in the PICmicro™ Mid-Range Reference Manual, (DS33023).

### 4.1 Timer0 Operation

Timer0 can operate as a timer or as a counter.

Timer mode is selected by clearing bit T0CS (OPTION\_REG<5>). In timer mode, the Timer0 module will increment every instruction cycle (without prescaler). If the TMR0 register is written, the increment is inhibited for the following two instruction cycles. The user can work around this by writing an adjusted value to the TMR0 register.

Counter mode is selected by setting bit T0CS (OPTION\_REG<5>). In counter mode, Timer0 will increment either on every rising or falling edge of pin RA4/T0CKI. The incrementing edge is determined by the Timer0 Source Edge Select bit T0SE (OPTION\_REG<4>). Clearing bit T0SE selects the rising edge. Restrictions on the external clock input are discussed below.

When an external clock input is used for Timer0, it must meet certain requirements. The requirements ensure the external clock can be synchronized with the internal phase clock (Tosc). There is a delay in the actual incrementing of Timer0 after synchronization.

Additional information on external clock requirements is available in the PICMicro™ Mid-Range Reference Manual, (DS33023).

### 4.2 Prescaler

An 8-bit counter is available as a prescaler for the Timer0 module, or as a postscaler for the Watchdog Timer, respectively (Figure 4-2). For simplicity, this counter is being referred to as “prescaler” throughout this data sheet. Note that there is only one prescaler available, which is mutually exclusively shared between the Timer0 module and the Watchdog Timer. Thus, a prescaler assignment for the Timer0 module means that there is no prescaler for the Watchdog Timer and vice-versa.

The prescaler is not readable or writable.

The PSA and PS2:PS0 bits (OPTION\_REG<3:0>) determine the prescaler assignment and prescale ratio.

Clearing bit PSA will assign the prescaler to the Timer0 module. When the prescaler is assigned to the Timer0 module, prescale values of 1:2, 1:4, ..., 1:256 are selectable.

Setting bit PSA will assign the prescaler to the Watchdog Timer (WDT). When the prescaler is assigned to the WDT, prescale values of 1:1, 1:2, ..., 1:128 are selectable.

When assigned to the Timer0 module, all instructions writing to the TMR0 register (e.g. CLRF 1, MOVWF 1, BSF 1, x....etc.) will clear the prescaler. When assigned to WDT, a CLRWDT instruction will clear the prescaler along with the WDT.

**Note:** Writing to TMR0 when the prescaler is assigned to Timer0 will clear the prescaler count, but will not change the prescaler assignment.

FIGURE 4-1: TIMER0 BLOCK DIAGRAM

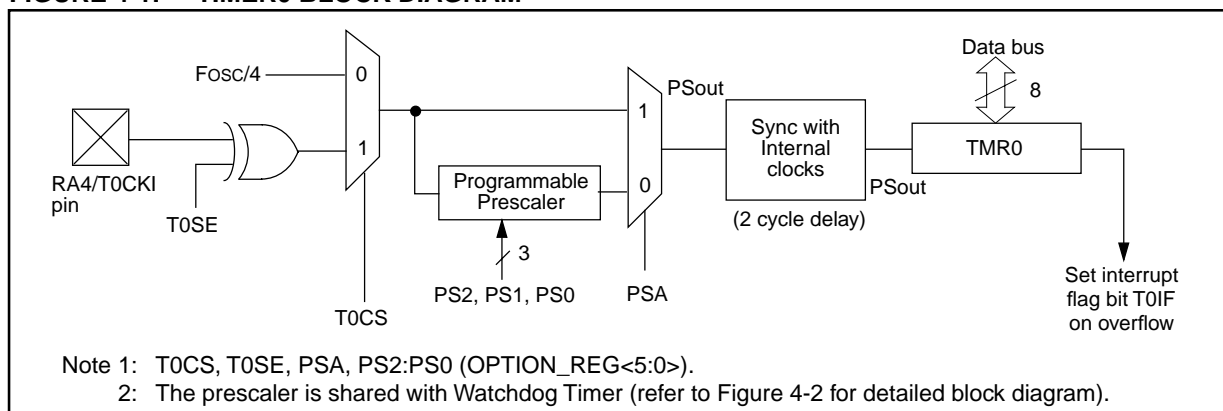

# PIC16C63A/65B/73B/74B

## 4.2.1 SWITCHING PRESCALER ASSIGNMENT

The prescaler assignment is fully under software control, i.e., it can be changed “on the fly” during program execution.

**Note:** To avoid an unintended device RESET, a specific instruction sequence (shown in the PICmicro™ Mid-Range Reference Manual, (DS33023). must be executed when changing the prescaler assignment from Timer0 to the WDT. This sequence must be followed even if the WDT is disabled.

## 4.3 Timer0 Interrupt

The TMR0 interrupt is generated when the TMR0 register overflows from FFh to 00h. This overflow sets bit T0IF (INTCON<2>). The interrupt can be masked by clearing bit T0IE (INTCON<5>). Bit T0IF must be cleared in software by the Timer0 module interrupt service routine before re-enabling this interrupt. The TMR0 interrupt cannot awaken the processor from SLEEP since the timer is shut off during SLEEP.

**FIGURE 4-2: BLOCK DIAGRAM OF THE TIMER0/WDT PRESCALER**

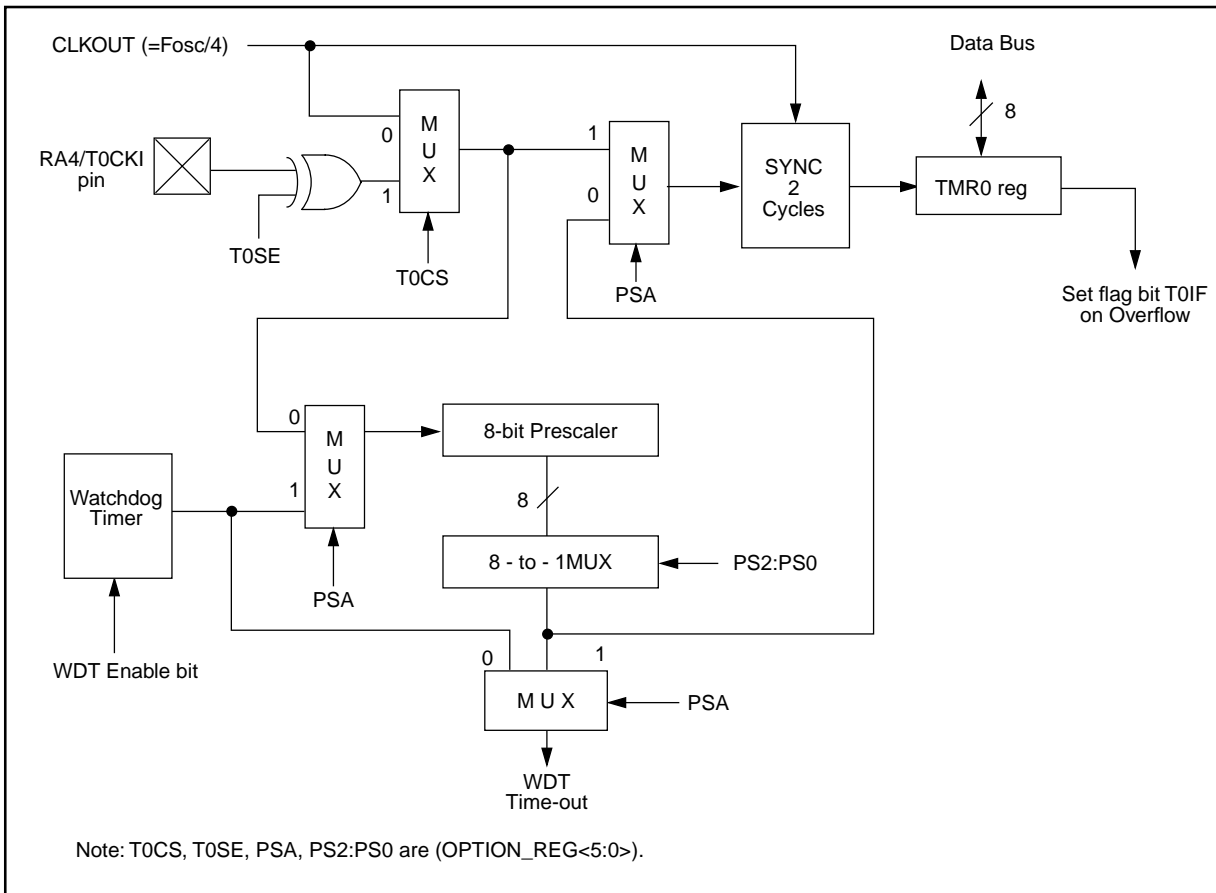

**TABLE 4-1: REGISTERS ASSOCIATED WITH TIMER0**

Address	Name	Bit 7	Bit 6	Bit 5	Bit 4	Bit 3	Bit 2	Bit 1	Bit 0	Value on POR, BOR	Value on all other resets
01h	TMR0	Timer0 module's register								xxxx xxxx	uuuu uuuu
0Bh, 8Bh	INTCON	GIE	PEIE	T0IE	INTE	RBIE	T0IF	INTF	RBIF	0000 000x	0000 000u
81h	OPTION_REG	RBPU	INTEDG	T0CS	T0SE	PSA	PS2	PS1	PS0	1111 1111	1111 1111
85h	TRISA	—	—	PORTA Data Direction Register						--11 1111	--11 1111

Legend: x = unknown, u = unchanged, - = unimplemented locations read as '0'. Shaded cells are not used by Timer0.

# PIC16C63A/65B/73B/74B

## 5.0 TIMER1 MODULE

The Timer1 module timer/counter has the following features:

- 16-bit timer/counter  
(Two 8-bit registers; TMR1H and TMR1L)
- Readable and writable (Both registers)
- Internal or external clock select
- Interrupt on overflow from FFFFh to 0000h
- Reset from CCP module trigger

Timer1 has a control register, shown in Figure 5-1. Timer1 can be enabled/disabled by setting/clearing control bit TMR1ON (T1CON<0>).

Figure 5-2 is a simplified block diagram of the Timer1 module.

Additional information on timer modules is available in the PICmicro™ Mid-Range Reference Manual, (DS33023).

## 5.1 Timer1 Operation

Timer1 can operate in one of these modes:

- As a timer
- As a synchronous counter
- As an asynchronous counter

The operating mode is determined by the clock select bit, TMR1CS (T1CON<1>).

In timer mode, Timer1 increments every instruction cycle. In counter mode, it increments on every rising edge of the external clock input.

When the Timer1 oscillator is enabled (T1OSCEN is set), the RC1/T1OSI and RC0/T1OSO/T1CKI pins become inputs. That is, the TRISC<1:0> value is ignored.

Timer1 also has an internal "reset input". This reset can be generated by the CCP module (Section 7.0).

**FIGURE 5-1: T1CON: TIMER1 CONTROL REGISTER (ADDRESS 10h)**

U-0	U-0	R/W-0	R/W-0	R/W-0	R/W-0	R/W-0	R/W-0	
—	—	T1CKPS1	T1CKPS0	T1OSCEN	T1SYN $\bar{C}$	TMR1CS	TMR1ON	
bit7								bit0

R = Readable bit  
W = Writable bit  
U = Unimplemented bit, read as '0'  
-n = Value at POR reset

bit 7-6: **Unimplemented:** Read as '0'

bit 5-4: **T1CKPS1:T1CKPS0:** Timer1 Input Clock Prescale Select bits  
11 = 1:8 Prescale value  
10 = 1:4 Prescale value  
01 = 1:2 Prescale value  
00 = 1:1 Prescale value

bit 3: **T1OSCEN:** Timer1 Oscillator Enable Control bit  
1 = Oscillator is enabled  
0 = Oscillator is shut off  
Note: The oscillator inverter and feedback resistor are turned off to eliminate power drain

bit 2: **T1SYN $\bar{C}$ :** Timer1 External Clock Input Synchronization Control bit

TMR1CS = 1  
1 = Do not synchronize external clock input  
0 = Synchronize external clock input

TMR1CS = 0  
This bit is ignored. Timer1 uses the internal clock when TMR1CS = 0.

bit 1: **TMR1CS:** Timer1 Clock Source Select bit  
1 = External clock from pin RC0/T1OSO/T1CKI (on the rising edge)  
0 = Internal clock (FOSC/4)

bit 0: **TMR1ON:** Timer1 On bit  
1 = Enables Timer1  
0 = Stops Timer1

# PIC16C63A/65B/73B/74B

FIGURE 5-2: TIMER1 BLOCK DIAGRAM

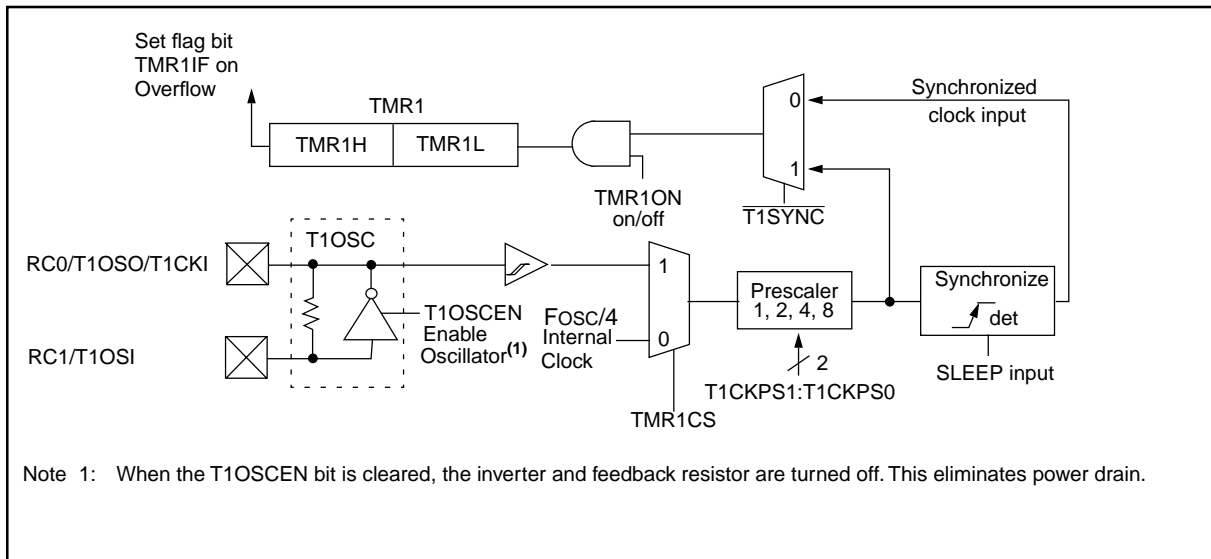



# PIC16C63A/65B/73B/74B

## 5.2 Timer1 Oscillator

A crystal oscillator circuit is built-in between pins T1OSI (input) and T1OSO (amplifier output). It is enabled by setting control bit T1OSCEN (T1CON<3>). The oscillator is a low power oscillator rated up to 200 kHz. It will continue to run during SLEEP. It is primarily intended for a 32 kHz crystal. Table 5-1 shows the capacitor selection for the Timer1 oscillator.

The Timer1 oscillator is identical to the LP oscillator. The user must provide a software time delay to ensure proper oscillator start-up.

**TABLE 5-1: CAPACITOR SELECTION FOR THE TIMER1 OSCILLATOR**

Osc Type	Freq	C1	C2
LP	32 kHz	33 pF	33 pF
	100 kHz	15 pF	15 pF
	200 kHz	15 pF	15 pF
<b>These values are for design guidance only.</b>			
<b>Crystals Tested:</b>			
32.768 kHz	Epson C-001R32.768K-A	± 20 PPM	
100 kHz	Epson C-2 100.00 KC-P	± 20 PPM	
200 kHz	STD XTL 200.000 kHz	± 20 PPM	
Note 1: Higher capacitance increases the stability of the oscillator but also increases the start-up time. 2: Since each resonator/crystal has its own characteristics, the user should consult the resonator/crystal manufacturer for appropriate values of external components.			

**TABLE 5-2: REGISTERS ASSOCIATED WITH TIMER1 AS A TIMER/COUNTER**

Address	Name	Bit 7	Bit 6	Bit 5	Bit 4	Bit 3	Bit 2	Bit 1	Bit 0	Value on POR, BOR	Value on all other resets
0Bh,8Bh	INTCON	GIE	PEIE	T0IE	INTE	RBIE	T0IF	INTF	RBIF	0000 000x	0000 000u
0Ch	PIR1	(1)	ADIF	(1)	(1)	SSPIF	CCP1IF	TMR2IF	TMR1IF	0000 0000	0000 0000
8Ch	PIE1	(1)	ADIE	(1)	(1)	SSPIE	CCP1IE	TMR2IE	TMR1IE	0000 0000	0000 0000
0Eh	TMR1L	Holding register for the Least Significant Byte of the 16-bit TMR1 register								xxxx xxxx	uuuu uuuu
0Fh	TMR1H	Holding register for the Most Significant Byte of the 16-bit TMR1 register								xxxx xxxx	uuuu uuuu
10h	T1CON	—	—	T1CKPS1	T1CKPS0	T1OSCEN	T1SYNC	TMR1CS	TMR1ON	--00 0000	--uu uuuu

Legend: x = unknown, u = unchanged, - = unimplemented read as '0'. Shaded cells are not used by the Timer1 module.

Note 1: These bits are reserved, maintain as '0'.

## 5.3 Timer1 Interrupt

The TMR1 Register pair (TMR1H:TMR1L) increments from 0000h to FFFFh and rolls over to 0000h. The TMR1 Interrupt, if enabled, is generated on overflow which is latched in interrupt flag bit TMR1IF (PIR1<0>). This interrupt can be enabled/disabled by setting/clearing TMR1 interrupt enable bit TMR1IE (PIE1<0>).

## 5.4 Resetting Timer1 using a CCP Trigger Output

If the CCP module is configured in compare mode to generate a "special event trigger" (CCP1M3:CCP1M0 = 1011), this signal will reset Timer1 and start an A/D conversion (if the A/D module is enabled).

**Note:** The special event triggers from the CCP1 module will not set interrupt flag bit TMR1IF (PIR1<0>).

Timer1 must be configured for either timer or synchronized counter mode to take advantage of this feature. If Timer1 is running in asynchronous counter mode, this reset operation may not work.

In the event that a write to Timer1 coincides with a special event trigger from CCP1, the write will take precedence.

In this mode of operation, the CCPR1H:CCPR1L registers pair effectively becomes the period register for Timer1.

# PIC16C63A/65B/73B/74B

---

NOTES:

# PIC16C63A/65B/73B/74B

## 6.0 TIMER2 MODULE

The Timer2 module timer has the following features:

- 8-bit timer (TMR2 register)
- 8-bit period register (PR2)
- Readable and writable (Both registers)
- Software programmable prescaler (1:1, 1:4, 1:16)
- Software programmable postscaler (1:1 to 1:16)
- Interrupt on TMR2 match of PR2
- SSP module optional use of TMR2 output to generate clock shift

Timer2 has a control register, shown in Figure 6-1. Timer2 can be shut off by clearing control bit TMR2ON (T2CON<2>) to minimize power consumption.

Figure 6-2 is a simplified block diagram of the Timer2 module.

Additional information on timer modules is available in the PICmicro™ Mid-Range Reference Manual, (DS33023).

## 6.1 Timer2 Operation

Timer2 can be used as the PWM time-base for PWM mode of the CCP module.

The TMR2 register is readable and writable, and is cleared on any device reset.

The input clock ( $F_{osc}/4$ ) has a prescale option of 1:1, 1:4 or 1:16, selected by control bits T2CKPS1:T2CKPS0 (T2CON<1:0>).

The match output of TMR2 goes through a 4-bit postscaler (which gives a 1:1 to 1:16 scaling inclusive) to generate a TMR2 interrupt (latched in flag bit TMR2IF, (PIR1<1>)).

The prescaler and postscaler counters are cleared when any of the following occurs:

- a write to the TMR2 register
- a write to the T2CON register
- any device reset (Power-on Reset,  $\overline{MCLR}$  reset, Watchdog Timer reset, or Brown-out Reset)

TMR2 is not cleared when T2CON is written.

**FIGURE 6-1: T2CON: TIMER2 CONTROL REGISTER (ADDRESS 12h)**

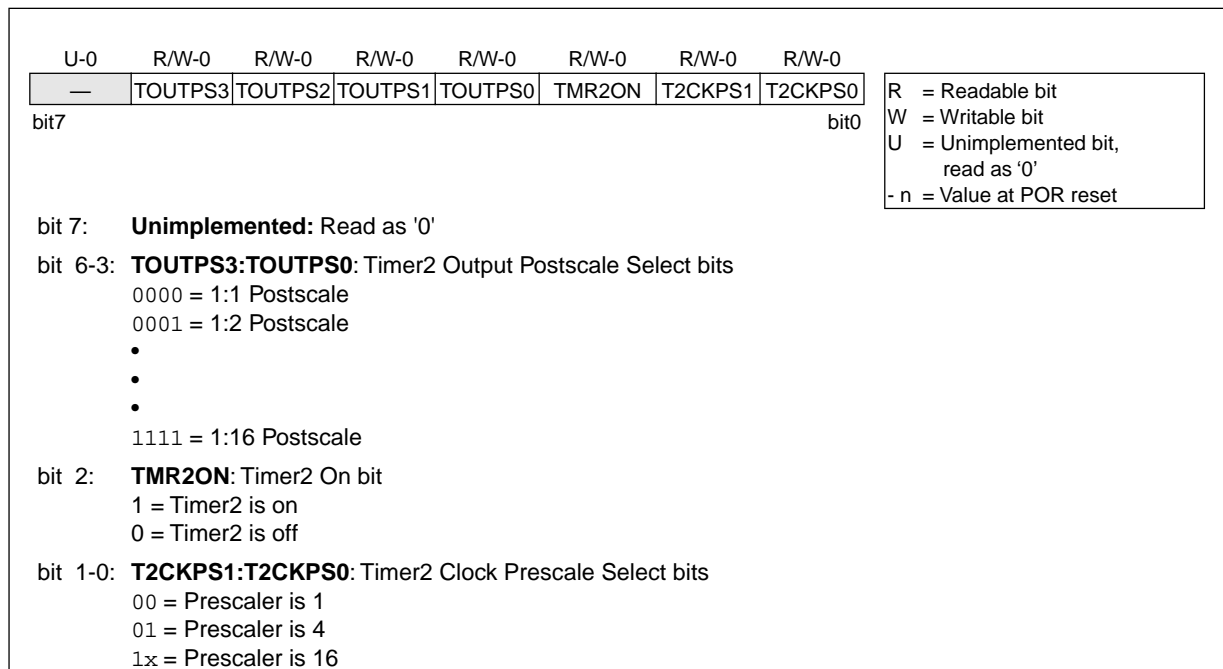

# PIC16C63A/65B/73B/74B

## 6.2 Timer2 Interrupt

The Timer2 module has an 8-bit period register PR2. Timer2 increments from 00h until it matches PR2 and then resets to 00h on the next increment cycle. PR2 is a readable and writable register. The PR2 register is initialized to FFh upon reset.

## 6.3 Output of TMR2

The output of TMR2 (before the postscaler) is fed to the Synchronous Serial Port module, which optionally uses it to generate shift clock.

FIGURE 6-2: TIMER2 BLOCK DIAGRAM

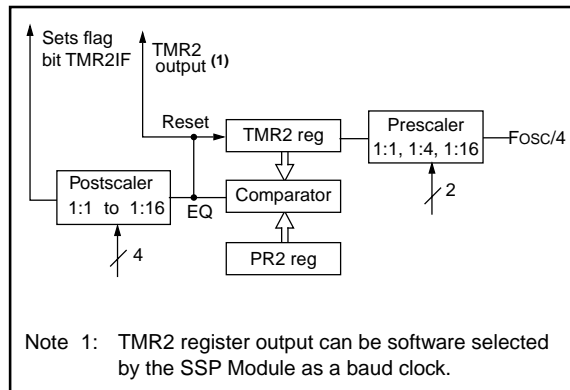

TABLE 6-1: REGISTERS ASSOCIATED WITH TIMER2 AS A TIMER/COUNTER

Address	Name	Bit 7	Bit 6	Bit 5	Bit 4	Bit 3	Bit 2	Bit 1	Bit 0	Value on: POR, BOR	Value on all other resets
0Bh,8Bh	INTCON	GIE	PEIE	TOIE	INTE	RBIE	TOIF	INTF	RBIF	0000 000x	0000 000u
0Ch	PIR1	(1)	ADIF	(1)	(1)	SSPIF	CCP1IF	TMR2IF	TMR1IF	0000 0000	0000 0000
8Ch	PIE1	(1)	ADIE	(1)	(1)	SSPIE	CCP1IE	TMR2IE	TMR1IE	0000 0000	0000 0000
11h	TMR2	Timer2 module's register								0000 0000	0000 0000
12h	T2CON	—	TOUTPS3	TOUTPS2	TOUTPS1	TOUTPS0	TMR2ON	T2CKPS1	T2CKPS0	-000 0000	-000 0000
92h	PR2	Timer2 Period Register								1111 1111	1111 1111

Legend: x = unknown, u = unchanged, - = unimplemented read as '0'. Shaded cells are not used by the Timer2 module.

Note 1: These bits are reserved, maintain as '0'.

# PIC16C63A/65B/73B/74B

## 7.0 CAPTURE/COMPARE/PWM (CCP) MODULE(S)

Each CCP (Capture/Compare/PWM) module contains a 16-bit register which can operate as a 16-bit capture register, as a 16-bit compare register or as a PWM master/slave Duty Cycle register. Table 7-1 shows the timer resources of the CCP module modes.

The operation of CCP1 is identical to that of CCP2, with the exception of the special trigger. Therefore, operation of a CCP module in the following sections is described with respect to CCP1.

Table 7-2 shows the interaction of the CCP modules.

### CCP1 Module

Capture/Compare/PWM Register1 (CCPR1) is comprised of two 8-bit registers: CCPR1L (low byte) and CCPR1H (high byte). The CCP1CON register controls the operation of CCP1. All are readable and writable.

**TABLE 7-2: INTERACTION OF TWO CCP MODULES**

CCPx Mode	CCPy Mode	Interaction
Capture	Capture	Same TMR1 time-base.
Capture	Compare	The compare should be configured for the special event trigger, which clears TMR1.
Compare	Compare	The compare(s) should be configured for the special event trigger, which clears TMR1.
PWM	PWM	The PWMs will have the same frequency, and update rate (TMR2 interrupt).
PWM	Capture	None
PWM	Compare	None

### CCP2 Module

Capture/Compare/PWM Register2 (CCPR2) is comprised of two 8-bit registers: CCPR2L (low byte) and CCPR2H (high byte). The CCP2CON register controls the operation of CCP2. All are readable and writable.

Additional information on the CCP module is available in the PICmicro™ Mid-Range Reference Manual, (DS33023).

**TABLE 7-1: CCP MODE - TIMER RESOURCE**

CCP Mode	Timer Resource
Capture	Timer1
Compare	Timer1
PWM	Timer2

**FIGURE 7-1: CCP1CON REGISTER (ADDRESS 17h) / CCP2CON REGISTER (ADDRESS 1Dh)**

U-0	U-0	R/W-0	R/W-0	R/W-0	R/W-0	R/W-0	R/W-0	
—	—	CCPxX	CCPxY	CCPxM3	CCPxM2	CCPxM1	CCPxM0	
bit7								bit0

R = Readable bit  
W = Writable bit  
U = Unimplemented bit, read as '0'  
- n = Value at POR reset

bit 7-6: **Unimplemented:** Read as '0'

bit 5-4: **CCPxX:CCPxY:** PWM Least Significant bits  
Capture Mode: Unused  
Compare Mode: Unused  
PWM Mode: These bits are the two LSbs of the PWM duty cycle. The eight MSbs are found in CCPRxL.

bit 3-0: **CCPxM3:CCPxM0:** CCPx Mode Select bits  
0000 = Capture/Compare/PWM off (resets CCPx module)  
0100 = Capture mode, every falling edge  
0101 = Capture mode, every rising edge  
0110 = Capture mode, every 4th rising edge  
0111 = Capture mode, every 16th rising edge  
1000 = Compare mode, set output on match (CCPxIF bit is set)  
1001 = Compare mode, clear output on match (CCPxIF bit is set)  
1010 = Compare mode, generate software interrupt on match (CCPxIF bit is set, CCPx pin is unaffected)  
1011 = Compare mode, trigger special event (CCPxIF bit is set; CCP1 resets TMR1; CCP2 resets TMR1 and starts an A/D conversion (if A/D module is enabled))  
11:xx = PWM mode

# PIC16C63A/65B/73B/74B

## 7.1 Capture Mode

In Capture mode, CCP1H:CCP1L captures the 16-bit value of the TMR1 register when an event occurs on pin RC2/CCP1. An event is defined as:

- every falling edge
- every rising edge
- every 4th rising edge
- every 16th rising edge

An event is selected by control bits CCP1M3:CCP1M0 (CCP1CON<3:0>). When a capture is made, the interrupt request flag bit CCP1IF (PIR1<2>) is set. It must be cleared in software. If another capture occurs before the value in register CCP1R1 is read, the old captured value will be lost.

### 7.1.1 CCP PIN CONFIGURATION

In Capture mode, the RC2/CCP1 pin should be configured as an input by setting the TRISC<2> bit.

**Note:** If the RC2/CCP1 is configured as an output, a write to the port can cause a capture condition.

**FIGURE 7-2: CAPTURE MODE OPERATION BLOCK DIAGRAM**

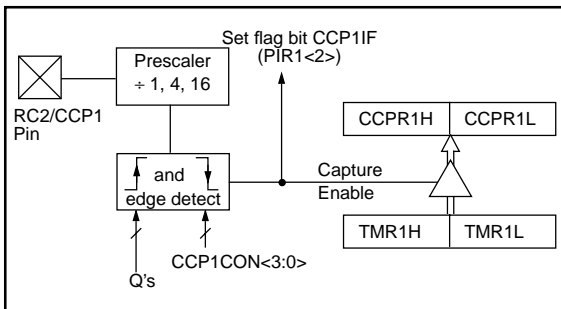

### 7.1.2 TIMER1 MODE SELECTION

Timer1 must be running in timer mode or synchronized counter mode for the CCP module to use the capture feature. In asynchronous counter mode, the capture operation may not work.

### 7.1.3 SOFTWARE INTERRUPT

When the Capture mode is changed, a false capture interrupt may be generated. The user should keep bit CCP1IE (PIE1<2>) clear to avoid false interrupts and should clear the flag bit CCP1IF following any such change in operating mode.

### 7.1.4 CCP PRESCALER

There are four prescaler settings, specified by bits CCP1M3:CCP1M0. Whenever the CCP module is turned off, or the CCP module is not in capture mode, the prescaler counter is cleared. This means that any reset will clear the prescaler counter.

Switching from one capture prescaler to another may generate an interrupt. Also, the prescaler counter will not be cleared, therefore the first capture may be from a non-zero prescaler. Example 7-1 shows the recommended method for switching between capture prescalers. This example also clears the prescaler counter and will not generate the "false" interrupt.

**EXAMPLE 7-1: CHANGING BETWEEN CAPTURE PRESCALERS**

```

CLRf  CCP1CON      ;Turn CCP module off
MOVLW NEW_CAPT_PS ;Load the W reg with
                ; the new prescaler
                ; mode value and CCP ON
MOVWF  CCP1CON     ;Load CCP1CON with this
                ; value
    
```

# PIC16C63A/65B/73B/74B

## 7.2 Compare Mode

In Compare mode, the 16-bit CCPR1 register value is constantly compared against the TMR1 register pair value. When a match occurs, the RC2/CCP1 pin is:

- driven High
- driven Low
- remains Unchanged

The action on the pin is based on the value of control bits CCP1M3:CCP1M0 (CCP1CON<3:0>). At the same time, interrupt flag bit CCP1IF is set.

**FIGURE 7-3: COMPARE MODE OPERATION BLOCK DIAGRAM**

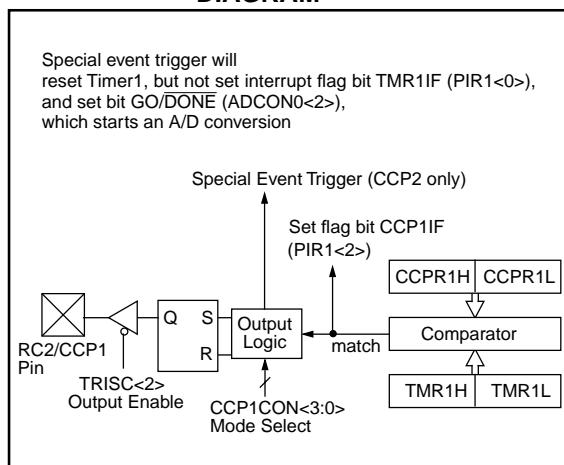

### 7.2.1 CCP PIN CONFIGURATION

The user must configure the RC2/CCP1 pin as an output by clearing the TRISC<2> bit.

**Note:** Clearing the CCP1CON register will force the RC2/CCP1 compare output latch to the default low level. This is not the data latch.

### 7.2.2 TIMER1 MODE SELECTION

Timer1 must be running in Timer mode or Synchronized Counter mode if the CCP module is using the compare feature. In Asynchronous Counter mode, the compare operation may not work.

### 7.2.3 SOFTWARE INTERRUPT MODE

When generate software interrupt is chosen the CCP1 pin is not affected. Only a CCP interrupt is generated (if enabled).

### 7.2.4 SPECIAL EVENT TRIGGER

In this mode, an internal hardware trigger is generated which may be used to initiate an action.

The special event trigger output of CCP1 resets the TMR1 register pair. This allows the CCPR1 register to effectively be a 16-bit programmable period register for Timer1.

The special trigger output of CCP2 resets the TMR1 register pair, and starts an A/D conversion (if the A/D module is enabled).

**Note:** The special event trigger from the CCP2 module will not set interrupt flag bit TMR1IF (PIR1<0>).

**TABLE 7-3: REGISTERS ASSOCIATED WITH CAPTURE, COMPARE, AND TIMER1**

Address	Name	Bit 7	Bit 6	Bit 5	Bit 4	Bit 3	Bit 2	Bit 1	Bit 0	Value on POR, BOR	Value on all other resets
0Bh,8Bh	INTCON	GIE	PEIE	TOIE	INTE	RBIE	TOIF	INTF	RBIF	0000 000x	0000 000u
0Ch	PIR1	(1)	ADIF	(1)	(1)	SSPIF	CCP1IF	TMR2IF	TMR1IF	0000 0000	0000 0000
8Ch	PIE1	(1)	ADIE	(1)	(1)	SSPIE	CCP1IE	TMR2IE	TMR1IE	0000 0000	0000 0000
87h	TRISC	PORTC Data Direction Register								1111 1111	1111 1111
0Eh	TMR1L	Holding register for the Least Significant Byte of the 16-bit TMR1 register								xxxx xxxx	uuuu uuuu
0Fh	TMR1H	Holding register for the Most Significant Byte of the 16-bit TMR1 register								xxxx xxxx	uuuu uuuu
10h	T1CON	—	—	T1CKPS1	T1CKPS0	T1OSCEN	T1SYN $\bar{C}$	TMR1CS	TMR1ON	--00 0000	--uu uuuu
15h	CCPR1L	Capture/Compare/PWM register1 (LSB)								xxxx xxxx	uuuu uuuu
16h	CCPR1H	Capture/Compare/PWM register1 (MSB)								xxxx xxxx	uuuu uuuu
17h	CCP1CON	—	—	CCP1X	CCP1Y	CCP1M3	CCP1M2	CCP1M1	CCP1M0	--00 0000	--00 0000

Legend: x = unknown, u = unchanged, - = unimplemented read as '0'. Shaded cells are not used by Capture and Timer1.

Note 1: These bits/registers are reserved, maintain as '0'.

# PIC16C63A/65B/73B/74B

## 7.3 PWM Mode

In Pulse Width Modulation (PWM) mode, the CCP1 pin produces up to a 10-bit resolution PWM output. Since the CCP1 pin is multiplexed with the PORTC data latch, the TRISC<2> bit must be cleared to make the CCP1 pin an output.

**Note:** Clearing the CCP1CON register will force the CCP1 PWM output latch to the default low level. This is not the PORTC I/O data latch.

Figure 7-4 shows a simplified block diagram of the CCP module in PWM mode.

For a step by step procedure on how to set up the CCP module for PWM operation, see Section 7.3.3.

**FIGURE 7-4: SIMPLIFIED PWM BLOCK DIAGRAM**

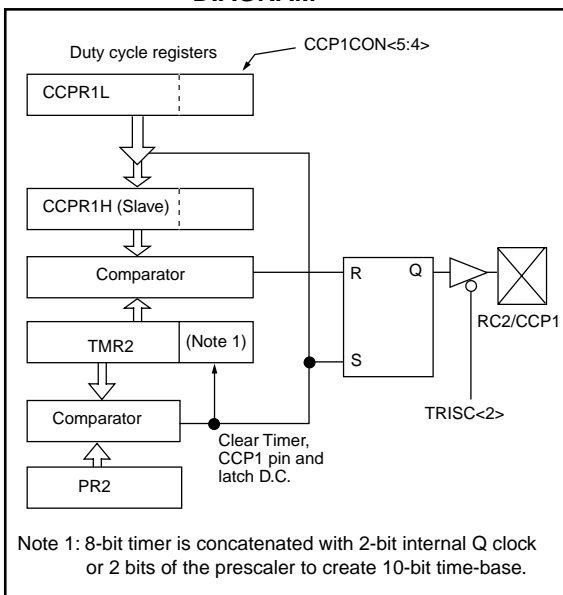

A PWM output (Figure 7-5) has a time base (period) and a time that the output stays high (duty cycle). The frequency of the PWM is the inverse of the period (1/period).

**FIGURE 7-5: PWM OUTPUT**

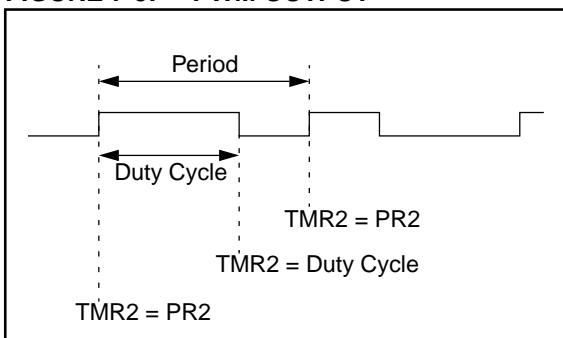

### 7.3.1 PWM PERIOD

The PWM period is specified by writing to the PR2 register. The PWM period can be calculated using the following formula:

$$\text{PWM period} = [(PR2) + 1] \cdot 4 \cdot T_{osc} \cdot (\text{TMR2 prescale value})$$

PWM frequency is defined as  $1 / [\text{PWM period}]$ .

When TMR2 is equal to PR2, the following three events occur on the next increment cycle:

- TMR2 is cleared
- The CCP1 pin is set (exception: if PWM duty cycle = 0%, the CCP1 pin will not be set)
- The PWM duty cycle is latched from CCPR1L into CCPR1H

**Note:** The Timer2 postscaler (see Section 6.0) is not used in the determination of the PWM frequency. The postscaler could be used to have a servo update rate at a different frequency than the PWM output.

### 7.3.2 PWM DUTY CYCLE

The PWM duty cycle is specified by writing to the CCPR1L register and to the CCP1CON<5:4> bits. Up to 10-bit resolution is available: the CCPR1L contains the eight MSBs and the CCP1CON<5:4> contains the two LSBs. This 10-bit value is represented by CCPR1L:CCP1CON<5:4>. The following equation is used to calculate the PWM duty cycle in time:

$$\text{PWM DUTY CYCLE} = (\text{CCPR1L:CCP1CON<5:4>}) \cdot T_{osc} \cdot (\text{TMR2 PRESCALE VALUE})$$

CCPR1L and CCP1CON<5:4> can be written to at any time, but the duty cycle value is not latched into CCPR1H until after a match between PR2 and TMR2 occurs (i.e., the period is complete). In PWM mode, CCPR1H is a read-only register.

The CCPR1H register and a 2-bit internal latch are used to double buffer the PWM duty cycle. This double buffering is essential for glitchless PWM operation.

When the CCPR1H and 2-bit latch match TMR2 concatenated with an internal 2-bit Q clock or 2 bits of the TMR2 prescaler, the CCP1 pin is cleared.

Maximum PWM resolution (bits) for a given PWM frequency:

$$= \frac{\log\left(\frac{F_{osc}}{F_{PWM}}\right)}{\log(2)} \text{ bits}$$

**Note:** If the PWM duty cycle value is longer than the PWM period, the CCP1 pin will not be cleared.

For an example PWM period and duty cycle calculation, see the PICmicro™ Mid-Range Reference Manual (DS33023).



# PIC16C63A/65B/73B/74B

## 7.3.3 SET-UP FOR PWM OPERATION

The following steps should be taken when configuring the CCP module for PWM operation:

1. Set the PWM period by writing to the PR2 register.
2. Set the PWM duty cycle by writing to the CCPR1L register and CCP1CON<5:4> bits.
3. Make the CCP1 pin an output by clearing the TRISC<2> bit.
4. Set the TMR2 prescale value and enable Timer2 by writing to T2CON.
5. Configure the CCP1 module for PWM operation.

**TABLE 7-4: EXAMPLE PWM FREQUENCIES AND RESOLUTIONS AT 20 MHz**

PWM Frequency	1.22 kHz	4.88 kHz	19.53 kHz	78.12 kHz	156.3 kHz	208.3 kHz
Timer Prescaler (1, 4, 16)	16	4	1	1	1	1
PR2 Value	0xFF	0xFF	0xFF	0x3F	0x1F	0x17
Maximum Resolution (bits)	10	10	10	8	7	5.5

**TABLE 7-5: REGISTERS ASSOCIATED WITH PWM AND TIMER2**

Address	Name	Bit 7	Bit 6	Bit 5	Bit 4	Bit 3	Bit 2	Bit 1	Bit 0	Value on POR, BOR	Value on all other resets
0Bh,8Bh	INTCON	GIE	PEIE	T0IE	INTE	RBIE	T0IF	INTF	RBIF	0000 000x	0000 000u
0Ch	PIR1	(1)	ADIF	(1)	(1)	SSPIF	CCP1IF	TMR2IF	TMR1IF	0000 0000	0000 0000
8Ch	PIE1	(1)	ADIE	(1)	(1)	SSPIE	CCP1IE	TMR2IE	TMR1IE	0000 0000	0000 0000
87h	TRISC	PORTC Data Direction Register								1111 1111	1111 1111
11h	TMR2	Timer2 module's register								0000 0000	0000 0000
92h	PR2	Timer2 module's period register								1111 1111	1111 1111
12h	T2CON	—	TOUTPS3	TOUTPS2	TOUTPS1	TOUTPS0	TMR2ON	T2CKPS1	T2CKPS0	-000 0000	-000 0000
15h	CCPR1L	Capture/Compare/PWM register1 (LSB)								xxxx xxxx	uuuu uuuu
16h	CCPR1H	Capture/Compare/PWM register1 (MSB)								xxxx xxxx	uuuu uuuu
17h	CCP1CON	—	—	CCP1X	CCP1Y	CCP1M3	CCP1M2	CCP1M1	CCP1M0	--00 0000	--00 0000

Legend: x = unknown, u = unchanged, - = unimplemented read as '0'. Shaded cells are not used by PWM and Timer2.

Note 1: These bits/registers are reserved, maintain as '0'.

# PIC16C63A/65B/73B/74B

---

NOTES:

## 8.0 SYNCHRONOUS SERIAL PORT (SSP) MODULE

### 8.1 SSP Module Overview

The Synchronous Serial Port (SSP) module is a serial interface useful for communicating with other peripheral or microcontroller devices. These peripheral devices may be Serial EEPROMs, shift registers, display drivers, A/D converters, etc. The SSP module can operate in one of two modes:

- Serial Peripheral Interface (SPI)
- Inter-Integrated Circuit (I<sup>2</sup>C)

For more information on SSP operation (including an I<sup>2</sup>C Overview), refer to the PICmicro™ Mid-Range Reference Manual (DS33023). Also, refer to Application Note AN578, *“Use of the SSP Module in the I<sup>2</sup>C Multi-Master Environment.”*

# PIC16C63A/65B/73B/74B

**FIGURE 8-1: SSPSTAT: SYNC SERIAL PORT STATUS REGISTER (ADDRESS 94h)**

R/W-0	R/W-0	R-0	R-0	R-0	R-0	R-0	R-0
SMP	CKE	D/ $\bar{A}$	P	S	R/ $\bar{W}$	UA	BF
bit7							bit0

R = Readable bit  
W = Writable bit  
U = Unimplemented bit, read as '0'  
- n = Value at POR reset

bit 7: **SMP**: SPI data input sample phase  
SPI Master Operation  
1 = Input data sampled at end of data output time  
0 = Input data sampled at middle of data output time  
SPI Slave Mode  
SMP must be cleared when SPI is used in slave mode

bit 6: **CKE**: SPI Clock Edge Select  
CKP = 0  
1 = Data transmitted on rising edge of SCK  
0 = Data transmitted on falling edge of SCK  
CKP = 1  
1 = Data transmitted on falling edge of SCK  
0 = Data transmitted on rising edge of SCK

bit 5: **D/ $\bar{A}$** : Data/Address bit (I<sup>2</sup>C mode only)  
1 = Indicates that the last byte received or transmitted was data  
0 = Indicates that the last byte received or transmitted was address

bit 4: **P**: Stop bit (I<sup>2</sup>C mode only. This bit is cleared when the SSP module is disabled, or when the Start bit is detected last, SSPEN is cleared)  
1 = Indicates that a stop bit has been detected last (this bit is '0' on RESET)  
0 = Stop bit was not detected last

bit 3: **S**: Start bit (I<sup>2</sup>C mode only. This bit is cleared when the SSP module is disabled, or when the Stop bit is detected last, SSPEN is cleared)  
1 = Indicates that a start bit has been detected last (this bit is '0' on RESET)  
0 = Start bit was not detected last

bit 2: **R/ $\bar{W}$** : Read/Write bit information (I<sup>2</sup>C mode only)  
This bit holds the R/W bit information following the last address match. This bit is only valid from the address match to the next start bit, stop bit, or  $\bar{A}CK$  bit.  
1 = Read  
0 = Write

bit 1: **UA**: Update Address (10-bit I<sup>2</sup>C mode only)  
1 = Indicates that the user needs to update the address in the SSPADD register  
0 = Address does not need to be updated

bit 0: **BF**: Buffer Full Status bit  
Receive (SPI and I<sup>2</sup>C modes)  
1 = Receive complete, SSPBUF is full  
0 = Receive not complete, SSPBUF is empty  
Transmit (I<sup>2</sup>C mode only)  
1 = Transmit in progress, SSPBUF is full  
0 = Transmit complete, SSPBUF is empty

# PIC16C63A/65B/73B/74B

**FIGURE 8-2: SSPCON: SYNC SERIAL PORT CONTROL REGISTER (ADDRESS 14h)**

R/W-0	R/W-0	R/W-0	R/W-0	R/W-0	R/W-0	R/W-0	R/W-0
WCOL	SSPOV	SSPEN	CKP	SSPM3	SSPM2	SSPM1	SSPM0
bit7							bit0

R = Readable bit  
W = Writable bit  
U = Unimplemented bit, read as '0'  
- n = Value at POR reset

bit 7: **WCOL**: Write Collision Detect bit  
1 = The SSPBUF register is written while it is still transmitting the previous word (must be cleared in software)  
0 = No collision

bit 6: **SSPOV**: Receive Overflow Indicator bit  
In SPI mode  
1 = A new byte is received while the SSPBUF register is still holding the previous data. In case of overflow, the data in SSPSR is lost. Overflow can only occur in slave mode. The user must read the SSPBUF, even if only transmitting data, to avoid setting overflow. In master operation, the overflow bit is not set since each new reception (and transmission) is initiated by writing to the SSPBUF register.  
0 = No overflow  
In I<sup>2</sup>C mode  
1 = A byte is received while the SSPBUF register is still holding the previous byte. SSPOV is a "don't care" in transmit mode. SSPOV must be cleared in software in either mode.  
0 = No overflow

bit 5: **SSPEN**: Synchronous Serial Port Enable bit  
In SPI mode  
1 = Enables serial port and configures SCK, SDO, and SDI as serial port pins  
0 = Disables serial port and configures these pins as I/O port pins  
In I<sup>2</sup>C mode  
1 = Enables the serial port and configures the SDA and SCL pins as serial port pins  
0 = Disables serial port and configures these pins as I/O port pins  
In both modes, when enabled, these pins must be properly configured as input or output.

bit 4: **CKP**: Clock Polarity Select bit  
In SPI mode  
1 = Idle state for clock is a high level  
0 = Idle state for clock is a low level  
In I<sup>2</sup>C mode  
SCK release control  
1 = Enable clock  
0 = Holds clock low (clock stretch) (Used to ensure data setup time)

bit 3-0: **SSPM3:SSPM0**: Synchronous Serial Port Mode Select bits  
0000 = SPI master operation, clock = Fosc/4  
0001 = SPI master operation, clock = Fosc/16  
0010 = SPI master operation, clock = Fosc/64  
0011 = SPI master operation, clock = TMR2 output/2  
0100 = SPI slave mode, clock = SCK pin.  $\overline{SS}$  pin control enabled.  
0101 = SPI slave mode, clock = SCK pin.  $\overline{SS}$  pin control disabled.  $\overline{SS}$  can be used as I/O pin  
0110 = I<sup>2</sup>C slave mode, 7-bit address  
0111 = I<sup>2</sup>C slave mode, 10-bit address  
1011 = I<sup>2</sup>C firmware controlled master operation (slave idle)  
1110 = I<sup>2</sup>C slave mode, 7-bit address with start and stop bit interrupts enabled  
1111 = I<sup>2</sup>C slave mode, 10-bit address with start and stop bit interrupts enabled

# PIC16C63A/65B/73B/74B

## 8.2 SPI Mode

This section contains register definitions and operational characteristics of the SPI module.

Additional information on SPI operation may be found in the PICmicro™ Mid-Range Reference Manual (DS33023).

### 8.2.1 OPERATION OF SSP MODULE IN SPI MODE

A block diagram of the SSP Module in SPI Mode is shown in Figure 8-3.

The SPI mode allows 8-bits of data to be synchronously transmitted and received simultaneously. To accomplish communication, typically three pins are used:

- Serial Data Out (SDO) RC5/SDO
- Serial Data In (SDI) RC4/SDI/SDA
- Serial Clock (SCK) RC3/SCK/SCL

Additionally a fourth pin may be used when in a slave mode of operation:

- Slave Select ( $\overline{SS}$ ) RA5/ $\overline{SS}$ /AN4

When initializing the SPI, several options need to be specified. This is done by programming the appropriate control bits in the SSPCON register (SSPCON<5:0>) and SSPSTAT<7:6>. These control bits allow the following to be specified:

- Master Operation (SCK is the clock output)
- Slave Mode (SCK is the clock input)
- Clock Polarity (Idle state of SCK)
- Clock Edge (Output data on rising/falling edge of SCK)
- Clock Rate (master operation only)
- Slave Select Mode (Slave mode only)

To enable the serial port, SSP Enable bit, SSPEN (SSPCON<5>) must be set. To reset or reconfigure SPI mode, clear bit SSPEN, re-initialize the SSPCON register and then set bit SSPEN. This configures the SDI, SDO, SCK and  $\overline{SS}$  pins as serial port pins. For the pins to behave as the serial port function, they must have their data direction bits (in the TRISC register) appropriately programmed. That is:

- SDI must have TRISC<4> set
- SDO must have TRISC<5> cleared
- SCK (master operation) must have TRISC<3> cleared
- SCK (Slave mode) must have TRISC<3> set
- $\overline{SS}$  must have TRISA<5> set

**Note:** When the SPI is in Slave Mode with  $\overline{SS}$  pin control enabled, (SSPCON<3:0> = 0100) the SPI module will reset if the  $\overline{SS}$  pin is set to VDD.

**Note:** If the SPI is used in Slave Mode with CKE = '1', then the  $\overline{SS}$  pin control must be enabled.

**FIGURE 8-3: SSP BLOCK DIAGRAM (SPI MODE)**

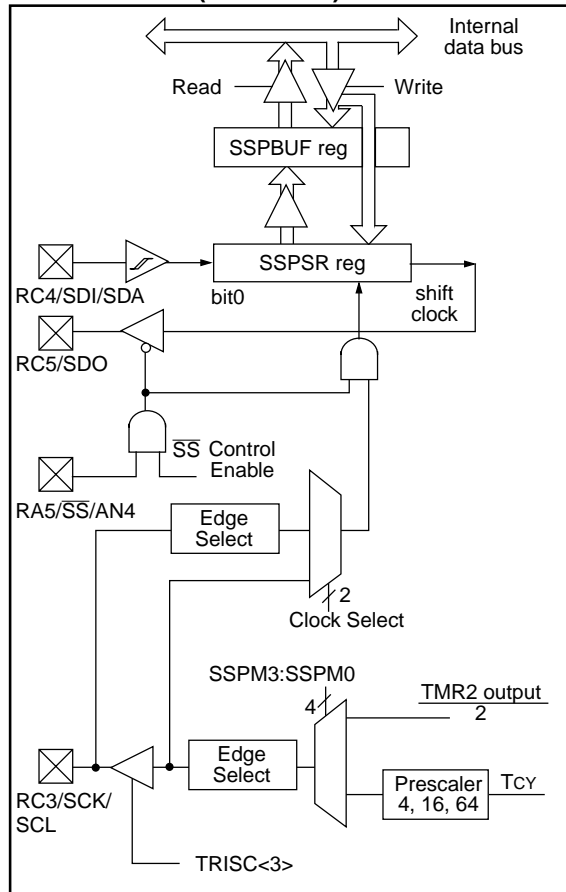

# PIC16C63A/65B/73B/74B

**TABLE 8-1: REGISTERS ASSOCIATED WITH SPI OPERATION**

Address	Name	Bit 7	Bit 6	Bit 5	Bit 4	Bit 3	Bit 2	Bit 1	Bit 0	Value on: POR, BOR	Value on all other resets
0Bh,8Bh	INTCON	GIE	PEIE	TOIE	INTE	RBIE	TOIF	INTF	RBIF	0000 000x	0000 000u
0Ch	PIR1	(1)	ADIF	(1)	(1)	SSPIF	CCP1IF	TMR2IF	TMR1IF	0000 0000	0000 0000
8Ch	PIE1	(1)	ADIE	(1)	(1)	SSPIE	CCP1IE	TMR2IE	TMR1IE	0000 0000	0000 0000
87h	TRISC	PORTC Data Direction Register								1111 1111	1111 1111
13h	SSPBUF	Synchronous Serial Port Receive Buffer/Transmit Register								xxxx xxxx	uuuu uuuu
14h	SSPCON	WCOL	SSPOV	SSPEN	CKP	SSPM3	SSPM2	SSPM1	SSPM0	0000 0000	0000 0000
85h	TRISA	—	—	PORTA Data Direction Register						--11 1111	--11 1111
94h	SSPSTAT	SMP	CKE	D/ $\bar{A}$	P	S	R/ $\bar{W}$	UA	BF	0000 0000	0000 0000

Legend: x = unknown, u = unchanged, - = unimplemented read as '0'. Shaded cells are not used by the SSP in SPI mode.

Note 1: Always maintain these bits clear.

# PIC16C63A/65B/73B/74B

## 8.3 SSP I<sup>2</sup>C Operation

The SSP module in I<sup>2</sup>C mode fully implements all slave functions, except general call support, and provides interrupts on start and stop bits in hardware to facilitate firmware implementations of the master functions. The SSP module implements the standard mode specifications as well as 7-bit and 10-bit addressing.

Two pins are used for data transfer. These are the RC3/SCK/SCL pin, which is the clock (SCL), and the RC4/SDI/SDA pin, which is the data (SDA). The user must configure these pins as inputs or outputs through the TRISC<4:3> bits.

The SSP module functions are enabled by setting SSP Enable bit SSPEN (SSPCON<5>).

**FIGURE 8-4: SSP BLOCK DIAGRAM (I<sup>2</sup>C MODE)**

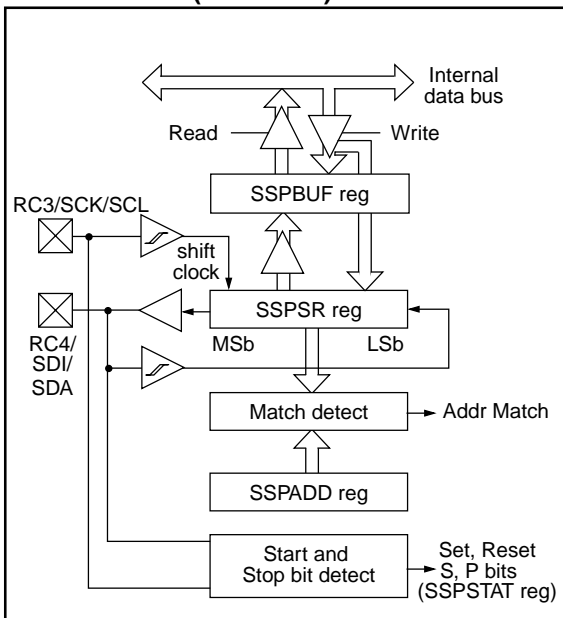

The SSP module has five registers for I<sup>2</sup>C operation. These are the:

- SSP Control Register (SSPCON)
- SSP Status Register (SSPSTAT)
- Serial Receive/Transmit Buffer (SSPBUF)
- SSP Shift Register (SSPSR) - Not directly accessible
- SSP Address Register (SSPADD)

The SSPCON register allows control of the I<sup>2</sup>C operation. Four mode selection bits (SSPCON<3:0>) allow one of the following I<sup>2</sup>C modes to be selected:

- I<sup>2</sup>C Slave mode (7-bit address)
- I<sup>2</sup>C Slave mode (10-bit address)
- I<sup>2</sup>C Slave mode (7-bit address), with start and stop bit interrupts enabled
- I<sup>2</sup>C Slave mode (10-bit address), with start and stop bit interrupts enabled
- I<sup>2</sup>C Firmware controlled master operation, slave is idle

Selection of any I<sup>2</sup>C mode, with the SSPEN bit set, forces the SCL and SDA pins to be open drain, provided these pins are programmed to inputs by setting the appropriate TRISC bits.

Additional information on SSP I<sup>2</sup>C operation may be found in the PICMicro™ Mid-Range Reference Manual (DS33023).

### 8.3.1 SLAVE MODE

In slave mode, the SCL and SDA pins must be configured as inputs (TRISC<4:3> set). The SSP module will override the input state with the output data when required (slave-transmitter).

When an address is matched or the data transfer after an address match is received, the hardware automatically will generate the acknowledge (ACK) pulse, and then load the SSPBUF register with the received value currently in the SSPSR register.

There are certain conditions that will cause the SSP module not to give this  $\overline{ACK}$  pulse. These are if either (or both):

- The buffer full bit BF (SSPSTAT<0>) was set before the transfer was received.
- The overflow bit SSPOV (SSPCON<6>) was set before the transfer was received.

In this case, the SSPSR register value is not loaded into the SSPBUF, but bit SSPIF (PIR1<3>) is set. Table 8-2 shows what happens when a data transfer byte is received, given the status of bits BF and SSPOV. The shaded cells show the condition where user software did not properly clear the overflow condition. Flag bit BF is cleared by reading the SSPBUF register while bit SSPOV is cleared through software.

The SCL clock input must have a minimum high and low for proper operation. The high and low times of the I<sup>2</sup>C specification as well as the requirement of the SSP module is shown in timing parameter #100 and parameter #101.



# PIC16C63A/65B/73B/74B

## 8.3.1.1 ADDRESSING

Once the SSP module has been enabled, it waits for a START condition to occur. Following the START condition, the 8-bits are shifted into the SSPSR register. All incoming bits are sampled with the rising edge of the clock (SCL) line. The value of register SSPSR<7:1> is compared to the value of the SSPADD register. The address is compared on the falling edge of the eighth clock (SCL) pulse. If the addresses match, and the BF and SSPOV bits are clear, the following events occur:

- The SSPSR register value is loaded into the SSPBUF register.
- The buffer full bit, BF is set.
- An  $\overline{ACK}$  pulse is generated.
- SSP interrupt flag bit, SSPIF (PIR1<3>) is set (interrupt is generated if enabled) - on the falling edge of the ninth SCL pulse.

In 10-bit address mode, two address bytes need to be received by the slave. The five Most Significant bits (MSBs) of the first address byte specify if this is a 10-bit address. Bit R/W (SSPSTAT<2>) must specify a write so the slave device will receive the second address byte. For a 10-bit address the first byte would equal

'1111 0 A9 A8 0', where A9 and A8 are the two MSBs of the address. The sequence of events for 10-bit address is as follows with steps 7- 9 for slave-transmitter:

- Receive first (high) byte of Address (bits SSPIF, BF, and bit UA (SSPSTAT<1>) are set).
- Update the SSPADD register with second (low) byte of Address (clears bit UA and releases the SCL line).
- Read the SSPBUF register (clears bit BF) and clear flag bit SSPIF.
- Receive second (low) byte of Address (bits SSPIF, BF, and UA are set).
- Update the SSPADD register with the first (high) byte of Address. If match releases SCL line, this will clear bit UA.
- Read the SSPBUF register (clears bit BF) and clear flag bit SSPIF.
- Receive repeated START condition.
- Receive first (high) byte of Address (bits SSPIF and BF are set).
- Read the SSPBUF register (clears bit BF) and clear flag bit SSPIF.

**TABLE 8-2: DATA TRANSFER RECEIVED BYTE ACTIONS**

Status Bits as Data Transfer is Received		SSPSR → SSPBUF	Generate $\overline{ACK}$ Pulse	Set bit SSPIF (SSP Interrupt occurs if enabled)
BF	SSPOV			
0	0	Yes	Yes	Yes
1	0	No	No	Yes
1	1	No	No	Yes
0	1	Yes	No	Yes

Note: Shaded cells show the conditions where the user software did not properly clear the overflow condition.

# PIC16C63A/65B/73B/74B

## 8.3.1.2 RECEPTION

When the  $R/\overline{W}$  bit of the address byte is clear and an address match occurs, the  $R/\overline{W}$  bit of the SSPSTAT register is cleared. The received address is loaded into the SSPBUF register.

When the address byte overflow condition exists, then no acknowledge ( $\overline{ACK}$ ) pulse is given. An overflow condition is defined as either bit BF (SSPSTAT<0>) is set or bit SSPOV (SSPCON<6>) is set.

An SSP interrupt is generated for each data transfer byte. Flag bit SSPIF (PIR1<3>) must be cleared in software. The SSPSTAT register is used to determine the status of the byte.

**FIGURE 8-5: I<sup>2</sup>C WAVEFORMS FOR RECEPTION (7-BIT ADDRESS)**

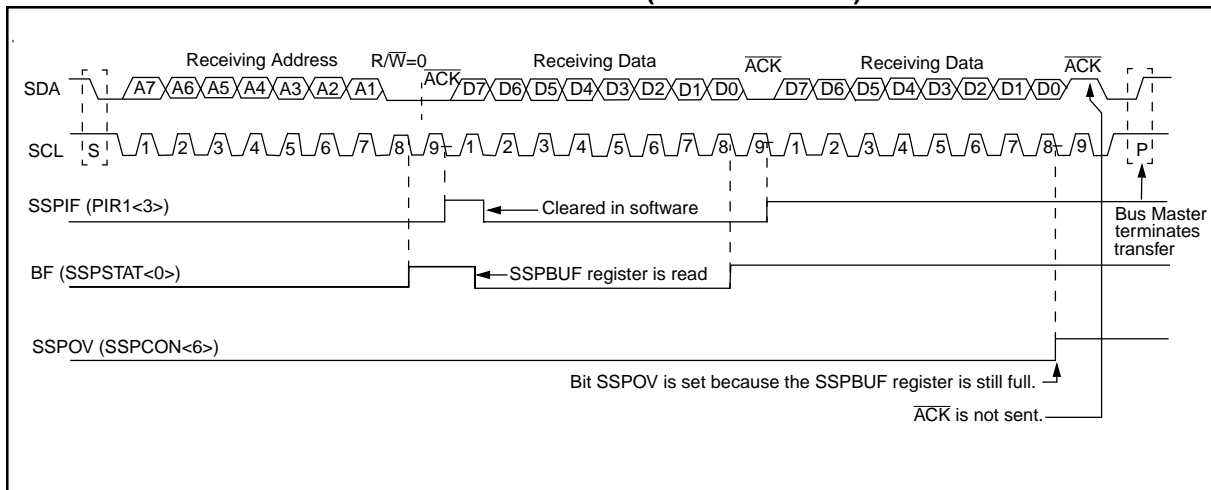

# PIC16C63A/65B/73B/74B

## 8.3.1.3 TRANSMISSION

When the  $R/\bar{W}$  bit of the incoming address byte is set and an address match occurs, the  $R/\bar{W}$  bit of the SSPSTAT register is set. The received address is loaded into the SSPBUF register. The  $\bar{ACK}$  pulse will be sent on the ninth bit, and pin RC3/SCK/SCL is held low. The transmit data must be loaded into the SSPBUF register, which also loads the SSPSR register. Then pin RC3/SCK/SCL should be enabled by setting bit CKP (SSPCON<4>). The master must monitor the SCL pin prior to asserting another clock pulse. The slave devices may be holding off the master by stretching the clock. The eight data bits are shifted out on the falling edge of the SCL input. This ensures that the SDA signal is valid during the SCL high time (Figure 8-6).

An SSP interrupt is generated for each data transfer byte. Flag bit SSPIF must be cleared in software, and the SSPSTAT register is used to determine the status of the byte. Flag bit SSPIF is set on the falling edge of the ninth clock pulse.

As a slave-transmitter, the  $\bar{ACK}$  pulse from the master-receiver is latched on the rising edge of the ninth SCL input pulse. If the SDA line was high (not  $\bar{ACK}$ ), then the data transfer is complete. When the  $\bar{ACK}$  is latched by the slave, the slave logic is reset (resets SSPSTAT register) and the slave then monitors for another occurrence of the START bit. If the SDA line was low ( $\bar{ACK}$ ), the transmit data must be loaded into the SSPBUF register, which also loads the SSPSR register. Then pin RC3/SCK/SCL should be enabled by setting bit CKP.

**FIGURE 8-6: I<sup>2</sup>C WAVEFORMS FOR TRANSMISSION (7-BIT ADDRESS)**

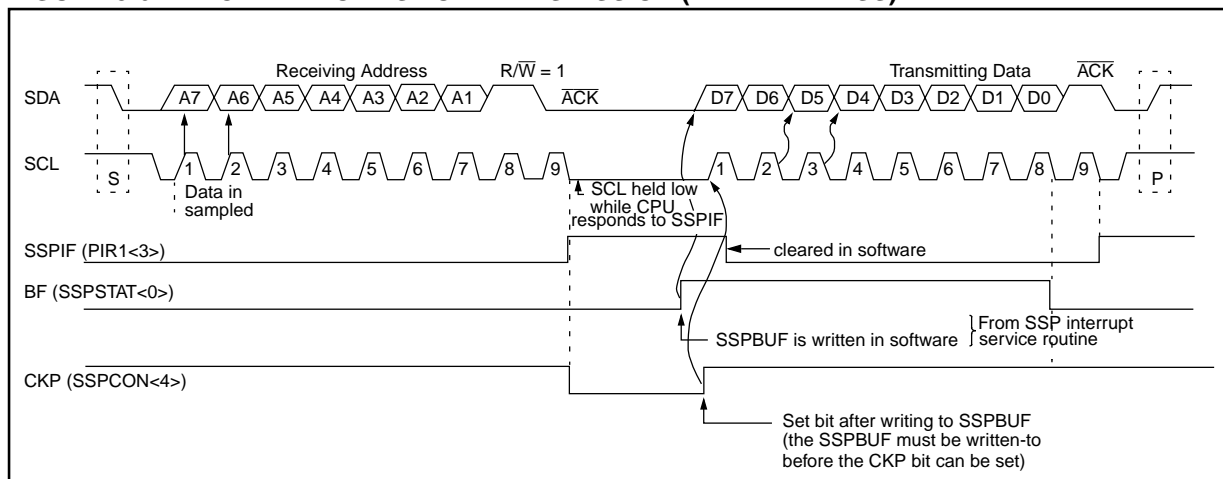

# PIC16C63A/65B/73B/74B

## 8.3.2 MASTER OPERATION

Master operation is supported in firmware using interrupt generation on the detection of the START and STOP conditions. The STOP (P) and START (S) bits are cleared from a reset or when the SSP module is disabled. The STOP (P) and START (S) bits will toggle based on the START and STOP conditions. Control of the I<sup>2</sup>C bus may be taken when the P bit is set, or the bus is idle and both the S and P bits are clear.

In master operation, the SCL and SDA lines are manipulated in firmware by clearing the corresponding TRISC<4:3> bit(s). The output level is always low, irrespective of the value(s) in PORTC<4:3>. So when transmitting data, a '1' data bit must have the TRISC<4> bit set (input) and a '0' data bit must have the TRISC<4> bit cleared (output). The same scenario is true for the SCL line with the TRISC<3> bit.

The following events will cause SSP Interrupt Flag bit, SSPIF, to be set (SSP Interrupt if enabled):

- START condition
- STOP condition
- Data transfer byte transmitted/received

Master operation can be done with either the slave mode idle (SSPM3:SSPM0 = 1011) or with the slave active. When both master operation and slave modes are used, the software needs to differentiate the source(s) of the interrupt.

For more information on master operation, see AN554 - Software Implementation of I<sup>2</sup>C Bus Master.

## 8.3.3 MULTI-MASTER OPERATION

In multi-master operation, the interrupt generation on the detection of the START and STOP conditions allows the determination of when the bus is free. The STOP (P) and START (S) bits are cleared from a reset or when the SSP module is disabled. The STOP (P) and START (S) bits will toggle based on the START and STOP conditions. Control of the I<sup>2</sup>C bus may be taken when bit P (SSPSTAT<4>) is set, or the bus is idle and both the S and P bits clear. When the bus is busy, enabling the SSP Interrupt will generate the interrupt when the STOP condition occurs.

In multi-master operation, the SDA line must be monitored to see if the signal level is the expected output level. This check only needs to be done when a high level is output. If a high level is expected and a low level is present, the device needs to release the SDA and SCL lines (set TRISC<4:3>). There are two stages where this arbitration can be lost, these are:

- Address Transfer
- Data Transfer

When the slave logic is enabled, the slave continues to receive. If arbitration was lost during the address transfer stage, communication to the device may be in progress. If addressed, an ACK pulse will be generated. If arbitration was lost during the data transfer stage, the device will need to re-transfer the data at a later time.

For more information on master operation, see AN578 - Use of the SSP Module in the of I<sup>2</sup>C Multi-Master Environment.

**TABLE 8-3: REGISTERS ASSOCIATED WITH I<sup>2</sup>C OPERATION**

Address	Name	Bit 7	Bit 6	Bit 5	Bit 4	Bit 3	Bit 2	Bit 1	Bit 0	Value on POR, BOR	Value on all other resets
0Bh, 8Bh	INTCON	GIE	PEIE	TOIE	INTE	RBIE	TOIF	INTF	RBIF	0000 000x	0000 000u
0Ch	PIR1	(1)	ADIF	(1)	(1)	SSPIF	CCP1IF	TMR2IF	TMR1IF	0000 0000	0000 0000
8Ch	PIE1	(1)	ADIE	(1)	(1)	SSPIE	CCP1IE	TMR2IE	TMR1IE	0000 0000	0000 0000
13h	SSPBUF	Synchronous Serial Port Receive Buffer/Transmit Register								xxxx xxxx	uuuu uuuu
93h	SSPAD	Synchronous Serial Port (I <sup>2</sup> C mode) Address Register								0000 0000	0000 0000
14h	SSPCON	WCOL	SSPOV	SSPEN	CKP	SSPM3	SSPM2	SSPM1	SSPM0	0000 0000	0000 0000
94h	SSPSTAT	SMP	CKE	D/ $\bar{A}$	P	S	R/ $\bar{W}$	UA	BF	0000 0000	0000 0000
87h	TRISC	PORTC Data Direction register								1111 1111	1111 1111

Legend: x = unknown, u = unchanged, - = unimplemented locations read as '0'.

Shaded cells are not used by SSP module in SPI mode.

Note 1: These bits are unimplemented, read as '0'.

# PIC16C63A/65B/73B/74B

## 9.0 UNIVERSAL SYNCHRONOUS ASYNCHRONOUS RECEIVER TRANSMITTER (USART)

The Universal Synchronous Asynchronous Receiver Transmitter (USART) module is one of the two serial I/O modules. (USART is also known as a Serial Communications Interface or SCI). The USART can be configured as a full duplex asynchronous system that can communicate with peripheral devices such as CRT terminals and personal computers, or it can be configured as a half duplex synchronous system that can communicate with peripheral devices such as A/D or D/A integrated circuits, Serial EEPROMs etc.

The USART can be configured in the following modes:

- Asynchronous (full duplex)
- Synchronous - Master (half duplex)
- Synchronous - Slave (half duplex)

Bit SPEN (RCSTA<7>), and bits TRISC<7:6>, have to be set in order to configure pins RC6/TX/CK and RC7/RX/DT as the Universal Synchronous Asynchronous Receiver Transmitter.

**FIGURE 9-1: TXSTA: TRANSMIT STATUS AND CONTROL REGISTER (ADDRESS 98h)**

R/W-0	R/W-0	R/W-0	R/W-0	U-0	R/W-0	R-1	R/W-0
CSRC	TX9	TXEN	SYNC	—	BRGH	TRMT	TX9D
							bit0
<div style="border: 1px solid black; padding: 5px; float: right; width: 150px;">                     R = Readable bit                      W = Writable bit                      U = Unimplemented bit,                      read as '0'                      - n =Value at POR reset                 </div>							
bit 7: <b>CSRC:</b> Clock Source Select bit <u>Asynchronous mode</u> Don't care <u>Synchronous mode</u> 1 = Master mode (Clock generated internally from BRG) 0 = Slave mode (Clock from external source)							
bit 6: <b>TX9:</b> 9-bit Transmit Enable bit 1 = Selects 9-bit transmission 0 = Selects 8-bit transmission							
bit 5: <b>TXEN:</b> Transmit Enable bit 1 = Transmit enabled 0 = Transmit disabled Note: SREN/CREN overrides TXEN in SYNC mode.							
bit 4: <b>SYNC:</b> USART Mode Select bit 1 = Synchronous mode 0 = Asynchronous mode							
bit 3: <b>Unimplemented:</b> Read as '0'							
bit 2: <b>BRGH:</b> High Baud Rate Select bit <u>Asynchronous mode</u> 1 = High speed 0 = Low speed <u>Synchronous mode</u> Unused in this mode							
bit 1: <b>TRMT:</b> Transmit Shift Register Status bit 1 = TSR empty 0 = TSR full							
bit 0: <b>TX9D:</b> 9th bit of transmit data. Can be parity bit.							

# PIC16C63A/65B/73B/74B

FIGURE 9-2: RCSTA: RECEIVE STATUS AND CONTROL REGISTER (ADDRESS 18h)

R/W-0	R/W-0	R/W-0	R/W-0	U-0	R-0	R-0	R-x
SPEN	RX9	SREN	CREN	—	FERR	OERR	RX9D
bit7							bit0

R = Readable bit  
W = Writable bit  
U = Unimplemented bit, read as '0'  
- n = Value at POR reset

bit 7: **SPEN**: Serial Port Enable bit  
1 = Serial port enabled (Configures RC7/RX/DT and RC6/TX/CK pins as serial port pins)  
0 = Serial port disabled

bit 6: **RX9**: 9-bit Receive Enable bit  
1 = Selects 9-bit reception  
0 = Selects 8-bit reception

bit 5: **SREN**: Single Receive Enable bit  
Asynchronous mode  
Don't care  
Synchronous mode - master  
1 = Enables single receive  
0 = Disables single receive  
This bit is cleared after reception is complete.  
Synchronous mode - slave  
Unused in this mode

bit 4: **CREN**: Continuous Receive Enable bit  
Asynchronous mode  
1 = Enables continuous receive  
0 = Disables continuous receive  
Synchronous mode  
1 = Enables continuous receive until enable bit CREN is cleared (CREN overrides SREN)  
0 = Disables continuous receive

bit 3: **Unimplemented**: Read as '0'

bit 2: **FERR**: Framing Error bit  
1 = Framing error (Can be updated by reading RCREG register and receive next valid byte)  
0 = No framing error

bit 1: **OERR**: Overrun Error bit  
1 = Overrun error (Can be cleared by clearing bit CREN)  
0 = No overrun error

bit 0: **RX9D**: 9th bit of received data (Can be parity bit)

# PIC16C63A/65B/73B/74B

## 9.1 USART Baud Rate Generator (BRG)

The BRG supports both the Asynchronous and Synchronous modes of the USART. It is a dedicated 8-bit baud rate generator. The SPBRG register controls the period of a free running 8-bit timer. In asynchronous mode bit BRGH (TXSTA<2>) also controls the baud rate. In synchronous mode bit BRGH is ignored. Table 9-1 shows the formula for computation of the baud rate for different USART modes which only apply in master mode (internal clock).

Given the desired baud rate and Fosc, the nearest integer value for the SPBRG register can be calculated using the formula in Table 9-1. From this, the error in baud rate can be determined.

Example 9-1 shows the calculation of the baud rate error for the following conditions:

Fosc = 16 MHz  
 Desired Baud Rate = 9600  
 BRGH = 0  
 SYNC = 0

### EXAMPLE 9-1: CALCULATING BAUD RATE ERROR

$$\begin{aligned} \text{Desired Baud rate} &= F_{osc} / (64 (X + 1)) \\ 9600 &= 16000000 / (64 (X + 1)) \\ X &= \lfloor 25.042 \rfloor = 25 \\ \text{Calculated Baud Rate} &= 16000000 / (64 (25 + 1)) \\ &= 9615 \\ \text{Error} &= \frac{(\text{Calculated Baud Rate} - \text{Desired Baud Rate})}{\text{Desired Baud Rate}} \\ &= (9615 - 9600) / 9600 \\ &= 0.16\% \end{aligned}$$

It may be advantageous to use the high baud rate (BRGH = 1) even for slower baud clocks. This is because the  $F_{osc}/(16(X + 1))$  equation can reduce the baud rate error in some cases.

Writing a new value to the SPBRG register causes the BRG timer to be reset (or cleared). This ensures the BRG does not wait for a timer overflow before outputting the new baud rate.

#### 9.1.1 SAMPLING

The data on the RC7/RX/DT pin is sampled three times by a majority detect circuit to determine if a high or a low level is present at the RX pin.

TABLE 9-1: BAUD RATE FORMULA

SYNC	BRGH = 0 (Low Speed)	BRGH = 1 (High Speed)
0	(Asynchronous) Baud Rate = $F_{osc}/(64(X+1))$	Baud Rate = $F_{osc}/(16(X+1))$
1	(Synchronous) Baud Rate = $F_{osc}/(4(X+1))$	NA

X = value in SPBRG (0 to 255)

TABLE 9-2: REGISTERS ASSOCIATED WITH BAUD RATE GENERATOR

Address	Name	Bit 7	Bit 6	Bit 5	Bit 4	Bit 3	Bit 2	Bit 1	Bit 0	Value on POR, BOR	Value on all other resets	
98h	TXSTA	CSRC	TX9	TXEN	SYNC	—	BRGH	TRMT	TX9D	0000 -010	0000 -010	
18h	RCSTA	SPEN	RX9	SREN	CREN	—	FERR	OERR	RX9D	0000 -00x	0000 -00x	
99h	SPBRG	Baud Rate Generator Register									0000 0000	0000 0000

Legend: x = unknown, - = unimplemented read as '0'. Shaded cells are not used by the BRG.

# PIC16C63A/65B/73B/74B

**TABLE 9-3: BAUD RATES FOR SYNCHRONOUS MODE**

BAUD RATE (K)	FOSC = 20 MHz			16 MHz			10 MHz			7.15909 MHz		
	KBAUD	%	SPBRG value (decimal)	KBAUD	%	SPBRG value (decimal)	KBAUD	%	SPBRG value (decimal)	KBAUD	%	SPBRG value (decimal)
0.3	NA	-	-	NA	-	-	NA	-	-	NA	-	-
1.2	NA	-	-	NA	-	-	NA	-	-	NA	-	-
2.4	NA	-	-	NA	-	-	NA	-	-	NA	-	-
9.6	NA	-	-	NA	-	-	9.766	+1.73	255	9.622	+0.23	185
19.2	19.53	+1.73	255	19.23	+0.16	207	19.23	+0.16	129	19.24	+0.23	92
76.8	76.92	+0.16	64	76.92	+0.16	51	75.76	-1.36	32	77.82	+1.32	22
96	96.15	+0.16	51	95.24	-0.79	41	96.15	+0.16	25	94.20	-1.88	18
300	294.1	-1.96	16	307.69	+2.56	12	312.5	+4.17	7	298.3	-0.57	5
500	500	0	9	500	0	7	500	0	4	NA	-	-
HIGH	5000	-	0	4000	-	0	2500	-	0	1789.8	-	0
LOW	19.53	-	255	15.625	-	255	9.766	-	255	6.991	-	255

BAUD RATE (K)	FOSC = 5.0688 MHz			4 MHz			3.579545 MHz			1 MHz			32.768 kHz		
	KBAUD	%	SPBRG	KBAUD	%	SPBRG value (decimal)	KBAUD	%	SPBRG value (decimal)	KBAUD	%	SPBRG value (decimal)	KBAUD	%	SPBRG value (decimal)
0.3	NA	-	-	NA	-	-	NA	-	-	NA	-	-	0.303	+1.14	26
1.2	NA	-	-	NA	-	-	NA	-	-	1.202	+0.16	207	1.170	-2.48	6
2.4	NA	-	-	NA	-	-	NA	-	-	2.404	+0.16	103	NA	-	-
9.6	9.6	0	131	9.615	+0.16	103	9.622	+0.23	92	9.615	+0.16	25	NA	-	-
19.2	19.2	0	65	19.231	+0.16	51	19.04	-0.83	46	19.24	+0.16	12	NA	-	-
76.8	79.2	+3.13	15	76.923	+0.16	12	74.57	-2.90	11	83.34	+8.51	2	NA	-	-
96	97.48	+1.54	12	1000	+4.17	9	99.43	+3.57	8	NA	-	-	NA	-	-
300	316.8	+5.60	3	NA	-	-	298.3	-0.57	2	NA	-	-	NA	-	-
500	NA	-	-	NA	-	-	NA	-	-	NA	-	-	NA	-	-
HIGH	1267	-	0	100	-	0	894.9	-	0	250	-	0	8.192	-	0
LOW	4.950	-	255	3.906	-	255	3.496	-	255	0.9766	-	255	0.032	-	255

**TABLE 9-4: BAUD RATES FOR ASYNCHRONOUS MODE (BRGH = 0)**

BAUD RATE (K)	FOSC = 20 MHz			16 MHz			10 MHz			7.15909 MHz		
	%	SPBRG value (decimal)		%	SPBRG value (decimal)		%	SPBRG value (decimal)	%	SPBRG value (decimal)		
0.3	NA	-	-	NA	-	-	NA	-	-	NA	-	-
1.2	1.221	+1.73	255	1.202	+0.16	207	1.202	+0.16	129	1.203	+0.23	92
2.4	2.404	+0.16	129	2.404	+0.16	103	2.404	+0.16	64	2.380	-0.83	46
9.6	9.469	-1.36	32	9.615	+0.16	25	9.766	+1.73	15	9.322	-2.90	11
19.2	19.53	+1.73	15	19.23	+0.16	12	19.53	+1.73	7	18.64	-2.90	5
76.8	78.13	+1.73	3	83.33	+8.51	2	78.13	+1.73	1	NA	-	-
96	104.2	+8.51	2	NA	-	-	NA	-	-	NA	-	-
300	312.5	+4.17	0	NA	-	-	NA	-	-	NA	-	-
500	NA	-	-	NA	-	-	NA	-	-	NA	-	-
HIGH	312.5	-	0	250	-	0	156.3	-	0	111.9	-	0
LOW	1.221	-	255	0.977	-	255	0.6104	-	255	0.437	-	255

BAUD RATE (K)	Fosc = 5.0688 MHz			4 MHz			3.579545 MHz			1 MHz			32.768 kHz		
	%	SPBRG		%	SPBRG value (decimal)		%	SPBRG value (decimal)	%	SPBRG value (decimal)	%	SPBRG value (decimal)	%	SPBRG value (decimal)	
0.3	0.31	+3.13	255	0.3005	-0.17	207	0.301	+0.23	185	0.300	+0.16	51	0.256	-14.67	1
1.2	1.2	0	65	1.202	+1.67	51	1.190	-0.83	46	1.202	+0.16	12	NA	-	-
2.4	2.4	0	32	2.404	+1.67	25	2.432	+1.32	22	2.232	-6.99	6	NA	-	-
9.6	9.9	+3.13	7	NA	-	-	9.322	-2.90	5	NA	-	-	NA	-	-
19.2	19.8	+3.13	3	NA	-	-	18.64	-2.90	2	NA	-	-	NA	-	-
76.8	79.2	+3.13	0	NA	-	-	NA	-	-	NA	-	-	NA	-	-
96	NA	-	-	NA	-	-	NA	-	-	NA	-	-	NA	-	-
300	NA	-	-	NA	-	-	NA	-	-	NA	-	-	NA	-	-
500	NA	-	-	NA	-	-	NA	-	-	NA	-	-	NA	-	-
HIGH	79.2	-	0	62.500	-	0	55.93	-	0	15.63	-	0	0.512	-	0
LOW	0.3094	-	255	3.906	-	255	0.2185	-	255	0.0610	-	255	0.0020	-	255



# PIC16C63A/65B/73B/74B

**TABLE 9-5: BAUD RATES FOR ASYNCHRONOUS MODE (BRGH = 1)**

BAUD RATE (K)	FOSC = 20 MHz			16 MHz			10 MHz			7.16 MHz		
	%	SPBRG value (decimal)		%	SPBRG value (decimal)		%	SPBRG value (decimal)		%	SPBRG value (decimal)	
9.6	9.615	+0.16	129	9.615	+0.16	103	9.615	+0.16	64	9.520	-0.83	46
19.2	19.230	+0.16	64	19.230	+0.16	51	18.939	-1.36	32	19.454	+1.32	22
38.4	37.878	-1.36	32	38.461	+0.16	25	39.062	+1.7	15	37.286	-2.90	11
57.6	56.818	-1.36	21	58.823	+2.12	16	56.818	-1.36	10	55.930	-2.90	7
115.2	113.636	-1.36	10	111.111	-3.55	8	125	+8.51	4	111.860	-2.90	3
250	250	0	4	250	0	3	NA	-	-	NA	-	-
625	625	0	1	NA	-	-	625	0	0	NA	-	-
1250	1250	0	0	NA	-	-	NA	-	-	NA	-	-

BAUD RATE (K)	FOSC = 5.068			4 MHz			3.579 MHz			1 MHz			32.768 kHz		
	%	SPBRG value (decimal)		%	SPBRG value (decimal)		%	SPBRG value (decimal)		%	SPBRG value (decimal)		%	SPBRG value (decimal)	
9.6	9.6	0	32	NA	-	-	9.727	+1.32	22	8.928	-6.99	6	NA	-	-
19.2	18.645	-2.94	16	1.202	+0.17	207	18.643	-2.90	11	20.833	+8.51	2	NA	-	-
38.4	39.6	+3.12	7	2.403	+0.13	103	37.286	-2.90	5	31.25	-18.61	1	NA	-	-
57.6	52.8	-8.33	5	9.615	+0.16	25	55.930	-2.90	3	62.5	+8.51	0	NA	-	-
115.2	105.6	-8.33	2	19.231	+0.16	12	111.860	-2.90	1	NA	-	-	NA	-	-
250	NA	-	-	NA	-	-	223.721	-10.51	0	NA	-	-	NA	-	-
625	NA	-	-	NA	-	-	NA	-	-	NA	-	-	NA	-	-
1250	NA	-	-	NA	-	-	NA	-	-	NA	-	-	NA	-	-

# PIC16C63A/65B/73B/74B

## 9.2 USART Asynchronous Mode

In this mode, the USART uses standard non-return-to-zero (NRZ) format (one start bit, eight or nine data bits and one stop bit). The most common data format is 8-bits. An on-chip dedicated 8-bit baud rate generator can be used to derive standard baud rate frequencies from the oscillator. The USART transmits and receives the LSb first. The USART's transmitter and receiver are functionally independent, but use the same data format and baud rate. The baud rate generator produces a clock, either x16 or x64 of the bit shift rate, depending on bit BRGH (TXSTA<2>). Parity is not supported by the hardware, but can be implemented in software (and stored as the ninth data bit). Asynchronous mode is stopped during SLEEP.

Asynchronous mode is selected by clearing bit SYNC (TXSTA<4>).

The USART Asynchronous module consists of the following important elements:

- Baud Rate Generator
- Sampling Circuit
- Asynchronous Transmitter
- Asynchronous Receiver

### 9.2.1 USART ASYNCHRONOUS TRANSMITTER

The USART transmitter block diagram is shown in Figure 9-3. The heart of the transmitter is the transmit (serial) shift register (TSR). The shift register obtains its data from the read/write transmit buffer, TXREG. The TXREG register is loaded with data in software. The TSR register is not loaded until the STOP bit has been transmitted from the previous load. As soon as the STOP bit is transmitted, the TSR is loaded with new data from the TXREG register (if available). Once the TXREG register transfers the data to the TSR register

(occurs in one T<sub>CY</sub>), the TXREG register is empty and flag bit TXIF (PIR1<4>) is set. This interrupt can be enabled/disabled by setting/clearing enable bit TXIE (PIE1<4>). Flag bit TXIF will be set regardless of the state of enable bit TXIE and cannot be cleared in software. It will reset only when new data is loaded into the TXREG register. While flag bit TXIF indicated the status of the TXREG register, another bit TRMT (TXSTA<1>) shows the status of the TSR register. Status bit TRMT is a read only bit which is set when the TSR register is empty. No interrupt logic is tied to this bit, so the user has to poll this bit in order to determine if the TSR register is empty.

**Note 1:** The TSR register is not mapped in data memory so it is not available to the user.

**Note 2:** Flag bit TXIF is set when enable bit TXEN is set.

Steps to follow when setting up an asynchronous transmission:

1. Initialize the SPBRG register for the appropriate baud rate. If a high speed baud rate is desired, set bit BRGH. (Section 9.1)
2. Enable the asynchronous serial port by clearing bit SYNC and setting bit SPEN.
3. If interrupts are desired, then set enable bit TXIE.
4. If 9-bit transmission is desired, then set transmit bit TX9.
5. Enable the transmission by setting bit TXEN, which will also set bit TXIF.
6. If 9-bit transmission is selected, the ninth bit should be loaded in bit TX9D.
7. Load data to the TXREG register (starts transmission).

**FIGURE 9-3: USART TRANSMIT BLOCK DIAGRAM**

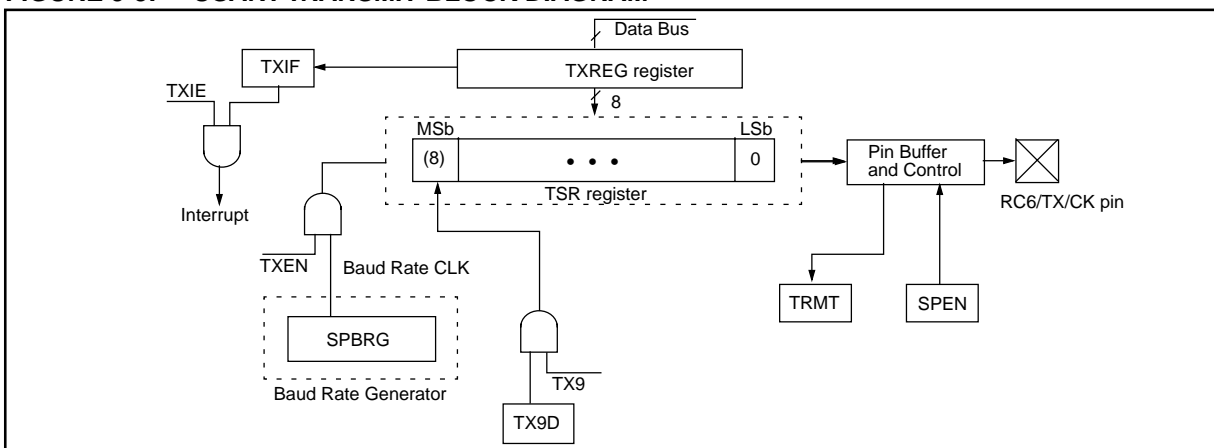

# PIC16C63A/65B/73B/74B

**FIGURE 9-4: ASYNCHRONOUS TRANSMISSION**

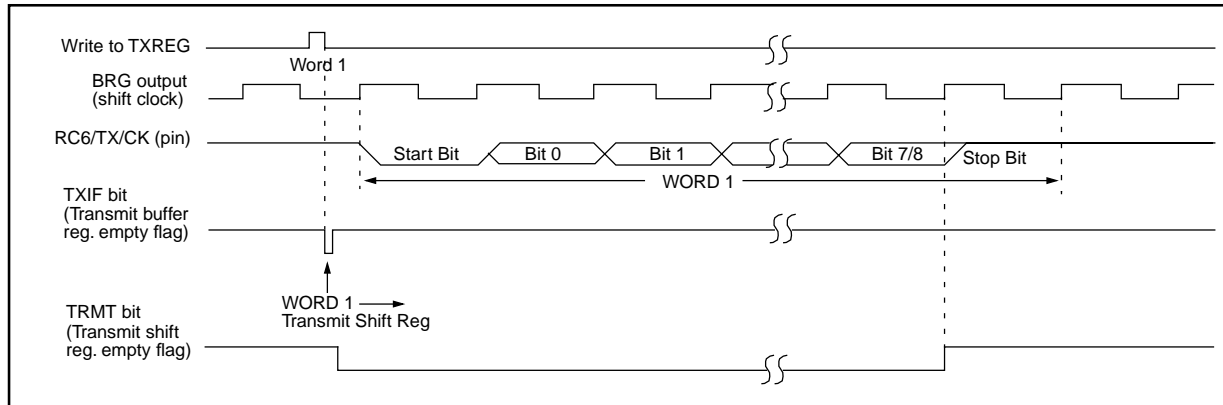

**FIGURE 9-5: ASYNCHRONOUS TRANSMISSION (BACK TO BACK)**

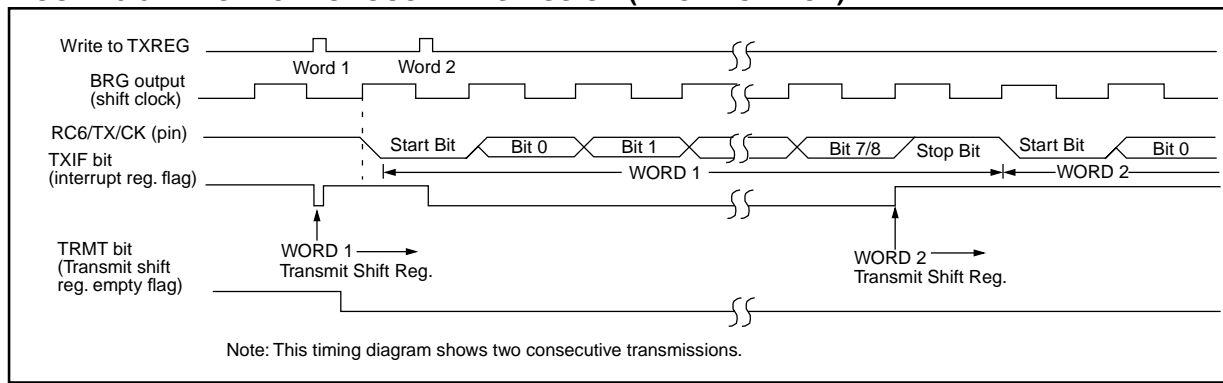

**TABLE 9-6: REGISTERS ASSOCIATED WITH ASYNCHRONOUS TRANSMISSION**

Address	Name	Bit 7	Bit 6	Bit 5	Bit 4	Bit 3	Bit 2	Bit 1	Bit 0	Value on POR, BOR	Value on all other Resets
0Ch	PIR1	PSPIF <sup>(1)</sup>	ADIF <sup>(2)</sup>	RCIF	TXIF	SSPIF	CCP1IF	TMR2IF	TMR1IF	0000 0000	0000 0000
18h	RCSTA	SPEN	RX9	SREN	CREN	—	FERR	OERR	RX9D	0000 -00x	0000 -00x
19h	TXREG	USART Transmit Register								0000 0000	0000 0000
8Ch	PIE1	PSPIE <sup>(1)</sup>	ADIE <sup>(2)</sup>	RCIE	TXIE	SSPIE	CCP1IE	TMR2IE	TMR1IE	0000 0000	0000 0000
98h	TXSTA	CSRC	TX9	TXEN	SYNC	—	BRGH	TRMT	TX9D	0000 -010	0000 -010
99h	SPBRG	Baud Rate Generator Register								0000 0000	0000 0000

Legend: x = unknown, - = unimplemented locations read as '0'. Shaded cells are not used for Asynchronous Transmission.

Note 1: PORTD and PORTE not implemented on the PIC16C63A/73B, maintain as '0'.

2: A/D not implemented on the PIC16C63A/65B, maintain as '0'.

# PIC16C63A/65B/73B/74B

## 9.2.2 USART ASYNCHRONOUS RECEIVER

The receiver block diagram is shown in Figure 9-6. The data is received on the RC7/RX/DT pin and drives the data recovery block. The data recovery block is actually a high speed shifter operating at x16 times the baud rate, whereas the main receive serial shifter operates at the bit rate or at FOSC.

Steps to follow when setting up an Asynchronous Reception:

1. Initialize the SPBRG register for the appropriate baud rate. If a high speed baud rate is desired, set bit BRGH. (Section 9.1).
2. Enable the asynchronous serial port by clearing bit SYNC, and setting bit SPEN.
3. If interrupts are desired, then set enable bit RCIE.
4. If 9-bit reception is desired, then set bit RX9.
5. Enable the reception by setting bit CREN.
6. Flag bit RCIF will be set when reception is complete and an interrupt will be generated if enable bit RCIE was set.
7. Read the RCSTA register to get the ninth bit (if enabled) and determine if any error occurred during reception.
8. Read the 8-bit received data by reading the RCREG register.
9. If any error occurred, clear the error by clearing enable bit CREN.

**FIGURE 9-6: USART RECEIVE BLOCK DIAGRAM**

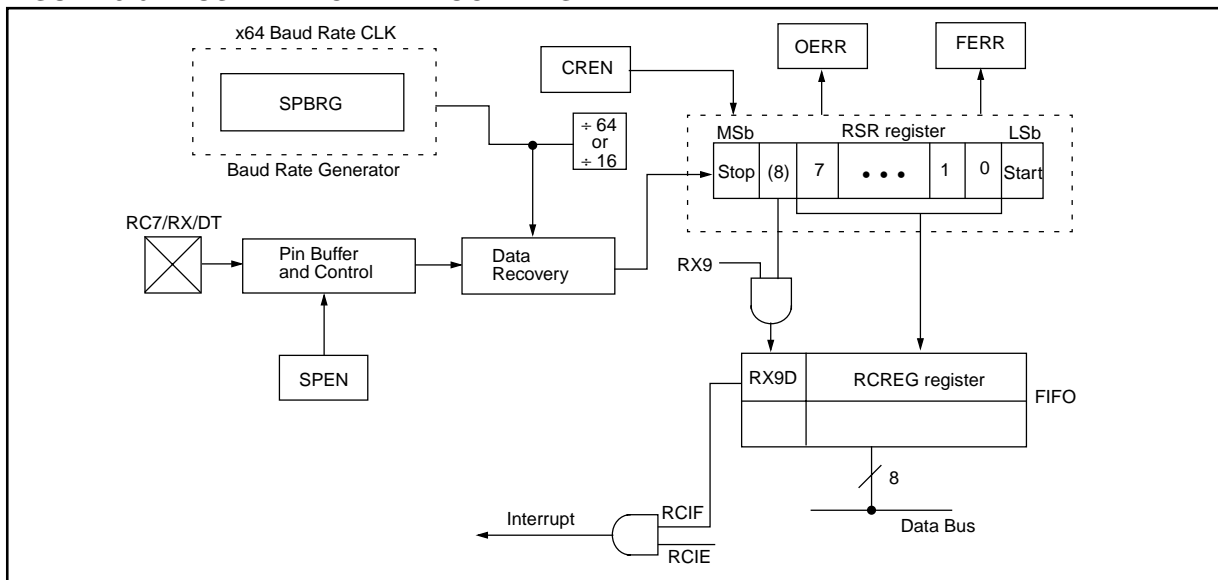

**FIGURE 9-7: ASYNCHRONOUS RECEPTION**

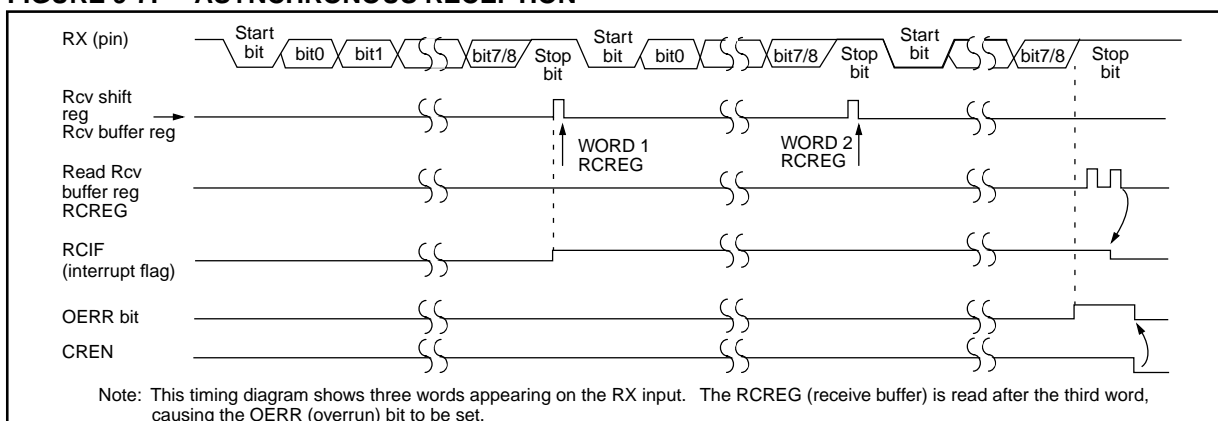

# PIC16C63A/65B/73B/74B

**TABLE 9-7: REGISTERS ASSOCIATED WITH ASYNCHRONOUS RECEPTION**

Address	Name	Bit 7	Bit 6	Bit 5	Bit 4	Bit 3	Bit 2	Bit 1	Bit 0	Value on POR, BOR	Value on all other Resets
0Ch	PIR1	PSPIF <sup>(1)</sup>	ADIF <sup>(2)</sup>	RCIF	TXIF	SSPIF	CCP1IF	TMR2IF	TMR1IF	0000 0000	0000 0000
18h	RCSTA	SPEN	RX9	SREN	CREN	—	FERR	OERR	RX9D	0000 -00x	0000 -00x
1Ah	RCREG	USART Receive Register								0000 0000	0000 0000
8Ch	PIE1	PSPIE <sup>(1)</sup>	ADIE <sup>(2)</sup>	RCIE	TXIE	SSPIE	CCP1IE	TMR2IE	TMR1IE	0000 0000	0000 0000
98h	TXSTA	CSRC	TX9	TXEN	SYNC	—	BRGH	TRMT	TX9D	0000 -010	0000 -010
99h	SPBRG	Baud Rate Generator Register								0000 0000	0000 0000

Legend: x = unknown, - = unimplemented locations read as '0'. Shaded cells are not used for Asynchronous Reception.

Note 1: Bits PSPIE and PSPIF are reserved on the PIC16C63A/73B, always maintain these bits clear.

2: Bits ADIE and ADIF are reserved on the PIC16C63A/65B, always maintain these bits clear.

# PIC16C63A/65B/73B/74B

## 9.3 USART Synchronous Master Mode

In Synchronous Master mode, the data is transmitted in a half-duplex manner, i.e. transmission and reception do not occur at the same time. When transmitting data, the reception is inhibited and vice versa. Synchronous mode is entered by setting bit SYNC (TXSTA<4>). In addition, enable bit SPEN (RCSTA<7>) is set in order to configure the RC6/TX/CK and RC7/RX/DT I/O pins to CK (clock) and DT (data) lines respectively. The Master mode indicates that the processor transmits the master clock on the CK line. The Master mode is entered by setting bit CSRC (TXSTA<7>).

### 9.3.1 USART SYNCHRONOUS MASTER TRANSMISSION

The USART transmitter block diagram is shown in Figure 9-3. The heart of the transmitter is the transmit (serial) shift register (TSR). The shift register obtains its data from the read/write transmit buffer register TXREG. The TXREG register is loaded with data in software. The TSR register is not loaded until the last bit has been transmitted from the previous load. As soon as the last bit is transmitted, the TSR is loaded with new data from the TXREG (if available). Once the TXREG register transfers the data to the TSR register (occurs in one Tcycle), the TXREG is empty and interrupt bit TXIF (PIR1<4>) is set. The interrupt can be

enabled/disabled by setting/clearing enable bit TXIE (PIE1<4>). Flag bit TXIF will be set regardless of the state of enable bit TXIE and cannot be cleared in software. It will reset only when new data is loaded into the TXREG register. While flag bit TXIF indicates the status of the TXREG register, another bit TRMT (TXSTA<1>) shows the status of the TSR register. TRMT is a read only bit which is set when the TSR is empty. No interrupt logic is tied to this bit, so the user has to poll this bit in order to determine if the TSR register is empty. The TSR is not mapped in data memory so it is not available to the user.

Steps to follow when setting up a Synchronous Master Transmission:

1. Initialize the SPBRG register for the appropriate baud rate (Section 9.1).
2. Enable the synchronous master serial port by setting bits SYNC, SPEN, and CSRC.
3. If interrupts are desired, then set enable bit TXIE.
4. If 9-bit transmission is desired, then set bit TX9.
5. Enable the transmission by setting bit TXEN.
6. If 9-bit transmission is selected, the ninth bit should be loaded in bit TX9D.
7. Start transmission by loading data to the TXREG register.

**TABLE 9-8: REGISTERS ASSOCIATED WITH SYNCHRONOUS MASTER TRANSMISSION**

Address	Name	Bit 7	Bit 6	Bit 5	Bit 4	Bit 3	Bit 2	Bit 1	Bit 0	Value on POR, BOR	Value on all other Resets
0Ch	PIR1	PSPIF <sup>(1)</sup>	ADIF <sup>(2)</sup>	RCIF	TXIF	SSPIF	CCP1IF	TMR2IF	TMR1IF	0000 0000	0000 0000
18h	RCSTA	SPEN	RX9	SREN	CREN	—	FERR	OERR	RX9D	0000 -00x	0000 -00x
19h	TXREG	USART Transmit Register								0000 0000	0000 0000
8Ch	PIE1	PSPIE <sup>(1)</sup>	ADIE <sup>(2)</sup>	RCIE	TXIE	SSPIE	CCP1IE	TMR2IE	TMR1IE	0000 0000	0000 0000
98h	TXSTA	CSRC	TX9	TXEN	SYNC	—	BRGH	TRMT	TX9D	0000 -010	0000 -010
99h	SPBRG	Baud Rate Generator Register								0000 0000	0000 0000

Legend: x = unknown, - = unimplemented, read as '0'. Shaded cells are not used for Synchronous Master Transmission.

Note 1: Bits PSPIE and PSPIF are reserved on the PIC16C63A/73B, always maintain these bits clear.

Note 2: Bits ADIE and ADIF are reserved on the PIC16C63A/65B, always maintain these bits clear.

# PIC16C63A/65B/73B/74B

**FIGURE 9-8: SYNCHRONOUS TRANSMISSION**

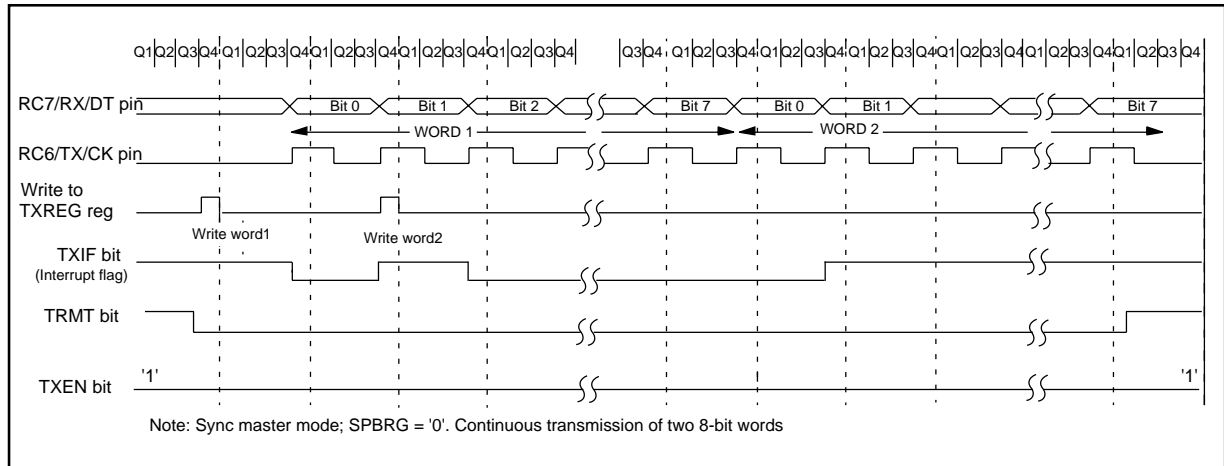

**FIGURE 9-9: SYNCHRONOUS TRANSMISSION (THROUGH TXEN)**

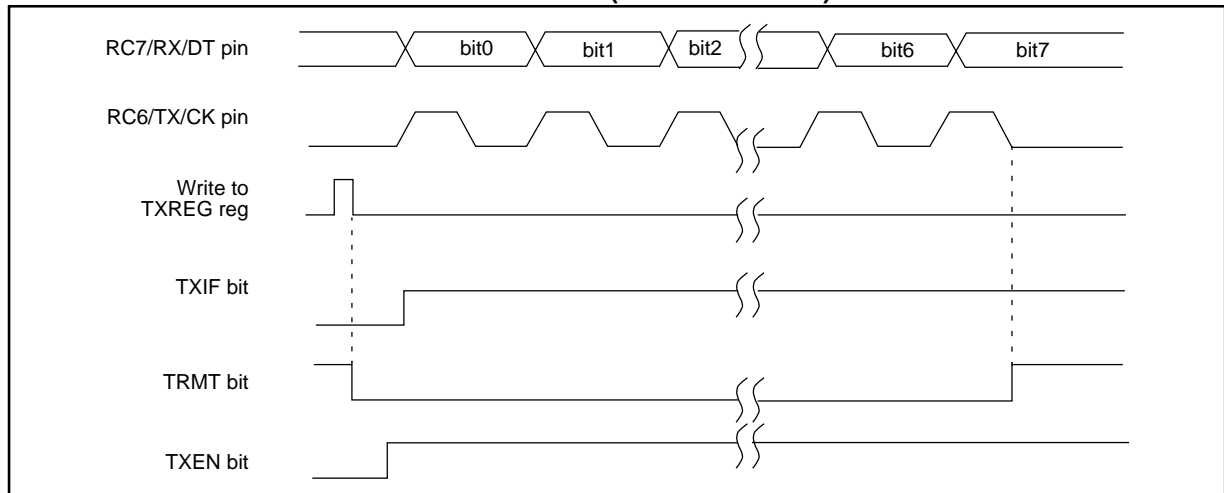

# PIC16C63A/65B/73B/74B

## 9.3.2 USART SYNCHRONOUS MASTER RECEPTION

Once synchronous mode is selected, reception is enabled by setting either enable bit SREN (RCSTA<5>) or enable bit CREN (RCSTA<4>). Data is sampled on the RC7/RX/DT pin on the falling edge of the clock. If enable bit SREN is set, then only a single word is received. If enable bit CREN is set, the reception is continuous until CREN is cleared. If both bits are set, then CREN takes precedence.

Steps to follow when setting up a Synchronous Master Reception:

1. Initialize the SPBRG register for the appropriate baud rate. (Section 9.1)
2. Enable the synchronous master serial port by setting bits SYNC, SPEN, and CSRC.
3. Ensure bits CREN and SREN are clear.
4. If interrupts are desired, then set enable bit RCIE.
5. If 9-bit reception is desired, then set bit RX9.
6. If a single reception is required, set bit SREN. For continuous reception, set bit CREN.
7. Interrupt flag bit RCIF will be set when reception is complete and an interrupt will be generated if enable bit RCIE was set.
8. Read the RCSTA register to get the ninth bit (if enabled) and determine if any error occurred during reception.
9. Read the 8-bit received data by reading the RCREG register.
10. If any error occurred, clear the error by clearing bit CREN.

**TABLE 9-9: REGISTERS ASSOCIATED WITH SYNCHRONOUS MASTER RECEPTION**

Address	Name	Bit 7	Bit 6	Bit 5	Bit 4	Bit 3	Bit 2	Bit 1	Bit 0	Value on: POR, BOR	Value on all other Resets
0Ch	PIR1	PSPIF <sup>(1)</sup>	ADIF <sup>(2)</sup>	RCIF	TXIF	SSPIF	CCP1IF	TMR2IF	TMR1IF	0000 0000	0000 0000
18h	RCSTA	SPEN	RX9	SREN	CREN	—	FERR	OERR	RX9D	0000 -00x	0000 -00x
1Ah	RCREG	USART Receive Register								0000 0000	0000 0000
8Ch	PIE1	PSPIE <sup>(1)</sup>	ADIE <sup>(2)</sup>	RCIE	TXIE	SSPIE	CCP1IE	TMR2IE	TMR1IE	0000 0000	0000 0000
98h	TXSTA	CSRC	TX9	TXEN	SYNC	—	BRGH	TRMT	TX9D	0000 -010	0000 -010
99h	SPBRG	Baud Rate Generator Register								0000 0000	0000 0000

Legend: x = unknown, - = unimplemented read as '0'. Shaded cells are not used for Synchronous Master Reception.

Note 1: Bits PSPIE and PSPIF are reserved on the PIC16C63A/73B. Always maintain these bits clear.

Note 2: Bits ADIE and ADIF are reserved on the PIC16C63A/65B. Always maintain these bits clear.

**FIGURE 9-10: SYNCHRONOUS RECEPTION (MASTER MODE, SREN)**

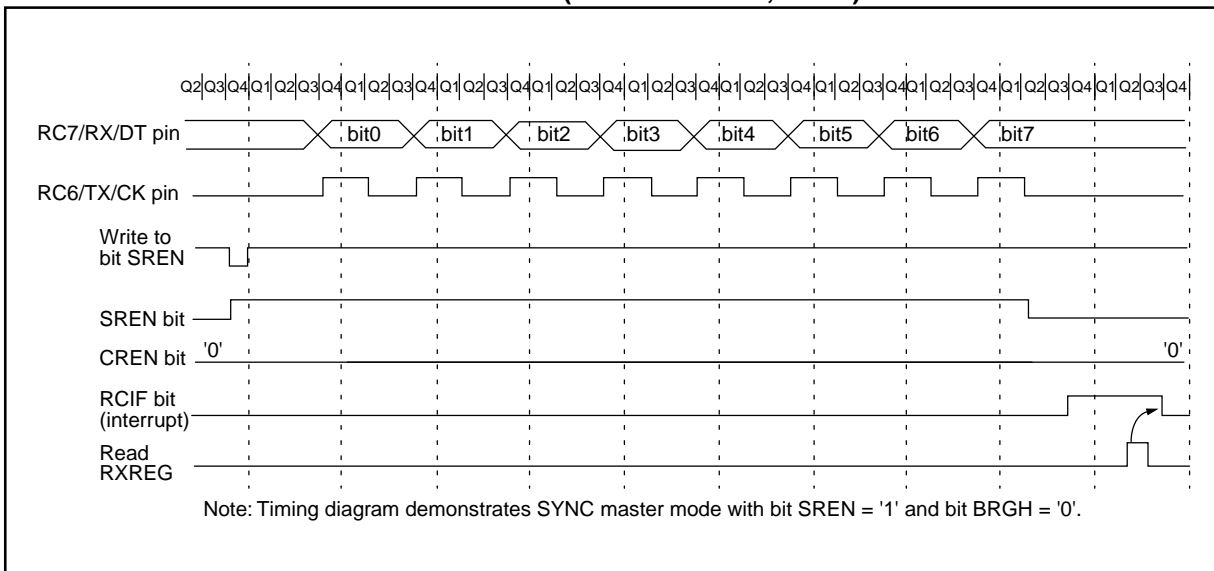



## 9.4 USART Synchronous Slave Mode

Synchronous slave mode differs from the Master mode in the fact that the shift clock is supplied externally at the RC6/TX/CK pin (instead of being supplied internally in master mode). This allows the device to transfer or receive data while in SLEEP mode. Slave mode is entered by clearing bit CSRC (TXSTA<7>).

### 9.4.1 USART SYNCHRONOUS SLAVE TRANSMIT

The operation of the synchronous master and slave modes are identical, except in the case of the SLEEP mode.

If two words are written to the TXREG and then the SLEEP instruction is executed, the following will occur:

- a) The first word will immediately transfer to the TSR register and transmit.
- b) The second word will remain in TXREG register.
- c) Flag bit TXIF will not be set.
- d) When the first word has been shifted out of TSR, the TXREG register will transfer the second word to the TSR and flag bit TXIF will now be set.
- e) If enable bit TXIE is set, the interrupt will wake the chip from SLEEP. If the global interrupt is enabled, the program will branch to the interrupt vector (0004h).

Steps to follow when setting up a Synchronous Slave Transmission:

1. Enable the synchronous slave serial port by setting bits SYNC and SPEN and clearing bit CSRC.
2. Clear bits CREN and SREN.
3. If interrupts are desired, then set enable bit TXIE.
4. If 9-bit transmission is desired, then set bit TX9.
5. Enable the transmission by setting enable bit TXEN.
6. If 9-bit transmission is selected, the ninth bit should be loaded in bit TX9D.
7. Start transmission by loading data to the TXREG register.

### 9.4.2 USART SYNCHRONOUS SLAVE RECEPTION

The operation of the synchronous master and slave modes is identical except in the case of the SLEEP mode and bit SREN, which is a "don't care" in slave mode.

If receive is enabled by setting bit CREN prior to the SLEEP instruction, then a word may be received during SLEEP. On completely receiving the word, the RSR register will transfer the data to the RCREG register and if enable bit RCIE bit is set, the interrupt generated will wake the chip from SLEEP. If the global interrupt is enabled, the program will branch to the interrupt vector (0004h).

Steps to follow when setting up a Synchronous Slave Reception:

1. Enable the synchronous master serial port by setting bits SYNC and SPEN and clearing bit CSRC.
2. If interrupts are desired, then set enable bit RCIE.
3. If 9-bit reception is desired, then set bit RX9.
4. To enable reception, set enable bit CREN.
5. Flag bit RCIF will be set when reception is complete. An interrupt will be generated if enable bit RCIE was set.
6. Read the RCSTA register to get the ninth bit (if enabled) and determine if any error occurred during reception.
7. Read the 8-bit received data by reading the RCREG register.
8. If any error occurred, clear the error by clearing bit CREN.

# PIC16C63A/65B/73B/74B

**TABLE 9-10: REGISTERS ASSOCIATED WITH SYNCHRONOUS SLAVE TRANSMISSION**

Address	Name	Bit 7	Bit 6	Bit 5	Bit 4	Bit 3	Bit 2	Bit 1	Bit 0	Value on POR, BOR	Value on all other Resets
0Ch	PIR1	PSPIF <sup>(1)</sup>	ADIF <sup>(2)</sup>	RCIF	TXIF	SSPIF	CCP1IF	TMR2IF	TMR1IF	0000 0000	0000 0000
18h	RCSTA	SPEN	RX9	SREN	CREN	—	FERR	OERR	RX9D	0000 -00x	0000 -00x
19h	TXREG	USART Transmit Register								0000 0000	0000 0000
8Ch	PIE1	PSPIE <sup>(1)</sup>	ADIE <sup>(2)</sup>	RCIE	TXIE	SSPIE	CCP1IE	TMR2IE	TMR1IE	0000 0000	0000 0000
98h	TXSTA	CSRC	TX9	TXEN	SYNC	—	BRGH	TRMT	TX9D	0000 -010	0000 -010
99h	SPBRG	Baud Rate Generator Register								0000 0000	0000 0000

Legend: x = unknown, - = unimplemented read as '0'. Shaded cells are not used for Synchronous Slave Transmission.

Note 1: Bits PSPIE and PSPIF are reserved on the PIC16C63A/73B. Always maintain these bits clear.

2: Bits ADIE and ADIF are reserved on the PIC16C63A/65B. Always maintain these bits clear.

**TABLE 9-11: REGISTERS ASSOCIATED WITH SYNCHRONOUS SLAVE RECEPTION**

Address	Name	Bit 7	Bit 6	Bit 5	Bit 4	Bit 3	Bit 2	Bit 1	Bit 0	Value on POR, BOR	Value on all other Resets
0Ch	PIR1	PSPIF <sup>(1)</sup>	ADIF <sup>(2)</sup>	RCIF	TXIF	SSPIF	CCP1IF	TMR2IF	TMR1IF	0000 0000	0000 0000
18h	RCSTA	SPEN	RX9	SREN	CREN	—	FERR	OERR	RX9D	0000 -00x	0000 -00x
1Ah	RCREG	USART Receive Register								0000 0000	0000 0000
8Ch	PIE1	PSPIE <sup>(1)</sup>	ADIE <sup>(2)</sup>	RCIE	TXIE	SSPIE	CCP1IE	TMR2IE	TMR1IE	0000 0000	0000 0000
98h	TXSTA	CSRC	TX9	TXEN	SYNC	—	BRGH	TRMT	TX9D	0000 -010	0000 -010
99h	SPBRG	Baud Rate Generator Register								0000 0000	0000 0000

Legend: x = unknown, - = unimplemented read as '0'. Shaded cells are not used for Synchronous Slave Reception.

Note 1: Bits PSPIE and PSPIF are reserved on the PIC16C63A/73B. Always maintain these bits clear.

2: Bits ADIE and ADIF are reserved on the PIC16C63A/65B. Always maintain these bits clear.

# PIC16C63A/65B/73B/74B

## 10.0 ANALOG-TO-DIGITAL CONVERTER (A/D) MODULE

This section applies to the PIC16C73B and PIC16C74B only. The analog-to-digital (A/D) converter module has five inputs for the PIC16C73B, and eight for the PIC16C74B.

The A/D allows conversion of an analog input signal to a corresponding 8-bit digital number (refer to Application Note AN546 for use of A/D Converter). The output of the sample and hold is the input into the converter, which generates the result via successive approximation. The analog reference voltage is software selectable to either the device's positive supply voltage (VDD) or the voltage level on the RA3/AN3/VREF pin.

The A/D converter has a unique feature of being able to operate while the device is in SLEEP mode. To operate in sleep, the A/D conversion clock must be derived from the A/D's internal RC oscillator.

Additional information on the A/D module is available in the PICmicro™ Mid-Range Reference Manual, (DS33023).

The A/D module has three registers. These registers are:

- A/D Result Register (ADRES)
- A/D Control Register 0 (ADCON0)
- A/D Control Register 1 (ADCON1)

A device reset forces all registers to their reset state. This forces the A/D module to be turned off and any conversion is aborted.

The ADCON0 register, shown in Figure 10-1, controls the operation of the A/D module. The ADCON1 register, shown in Figure 10-2, configures the functions of the port pins. The port pins can be configured as analog inputs (RA3 can also be a voltage reference) or as digital I/O.

**FIGURE 10-1: ADCON0 REGISTER (ADDRESS 1Fh)**

R/W-0	R/W-0	R/W-0	R/W-0	R/W-0	R/W-0	U-0	R/W-0
ADCS1	ADCS0	CHS2	CHS1	CHS0	GO/DONE	—	ADON
						bit0	
<p>bit 7-6: <b>ADCS1:ADCS0:</b> A/D Conversion Clock Select bits            00 = Fosc/2            01 = Fosc/8            10 = Fosc/32            11 = FRC (clock derived from an internal RC oscillator)</p> <p>bit 5-3: <b>CHS2:CHS0:</b> Analog Channel Select bits            000 = channel 0, (RA0/AN0)            001 = channel 1, (RA1/AN1)            010 = channel 2, (RA2/AN2)            011 = channel 3, (RA3/AN3)            100 = channel 4, (RA5/AN4)</p> <p>bit 2: <b>GO/DONE:</b> A/D Conversion Status bit            If ADON = 1            1 = A/D conversion in progress (setting this bit starts the A/D conversion)            0 = A/D conversion not in progress (This bit is automatically cleared by hardware when the A/D conversion is complete)</p> <p>bit 1: <b>Unimplemented:</b> Read as '0'</p> <p>bit 0: <b>ADON:</b> A/D On bit            1 = A/D converter module is operating            0 = A/D converter module is shutoff and consumes no operating current</p>							

R = Readable bit  
 W = Writable bit  
 U = Unimplemented bit, read as '0'  
 - n = Value at POR reset

# PIC16C63A/65B/73B/74B

FIGURE 10-2: ADCON1 REGISTER (ADDRESS 9Fh)

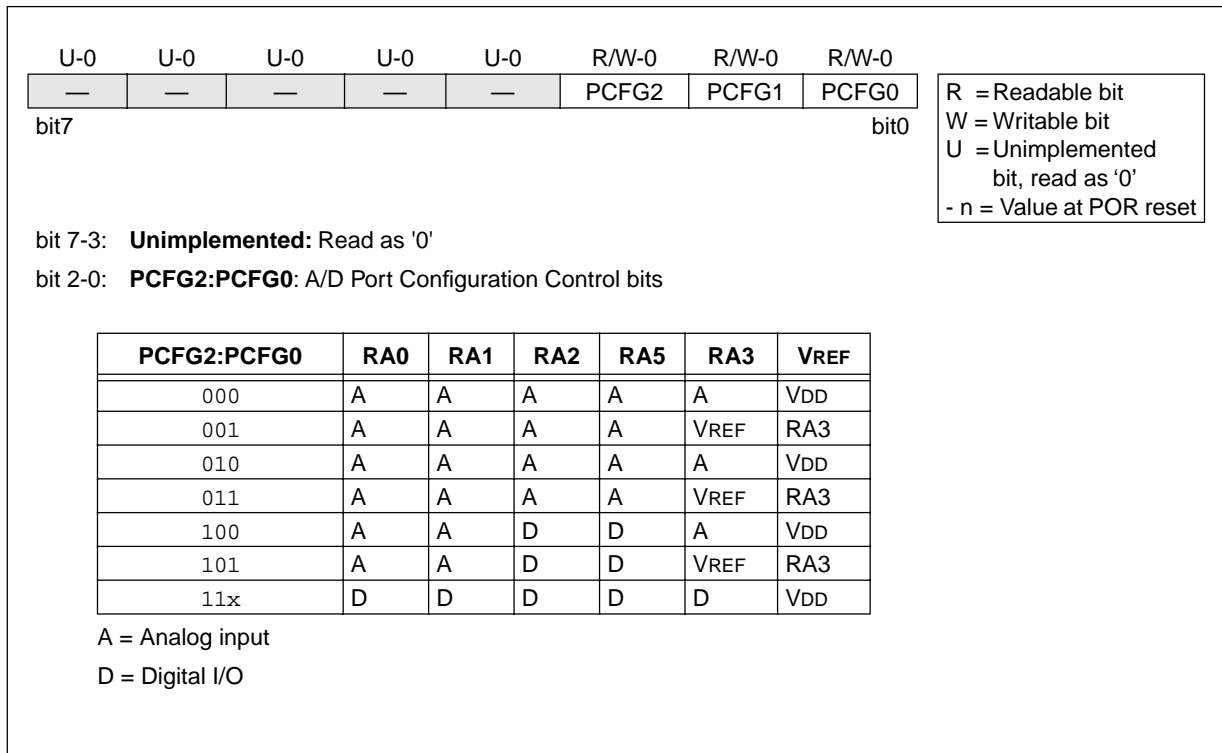

# PIC16C63A/65B/73B/74B

The ADRES register contains the result of the A/D conversion. When the A/D conversion is complete, the result is loaded into the ADRES register, the GO/DONE bit (ADCON0<2>) is cleared, and A/D interrupt flag bit ADIF is set. The block diagram of the A/D module is shown in Figure 10-3.

The value that is in the ADRES register is not modified for a Power-on Reset. The ADRES register will contain unknown data after a Power-on Reset.

After the A/D module has been configured as desired, the selected channel must be acquired before the conversion is started. The analog input channels must have their corresponding TRIS bits selected as an input. To determine acquisition time, see Section 10.1. After this acquisition time has elapsed the A/D conversion can be started. The following steps should be followed for doing an A/D conversion:

1. Configure the A/D module:
  - Configure analog pins / voltage reference / and digital I/O (ADCON1)
  - Select A/D input channel (ADCON0)
  - Select A/D conversion clock (ADCON0)
  - Turn on A/D module (ADCON0)
2. Configure A/D interrupt (if desired):
  - Clear ADIF bit
  - Set ADIE bit
  - Set GIE bit
3. Wait the required acquisition time.
4. Start conversion:
  - Set GO/DONE bit (ADCON0)
5. Wait for A/D conversion to complete, by either:
  - Polling for the GO/DONE bit to be cleared
  - OR
  - Waiting for the A/D interrupt
6. Read A/D Result register (ADRES), clear bit ADIF if required.
7. For next conversion, go to step 1 or step 2 as required. The A/D conversion time per bit is defined as TAD. A minimum wait of 2TAD is required before next acquisition starts.

**FIGURE 10-3: A/D BLOCK DIAGRAM**

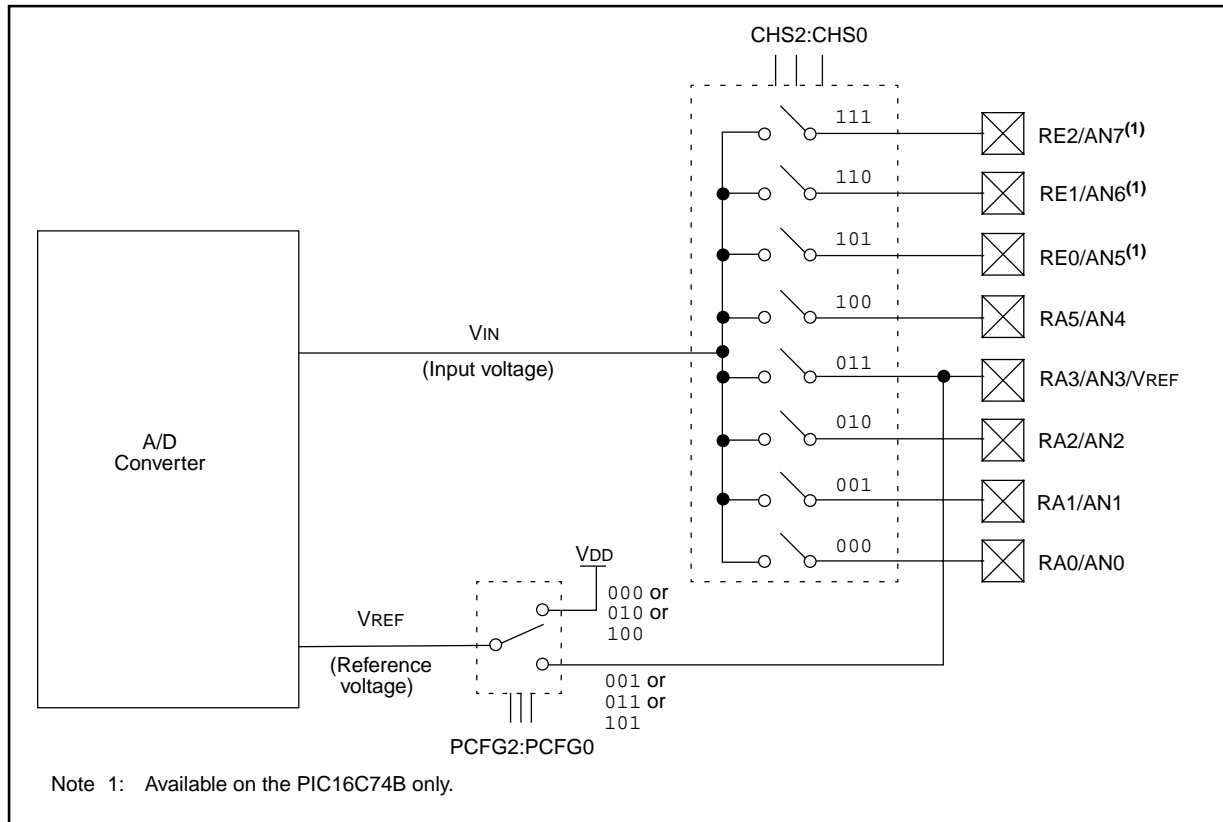

# PIC16C63A/65B/73B/74B

## 10.1 A/D Acquisition Requirements

For the A/D converter to meet its specified accuracy, the charge holding capacitor (CHOLD) must be allowed to fully charge to the input channel voltage level. The analog input model is shown in Figure 10-4. The source impedance ( $R_S$ ) and the internal sampling switch ( $R_{SS}$ ) impedance directly affect the time required to charge the capacitor CHOLD. The sampling switch ( $R_{SS}$ ) impedance varies over the device voltage ( $V_{DD}$ ). The source impedance affects the offset voltage at the analog input (due to pin leakage current). **The maximum recommended impedance for analog sources is 10 k $\Omega$ .** After the analog input channel is selected (changed) this acquisition must be done before the conversion can be started.

To calculate the minimum acquisition time,  $T_{ACQ}$ , see the PICmicro™ Mid-Range Reference Manual, (DS33023). This equation calculates the acquisition time to within 1/2 LSb error (512 steps for the A/D). The 1/2 LSb error is the maximum error allowed for the A/D to meet its specified accuracy.

**Note:** When the conversion is started, the holding capacitor is disconnected from the input pin.

**FIGURE 10-4: ANALOG INPUT MODEL**

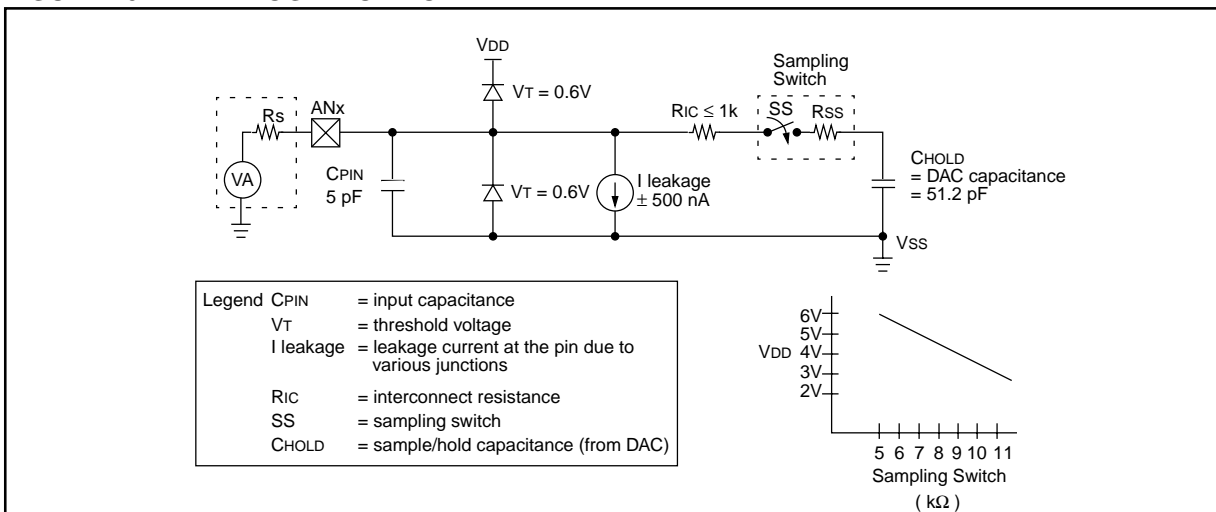

# PIC16C63A/65B/73B/74B

## 10.2 Selecting the A/D Conversion Clock

The A/D conversion time per bit is defined as TAD. The A/D conversion requires 9.5TAD per 8-bit conversion. The source of the A/D conversion clock is software selectable. The four possible options for TAD are:

- 2Tosc
- 8Tosc
- 32Tosc
- Internal RC oscillator

For correct A/D conversions, the A/D conversion clock (TAD) must be selected to ensure a minimum TAD time of 1.6  $\mu$ s.

Table 10-1 shows the resultant TAD times derived from the device operating frequencies and the A/D clock source selected.

## 10.3 Configuring Analog Port Pins

The ADCON1, TRISA, and TRISE registers control the operation of the A/D port pins. The port pins that are desired as analog inputs must have their corresponding TRIS bits set (input). If the TRIS bit is cleared (output), the digital output level (VOH or VOL) will be converted.

The A/D operation is independent of the state of the CHS2:CHS0 bits and the TRIS bits.

**Note 1:** When reading the port register, all pins configured as analog input channels will read as cleared (a low level). Pins configured as digital inputs, will convert an analog input. Analog levels on a digitally configured input will not affect the conversion accuracy.

**Note 2:** Analog levels on any pin that is defined as a digital input (including the AN4:AN0 pins) may cause the input buffer to consume current that is out of the devices specification.

**TABLE 10-1: TAD vs. DEVICE OPERATING FREQUENCIES**

AD Clock Source (TAD)		Device Frequency			
Operation	ADCS1:ADCS0	20 MHz	5 MHz	1.25 MHz	333.33 kHz
2Tosc	00	100 ns <sup>(2)</sup>	400 ns <sup>(2)</sup>	1.6 $\mu$ s	6 $\mu$ s
8Tosc	01	400 ns <sup>(2)</sup>	1.6 $\mu$ s	6.4 $\mu$ s	24 $\mu$ s <sup>(3)</sup>
32Tosc	10	1.6 $\mu$ s	6.4 $\mu$ s	25.6 $\mu$ s <sup>(3)</sup>	96 $\mu$ s <sup>(3)</sup>
RC <sup>(5)</sup>	11	2 - 6 $\mu$ s <sup>(1,4)</sup>	2 - 6 $\mu$ s <sup>(1,4)</sup>	2 - 6 $\mu$ s <sup>(1,4)</sup>	2 - 6 $\mu$ s <sup>(1)</sup>

Legend: Shaded cells are outside of recommended range.

Note 1: The RC source has a typical TAD time of 4  $\mu$ s.

2: These values violate the minimum required TAD time.

3: For faster conversion times, the selection of another clock source is recommended.

4: When device frequency is greater than 1 MHz, the RC A/D conversion clock source is recommended for sleep operation only.

5: For extended voltage devices (LC), please refer to Electrical Specifications section.

# PIC16C63A/65B/73B/74B

## 10.4 A/D Conversions

**Note:** The GO/DONE bit should **NOT** be set in the same instruction that turns on the A/D.

## 10.5 Use of the CCP Trigger

An A/D conversion can be started by the “special event trigger” of the CCP2 module. This requires that the CCP2M3:CCP2M0 bits (CCP2CON<3:0>) be programmed as 1011 and that the A/D module is enabled (ADON bit is set). When the trigger occurs, the

GO/DONE bit will be set, starting the A/D conversion, and the Timer1 counter will be reset to zero. Timer1 is reset to automatically repeat the A/D acquisition period with minimal software overhead (moving the ADRES to the desired location). The appropriate analog input channel must be selected and the minimum acquisition done before the “special event trigger” sets the GO/DONE bit (starts a conversion).

If the A/D module is not enabled (ADON is cleared), then the “special event trigger” will be ignored by the A/D module, but will still reset the Timer1 counter.

**TABLE 10-2: SUMMARY OF A/D REGISTERS**

Address	Name	Bit 7	Bit 6	Bit 5	Bit 4	Bit 3	Bit 2	Bit 1	Bit 0	Value on POR, BOR	Value on all other Resets
0Bh,8Bh	INTCON	GIE	PEIE	T0IE	INTE	RBIE	T0IF	INTF	RBIF	0000 000x	0000 000u
0Ch	PIR1	PSPIF <sup>(1)</sup>	ADIF	RCIF	TXIF	SSPIF	CCP1IF	TMR2IF	TMR1IF	0000 0000	0000 0000
8Ch	PIE1	PSPIE <sup>(1)</sup>	ADIE	RCIE	TXIE	SSPIE	CCP1IE	TMR2IE	TMR1IE	0000 0000	0000 0000
0Dh	PIR2	—	—	—	—	—	—	—	CCP2IF	---- --0	---- --0
8Dh	PIE2	—	—	—	—	—	—	—	CCP2IE	---- --0	---- --0
1Eh	ADRES	A/D Result Register								xxxx xxxx	uuuu uuuu
1Fh	ADCON0	ADCS1	ADCS0	CHS2	CHS1	CHS0	GO/DONE	—	ADON	0000 00-0	0000 00-0
9Fh	ADCON1	—	—	—	—	—	PCFG2	PCFG1	PCFG0	---- -000	---- -000
05h	PORTA	—	—	RA5	RA4	RA3	RA2	RA1	RA0	--0x 0000	--0u 0000
85h	TRISA	—	—	PORTA Data Direction Register						--11 1111	--11 1111
09h	PORTE	—	—	—	—	—	RE2	RE1	RE0	---- -xxx	---- -uuu
89h	TRISE	IBF	OBF	IBOV	PSPMODE	—	PORTE Data Direction Bits			0000 -111	0000 -111

Legend: x = unknown, u = unchanged, - = unimplemented read as '0'. Shaded cells are not used for A/D conversion.

Note 1: Bits PSPIE and PSPIF are reserved on the PIC6C73B. Always maintain these bits clear.



# PIC16C63A/65B/73B/74B

## 11.0 SPECIAL FEATURES OF THE CPU

The PIC16C63A/65B/73B/74B devices have a host of features intended to maximize system reliability, minimize cost through elimination of external components, provide power saving operating modes and offer code protection. These are:

- OSC Selection
- Reset
  - Power-on Reset (POR)
  - Power-up Timer (PWRT)
  - Oscillator Start-up Timer (OST)
  - Brown-out Reset (BOR)
- Interrupts
- Watchdog Timer (WDT)
- SLEEP
- Code protection
- ID locations
- In-circuit serial programming

These devices have a Watchdog Timer which can be shut off only through configuration bits. It runs off its own RC oscillator for added reliability. There are two timers that offer necessary delays on power-up. One is the Oscillator Start-up Timer (OST), intended to keep the chip in reset until the crystal oscillator is stable. The

other is the Power-up Timer (PWRT), which provides a fixed delay on power-up only, designed to keep the part in reset while the power supply stabilizes. With these two timers on-chip, most applications need no external reset circuitry.

SLEEP mode is designed to offer a very low current power-down mode. The user can wake-up from SLEEP through external reset, Watchdog Timer Wake-up or through an interrupt. Several oscillator options are also made available to allow the part to fit the application. The RC oscillator option saves system cost, while the LP crystal option saves power. A set of configuration bits are used to select various options.

Additional information on special features is available in the PICmicro™ Mid-Range Reference Manual, (DS33023).

### 11.1 Configuration Bits

The configuration bits can be programmed (read as '0') or left unprogrammed (read as '1') to select various device configurations. These bits are mapped in program memory location 2007h.

The user will note that address 2007h is beyond the user program memory space. In fact, it belongs to the special test/configuration memory space (2000h - 3FFFh), which can be accessed only during programming.

**FIGURE 11-1: CONFIGURATION WORD**

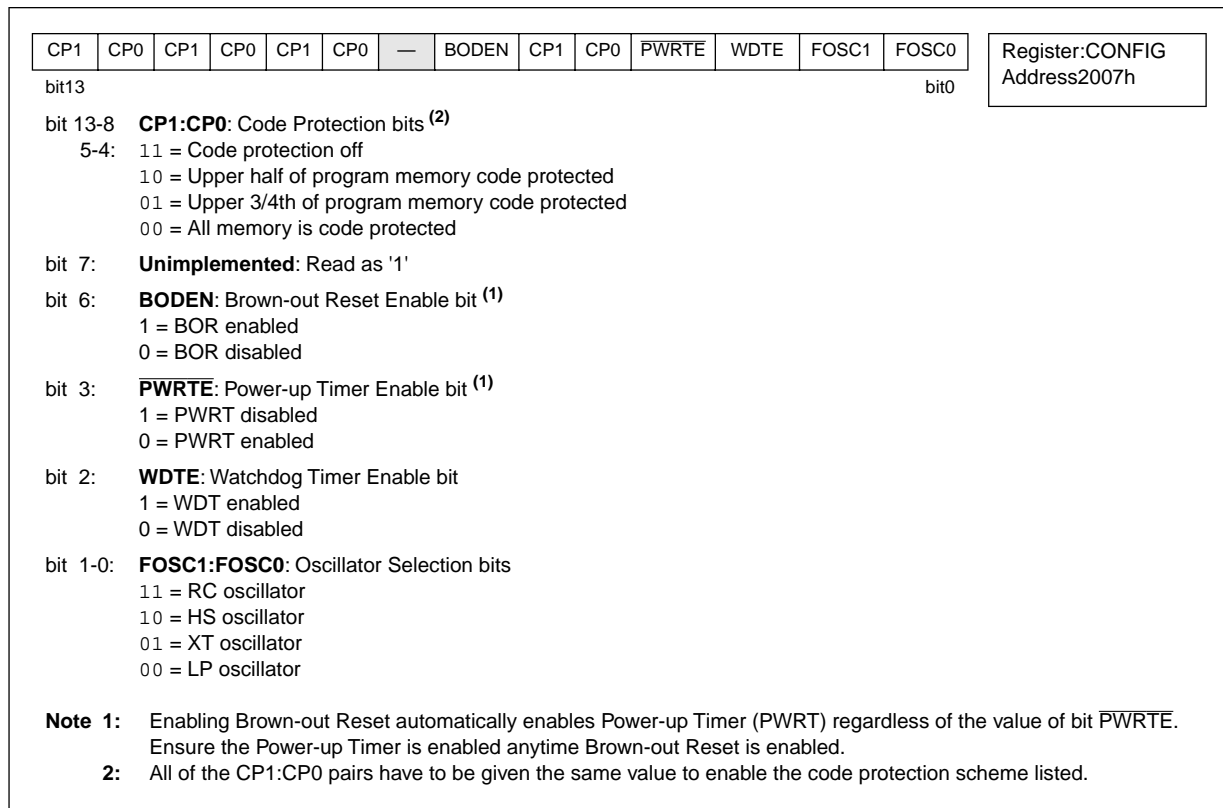

# PIC16C63A/65B/73B/74B

## 11.2 Oscillator Configurations

### 11.2.1 OSCILLATOR TYPES

The PIC16CXXX can be operated in four different oscillator modes. The user can program two configuration bits (FOSC1 and FOSC0) to select one of these four modes:

- LP Low Power Crystal
- XT Crystal/Resonator
- HS High Speed Crystal/Resonator
- RC Resistor/Capacitor

### 11.2.2 CRYSTAL OSCILLATOR/CERAMIC RESONATORS

In XT, LP or HS modes a crystal or ceramic resonator is connected to the OSC1/CLKIN and OSC2/CLKOUT pins to establish oscillation (Figure 11-2). The PIC16CXXX oscillator design requires the use of a parallel cut crystal. Use of a series cut crystal may give a frequency out of the crystal manufacturers specifications. When in XT, LP or HS modes, the device can have an external clock source to drive the OSC1/CLKIN pin (Figure 11-3).

**FIGURE 11-2: CRYSTAL/CERAMIC RESONATOR OPERATION (HS, XT OR LP OSC CONFIGURATION)**

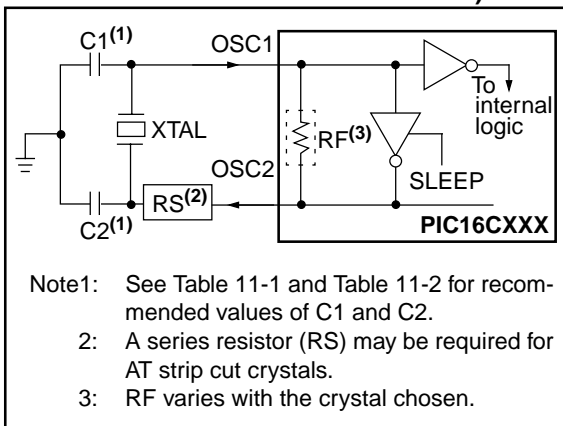

**FIGURE 11-3: EXTERNAL CLOCK INPUT OPERATION (HS, XT OR LP OSC CONFIGURATION)**

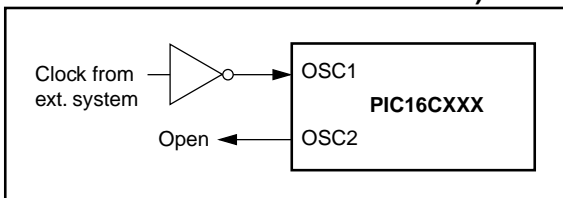

**TABLE 11-1: CERAMIC RESONATORS**

Ranges Tested:			
Mode	Freq	OSC1	OSC2
XT	455 kHz	68 - 100 pF	68 - 100 pF
	2.0 MHz	15 - 68 pF	15 - 68 pF
	4.0 MHz	15 - 68 pF	15 - 68 pF
HS	8.0 MHz	10 - 68 pF	10 - 68 pF
	16.0 MHz	10 - 22 pF	10 - 22 pF
These values are for design guidance only. See notes at bottom of page.			
Resonators Used:			
455 kHz	Panasonic EFO-A455K04B	± 0.3%	
2.0 MHz	Murata Erie CSA2.00MG	± 0.5%	
4.0 MHz	Murata Erie CSA4.00MG	± 0.5%	
8.0 MHz	Murata Erie CSA8.00MT	± 0.5%	
16.0 MHz	Murata Erie CSA16.00MX	± 0.5%	
All resonators used did not have built-in capacitors.			

**TABLE 11-2: CAPACITOR SELECTION FOR CRYSTAL OSCILLATOR**

Osc Type	Crystal Freq	Cap. Range C1	Cap. Range C2
LP	32 kHz	33 pF	33 pF
	200 kHz	15 pF	15 pF
XT	200 kHz	47-68 pF	47-68 pF
	1 MHz	15 pF	15 pF
	4 MHz	15 pF	15 pF
HS	4 MHz	15 pF	15 pF
	8 MHz	15-33 pF	15-33 pF
	20 MHz	15-33 pF	15-33 pF
These values are for design guidance only. See notes at bottom of page.			
Crystals Used			
32 kHz	Epson C-001R32.768K-A	± 20 PPM	
200 kHz	STD XTL 200.000KHz	± 20 PPM	
1 MHz	ECS ECS-10-13-1	± 50 PPM	
4 MHz	ECS ECS-40-20-1	± 50 PPM	
8 MHz	EPSON CA-301 8.000M-C	± 30 PPM	
20 MHz	EPSON CA-301 20.000M-C	± 30 PPM	

- Note 1: Recommended values of C1 and C2 are identical to the ranges tested (Table 11-1).  
 2: Higher capacitance increases the stability of oscillator but also increases the start-up time.  
 3: Since each resonator/crystal has its own characteristics, the user should consult the resonator/crystal manufacturer for appropriate values of external components.  
 4: Rs may be required in HS mode, as well as XT mode, to avoid overdriving crystals with low drive level specification.

# PIC16C63A/65B/73B/74B

## 11.2.3 RC OSCILLATOR

For timing insensitive applications, the "RC" device option offers additional cost savings. The RC oscillator frequency is a function of the supply voltage, the resistor (R<sub>EXT</sub>) and capacitor (C<sub>EXT</sub>) values and the operating temperature. In addition to this, the oscillator frequency will vary from unit to unit due to normal process parameter variation. Furthermore, the difference in lead frame capacitance between package types will also affect the oscillation frequency, especially for low C<sub>EXT</sub> values. The user also needs to take into account variation due to tolerance of external R and C components used. Figure 11-4 shows how the R/C combination is connected to the PIC16CXXX.

**FIGURE 11-4: RC OSCILLATOR MODE**

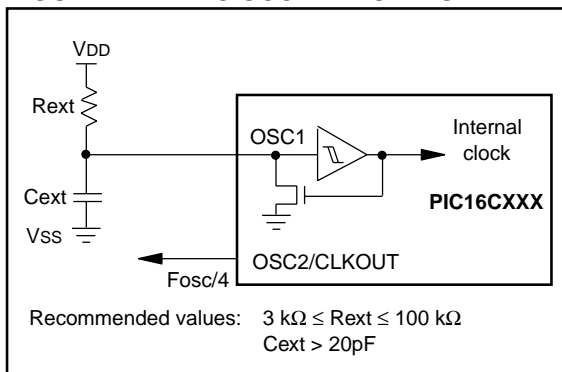

## 11.3 Reset

The PIC16CXXX differentiates between various kinds of reset:

- Power-on Reset (POR)
- $\overline{\text{MCLR}}$  reset during normal operation
- $\overline{\text{MCLR}}$  reset during SLEEP
- WDT Reset (during normal operation)
- WDT Wake-up (during SLEEP)
- Brown-out Reset (BOR)

Some registers are not affected in any reset condition. Their status is unknown on POR and unchanged in any other reset. Most other registers are reset to a "reset state" on Power-on Reset (POR), on the  $\overline{\text{MCLR}}$  and WDT Reset, on  $\overline{\text{MCLR}}$  reset during SLEEP and Brown-out Reset (BOR). They are not affected by a WDT Wake-up, which is viewed as the resumption of normal operation. The  $\overline{\text{TO}}$  and  $\overline{\text{PD}}$  bits are set or cleared differently in different reset situations as indicated in Table 11-4. These bits are used in software to determine the nature of the reset. See Table 11-6 for a full description of reset states of all registers.

A simplified block diagram of the on-chip reset circuit is shown in Figure 11-5.

The PICmicros have a  $\overline{\text{MCLR}}$  noise filter in the  $\overline{\text{MCLR}}$  reset path. The filter will detect and ignore small pulses.

It should be noted that a WDT Reset does not drive  $\overline{\text{MCLR}}$  pin low.

# PIC16C63A/65B/73B/74B

FIGURE 11-5: SIMPLIFIED BLOCK DIAGRAM OF ON-CHIP RESET CIRCUIT

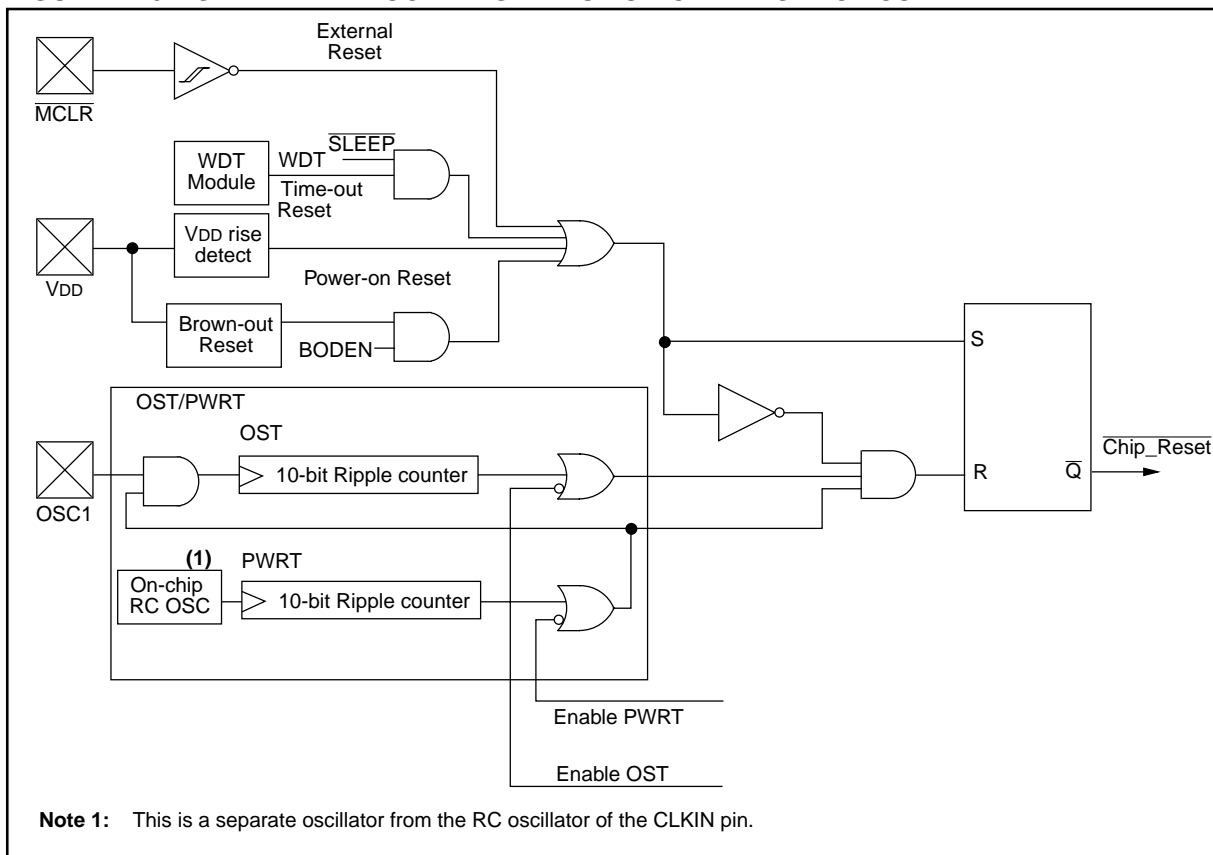

## 11.4 Power-On Reset (POR)

A Power-on Reset pulse is generated on-chip when VDD rise is detected (in the range of 1.5V - 2.1V). To take advantage of the POR, just tie the  $\overline{\text{MCLR}}$  pin directly (or through a resistor) to VDD. This will eliminate external RC components usually needed to create a Power-on Reset. A maximum rise time for VDD is specified (parameter D004). For a slow rise time, see Figure 11-6.

When the device starts normal operation (exits the reset condition), device operating parameters (voltage, frequency, temperature,...) must be met to ensure operation. If these conditions are not met, the device must be held in reset until the operating conditions are met. Brown-out Reset may be used to meet the start-up conditions.

**FIGURE 11-6: EXTERNAL POWER-ON RESET CIRCUIT (FOR SLOW VDD POWER-UP)**

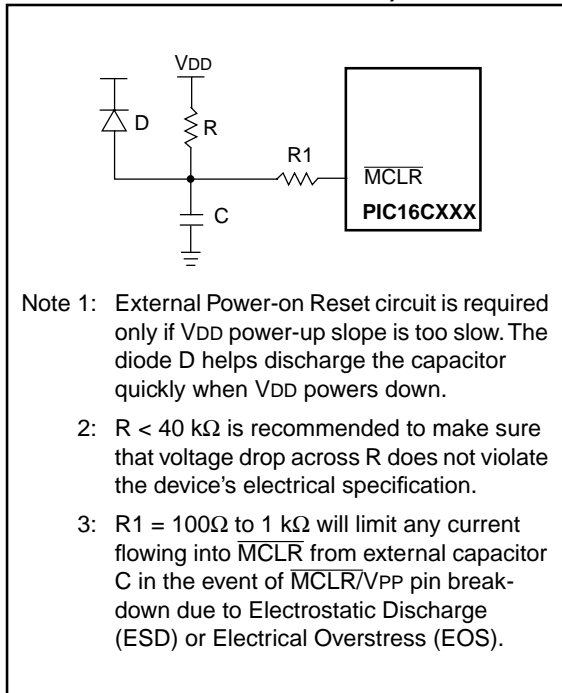

## 11.5 Power-up Timer (PWRT)

The Power-up Timer provides a fixed nominal time-out (parameter #33) on power-up only, from the POR. The Power-up Timer operates on an internal RC oscillator. The chip is kept in reset as long as the PWRT is active. The PWRT's time delay allows VDD to rise to an acceptable level. A configuration bit is provided to enable/disable the PWRT.

The power-up time delay will vary from chip to chip due to VDD, temperature and process variation. See DC parameters for details.

## 11.6 Oscillator Start-up Timer (OST)

The Oscillator Start-up Timer (OST) provides 1024 oscillator cycle (from OSC1 input) delay after the PWRT delay is over (parameter #32). This ensures that the crystal oscillator or resonator has started and stabilized.

The OST time-out is invoked only for XT, LP and HS modes and only on Power-on Reset or wake-up from SLEEP.

## 11.7 Brown-Out Reset (BOR)

A configuration bit, BODEN, can disable (if clear/programmed) or enable (if set) the Brown-out Reset circuitry. If VDD falls below parameter D005 for greater than parameter #35, the brown-out situation will reset the chip. A reset may not occur if VDD falls below parameter D005 for less than parameter #35. The chip will remain in Brown-out Reset until VDD rises above BVDD. The Power-up Timer will then be invoked and will keep the chip in RESET an additional time delay (parameter #33). If VDD drops below BVDD while the Power-up Timer is running, the chip will go back into a Brown-out Reset and the Power-up Timer will be initialized. Once VDD rises above BVDD, the Power-up Timer will execute the additional time delay. The Power-up Timer should always be enabled when Brown-out Reset is enabled.

# PIC16C63A/65B/73B/74B

## 11.8 Time-out Sequence

On power-up, the time-out sequence is as follows: First PWRT time-out is invoked after the POR time delay has expired. Then OST is activated. The total time-out will vary based on oscillator configuration and the status of the PWRT. For example, in RC mode with the PWRT disabled, there will be no time-out at all. Figure 11-7, Figure 11-8, Figure 11-9 and Figure 11-10 depict time-out sequences on power-up.

Since the time-outs occur from the POR pulse, if  $\overline{\text{MCLR}}$  is kept low long enough, the time-outs will expire. Then bringing  $\overline{\text{MCLR}}$  high will begin execution immediately (Figure 11-9). This is useful for testing purposes or to synchronize more than one PIC16CXXX device operating in parallel.

Table 11-5 shows the reset conditions for some special function registers, while Table 11-6 shows the reset conditions for all the registers.

## 11.9 Power Control/Status Register (PCON)

The Power Control/Status Register, PCON, has up to two bits, depending upon the device.

Bit0 is Brown-out Reset Status bit,  $\overline{\text{BOR}}$ . If the BODEN configuration bit is set, BOR is '1' on Power-on Reset. If the BODEN configuration bit is clear, BOR is unknown on Power-on Reset.

The  $\overline{\text{BOR}}$  status bit is a "don't care" and is not necessarily predictable if the brown-out circuit is disabled (the BODEN configuration bit is clear).  $\overline{\text{BOR}}$  must then be set by the user and checked on subsequent resets to see if it is clear, indicating a brown-out has occurred.

Bit1 is  $\overline{\text{POR}}$  (Power-on Reset Status bit). It is cleared on a Power-on Reset and unaffected otherwise. The user must set this bit following a Power-on Reset.

**TABLE 11-3: TIME-OUT IN VARIOUS SITUATIONS**

Oscillator Configuration	Power-up		Brown-out	Wake-up from SLEEP
	PWRTE = 0	PWRTE = 1		
XT, HS, LP	72 ms + 1024Tosc	1024Tosc	72 ms + 1024Tosc	1024Tosc
RC	72 ms	—	72 ms	—

**TABLE 11-4: STATUS BITS AND THEIR SIGNIFICANCE**

POR	BOR	$\overline{\text{TO}}$	$\overline{\text{PD}}$	
0	x	1	1	Power-on Reset
0	x	0	x	Illegal, $\overline{\text{TO}}$ is set on $\overline{\text{POR}}$
0	x	x	0	Illegal, $\overline{\text{PD}}$ is set on $\overline{\text{POR}}$
1	0	1	1	Brown-out Reset
1	1	0	1	WDT Reset
1	1	0	0	WDT Wake-up
1	1	u	u	$\overline{\text{MCLR}}$ Reset during normal operation
1	1	1	0	$\overline{\text{MCLR}}$ Reset during SLEEP or interrupt wake-up from SLEEP

**TABLE 11-5: RESET CONDITION FOR SPECIAL REGISTERS**

Condition	Program Counter	STATUS Register	PCON Register
Power-on Reset	000h	0001 1xxx	---- --0x
$\overline{\text{MCLR}}$ Reset during normal operation	000h	000u uuuu	---- --uu
$\overline{\text{MCLR}}$ Reset during SLEEP	000h	0001 0uuu	---- --uu
WDT Reset	000h	0000 1uuu	---- --uu
WDT Wake-up	PC + 1	uuu0 0uuu	---- --uu
Brown-out Reset	000h	0001 1uuu	---- --u0
Interrupt wake-up from SLEEP	PC + 1 <sup>(1)</sup>	uuu1 0uuu	---- --uu

Legend: u = unchanged, x = unknown, - = unimplemented bit read as '0'.

Note 1: When the wake-up is due to an interrupt and the GIE bit is set, the PC is loaded with the interrupt vector (0004h).

# PIC16C63A/65B/73B/74B

**TABLE 11-6: INITIALIZATION CONDITIONS FOR ALL REGISTERS**

Register	Applicable Devices				Power-on Reset, Brown-out Reset	MCLR Resets WDT Reset	Wake-up via WDT or Interrupt
	63A	65B	73B	74B			
W	63A	65B	73B	74B	xxxx xxxx	uuuu uuuu	uuuu uuuu
INDF	63A	65B	73B	74B	N/A	N/A	N/A
TMR0	63A	65B	73B	74B	xxxx xxxx	uuuu uuuu	uuuu uuuu
PCL	63A	65B	73B	74B	0000h	0000h	PC + 1 <sup>(2)</sup>
STATUS	63A	65B	73B	74B	0001 1xxxx	000q quuu <sup>(3)</sup>	uuuq quuu <sup>(3)</sup>
FSR	63A	65B	73B	74B	xxxx xxxx	uuuu uuuu	uuuu uuuu
PORTA <sup>(4)</sup>	63A	65B	73B	74B	--0x 0000	--0u 0000	--uu uuuu
PORTB <sup>(5)</sup>	63A	65B	73B	74B	xxxx xxxx	uuuu uuuu	uuuu uuuu
PORTC <sup>(5)</sup>	63A	65B	73B	74B	xxxx xxxx	uuuu uuuu	uuuu uuuu
PORTD <sup>(5)</sup>	63A	65B	73B	74B	xxxx xxxx	uuuu uuuu	uuuu uuuu
PORTE <sup>(5)</sup>	63A	65B	73B	74B	---- -xxx	---- -uuu	---- -uuu
PCLATH	63A	65B	73B	74B	---0 0000	---0 0000	---u uuuu
INTCON	63A	65B	73B	74B	0000 000x	0000 000u	uuuu uuuu <sup>(1)</sup>
PIR1	63A	65B	73B	74B	--00 0000	--00 0000	--uu uuuu <sup>(1)</sup>
	63A	65B	73B	74B	-000 0000	-000 0000	-uuu uuuu <sup>(1)</sup>
	63A	65B	73B	74B	0-00 0000	0-00 0000	u-uu uuuu <sup>(1)</sup>
	63A	65B	73B	74B	0000 0000	0000 0000	uuuu uuuu <sup>(1)</sup>
PIR2	63A	65B	73B	74B	---- --0	---- --0	---- --u <sup>(1)</sup>
TMR1L	63A	65B	73B	74B	xxxx xxxx	uuuu uuuu	uuuu uuuu
TMR1H	63A	65B	73B	74B	xxxx xxxx	uuuu uuuu	uuuu uuuu
T1CON	63A	65B	73B	74B	--00 0000	--uu uuuu	--uu uuuu
TMR2	63A	65B	73B	74B	0000 0000	0000 0000	uuuu uuuu
T2CON	63A	65B	73B	74B	-000 0000	-000 0000	-uuu uuuu
SSPBUF	63A	65B	73B	74B	xxxx xxxx	uuuu uuuu	uuuu uuuu
SSPCON	63A	65B	73B	74B	0000 0000	0000 0000	uuuu uuuu
CCPR1L	63A	65B	73B	74B	xxxx xxxx	uuuu uuuu	uuuu uuuu
CCPR1H	63A	65B	73B	74B	xxxx xxxx	uuuu uuuu	uuuu uuuu
CCP1CON	63A	65B	73B	74B	--00 0000	--00 0000	--uu uuuu
RCSTA	63A	65B	73B	74B	0000 -00x	0000 -00x	uuuu -uuu
TXREG	63A	65B	73B	74B	0000 0000	0000 0000	uuuu uuuu
RCREG	63A	65B	73B	74B	0000 0000	0000 0000	uuuu uuuu
CCPR2L	63A	65B	73B	74B	xxxx xxxx	uuuu uuuu	uuuu uuuu
CCPR2H	63A	65B	73B	74B	xxxx xxxx	uuuu uuuu	uuuu uuuu
CCP2CON	63A	65B	73B	74B	0000 0000	0000 0000	uuuu uuuu

Legend: u = unchanged, x = unknown, - = unimplemented bit, read as '0', q = value depends on condition

Note 1: One or more bits in INTCON, PIR1 and/or PIR2 will be affected (to cause wake-up).

2: When the wake-up is due to an interrupt and the GIE bit is set, the PC is loaded with the interrupt vector (0004h).

3: See Table 11-5 for reset value for specific condition.

4: On any device reset, these pins are configured as inputs.

5: This is the value that will be in the port output latch.

# PIC16C63A/65B/73B/74B

**TABLE 11-6: INITIALIZATION CONDITIONS FOR ALL REGISTERS (Cont'd)**

Register	Applicable Devices				Power-on Reset, Brown-out Reset	MCLR Resets WDT Reset	Wake-up via WDT or Interrupt
	63A	65B	73B	74B			
ADRES	63A	65B	73B	74B	xxxx xxxx	uuuu uuuu	uuuu uuuu
ADCON0	63A	65B	73B	74B	0000 00-0	0000 00-0	uuuu uu-u
OPTION_REG	63A	65B	73B	74B	1111 1111	1111 1111	uuuu uuuu
TRISA	63A	65B	73B	74B	--11 1111	--11 1111	--uu uuuu
TRISB	63A	65B	73B	74B	1111 1111	1111 1111	uuuu uuuu
TRISC	63A	65B	73B	74B	1111 1111	1111 1111	uuuu uuuu
TRISD	63A	65B	73B	74B	1111 1111	1111 1111	uuuu uuuu
TRISE	63A	65B	73B	74B	0000 -111	0000 -111	uuuu -uuu
	63A	65B	73B	74B	0000 -000	0000 -000	uuuu -uuu
PIE1	63A	65B	73B	74B	--00 0000	--00 0000	--uu uuuu
	63A	65B	73B	74B	0-00 0000	0-00 0000	u-uu uuuu
	63A	65B	73B	74B	-000 0000	-000 0000	-uuu uuuu
	63A	65B	73B	74B	0000 0000	0000 0000	uuuu uuuu
PIE2	63A	65B	73B	74B	---- ---0	---- ---0	---- ---u
PCON	63A	65B	73B	74B	---- --0q	---- --uq	---- --uq
PR2	63A	65B	73B	74B	1111 1111	1111 1111	1111 1111
SSPADD	63A	65B	73B	74B	0000 0000	0000 0000	uuuu uuuu
SSPSTAT	63A	65B	73B	74B	0000 0000	0000 0000	uuuu uuuu
TXSTA	63A	65B	73B	74B	0000 -010	0000 -010	uuuu -uuu
SPBRG	63A	65B	73B	74B	0000 0000	0000 0000	uuuu uuuu
ADCON1	63A	65B	73B	74B	---- -000	---- -000	---- -uuu

Legend: u = unchanged, x = unknown, - = unimplemented bit, read as '0', q = value depends on condition

Note 1: One or more bits in INTCON, PIR1 and/or PIR2 will be affected (to cause wake-up).

2: When the wake-up is due to an interrupt and the GIE bit is set, the PC is loaded with the interrupt vector (0004h).

3: See Table 11-5 for reset value for specific condition.

4: On any device reset, these pins are configured as inputs.

5: This is the value that will be in the port output latch.

**FIGURE 11-7: TIME-OUT SEQUENCE ON POWER-UP (MCLR TIED TO VDD)**

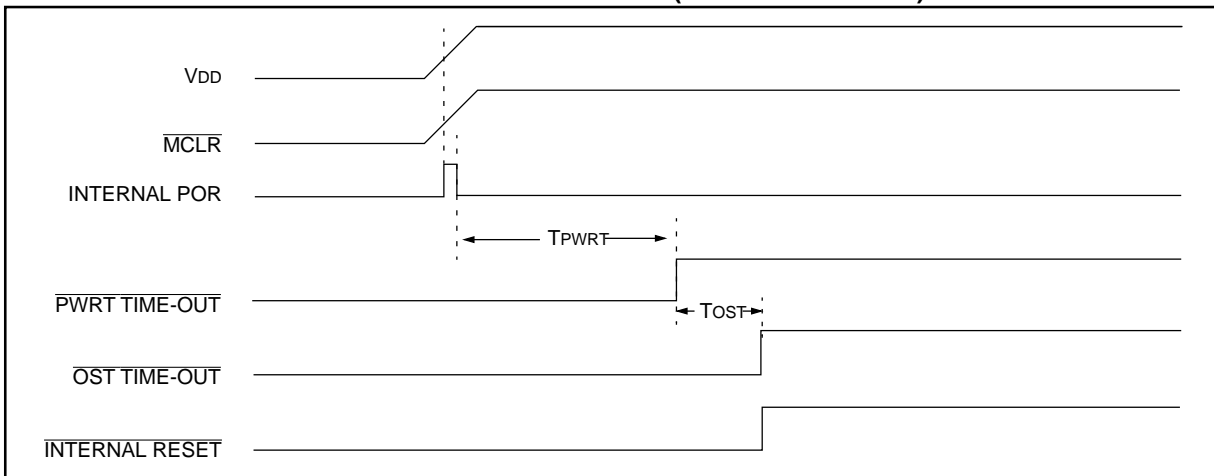



# PIC16C63A/65B/73B/74B

**FIGURE 11-8: TIME-OUT SEQUENCE ON POWER-UP ( $\overline{\text{MCLR}}$  NOT TIED TO  $V_{DD}$ ): CASE 1**

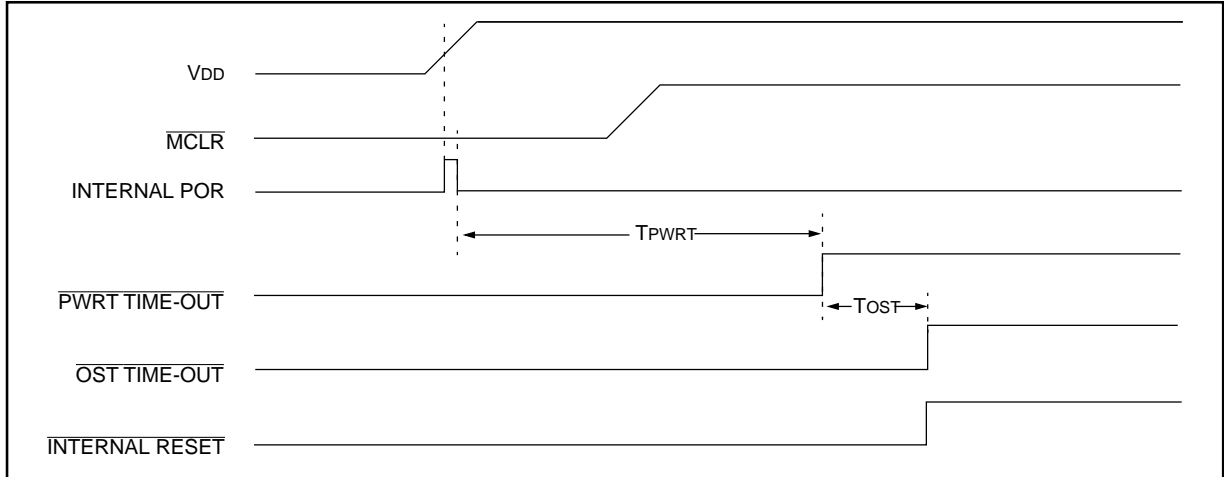

**FIGURE 11-9: TIME-OUT SEQUENCE ON POWER-UP ( $\overline{\text{MCLR}}$  NOT TIED TO  $V_{DD}$ ): CASE 2**

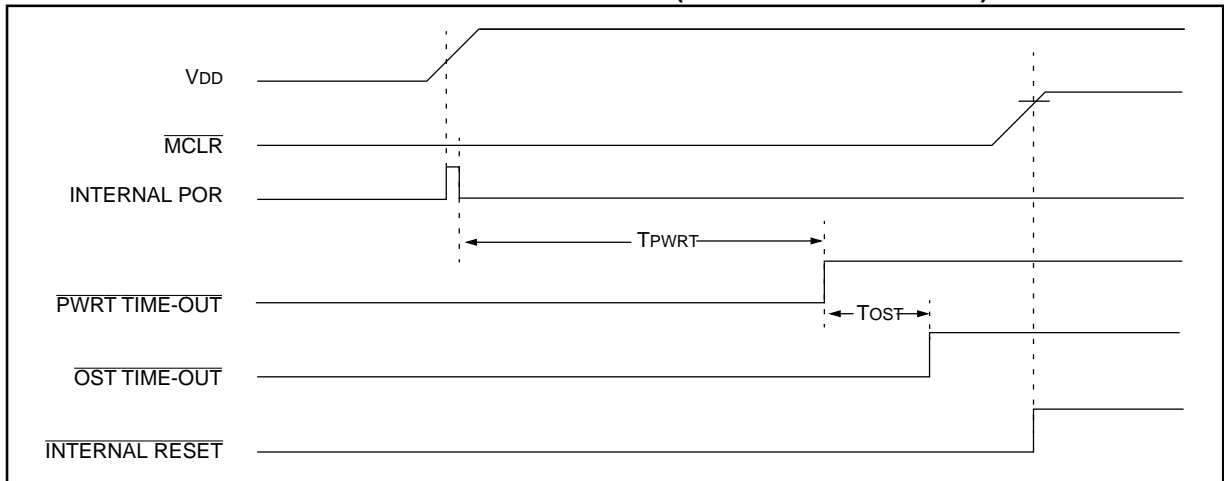

**FIGURE 11-10: SLOW RISE TIME ( $\overline{\text{MCLR}}$  TIED TO  $V_{DD}$ )**

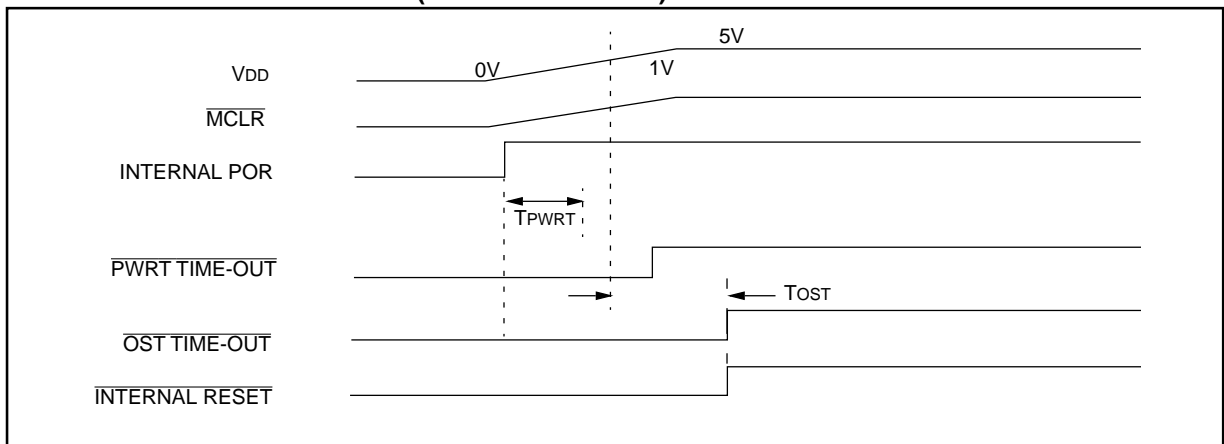

# PIC16C63A/65B/73B/74B

## 11.10 Interrupts

The PIC16CXX family has up to 12 sources of interrupt. The interrupt control register (INTCON) records individual interrupt requests in flag bits. It also has individual and global interrupt enable bits.

**Note:** Individual interrupt flag bits are set regardless of the status of their corresponding mask bit or the GIE bit.

A global interrupt enable bit, GIE (INTCON<7>) enables (if set) all un-masked interrupts or disables (if cleared) all interrupts. When bit GIE is enabled, and an interrupt's flag bit and mask bit are set, the interrupt will vector immediately. Individual interrupts can be disabled through their corresponding enable bits in various registers. Individual interrupt bits are set regardless of the status of the GIE bit. The GIE bit is cleared on reset.

The "return from interrupt" instruction, RETFIE, exits the interrupt routine as well as sets the GIE bit, which re-enables interrupts.

The RB0/INT pin interrupt, the RB port change interrupt and the TMR0 overflow interrupt flags are contained in the INTCON register.

The peripheral interrupt flags are contained in the special function registers PIR1 and PIR2. The corresponding interrupt enable bits are contained in special function registers PIE1 and PIE2, and the peripheral interrupt enable bit is contained in special function register INTCON.

When an interrupt is responded to, the GIE bit is cleared to disable any further interrupt, the return address is pushed onto the stack and the PC is loaded with 0004h. Once in the interrupt service routine, the source(s) of the interrupt can be determined by polling the interrupt flag bits. The interrupt flag bit(s) must be cleared in software before re-enabling interrupts to avoid recursive interrupts.

For external interrupt events, such as the INT pin or PORTB change interrupt, the interrupt latency will be three or four instruction cycles. The exact latency depends when the interrupt event occurs. The latency is the same for one or two cycle instructions. Individual interrupt flag bits are set regardless of the status of their corresponding mask bit or the GIE bit.

**FIGURE 11-11: INTERRUPT LOGIC**

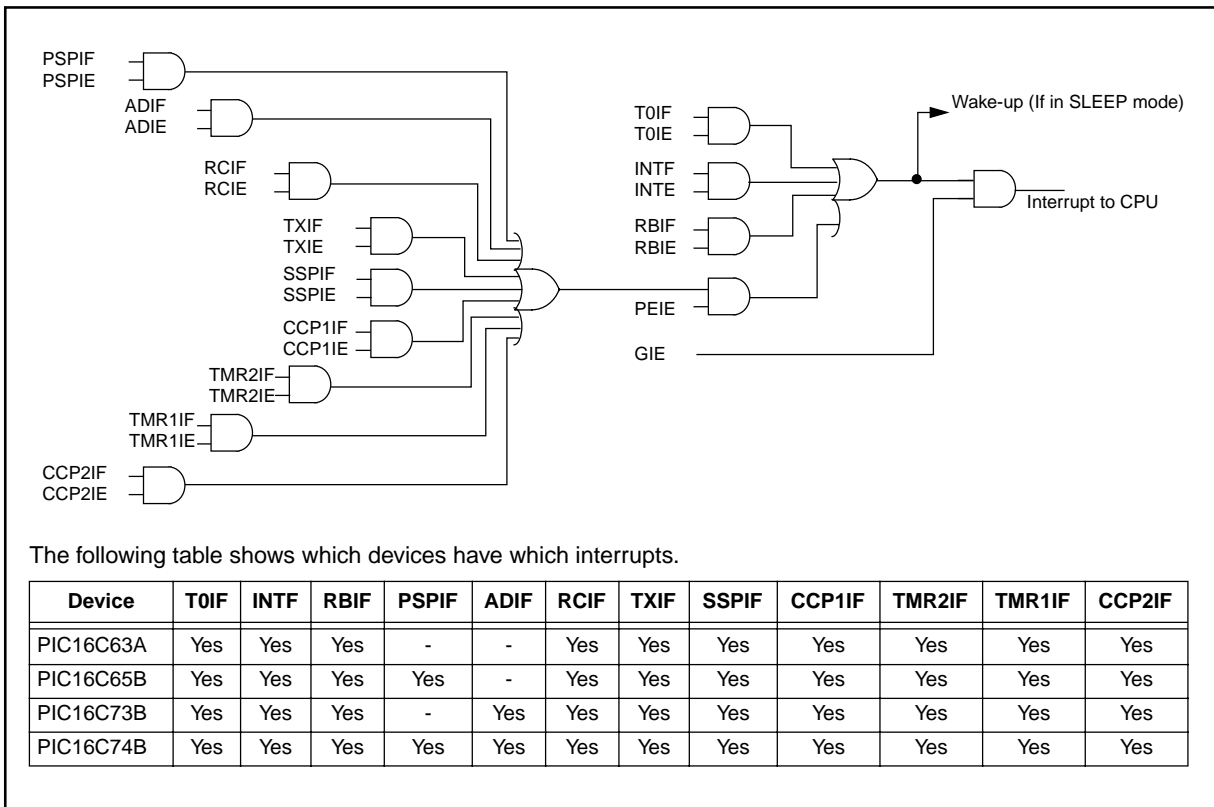

# PIC16C63A/65B/73B/74B

## 11.10.1 INT INTERRUPT

External interrupt on RB0/INT pin is edge triggered; either rising if bit INTEDG (OPTION\_REG<6>) is set, or falling, if the INTEDG bit is clear. When a valid edge appears on the RB0/INT pin, flag bit INTF (INTCON<1>) is set. This interrupt can be disabled by clearing enable bit INTE (INTCON<4>). Flag bit INTF must be cleared in software in the interrupt service routine before re-enabling this interrupt. The INT interrupt can wake-up the processor from SLEEP, if bit INTE was set prior to going into SLEEP. The status of global interrupt enable bit GIE decides whether or not the processor branches to the interrupt vector following wake-up. See Section 11.13 for details on SLEEP mode.

## 11.10.2 TMR0 INTERRUPT

An overflow (FFh → 00h) in the TMR0 register will set flag bit TOIF (INTCON<2>). The interrupt can be enabled/disabled by setting/clearing enable bit TOIE (INTCON<5>). (Section 4.0)

## 11.10.3 PORTB INTCON CHANGE

An input change on PORTB<7:4> sets flag bit RBIF (INTCON<0>). The interrupt can be enabled/disabled by setting/clearing enable bit RBIE (INTCON<4>). (Section 3.2)

## 11.11 Context Saving During Interrupts

During an interrupt, only the return PC value is saved on the stack. Typically, users may wish to save key registers during an interrupt, i.e., W register and STATUS register. This will have to be implemented in software.

Example 11-1 stores and restores the W and STATUS registers. The register, W\_TEMP, must be defined in each bank and must be defined at the same offset from the bank base address (i.e., if W\_TEMP is defined at 0x20 in bank 0. It must also be defined at 0xA0 in bank 1).

The example:

- a) Stores the W register.
- b) Stores the STATUS register in bank 0.
- c) Stores the PCLATH register.
- d) Executes the interrupt service routine code (User-generated).
- e) Restores the STATUS register (and bank select bit).
- f) Restores the W and PCLATH registers.

### EXAMPLE 11-1: SAVING STATUS, W, AND PCLATH REGISTERS IN RAM

```
MOVWF    W_TEMP           ;Copy W to TEMP register, could be bank one or zero
SWAPF    STATUS,W         ;Swap status to be saved into W
CLRF     STATUS           ;bank 0, regardless of current bank, Clears IRP,RP1,RP0
MOVWF    STATUS_TEMP      ;Save status to bank zero STATUS_TEMP register
MOVF     PCLATH, W        ;Only required if using pages 1, 2 and/or 3
MOVWF    PCLATH_TEMP      ;Save PCLATH into W
CLRF     PCLATH           ;Page zero, regardless of current page
BCF      STATUS, IRP      ;Return to Bank 0
MOVF     FSR, W           ;Copy FSR to W
MOVWF    FSR_TEMP        ;Copy FSR from W to FSR_TEMP
:
:(ISR)
:
MOVF     PCLATH_TEMP, W   ;Restore PCLATH
MOVWF    PCLATH           ;Move W into PCLATH
SWAPF    STATUS_TEMP,W    ;Swap STATUS_TEMP register into W
; (sets bank to original state)
MOVWF    STATUS           ;Move W into STATUS register
SWAPF    W_TEMP,F        ;Swap W_TEMP
SWAPF    W_TEMP,W        ;Swap W_TEMP into W
```

# PIC16C63A/65B/73B/74B

## 11.12 Watchdog Timer (WDT)

The Watchdog Timer is a free running on-chip RC oscillator, which does not require any external components. This RC oscillator is separate from the RC oscillator of the OSC1/CLKIN pin. That means that the WDT will run, even if the clock on the OSC1/CLKIN and OSC2/CLKOUT pins of the device has been stopped, for example, by execution of a SLEEP instruction.

During normal operation, a WDT time-out generates a device RESET (Watchdog Timer Reset). If the device is in SLEEP mode, a WDT time-out causes the device to wake-up and continue with normal operation (Watchdog Timer Wake-up). The  $\overline{TO}$  bit in the STATUS register will be cleared upon a Watchdog Timer time-out.

The WDT can be permanently disabled by clearing configuration bit WDTE (Section 11.1).

WDT time-out period values may be found in the Electrical Specifications section under parameter #31. Values for the WDT prescaler (actually a postscaler, but shared with the Timer0 prescaler) may be assigned using the OPTION\_REG register.

**Note:** The CLRWDT and SLEEP instructions clear the WDT and the postscaler if assigned to the WDT, and prevent it from timing out and generating a device RESET condition.

**Note:** When a CLRWDT instruction is executed and the prescaler is assigned to the WDT, the prescaler count will be cleared, but the prescaler assignment is not changed.

**FIGURE 11-12: WATCHDOG TIMER BLOCK DIAGRAM**

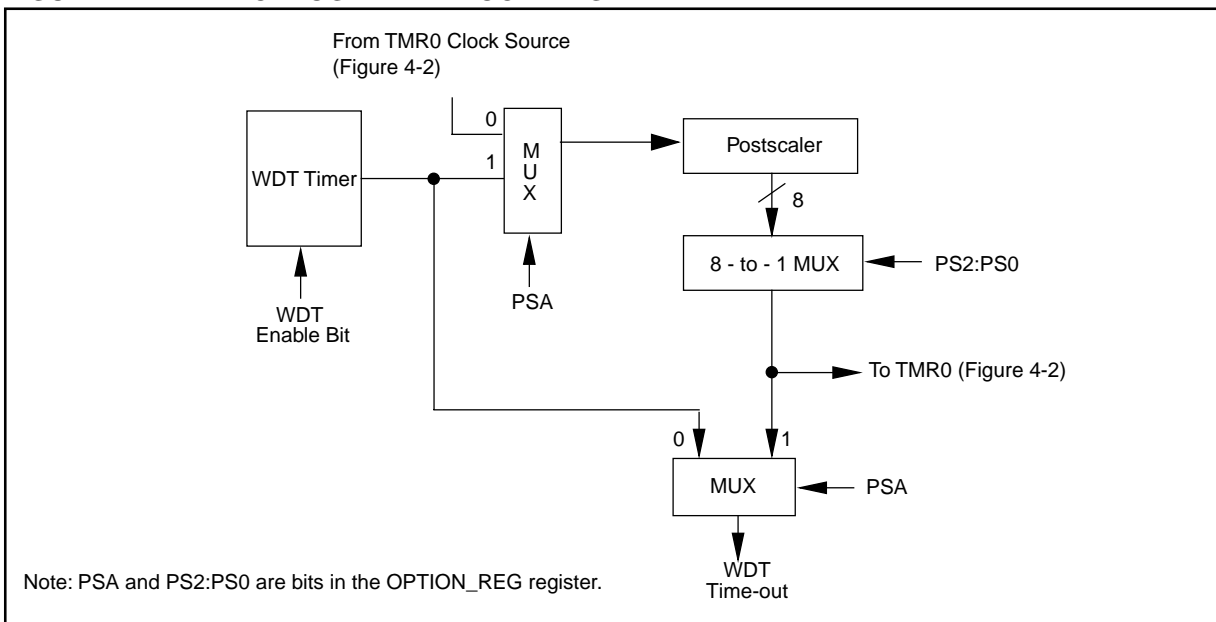

**FIGURE 11-13: SUMMARY OF WATCHDOG TIMER REGISTERS**

Address	Name	Bit 7	Bit 6	Bit 5	Bit 4	Bit 3	Bit 2	Bit 1	Bit 0
2007h	Config. bits	(1)	BODEN <sup>(1)</sup>	CP1	CP0	PWRTE <sup>(1)</sup>	WDTE	FOSC1	FOSC0
81h	OPTION_REG	$\overline{RBPU}$	INTEDG	T0CS	T0SE	PSA	PS2	PS1	PS0

Legend: Shaded cells are not used by the Watchdog Timer.

Note 1: See Figure 11-1 for operation of these bits.

## 11.13 Power-down Mode (SLEEP)

Power-down mode is entered by executing a `SLEEP` instruction.

If enabled, the Watchdog Timer will be cleared but keeps running, the `PD` bit (`STATUS<3>`) is cleared, the `TO` (`STATUS<4>`) bit is set, and the oscillator driver is turned off. The I/O ports maintain the status they had, before the `SLEEP` instruction was executed (driving high, low, or hi-impedance).

For lowest current consumption in this mode, place all I/O pins at either `VDD`, or `VSS`, ensure no external circuitry is drawing current from the I/O pin, power-down the A/D, disable external clocks. Pull all I/O pins, that are hi-impedance inputs, high or low externally to avoid switching currents caused by floating inputs. The `T0CKI` input should also be at `VDD` or `VSS` for lowest current consumption. The contribution from on-chip pull-ups on `PORTB` should be considered.

The `MCLR` pin must be at a logic high level (`VIHMC`).

### 11.13.1 WAKE-UP FROM SLEEP

The device can wake up from `SLEEP` through one of the following events:

1. External reset input on `MCLR` pin.
2. Watchdog Timer Wake-up (if `WDT` was enabled).
3. Interrupt from `INT` pin, `RB` port change, or some Peripheral Interrupts.

External `MCLR` Reset will cause a device reset. All other events are considered a continuation of program execution and cause a "wake-up". The `TO` and `PD` bits in the `STATUS` register can be used to determine the cause of device reset. The `PD` bit, which is set on power-up, is cleared when `SLEEP` is invoked. The `TO` bit is cleared if a `WDT` time-out occurred (and caused wake-up).

The following peripheral interrupts can wake the device from `SLEEP`:

1. `PSP` read or write.
2. `TMR1` interrupt. `Timer1` must be operating as an asynchronous counter.
3. `CCP` capture mode interrupt.
4. Special event trigger (`Timer1` in asynchronous mode using an external clock).
5. `SSP` (Start/Stop) bit detect interrupt.
6. `SSP` transmit or receive in slave mode (`SPI/I2C`).
7. `USART` `RX` or `TX` (synchronous slave mode).
8. A/D conversion (when A/D clock source is `RC`).

Other peripherals cannot generate interrupts since during `SLEEP`, no on-chip clocks are present.

When the `SLEEP` instruction is being executed, the next instruction (`PC + 1`) is pre-fetched. For the device to wake-up through an interrupt event, the corresponding interrupt enable bit must be set (enabled). Wake-up is regardless of the state of the `GIE` bit. If the `GIE` bit is clear (disabled), the device continues execution at the instruction after the `SLEEP` instruction. If the `GIE` bit is set (enabled), the device executes the instruction after the `SLEEP` instruction and then branches to the interrupt address (`0004h`). In cases where the execution of the instruction following `SLEEP` is not desirable, the user should have a `NOP` after the `SLEEP` instruction.

### 11.13.2 WAKE-UP USING INTERRUPTS

When global interrupts are disabled (`GIE` cleared) and any interrupt source has both its interrupt enable bit and interrupt flag bit set, one of the following will occur:

- If the interrupt occurs **before** the execution of a `SLEEP` instruction, the `SLEEP` instruction will complete as a `NOP`. Therefore, the `WDT` and `WDT` postscaler will not be cleared, the `TO` bit will not be set and `PD` bits will not be cleared.
- If the interrupt occurs **during or after** the execution of a `SLEEP` instruction, the device will immediately wake up from sleep. The `SLEEP` instruction will be completely executed before the wake-up. Therefore, the `WDT` and `WDT` postscaler will be cleared, the `TO` bit will be set and the `PD` bit will be cleared.

Even if the flag bits were checked before executing a `SLEEP` instruction, it may be possible for flag bits to become set before the `SLEEP` instruction completes. To determine whether a `SLEEP` instruction executed, test the `PD` bit. If the `PD` bit is set, the `SLEEP` instruction was executed as a `NOP`.

To ensure that the `WDT` is cleared, a `CLRWDT` instruction should be executed before a `SLEEP` instruction.

# PIC16C63A/65B/73B/74B

**FIGURE 11-14: WAKE-UP FROM SLEEP THROUGH INTERRUPT**

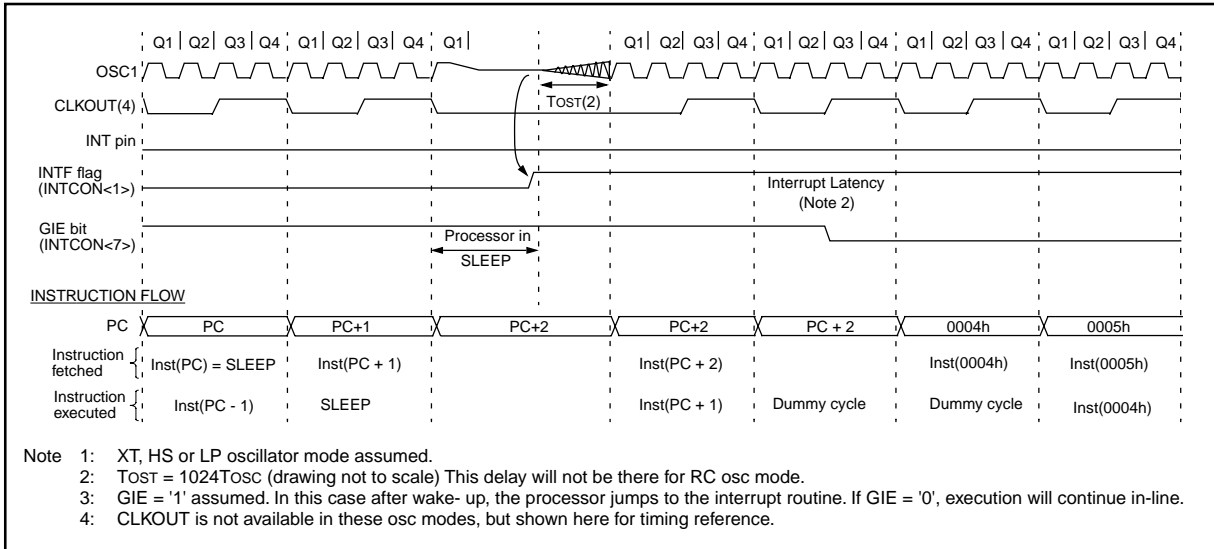

## 11.14 Program Verification/Code Protection

If the code protection bit(s) have not been programmed, the on-chip program memory can be read out for verification purposes.

**Note:** Microchip Technology does not recommend code protecting windowed devices.

## 11.15 ID Locations

Four memory locations (2000h - 2003h) are designated as ID locations where the user can store checksum or other code-identification numbers. These locations are not accessible during normal execution but are readable and writable during program/verify. It is recommended that only the 4 least significant bits of the ID location are used.

For ROM devices, these values are submitted along with the ROM code.

## 11.16 In-Circuit Serial Programming

PIC16CXXX microcontrollers can be serially programmed while in the end application circuit. This is simply done with two lines for clock and data, and three other lines for power, ground and the programming voltage. This allows customers to manufacture boards with unprogrammed devices, and then program the microcontroller just before shipping the product. This also allows the most recent firmware or a custom firmware to be programmed.

For complete details of serial programming, please refer to the In-Circuit Serial Programming (ICSP™) Guide, (DS30277B).

# PIC16C63A/65B/73B/74B

## 12.0 INSTRUCTION SET SUMMARY

Each PIC16CXXX instruction is a 14-bit word divided into an OPCODE which specifies the instruction type and one or more operands which further specify the operation of the instruction. The PIC16CXX instruction set summary in Table 12-2 lists **byte-oriented**, **bit-oriented**, and **literal and control** operations. Table 12-1 shows the opcode field descriptions.

For **byte-oriented** instructions, 'f' represents a file register designator and 'd' represents a destination designator. The file register designator specifies which file register is to be used by the instruction.

The destination designator specifies where the result of the operation is to be placed. If 'd' is zero, the result is placed in the W register. If 'd' is one, the result is placed in the file register specified in the instruction.

For **bit-oriented** instructions, 'b' represents a bit field designator which selects the number of the bit affected by the operation, while 'f' represents the number of the file in which the bit is located.

For **literal and control** operations, 'k' represents an eight or eleven bit constant or literal value.

**TABLE 12-1: OPCODE FIELD DESCRIPTIONS**

Field	Description
f	Register file address (0x00 to 0x7F)
w	Working register (accumulator)
b	Bit address within an 8-bit file register
k	Literal field, constant data or label
x	Don't care location (= 0 or 1) The assembler will generate code with x = 0. It is the recommended form of use for compatibility with all Microchip Technology software tools.
d	Destination select; d = 0: store result in W, d = 1: store result in file register f. Default is d = 1
PC	Program Counter
TO	Time-out bit
PD	Power-down bit

The instruction set is highly orthogonal and is grouped into three basic categories:

- **Byte-oriented** operations
- **Bit-oriented** operations
- **Literal and control** operations

All instructions are executed within one single instruction cycle, unless a conditional test is true or the program counter is changed as a result of an instruction. In this case, the execution takes two instruction cycles with the second cycle executed as a NOP. One instruction cycle consists of four oscillator periods. Thus, for an oscillator frequency of 4 MHz, the normal instruction execution time is 1 μs. If a conditional test is true or the program counter is changed as a result of an instruction, the instruction execution time is 2 μs.

Table 12-2 lists the instructions recognized by the MPASM assembler.

Figure 12-1 shows the general formats that the instructions can have.

**Note:** To maintain upward compatibility with future PIC16CXXX products, do not use the OPTION and TRIS instructions.

All examples use the following format to represent a hexadecimal number:

0xhh

where h signifies a hexadecimal digit.

**FIGURE 12-1: GENERAL FORMAT FOR INSTRUCTIONS**

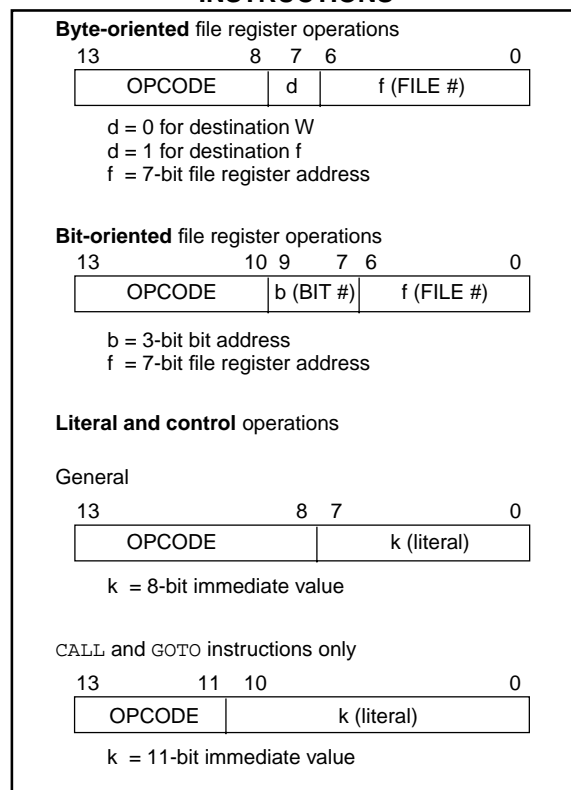

A description of each instruction is available in the PICmicro™ Mid-Range Reference Manual, (DS33023).

# PIC16C63A/65B/73B/74B

TABLE 12-2: PIC16CXXX INSTRUCTION SET

Mnemonic, Operands	Description	Cycles	14-Bit Opcode				Status Affected	Notes
			MSb			LSb		
<b>BYTE-ORIENTED FILE REGISTER OPERATIONS</b>								
<b>ADDWF</b>	<b>f, d</b> Add W and f	1	00	0111	dfff	ffff	C,DC,Z	1,2
<b>ANDWF</b>	<b>f, d</b> AND W with f	1	00	0101	dfff	ffff	Z	1,2
<b>CLRF</b>	<b>f</b> Clear f	1	00	0001	1fff	ffff	Z	2
<b>CLRWF</b>	<b>-</b> Clear W	1	00	0001	0xxx	xxxx	Z	
<b>COMF</b>	<b>f, d</b> Complement f	1	00	1001	dfff	ffff	Z	1,2
<b>DECF</b>	<b>f, d</b> Decrement f	1	00	0011	dfff	ffff	Z	1,2
<b>DECFSZ</b>	<b>f, d</b> Decrement f, Skip if 0	1(2)	00	1011	dfff	ffff		1,2,3
<b>INCF</b>	<b>f, d</b> Increment f	1	00	1010	dfff	ffff	Z	1,2
<b>INCFSZ</b>	<b>f, d</b> Increment f, Skip if 0	1(2)	00	1111	dfff	ffff		1,2,3
<b>IORWF</b>	<b>f, d</b> Inclusive OR W with f	1	00	0100	dfff	ffff	Z	1,2
<b>MOVF</b>	<b>f, d</b> Move f	1	00	1000	dfff	ffff	Z	1,2
<b>MOVWF</b>	<b>f</b> Move W to f	1	00	0000	1fff	ffff		
<b>NOP</b>	<b>-</b> No Operation	1	00	0000	0xx0	0000		
<b>RLF</b>	<b>f, d</b> Rotate Left f through Carry	1	00	1101	dfff	ffff	C	1,2
<b>RRF</b>	<b>f, d</b> Rotate Right f through Carry	1	00	1100	dfff	ffff	C	1,2
<b>SUBWF</b>	<b>f, d</b> Subtract W from f	1	00	0010	dfff	ffff	C,DC,Z	1,2
<b>SWAPF</b>	<b>f, d</b> Swap nibbles in f	1	00	1110	dfff	ffff		1,2
<b>XORWF</b>	<b>f, d</b> Exclusive OR W with f	1	00	0110	dfff	ffff	Z	1,2
<b>BIT-ORIENTED FILE REGISTER OPERATIONS</b>								
<b>BCF</b>	<b>f, b</b> Bit Clear f	1	01	00bb	bfff	ffff		1,2
<b>BSF</b>	<b>f, b</b> Bit Set f	1	01	01bb	bfff	ffff		1,2
<b>BTFSC</b>	<b>f, b</b> Bit Test f, Skip if Clear	1 (2)	01	10bb	bfff	ffff		3
<b>BTFSS</b>	<b>f, b</b> Bit Test f, Skip if Set	1 (2)	01	11bb	bfff	ffff		3
<b>LITERAL AND CONTROL OPERATIONS</b>								
<b>ADDLW</b>	<b>k</b> Add literal and W	1	11	111x	kkkk	kkkk	C,DC,Z	
<b>ANDLW</b>	<b>k</b> AND literal with W	1	11	1001	kkkk	kkkk	Z	
<b>CALL</b>	<b>k</b> Call subroutine	2	10	0kkk	kkkk	kkkk		
<b>CLRWDT</b>	<b>-</b> Clear Watchdog Timer	1	00	0000	0110	0100	$\overline{TO}, \overline{PD}$	
<b>GOTO</b>	<b>k</b> Go to address	2	10	1kkk	kkkk	kkkk		
<b>IORLW</b>	<b>k</b> Inclusive OR literal with W	1	11	1000	kkkk	kkkk	Z	
<b>MOVLW</b>	<b>k</b> Move literal to W	1	11	00xx	kkkk	kkkk		
<b>RETFIE</b>	<b>-</b> Return from interrupt	2	00	0000	0000	1001		
<b>RETLW</b>	<b>k</b> Return with literal in W	2	11	01xx	kkkk	kkkk		
<b>RETURN</b>	<b>-</b> Return from Subroutine	2	00	0000	0000	1000		
<b>SLEEP</b>	<b>-</b> Go into standby mode	1	00	0000	0110	0011	$\overline{TO}, \overline{PD}$	
<b>SUBLW</b>	<b>k</b> Subtract W from literal	1	11	110x	kkkk	kkkk	C,DC,Z	
<b>XORLW</b>	<b>k</b> Exclusive OR literal with W	1	11	1010	kkkk	kkkk	Z	

**Note 1:** When an I/O register is modified as a function of itself ( e.g., `MOVF PORTB, 1`), the value used will be that value present on the pins themselves. For example, if the data latch is '1' for a pin configured as input and is driven low by an external device, the data will be written back with a '0'.

**2:** If this instruction is executed on the TMR0 register (and, where applicable, d = 1), the prescaler will be cleared if assigned to the Timer0 Module.

**3:** If Program Counter (PC) is modified or a conditional test is true, the instruction requires two cycles. The second cycle is executed as a NOP.



## 13.0 DEVELOPMENT SUPPORT

### 13.1 Development Tools

The PICmicro™ microcontrollers are supported with a full range of hardware and software development tools:

- PICMASTER®/PICMASTER CE Real-Time In-Circuit Emulator
- ICEPIC™ Low-Cost PIC16C5X and PIC16CXXX In-Circuit Emulator
- PRO MATE® II Universal Programmer
- PICSTART® Plus Entry-Level Prototype Programmer
- PICDEM-1 Low-Cost Demonstration Board
- PICDEM-2 Low-Cost Demonstration Board
- PICDEM-3 Low-Cost Demonstration Board
- MPASM Assembler
- MPLAB™ SIM Software Simulator
- MPLAB-C17 (C Compiler)
- Fuzzy Logic Development System (*fuzzyTECH*®-MP)

### 13.2 PICMASTER: High Performance Universal In-Circuit Emulator with MPLAB IDE

The PICMASTER Universal In-Circuit Emulator is intended to provide the product development engineer with a complete microcontroller design tool set for all microcontrollers in the PIC14C000, PIC12CXXX, PIC16C5X, PIC16CXXX and PIC17CXX families. PICMASTER is supplied with the MPLAB™ Integrated Development Environment (IDE), which allows editing, "make" and download, and source debugging from a single environment.

Interchangeable target probes allow the system to be easily reconfigured for emulation of different processors. The universal architecture of the PICMASTER allows expansion to support all new Microchip microcontrollers.

The PICMASTER Emulator System has been designed as a real-time emulation system with advanced features that are generally found on more expensive development tools. The PC compatible 386 (and higher) machine platform and Microsoft Windows® 3.x environment were chosen to best make these features available to you, the end user.

A CE compliant version of PICMASTER is available for European Union (EU) countries.

### 13.3 ICEPIC: Low-Cost PICmicro™ In-Circuit Emulator

ICEPIC is a low-cost in-circuit emulator solution for the Microchip PIC12CXXX, PIC16C5X and PIC16CXXX families of 8-bit OTP microcontrollers.

ICEPIC is designed to operate on PC-compatible machines ranging from 286-AT® through Pentium™ based machines under Windows 3.x environment. ICEPIC features real time, non-intrusive emulation.

### 13.4 PRO MATE II: Universal Programmer

The PRO MATE II Universal Programmer is a full-featured programmer capable of operating in stand-alone mode as well as PC-hosted mode. PRO MATE II is CE compliant.

The PRO MATE II has programmable VDD and VPP supplies which allows it to verify programmed memory at VDD min and VDD max for maximum reliability. It has an LCD display for displaying error messages, keys to enter commands and a modular detachable socket assembly to support various package types. In stand-alone mode the PRO MATE II can read, verify or program PIC12CXXX, PIC14C000, PIC16C5X, PIC16CXXX and PIC17CXX devices. It can also set configuration and code-protect bits in this mode.

### 13.5 PICSTART Plus Entry Level Development System

The PICSTART programmer is an easy-to-use, low-cost prototype programmer. It connects to the PC via one of the COM (RS-232) ports. MPLAB Integrated Development Environment software makes using the programmer simple and efficient. PICSTART Plus is not recommended for production programming.

PICSTART Plus supports all PIC12CXXX, PIC14C000, PIC16C5X, PIC16CXXX and PIC17CXX devices with up to 40 pins. Larger pin count devices such as the PIC16C923, PIC16C924 and PIC17C756 may be supported with an adapter socket. PICSTART Plus is CE compliant.

# PIC16C62X(A)

---

## 13.6 PICDEM-1 Low-Cost PICmicro Demonstration Board

The PICDEM-1 is a simple board which demonstrates the capabilities of several of Microchip's microcontrollers. The microcontrollers supported are: PIC16C5X (PIC16C54 to PIC16C58A), PIC16C61, PIC16C62X, PIC16C71, PIC16C8X, PIC17C42, PIC17C43 and PIC17C44. All necessary hardware and software is included to run basic demo programs. The users can program the sample microcontrollers provided with the PICDEM-1 board, on a PRO MATE II or PICSTART-Plus programmer, and easily test firmware. The user can also connect the PICDEM-1 board to the PICMASTER emulator and download the firmware to the emulator for testing. Additional prototype area is available for the user to build some additional hardware and connect it to the microcontroller socket(s). Some of the features include an RS-232 interface, a potentiometer for simulated analog input, push-button switches and eight LEDs connected to PORTB.

## 13.7 PICDEM-2 Low-Cost PIC16CXXX Demonstration Board

The PICDEM-2 is a simple demonstration board that supports the PIC16C62, PIC16C64, PIC16C65, PIC16C73 and PIC16C74 microcontrollers. All the necessary hardware and software is included to run the basic demonstration programs. The user can program the sample microcontrollers provided with the PICDEM-2 board, on a PRO MATE II programmer or PICSTART-Plus, and easily test firmware. The PICMASTER emulator may also be used with the PICDEM-2 board to test firmware. Additional prototype area has been provided to the user for adding additional hardware and connecting it to the microcontroller socket(s). Some of the features include a RS-232 interface, push-button switches, a potentiometer for simulated analog input, a Serial EEPROM to demonstrate usage of the I<sup>2</sup>C bus and separate headers for connection to an LCD module and a keypad.

## 13.8 PICDEM-3 Low-Cost PIC16CXXX Demonstration Board

The PICDEM-3 is a simple demonstration board that supports the PIC16C923 and PIC16C924 in the PLCC package. It will also support future 44-pin PLCC microcontrollers with a LCD Module. All the necessary hardware and software is included to run the basic demonstration programs. The user can program the sample microcontrollers provided with the PICDEM-3 board, on a PRO MATE II programmer or PICSTART Plus with an adapter socket, and easily test firmware. The PICMASTER emulator may also be used with the PICDEM-3 board to test firmware. Additional prototype area has been provided to the user for adding hardware and connecting it to the microcontroller socket(s). Some of the features include

an RS-232 interface, push-button switches, a potentiometer for simulated analog input, a thermistor and separate headers for connection to an external LCD module and a keypad. Also provided on the PICDEM-3 board is an LCD panel, with 4 commons and 12 segments, that is capable of displaying time, temperature and day of the week. The PICDEM-3 provides an additional RS-232 interface and Windows 3.1 software for showing the demultiplexed LCD signals on a PC. A simple serial interface allows the user to construct a hardware demultiplexer for the LCD signals.

## 13.9 MPLAB™ Integrated Development Environment Software

The MPLAB IDE Software brings an ease of software development previously unseen in the 8-bit microcontroller market. MPLAB is a windows based application which contains:

- A full featured editor
- Three operating modes
  - editor
  - emulator
  - simulator
- A project manager
- Customizable tool bar and key mapping
- A status bar with project information
- Extensive on-line help

MPLAB allows you to:

- Edit your source files (either assembly or 'C')
- One touch assemble (or compile) and download to PICmicro tools (automatically updates all project information)
- Debug using:
  - source files
  - absolute listing file
- Transfer data dynamically via DDE (soon to be replaced by OLE)
- Run up to four emulators on the same PC

The ability to use MPLAB with Microchip's simulator allows a consistent platform and the ability to easily switch from the low cost simulator to the full featured emulator with minimal retraining due to development tools.

## 13.10 Assembler (MPASM)

The MPASM Universal Macro Assembler is a PC-hosted symbolic assembler. It supports all microcontroller series including the PIC12C5XX, PIC14000, PIC16C5X, PIC16CXXX, and PIC17CXX families.

MPASM offers full featured Macro capabilities, conditional assembly, and several source and listing formats. It generates various object code formats to support Microchip's development tools as well as third party programmers.

MPASM allows full symbolic debugging from PICMASTER, Microchip's Universal Emulator System.

MPASM has the following features to assist in developing software for specific use applications.

- Provides translation of Assembler source code to object code for all Microchip microcontrollers.
- Macro assembly capability.
- Produces all the files (Object, Listing, Symbol, and special) required for symbolic debug with Microchip's emulator systems.
- Supports Hex (default), Decimal and Octal source and listing formats.

MPASM provides a rich directive language to support programming of the PICmicro. Directives are helpful in making the development of your assemble source code shorter and more maintainable.

### **13.11 Software Simulator (MPLAB-SIM)**

The MPLAB-SIM Software Simulator allows code development in a PC host environment. It allows the user to simulate the PICmicro series microcontrollers on an instruction level. On any given instruction, the user may examine or modify any of the data areas or provide external stimulus to any of the pins. The input/output radix can be set by the user and the execution can be performed in; single step, execute until break, or in a trace mode.

MPLAB-SIM fully supports symbolic debugging using MPLAB-C and MPASM. The Software Simulator offers the low cost flexibility to develop and debug code outside of the laboratory environment making it an excellent multi-project software development tool.

### **13.12 C Compiler (MPLAB-C17)**

The MPLAB-C Code Development System is a complete 'C' compiler and integrated development environment for Microchip's PIC17CXXX family of microcontrollers. The compiler provides powerful integration capabilities and ease of use not found with other compilers.

For easier source level debugging, the compiler provides symbol information that is compatible with the MPLAB IDE memory display.

### **13.13 Fuzzy Logic Development System (fuzzyTECH-MP)**

*fuzzyTECH-MP* fuzzy logic development tool is available in two versions - a low cost introductory version, MP Explorer, for designers to gain a comprehensive working knowledge of fuzzy logic system design; and a full-featured version, *fuzzyTECH-MP*, Edition for implementing more complex systems.

Both versions include Microchip's *fuzzyLAB*<sup>™</sup> demonstration board for hands-on experience with fuzzy logic systems implementation.

### **13.14 MP-DriveWay<sup>™</sup> – Application Code Generator**

MP-DriveWay is an easy-to-use Windows-based Application Code Generator. With MP-DriveWay you can visually configure all the peripherals in a PICmicro device and, with a click of the mouse, generate all the initialization and many functional code modules in C language. The output is fully compatible with Microchip's MPLAB-C C compiler. The code produced is highly modular and allows easy integration of your own code. MP-DriveWay is intelligent enough to maintain your code through subsequent code generation.

### **13.15 SEEVAL<sup>®</sup> Evaluation and Programming System**

The SEEVAL SEEPROM Designer's Kit supports all Microchip 2-wire and 3-wire Serial EEPROMs. The kit includes everything necessary to read, write, erase or program special features of any Microchip SEEPROM product including Smart Serial<sup>™</sup> and secure serials. The Total Endurance<sup>™</sup> Disk is included to aid in trade-off analysis and reliability calculations. The total kit can significantly reduce time-to-market and result in an optimized system.

### **13.16 KEELOQ<sup>®</sup> Evaluation and Programming Tools**

KEELOQ evaluation and programming tools support Microchips HCS Secure Data Products. The HCS evaluation kit includes an LCD display to show changing codes, a decoder to decode transmissions, and a programming interface to program test transmitters.

# PIC16C62X(A)

TABLE 13-1 DEVELOPMENT TOOLS FROM MICROCHIP

	PIC12C5XX	PIC14000	PIC16C5X	PIC16CXXX	PIC16C6X	PIC16C7XX	PIC16C8X	PIC16C9XX	PIC17C4X	PIC17C7XX	24CXX 25CXX 93CXX	HCSXXX
<b>EMULATOR PRODUCTS</b>												
PICMASTER <sup>®</sup> / PICMASTER-CE In-Circuit Emulator	✓	✓	✓	✓	✓	✓	✓	✓	✓	(PIC17C75X only) ✓		
MPLAB <sup>™</sup> -ICE										✓		
ICEPIC <sup>™</sup> Low-Cost In-Circuit Emulator	✓		✓	✓	✓	✓	✓	✓				
<b>SOFTWARE PRODUCTS</b>												
MPLAB <sup>™</sup> Integrated Development Environment	✓	✓	✓	✓	✓	✓	✓	✓	✓	✓		
MPLAB <sup>™</sup> C17 Compiler									✓	✓		
fuzzyTECH <sup>®</sup> -MP Explorer/Edition Fuzzy Logic Dev. Tool	✓	✓	✓	✓	✓	✓	✓	✓	✓			
MP-DriveWay <sup>™</sup> Applications Code Generator			✓	✓	✓	✓	✓	✓	✓		✓	
Total Endurance <sup>™</sup> Software Model											✓	
<b>PROGRAMMERS</b>												
PICSTART <sup>®</sup> Plus Low-Cost Universal Dev. Kit	✓	✓	✓	✓	✓	✓	✓	✓	✓	✓		
PRO MATE <sup>®</sup> II Universal Programmer	✓	✓	✓	✓	✓	✓	✓	✓	✓	✓	✓	✓
KEELOQ <sup>®</sup> Programmer											✓	✓
<b>DEMO BOARDS</b>												
SEEVAL <sup>®</sup> Designers Kit											✓	
PICDEM-1			✓				✓		✓			
PICDEM-2					✓							
PICDEM-3								✓				

# PIC16C63A/65B/73B/74B

## 14.0 ELECTRICAL CHARACTERISTICS

### Absolute Maximum Ratings <sup>(†)</sup>

Ambient temperature under bias.....	-55°C to +125°C
Storage temperature.....	-65°C to +150°C
Voltage on any pin with respect to V <sub>SS</sub> (except V <sub>DD</sub> , $\overline{\text{MCLR}}$ , and RA4).....	-0.3V to (V <sub>DD</sub> + 0.3V)
Voltage on V <sub>DD</sub> with respect to V <sub>SS</sub> .....	-0.3V to +7.5V
Voltage on $\overline{\text{MCLR}}$ with respect to V <sub>SS</sub> (Note 2).....	0V to +13.25V
Voltage on RA4 with respect to V <sub>SS</sub> .....	0V to +8.5V
Total power dissipation (Note 1).....	1.0W
Maximum current out of V <sub>SS</sub> pin.....	300 mA
Maximum current into V <sub>DD</sub> pin.....	250 mA
Input clamp current, I <sub>IK</sub> (V <sub>I</sub> < 0 or V <sub>I</sub> > V <sub>DD</sub> ).....	±20 mA
Output clamp current, I <sub>OK</sub> (V <sub>O</sub> < 0 or V <sub>O</sub> > V <sub>DD</sub> ).....	±20 mA
Maximum output current sunk by any I/O pin.....	25 mA
Maximum output current sourced by any I/O pin.....	25 mA
Maximum current sunk by PORTA, PORTB, and PORTE (Note 3) (combined).....	200 mA
Maximum current sourced by PORTA, PORTB, and PORTE (Note 3) (combined).....	200 mA
Maximum current sunk by PORTC and PORTD (Note 3) (combined).....	200 mA
Maximum current sourced by PORTC and PORTD (Note 3) (combined).....	200 mA

**Note 1:** Power dissipation is calculated as follows:  $P_{dis} = V_{DD} \times \{I_{DD} - \sum I_{OH}\} + \sum \{(V_{DD} - V_{OH}) \times I_{OH}\} + \sum (V_{OL} \times I_{OL})$

**Note 2:** Voltage spikes below V<sub>SS</sub> at the  $\overline{\text{MCLR}}$ /V<sub>PP</sub> pin, inducing currents greater than 80 mA, may cause latch-up. Thus, a series resistor of 50-100Ω should be used when applying a “low” level to the  $\overline{\text{MCLR}}$ /V<sub>PP</sub> pin rather than pulling this pin directly to V<sub>SS</sub>.

**Note 3:** PORTD and PORTE not available on the PIC16C63A/73B.

† NOTICE: Stresses above those listed under “Absolute Maximum Ratings” may cause permanent damage to the device. This is a stress rating only and functional operation of the device at those or any other conditions above those indicated in the operation listings of this specification is not implied. Exposure to maximum rating conditions for extended periods may affect device reliability.

**TABLE 14-1: CROSS REFERENCE OF DEVICE SPECS FOR OSCILLATOR MODES AND FREQUENCIES OF OPERATION (COMMERCIAL DEVICES)**

OSC	PIC16C63A-04 PIC16C65B-04 PIC16C73B-04 PIC16C74B-04	PIC16C63A-20 PIC16C65B-20 PIC16C73B-20 PIC16C74B-20	PIC16LC63A-04 PIC16LC65B-04 PIC16LC73B-04 PIC16LC74B-04	Windowed (JW) Devices
RC	V <sub>DD</sub> : 4.0V to 5.5V I <sub>DD</sub> : 5 mA max. at 5.5V I <sub>PD</sub> : 16 μA max. at 4V Freq: 4 MHz max.	V <sub>DD</sub> : 4.5V to 5.5V I <sub>DD</sub> : 2.7 mA typ. at 5.5V I <sub>PD</sub> : 1.5 μA typ. at 4V Freq: 4 MHz max.	V <sub>DD</sub> : 2.5V to 5.5V I <sub>DD</sub> : 3.8 mA max. at 3V I <sub>PD</sub> : 5 μA max. at 3V Freq: 4 MHz max.	V <sub>DD</sub> : 2.5V to 5.5V I <sub>DD</sub> : 3.8 mA max. at 3V I <sub>PD</sub> : 5 μA max. at 3V Freq: 4 MHz max.
XT	V <sub>DD</sub> : 4.0V to 5.5V I <sub>DD</sub> : 5 mA max. at 5.5V I <sub>PD</sub> : 16 μA max. at 4V Freq: 4 MHz max.	V <sub>DD</sub> : 4.5V to 5.5V I <sub>DD</sub> : 2.7 mA typ. at 5.5V I <sub>PD</sub> : 1.5 μA typ. at 4V Freq: 4 MHz max.	V <sub>DD</sub> : 2.5V to 5.5V I <sub>DD</sub> : 3.8 mA max. at 3V I <sub>PD</sub> : 5 μA max. at 3V Freq: 4 MHz max.	V <sub>DD</sub> : 2.5V to 5.5V I <sub>DD</sub> : 3.8 mA max. at 3V I <sub>PD</sub> : 5 μA max. at 3V Freq: 4 MHz max.
HS	V <sub>DD</sub> : 4.5V to 5.5V I <sub>DD</sub> : 13.5 mA typ. at 5.5V I <sub>PD</sub> : 1.5 μA typ. at 4.5V Freq: 4 MHz max.	V <sub>DD</sub> : 4.5V to 5.5V I <sub>DD</sub> : 20 mA max. at 5.5V I <sub>PD</sub> : 1.5 μA typ. at 4.5V Freq: 20 MHz max.	Not recommended for use in HS mode	V <sub>DD</sub> : 4.5V to 5.5V I <sub>DD</sub> : 20 mA max. at 5.5V I <sub>PD</sub> : 1.5 μA typ. at 4.5V Freq: 20 MHz max.
LP	V <sub>DD</sub> : 4.0V to 5.5V I <sub>DD</sub> : 52.5 μA typ. at 32 kHz, 4.0V I <sub>PD</sub> : 0.9 μA typ. at 4.0V Freq: 200 kHz max.	Not recommended for use in LP mode	V <sub>DD</sub> : 2.5V to 5.5V I <sub>DD</sub> : 48 μA max. at 32 kHz, 3.0V I <sub>PD</sub> : 5 μA max. at 3.0V Freq: 200 kHz max.	V <sub>DD</sub> : 2.5V to 5.5V I <sub>DD</sub> : 48 μA max. at 32 kHz, 3.0V I <sub>PD</sub> : 5 μA max. at 3.0V Freq: 200 kHz max.

The shaded sections indicate oscillator selections which are tested for functionality, but not for MIN/MAX specifications. It is recommended that the user select the device type that ensures the specifications required.

# PIC16C63A/65B/73B/74B

## 14.1 DC Characteristics: PIC16C63A/65B/73B/74B-04 (Commercial, Industrial, Extended) PIC16C6A/65B/73B/74B-20 (Commercial, Industrial, Extended)

Standard Operating Conditions (unless otherwise stated)							
DC CHARACTERISTICS							
Operating temperature $0^{\circ}\text{C} \leq T_A \leq +70^{\circ}\text{C}$ for commercial $-40^{\circ}\text{C} \leq T_A \leq +85^{\circ}\text{C}$ for industrial $-40^{\circ}\text{C} \leq T_A \leq +125^{\circ}\text{C}$ for extended							
Param No.	Sym	Characteristic	Min	Typ†	Max	Units	Conditions
D001 D001A	VDD	<b>Supply Voltage</b>	4.0 4.5 VBOR*	- - -	5.5 5.5 5.5	V V V	XT, RC and LP osc mode HS osc mode BOR enabled (Note 7)
D002*	VDR	<b>RAM Data Retention Voltage</b> (Note 1)	-	1.5	-	V	
D003	VPOR	<b>VDD Start Voltage</b> to ensure internal Power-on Reset signal	-	VSS	-	V	See section on Power-on Reset for details
D004* D004A*	SVDD	<b>VDD Rise Rate</b> to ensure internal Power-on Reset signal	0.05 TBD	- -	- -	V/ms	PWRT enabled ( $\overline{\text{PWRT}}\text{E}$ bit clear) PWRT disabled ( $\overline{\text{PWRT}}\text{E}$ bit set) See section on Power-on Reset for details
D005	VBOR	<b>Brown-out Reset voltage trip point</b>	3.65	-	4.35	V	BODEN bit set
D010 D013	IDD	<b>Supply Current</b> (Note 2, 5)	- -	2.7 10	5 20	mA mA	XT, RC osc modes FOSC = 4 MHz, VDD = 5.5V (Note 4) HS osc mode FOSC = 20 MHz, VDD = 5.5V
D020 D021 D021B	IPD	<b>Power-down Current</b> (Note 3, 5)	- - - -	10.5 1.5 1.5 2.5	42 16 19 19	$\mu\text{A}$ $\mu\text{A}$ $\mu\text{A}$ $\mu\text{A}$	VDD = 4.0V, WDT enabled, $-40^{\circ}\text{C}$ to $+85^{\circ}\text{C}$ VDD = 4.0V, WDT disabled, $0^{\circ}\text{C}$ to $+70^{\circ}\text{C}$ VDD = 4.0V, WDT disabled, $-40^{\circ}\text{C}$ to $+85^{\circ}\text{C}$ VDD = 4.0V, WDT disabled, $-40^{\circ}\text{C}$ to $+125^{\circ}\text{C}$
D022* D022A*	$\Delta\text{IWDT}$ $\Delta\text{IBOR}$	<b>Module Differential Current</b> (Note 6) Watchdog Timer Brown-out Reset	- -	6.0 350	20 425	$\mu\text{A}$ $\mu\text{A}$	WDTE bit set, VDD = 4.0V BODEN bit set, VDD = 5.0V

\* These parameters are characterized but not tested.

† Data in "Typ" column is at 5V, 25°C unless otherwise stated. These parameters are for design guidance only and are not tested.

Note1: This is the limit to which VDD can be lowered without losing RAM data.

2: The supply current is mainly a function of the operating voltage and frequency. Other factors such as I/O pin loading and switching rate, oscillator type, internal code execution pattern, and temperature also have an impact on the current consumption.

The test conditions for all IDD measurements in active operation mode are:

OSC1 = external square wave, from rail to rail; all I/O pins tristated, pulled to VDD,

MCLR = VDD; WDT enabled/disabled as specified.

3: The power-down current in SLEEP mode does not depend on the oscillator type. Power-down current is measured with the part in SLEEP mode, with all I/O pins in hi-impedance state and tied to VDD and VSS.

4: For RC osc mode, current through Rext is not included. The current through the resistor can be estimated by the formula  $I_r = V_{DD}/2R_{ext}$  (mA) with Rext in kOhm.

5: Timer1 oscillator (when enabled) adds approximately 20  $\mu\text{A}$  to the specification. This value is from characterization and is for design guidance only. This is not tested.

6: The  $\Delta$  current is the additional current consumed when this peripheral is enabled. This current should be added to the base IDD or IPD measurement.

7: When BOR is enabled, the device will operate correctly until the VBOR voltage trip point is reached.

# PIC16C63A/65B/73B/74B

## 14.2 DC Characteristics: PIC16LC63A/65B/73B/74B-04 (Commercial, Industrial)

DC CHARACTERISTICS		Standard Operating Conditions (unless otherwise stated)					
		Operating temperature $0^{\circ}\text{C} \leq T_A \leq +70^{\circ}\text{C}$ for commercial $-40^{\circ}\text{C} \leq T_A \leq +85^{\circ}\text{C}$ for industrial					
Param No.	Sym	Characteristic	Min	Typ†	Max	Units	Conditions
D001	VDD	<b>Supply Voltage</b>	2.5 VBOR*	- -	5.5 5.5	V V	LP, XT, RC osc modes (DC - 4 MHz) BOR enabled (Note 7)
D002*	VDR	<b>RAM Data Retention Voltage</b> (Note 1)	-	1.5	-	V	
D003	VPOR	<b>VDD Start Voltage</b> to ensure internal Power-on Reset signal	-	VSS	-	V	See section on Power-on Reset for details
D004* D004A*	SVDD	<b>VDD Rise Rate</b> to ensure internal Power-on Reset signal	0.05 TBD	- -	- -	V/ms	PWRT enabled (PWRT $\overline{\text{E}}$ bit clear) PWRT disabled (PWRT $\overline{\text{E}}$ bit set) See section on Power-on Reset for details
D005	VBOR	<b>Brown-out Reset</b> voltage trip point	3.65	-	4.35	V	BODEN bit set
D010  D010A	IDD	<b>Supply Current</b> (Note 2, 5)	-  -	2.0  22.5	3.8  48	mA  $\mu\text{A}$	XT, RC osc modes FOSC = 4 MHz, VDD = 3.0V (Note 4)  LP osc mode FOSC = 32 kHz, VDD = 3.0V, WDT disabled
D020 D021 D021A	IPD	<b>Power-down Current</b> (Note 3, 5)	- - -	7.5 0.9 0.9	30 5 5	$\mu\text{A}$ $\mu\text{A}$ $\mu\text{A}$	VDD = 3.0V, WDT enabled, $-40^{\circ}\text{C}$ to $+85^{\circ}\text{C}$ VDD = 3.0V, WDT disabled, $0^{\circ}\text{C}$ to $+70^{\circ}\text{C}$ VDD = 3.0V, WDT disabled, $-40^{\circ}\text{C}$ to $+85^{\circ}\text{C}$
D022* D022A*	$\Delta\text{IWDT}$ $\Delta\text{IBOR}$	<b>Module Differential Current</b> (Note 6) Watchdog Timer Brown-out Reset	- -	6.0 350	20 425	$\mu\text{A}$ $\mu\text{A}$	WDT $\overline{\text{E}}$ bit set, VDD = 4.0V BODEN bit set, VDD = 5.0V

\* These parameters are characterized but not tested.

† Data in "Typ" column is at 5V, 25°C unless otherwise stated. These parameters are for design guidance only and are not tested.

Note1: This is the limit to which VDD can be lowered without losing RAM data.

2: The supply current is mainly a function of the operating voltage and frequency. Other factors such as I/O pin loading and switching rate, oscillator type, internal code execution pattern, and temperature also have an impact on the current consumption.

The test conditions for all IDD measurements in active operation mode are:

OSC1 = external square wave, from rail to rail; all I/O pins tristated, pulled to VDD,

MCLR = VDD; WDT enabled/disabled as specified.

3: The power-down current in SLEEP mode does not depend on the oscillator type. Power-down current is measured with the part in SLEEP mode, with all I/O pins in hi-impedance state and tied to VDD and VSS.

4: For RC osc mode, current through Rext is not included. The current through the resistor can be estimated by the formula  $I_r = V_{DD}/2R_{ext}$  (mA) with Rext in kOhm.

5: Timer1 oscillator (when enabled) adds approximately 20  $\mu\text{A}$  to the specification. This value is from characterization and is for design guidance only. This is not tested.

6: The  $\Delta$  current is the additional current consumed when this peripheral is enabled. This current should be added to the base IDD or IPD measurement.

7: When BOR is enabled, the device will operate correctly until the VBOR voltage trip point is reached..

# PIC16C63A/65B/73B/74B

## 14.3 DC Characteristics: PIC16C63A/65B/73B/74B-04 (Commercial, Industrial, Extended) PIC16C63A/65B/73B/74B-20 (Commercial, Industrial, Extended) PIC16LC63A/65B/73B/74B-04 (Commercial, Industrial)

Standard Operating Conditions (unless otherwise stated)							
DC CHARACTERISTICS							
		Operating temperature $0^{\circ}\text{C} \leq T_A \leq +70^{\circ}\text{C}$ for commercial $-40^{\circ}\text{C} \leq T_A \leq +85^{\circ}\text{C}$ for industrial $-40^{\circ}\text{C} \leq T_A \leq +125^{\circ}\text{C}$ for extended					
		Operating voltage $V_{DD}$ range as described in DC spec Section 14.1 and Section 14.2					
Param No.	Sym	Characteristic	Min	Typ†	Max	Units	Conditions
D030 D030A D031 D032 D033	$V_{IL}$	<b>Input Low Voltage</b> I/O ports with TTL buffer  with Schmitt Trigger buffer MCLR, OSC1 (in RC mode) OSC1 (in XT, HS and LP modes)	$V_{SS}$ $V_{SS}$ $V_{SS}$ $V_{SS}$ $V_{SS}$	- - - - -	$0.15V_{DD}$ 0.8V $0.2V_{DD}$ $0.2V_{DD}$ $0.3V_{DD}$	V V V V V	For entire $V_{DD}$ range $4.5V \leq V_{DD} \leq 5.5V$   Note1
D040 D040A  D041 D042 D042A D043	$V_{IH}$	<b>Input High Voltage</b> I/O ports with TTL buffer  with Schmitt Trigger buffer MCLR OSC1 (XT, HS and LP modes) OSC1 (in RC mode)	2.0 $0.25V_{DD} + 0.8V$  0.8VDD 0.8VDD 0.7VDD 0.9VDD	- - - - - -	$V_{DD}$ $V_{DD}$ $V_{DD}$ $V_{DD}$ $V_{DD}$ $V_{DD}$	V V V V V V	$4.5V \leq V_{DD} \leq 5.5V$ For entire $V_{DD}$ range  For entire $V_{DD}$ range  Note1
D060 D061 D063	$I_{IL}$	<b>Input Leakage Current</b> (Notes 2, 3) I/O ports  MCLR, RA4/T0CKI OSC1	- - -	- - -	$\pm 1$ $\pm 5$ $\pm 5$	$\mu\text{A}$ $\mu\text{A}$ $\mu\text{A}$	$V_{SS} \leq V_{PIN} \leq V_{DD}$ , Pin at hi-impedance $V_{SS} \leq V_{PIN} \leq V_{DD}$ $V_{SS} \leq V_{PIN} \leq V_{DD}$ , XT, HS and LP osc modes
D070	IPURB	<b>PORTB weak pull-up current</b>	50	250	400	$\mu\text{A}$	$V_{DD} = 5V$ , $V_{PIN} = V_{SS}$
D080  D083	$V_{OL}$	<b>Output Low Voltage</b> I/O ports  OSC2/CLKOUT (RC osc mode)	- - - -	- - - -	0.6 0.6 0.6 0.6	V V V V	$I_{OL} = 8.5\text{ mA}$ , $V_{DD} = 4.5V$ , $-40^{\circ}\text{C}$ to $+85^{\circ}\text{C}$ $I_{OL} = 7.0\text{ mA}$ , $V_{DD} = 4.5V$ , $-40^{\circ}\text{C}$ to $+125^{\circ}\text{C}$ $I_{OL} = 1.6\text{ mA}$ , $V_{DD} = 4.5V$ , $-40^{\circ}\text{C}$ to $+85^{\circ}\text{C}$ $I_{OL} = 1.2\text{ mA}$ , $V_{DD} = 4.5V$ , $-40^{\circ}\text{C}$ to $+125^{\circ}\text{C}$

\* These parameters are characterized but not tested.

† Data in "Typ" column is at 5V, 25°C unless otherwise stated. These parameters are for design guidance only and are not tested.

Note1: In RC oscillator mode, the OSC1/CLKIN pin is a Schmitt Trigger input. It is not recommended that the PICmicro be driven with external clock in RC mode.

2: The leakage current on the MCLR/VPP pin is strongly dependent on the applied voltage level. The specified levels represent normal operating conditions. Higher leakage current may be measured at different input voltages.

3: Negative current is defined as current sourced by the pin.



# PIC16C63A/65B/73B/74B

<b>DC CHARACTERISTICS</b>							
<b>Standard Operating Conditions (unless otherwise stated)</b>							
Operating temperature $0^{\circ}\text{C} \leq T_A \leq +70^{\circ}\text{C}$ for commercial $-40^{\circ}\text{C} \leq T_A \leq +85^{\circ}\text{C}$ for industrial $-40^{\circ}\text{C} \leq T_A \leq +125^{\circ}\text{C}$ for extended							
Operating voltage $V_{DD}$ range as described in DC spec Section 14.1 and Section 14.2							
Param No.	Sym	Characteristic	Min	Typ†	Max	Units	Conditions
D090	VOH	<b>Output High Voltage</b> I/O ports (Note 3)	VDD-0.7	-	-	V	IOH = -3.0 mA, VDD = 4.5V, -40°C to +85°C
D092		OSC2/CLKOUT (RC osc mode)	VDD-0.7	-	-	V	IOH = -2.5 mA, VDD = 4.5V, -40°C to +125°C
			VDD-0.7	-	-	V	IOH = -1.3 mA, VDD = 4.5V, -40°C to +85°C
			VDD-0.7	-	-	V	IOH = -1.0 mA, VDD = 4.5V, -40°C to +125°C
D150*	VOD	<b>Open-Drain High Voltage</b>	-	-	8.5	V	RA4 pin
		<b>Capacitive Loading Specs on Output Pins</b>					
D100	COsc2	OSC2 pin	-	-	15	pF	In XT, HS and LP modes when external clock is used to drive OSC1.
D101	CIo	All I/O pins and OSC2 (in RC mode)	-	-	50	pF	
D102	Cb	SCL, SDA in I <sup>2</sup> C mode	-	-	400	pF	

\* These parameters are characterized but not tested.

† Data in "Typ" column is at 5V, 25°C unless otherwise stated. These parameters are for design guidance only and are not tested.

Note1: In RC oscillator mode, the OSC1/CLKIN pin is a Schmitt Trigger input. It is not recommended that the PICmicro be driven with external clock in RC mode.

2: The leakage current on the  $\overline{\text{MCLR}}/V_{PP}$  pin is strongly dependent on the applied voltage level. The specified levels represent normal operating conditions. Higher leakage current may be measured at different input voltages.

3: Negative current is defined as current sourced by the pin.

# PIC16C63A/65B/73B/74B

## 14.4 AC (Timing) Characteristics

### 14.4.1 TIMING PARAMETER SYMBOLOGY

The timing parameter symbols have been created following one of the following formats:

- |             |           |  |
|-------------|-----------|--|
| 1. TppS2ppS | 3. Tcc:ST | (I <sup>2</sup> C specifications only) |
| 2. TppS     | 4. Ts     | (I <sup>2</sup> C specifications only) |

<b>T</b>			
F	Frequency	T	Time

Lowercase letters (pp) and their meanings:

<b>pp</b>			
cc	CCP1	osc	OSC1
ck	CLKOUT	rd	$\overline{RD}$
cs	$\overline{CS}$	rw	$\overline{RD}$ or $\overline{WR}$
di	SDI	sc	SCK
do	SDO	ss	$\overline{SS}$
dt	Data in	t0	T0CKI
io	I/O port	t1	T1CKI
mc	$\overline{MCLR}$	wr	$\overline{WR}$

Uppercase letters and their meanings:

<b>S</b>			
F	Fall	P	Period
H	High	R	Rise
I	Invalid (Hi-impedance)	V	Valid
L	Low	Z	Hi-impedance
<b>I<sup>2</sup>C only</b>			
AA	output access	High	High
BUF	Bus free	Low	Low

Tcc:ST (I<sup>2</sup>C specifications only)

<b>CC</b>			
HD	Hold	SU	Setup
<b>ST</b>			
DAT	DATA input hold	STO	STOP condition
STA	START condition		

# PIC16C63A/65B/73B/74B

## 14.4.2 TIMING CONDITIONS

The temperature and voltages specified in Table 14-1 apply to all timing specifications unless otherwise noted. Figure 14-1 specifies the load conditions for the timing specifications.

**TABLE 14-1: TEMPERATURE AND VOLTAGE SPECIFICATIONS - AC**

Standard Operating Conditions (unless otherwise stated)	
AC CHARACTERISTICS	Operating temperature $0^{\circ}\text{C} \leq T_A \leq +70^{\circ}\text{C}$ for commercial
	$-40^{\circ}\text{C} \leq T_A \leq +85^{\circ}\text{C}$ for industrial
	$-40^{\circ}\text{C} \leq T_A \leq +125^{\circ}\text{C}$ for extended
Operating voltage $V_{DD}$ range as described in DC spec Section 14.1 and Section 14.2.	
LC parts operate for commercial/industrial temp's only.	

**FIGURE 14-1: LOAD CONDITIONS FOR DEVICE TIMING SPECIFICATIONS**

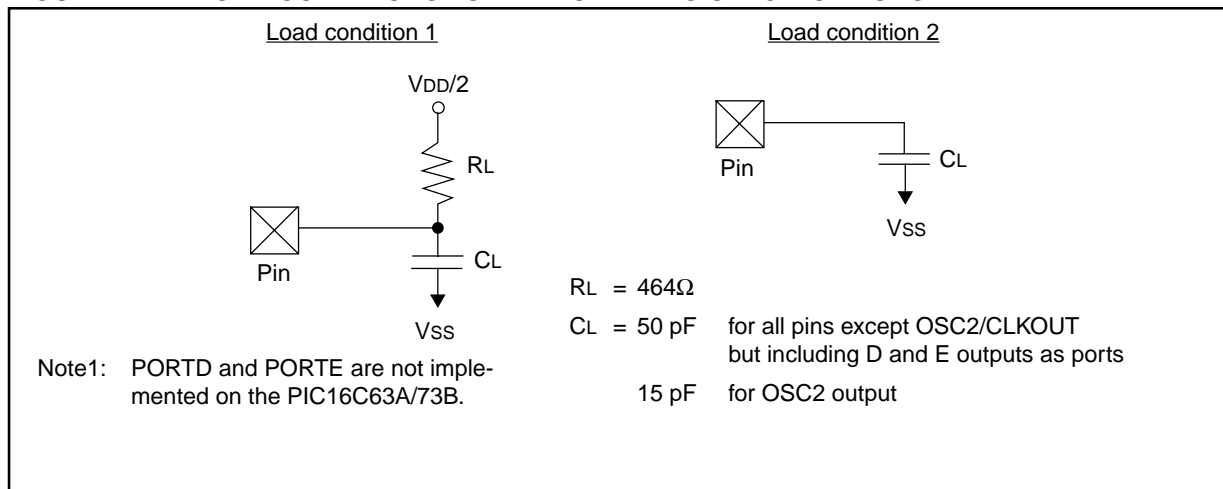

# PIC16C63A/65B/73B/74B

## 14.4.3 TIMING DIAGRAMS AND SPECIFICATIONS

**FIGURE 14-2: EXTERNAL CLOCK TIMING**

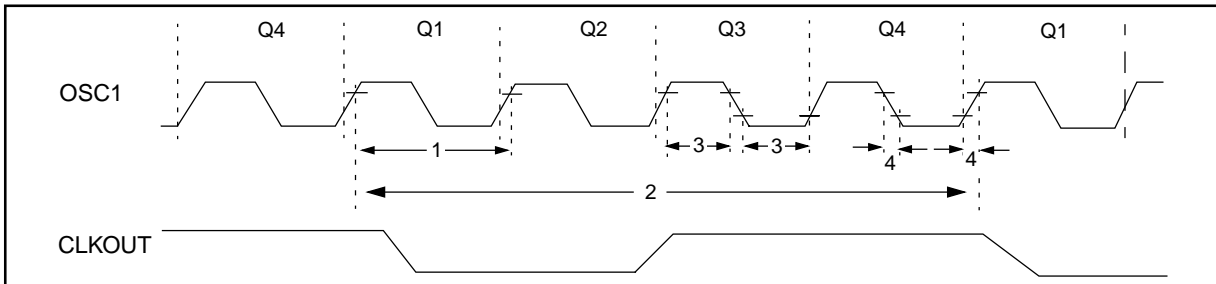

**TABLE 14-2: EXTERNAL CLOCK TIMING REQUIREMENTS**

Param No.	Sym	Characteristic	Min	Typ†	Max	Units	Conditions
1A	Fosc	<b>External CLKIN Frequency</b> (Note 1)	DC	—	4	MHz	RC and XT osc modes
			DC	—	4	MHz	HS osc mode (-04)
			DC	—	20	MHz	HS osc mode (-20)
			DC	—	200	kHz	LP osc mode
		<b>Oscillator Frequency</b> (Note 1)	DC	—	4	MHz	RC osc mode
			0.1	—	4	MHz	XT osc mode
			4	—	20	MHz	HS osc mode
			5	—	200	kHz	LP osc mode
1	Tosc	<b>External CLKIN Period</b> (Note 1)	250	—	—	ns	RC and XT osc modes
			250	—	—	ns	HS osc mode (-04)
			50	—	—	ns	HS osc mode (-20)
			5	—	—	μs	LP osc mode
		<b>Oscillator Period</b> (Note 1)	250	—	—	ns	RC osc mode
			250	—	10,000	ns	XT osc mode
			250	—	250	ns	HS osc mode (-04)
			50	—	250	ns	HS osc mode (-20)
			5	—	—	μs	LP osc mode
2	Tcy	<b>Instruction Cycle Time</b> (Note 1)	200	—	DC	ns	Tcy = 4/Fosc
3*	TosL, TosH	<b>External Clock in (OSC1) High or Low Time</b>	100	—	—	ns	XT oscillator
			2.5	—	—	μs	LP oscillator
			15	—	—	ns	HS oscillator
4*	TosR, TosF	<b>External Clock in (OSC1) Rise or Fall Time</b>	—	—	25	ns	XT oscillator
			—	—	50	ns	LP oscillator
			—	—	15	ns	HS oscillator

\* These parameters are characterized but not tested.

† Data in "Typ" column is at 5V, 25°C unless otherwise stated. These parameters are for design guidance only and are not tested.

Note1: Instruction cycle period (Tcy) equals four times the input oscillator time-base period. All specified values are based on characterization data for that particular oscillator type under standard operating conditions with the device executing code. Exceeding these specified limits may result in an unstable oscillator operation and/or higher than expected current consumption. All devices are tested to operate at "min." values with an external clock applied to the OSC1/CLKIN pin.

When an external clock input is used, the "Max." cycle time limit is "DC" (no clock) for all devices.

# PIC16C63A/65B/73B/74B

**FIGURE 14-3: CLKOUT AND I/O TIMING**

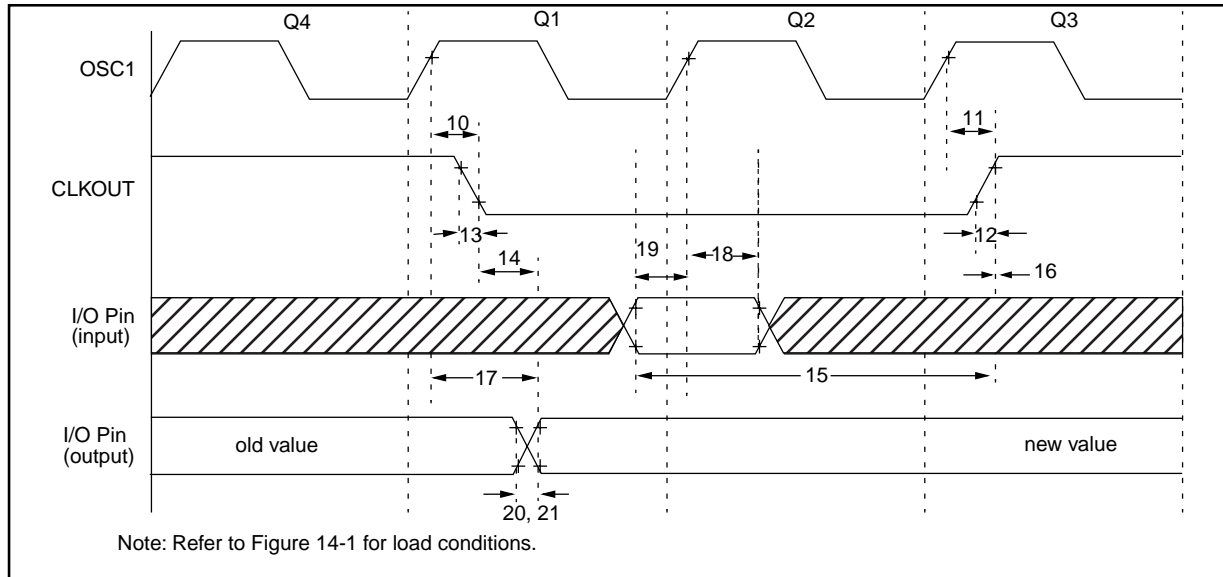

**TABLE 14-3: CLKOUT AND I/O TIMING REQUIREMENTS**

Param No.	Sym	Characteristic	Min	Typ†	Max	Units	Conditions
10*	TosH2ckL	OSC1↑ to CLKOUT↓	—	75	200	ns	Note 1
11*	TosH2ckH	OSC1↑ to CLKOUT↑	—	75	200	ns	Note 1
12*	TckR	CLKOUT rise time	—	35	100	ns	Note 1
13*	TckF	CLKOUT fall time	—	35	100	ns	Note 1
14*	TckL2ioV	CLKOUT ↓ to Port out valid	—	—	0.5TCY + 20	ns	Note 1
15*	TioV2ckH	Port in valid before CLKOUT ↑	Tosc + 200	—	—	ns	Note 1
16*	TckH2ioI	Port in hold after CLKOUT ↑	0	—	—	ns	Note 1
17*	TosH2ioV	OSC1↑ (Q1 cycle) to Port out valid	—	50	150	ns	
18*	TosH2ioI	OSC1↑ (Q2 cycle) to Port input invalid (I/O in hold time)	Standard	100	—	—	ns
18A*			Extended (LC)	200	—	—	ns
19*	TioV2osH	Port input valid to OSC1↑ (I/O in setup time)	0	—	—	ns	
20*	TioR	Port output rise time	Standard	—	10	40	ns
20A*			Extended (LC)	—	—	80	ns
21*	TioF	Port output fall time	Standard	—	10	40	ns
21A*			Extended (LC)	—	—	80	ns
22††*	Tinp	INT pin high or low time	TCY	—	—	ns	
23††*	Trbp	RB7:RB4 change INT high or low time	TCY	—	—	ns	

\* These parameters are characterized but not tested.

† Data in "Typ" column is at 5V, 25°C unless otherwise stated. These parameters are for design guidance only and are not tested.

†† These parameters are asynchronous events not related to any internal clock edge.

Note1: Measurements are taken in RC Mode where CLKOUT output is 4 x Tosc.

# PIC16C63A/65B/73B/74B

**FIGURE 14-4: RESET, WATCHDOG TIMER, OSCILLATOR START-UP TIMER AND POWER-UP TIMER TIMING**

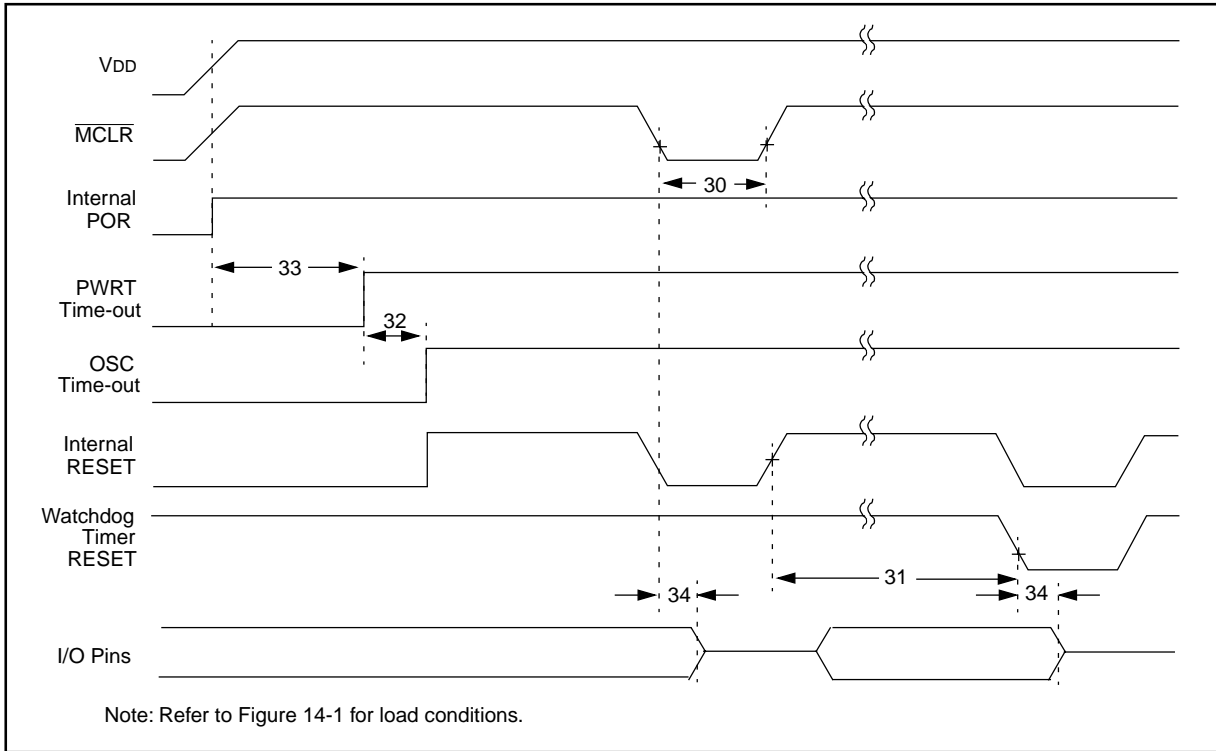

**FIGURE 14-5: BROWN-OUT RESET TIMING**



**TABLE 14-4: RESET, WATCHDOG TIMER, OSCILLATOR START-UP TIMER, POWER-UP TIMER, AND BROWN-OUT RESET REQUIREMENTS**

Parameter No.	Sym	Characteristic	Min	Typ†	Max	Units	Conditions
30	Tmcl	MCLR Pulse Width (low)	2	—	—	μs	VDD = 5V, -40°C to +125°C
31*	Twdt	Watchdog Timer Time-out Period (No Prescaler)	7	18	33	ms	VDD = 5V, -40°C to +125°C
32	Tost	Oscillation Start-up Timer Period	—	1024 T <sub>osc</sub>	—	—	T <sub>OSC</sub> = OSC1 period
33*	Tpwrt	Power-up Timer Period	28	72	132	ms	VDD = 5V, -40°C to +125°C
34	Tioz	I/O Hi-impedance from MCLR Low or WDT reset	—	—	2.1	μs	
35	TBOR	Brown-out Reset Pulse Width	100	—	—	μs	VDD ≤ BVDD (D005)

\* These parameters are characterized but not tested.

† Data in "Typ" column is at 5V, 25°C unless otherwise stated. These parameters are for design guidance only and are not tested.

# PIC16C63A/65B/73B/74B

**FIGURE 14-6: TIMER0 AND TIMER1 EXTERNAL CLOCK TIMINGS**

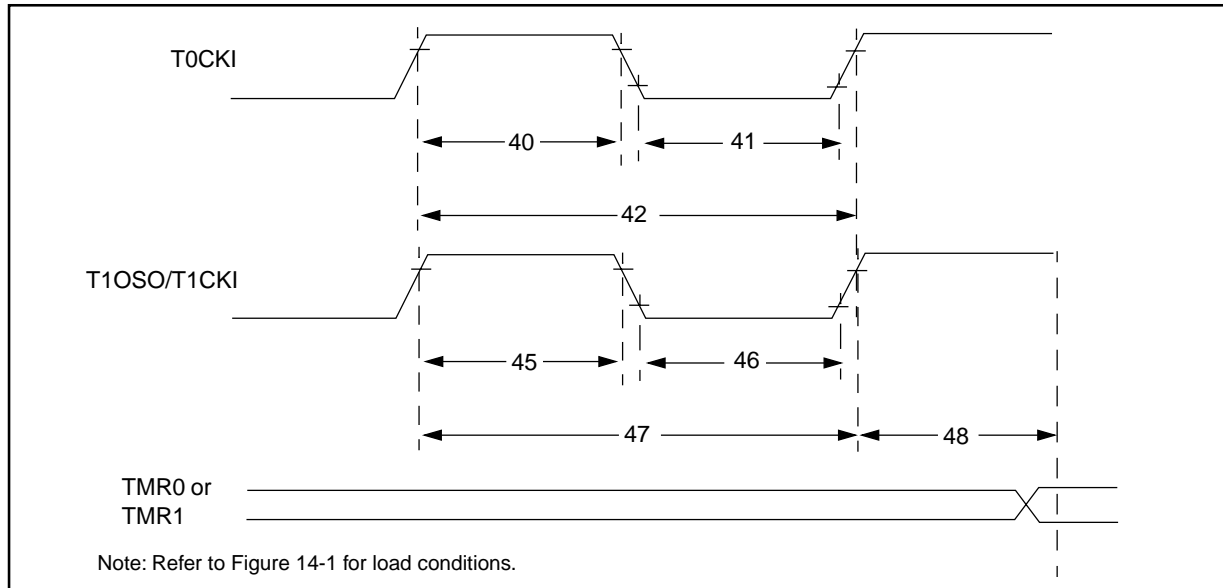

**TABLE 14-5: TIMER0 AND TIMER1 EXTERNAL CLOCK REQUIREMENTS**

Param No.	Sym	Characteristic	Min	Typ†	Max	Units	Conditions	
40*	Tt0H	T0CKI High Pulse Width	No Prescaler 0.5TCY + 20 With Prescaler 10	—	—	ns	Must also meet parameter 42	
41*	Tt0L	T0CKI Low Pulse Width	No Prescaler 0.5TCY + 20 With Prescaler 10	—	—	ns		
42*	Tt0P	T0CKI Period	No Prescaler TCY + 40 With Prescaler Greater of: 20 or $\frac{TCY + 40}{N}$	—	—	ns	N = prescale value (2, 4, ..., 256)	
45*	Tt1H	T1CKI High Time	Synchronous, Prescaler = 1 Standard	0.5TCY + 20 15	—	—	ns	Must also meet parameter 47
			Synchronous, Prescaler = 2,4,8 Extended (LC)	25	—	—	ns	
			Asynchronous Standard	30	—	—	ns	
			Asynchronous Extended (LC)	50	—	—	ns	
46*	Tt1L	T1CKI Low Time	Synchronous, Prescaler = 1 Standard	0.5TCY + 20 15	—	—	ns	Must also meet parameter 47
			Synchronous, Prescaler = 2,4,8 Extended (LC)	25	—	—	ns	
			Asynchronous Standard	30	—	—	ns	
			Asynchronous Extended (LC)	50	—	—	ns	
47*	Tt1P	T1CKI input period	Synchronous Standard	Greater of: 30 OR $\frac{TCY + 40}{N}$	—	—	ns	N = prescale value (1, 2, 4, 8)
			Synchronous Extended (LC)	Greater of: 50 OR $\frac{TCY + 40}{N}$	—	—	ns	N = prescale value (1, 2, 4, 8)
			Asynchronous Standard	60	—	—	ns	
			Asynchronous Extended (LC)	100	—	—	ns	
	Ft1	Timer1 oscillator input frequency range (oscillator enabled by setting bit T1OSCEN)	DC	—	200	kHz		
48	TCKEZtmr1	Delay from external clock edge to timer increment	2Tosc	—	7Tosc	—		

\* These parameters are characterized but not tested.

† Data in "Typ" column is at 5V, 25°C unless otherwise stated. These parameters are for design guidance only and are not tested.

# PIC16C63A/65B/73B/74B

**FIGURE 14-7: CAPTURE/COMPARE/PWM TIMINGS (CCP1 AND CCP2)**

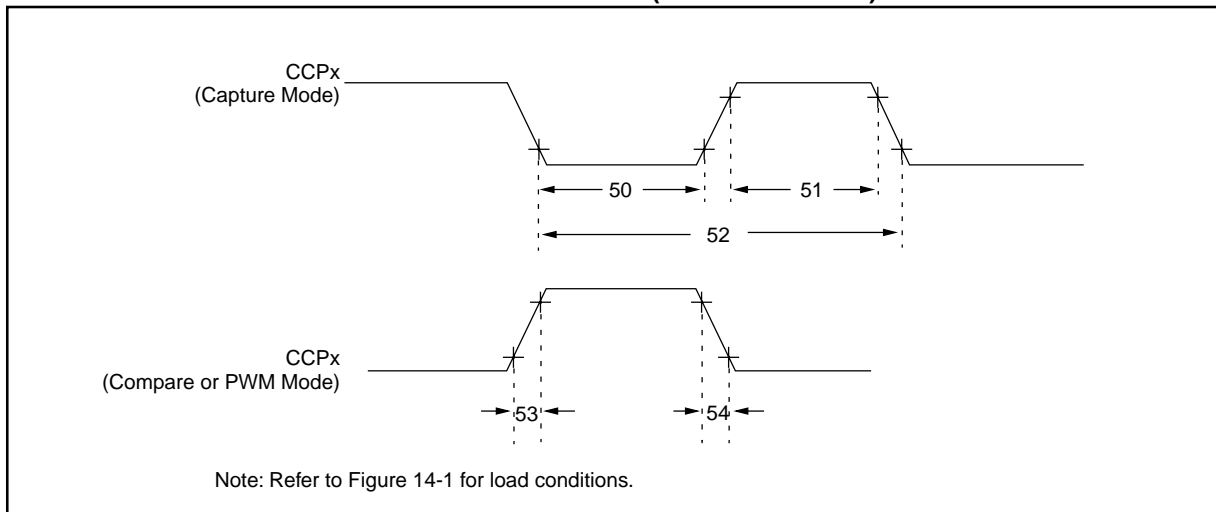

**TABLE 14-6: CAPTURE/COMPARE/PWM REQUIREMENTS (CCP1 AND CCP2)**

Param No.	Sym	Characteristic	Min	Typ†	Max	Units	Conditions	
50*	TccL	CCP1 and CCP2 input low time	No Prescaler	$0.5T_{CY} + 20$	—	—	ns	
			With Prescaler	Standard	10	—	—	ns
				Extended (LC)	20	—	—	ns
51*	TccH	CCP1 and CCP2 input high time	No Prescaler	$0.5T_{CY} + 20$	—	—	ns	
			With Prescaler	Standard	10	—	—	ns
				Extended (LC)	20	—	—	ns
52*	TccP	CCP1 and CCP2 input period	$\frac{3T_{CY} + 40}{N}$	—	—	ns	N = prescale value (1, 4, or 16)	
53*	TccR	CCP1 and CCP2 output rise time	Standard	—	10	25	ns	
			Extended (LC)	—	25	45	ns	
54*	TccF	CCP1 and CCP2 output fall time	Standard	—	10	25	ns	
			Extended (LC)	—	25	45	ns	

\* These parameters are characterized but not tested.

† Data in "Typ" column is at 5V, 25°C unless otherwise stated. These parameters are for design guidance only and are not tested.



# PIC16C63A/65B/73B/74B

**FIGURE 14-8: PARALLEL SLAVE PORT TIMING (PIC16C65B/74B)**

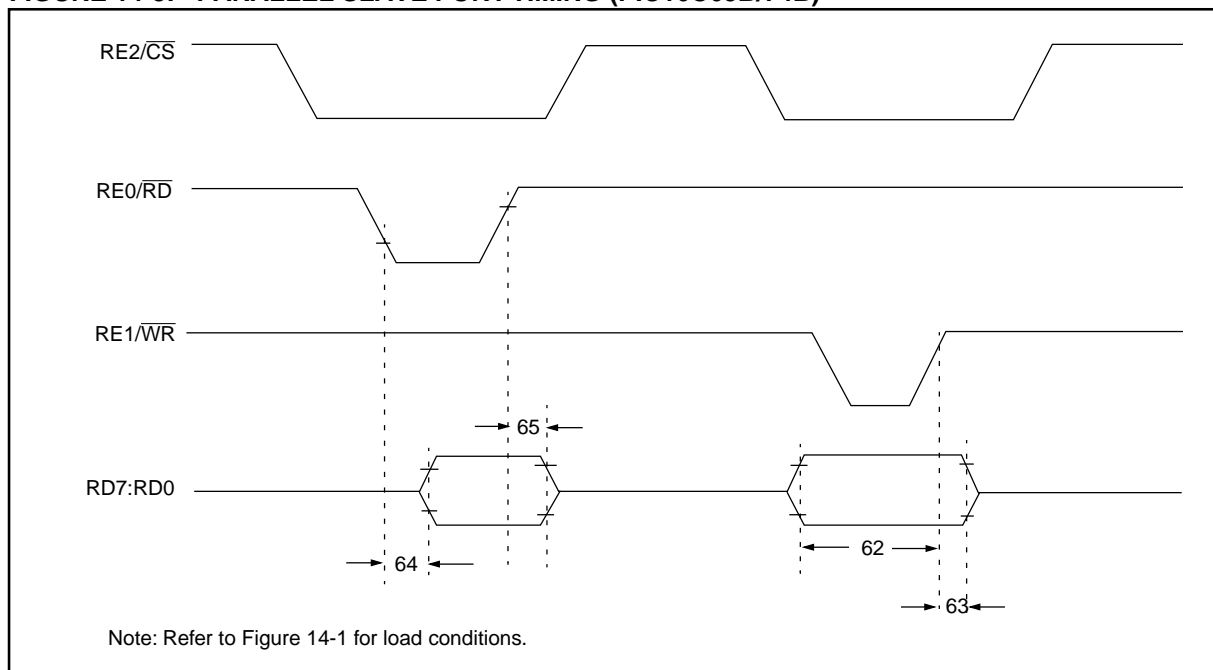

**TABLE 14-7: PARALLEL SLAVE PORT REQUIREMENTS (PIC16C65B/74B)**

Parameter No.	Sym	Characteristic	Min	Typ†	Max	Units	Conditions
62*	TdtV2wrH	Data in valid before $\overline{WR}\uparrow$ or $\overline{CS}\uparrow$ (setup time)	20	—	—	ns	
63*	TwrH2dtl	$\overline{WR}\uparrow$ or $\overline{CS}\uparrow$ to data-in invalid (hold time)	Standard	20	—	—	ns
			Extended (LC)	35	—	—	ns
64	TrdL2dtV	$\overline{RD}\downarrow$ and $\overline{CS}\downarrow$ to data-out valid	—	—	80	ns	
65*	TrdH2dtl	$\overline{RD}\uparrow$ or $\overline{CS}\uparrow$ to data-out invalid	10	—	30	ns	

\* These parameters are characterized but not tested.

† Data in "Typ" column is at 5V, 25°C unless otherwise stated. These parameters are for design guidance only and are not tested.

# PIC16C63A/65B/73B/74B

**FIGURE 14-9: EXAMPLE SPI MASTER MODE TIMING (CKE = 0)**

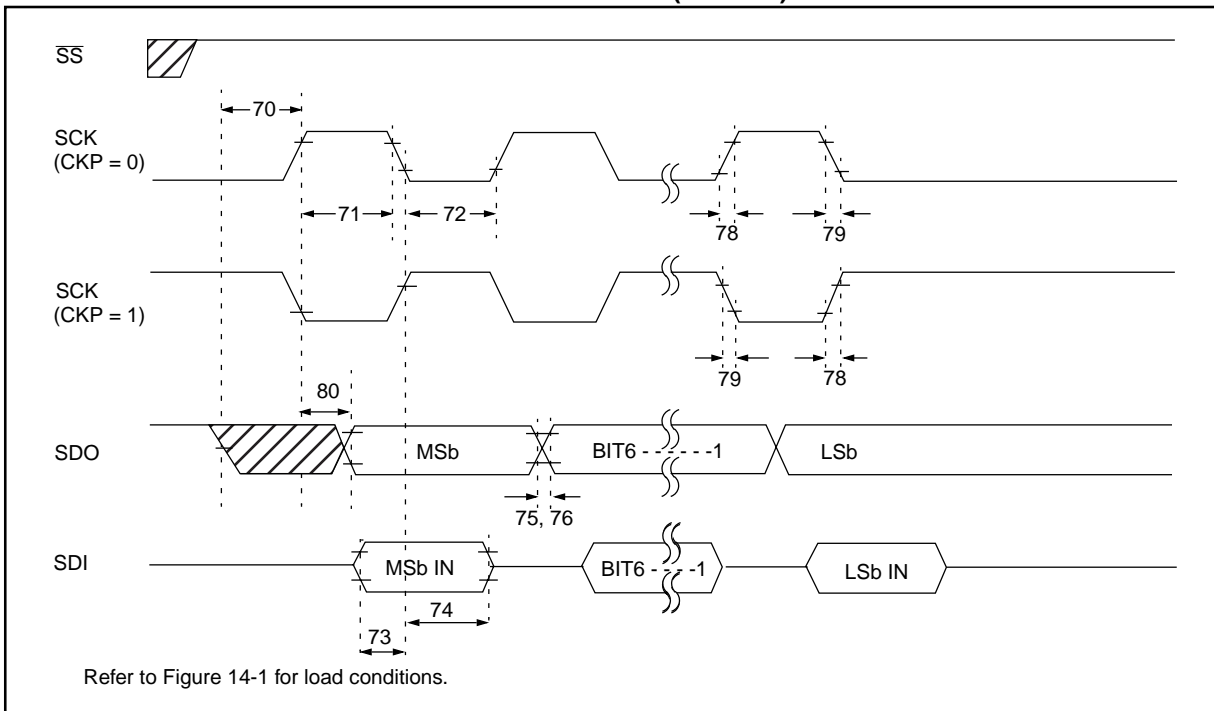

**TABLE 14-8: EXAMPLE SPI MODE REQUIREMENTS (MASTER MODE, CKE = 0)**

Param. No.	Symbol	Characteristic	Min	Typ†	Max	Units	Conditions
70	TssL2scH, TssL2scL	SS↓ to SCK↓ or SCK↑ input	T <sub>CY</sub>	—	—	ns	
71 71A	TscH	SCK input high time (slave mode)	Continuous	1.25T <sub>CY</sub> + 30	—	—	ns
			Single Byte	40	—	—	ns
72 72A	TscL	SCK input low time (slave mode)	Continuous	1.25T <sub>CY</sub> + 30	—	—	ns
			Single Byte	40	—	—	ns
73	TdiV2scH, TdiV2scL	Setup time of SDI data input to SCK edge	100	—	—	ns	
73A	Tb2B	Last clock edge of Byte1 to the 1st clock edge of Byte2	1.5T <sub>CY</sub> + 40	—	—	ns	Note 1
74	Tsch2diL, TscL2diL	Hold time of SDI data input to SCK edge	100	—	—	ns	
75	TdoR	SDO data output rise time	Standard	—	10	25	ns
			Extended (LC)	—	20	45	ns
76	TdoF	SDO data output fall time	—	10	25	ns	
78	TscR	SCK output rise time (master mode)	Standard	—	10	25	ns
			Extended (LC)	—	20	45	ns
79	TscF	SCK output fall time (master mode)	—	10	25	ns	
80	Tsch2doV, TscL2doV	SDO data output valid after SCK edge	Standard	—	—	50	ns
			Extended (LC)	—	—	100	ns

† Data in "Typ" column is at 5V, 25°C unless otherwise stated. These parameters are for design guidance only and are not tested.

Note1: Specification 73A is only required if specifications 71A and 72A are used.

# PIC16C63A/65B/73B/74B

**FIGURE 14-10: EXAMPLE SPI MASTER MODE TIMING (CKE = 1)**

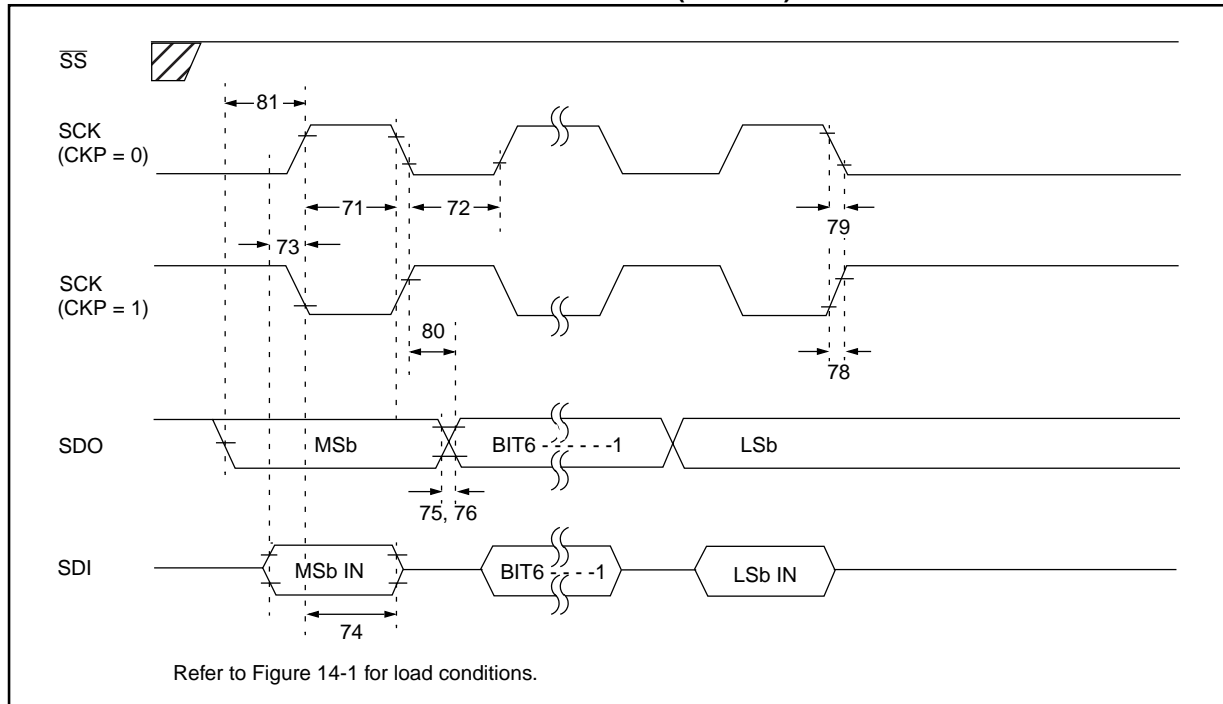

**TABLE 14-9: EXAMPLE SPI MODE REQUIREMENTS (MASTER MODE, CKE = 1)**

Param. No.	Symbol	Characteristic	Min	Typ†	Max	Units	Conditions
71	TscH	SCK input high time (slave mode)	Continuous	1.25TCY + 30	—	—	ns
71A			Single Byte	40	—	—	ns
72	TscL	SCK input low time (slave mode)	Continuous	1.25TCY + 30	—	—	ns
72A			Single Byte	40	—	—	ns
73	TdiV2scH, TdiV2scL	Setup time of SDI data input to SCK edge	100	—	—	ns	
73A	Tb2B	Last clock edge of Byte1 to the 1st clock edge of Byte2	1.5TCY + 40	—	—	ns	Note 1
74	Tsch2diL, TscL2diL	Hold time of SDI data input to SCK edge	100	—	—	ns	
75	TdoR	SDO data output rise time	Standard	—	10	25	ns
76			Extended (LC)	—	20	45	ns
76	TdoF	SDO data output fall time	—	10	25	ns	
78	TscR	SCK output rise time (master mode)	Standard	—	10	25	ns
79			Extended (LC)	—	20	45	ns
79	TscF	SCK output fall time (master mode)	—	10	25	ns	
80	Tsch2doV, TscL2doV	SDO data output valid after SCK edge	Standard	—	—	50	ns
81			Extended (LC)	—	—	100	ns
81	TdoV2scH, TdoV2scL	SDO data output setup to SCK edge	TCY	—	—	ns	

† Data in "Typ" column is at 5V, 25°C unless otherwise stated. These parameters are for design guidance only and are not tested.

Note1: Specification 73A is only required if specifications 71A and 72A are used.

# PIC16C63A/65B/73B/74B

FIGURE 14-11: EXAMPLE SPI SLAVE MODE TIMING (CKE = 0)

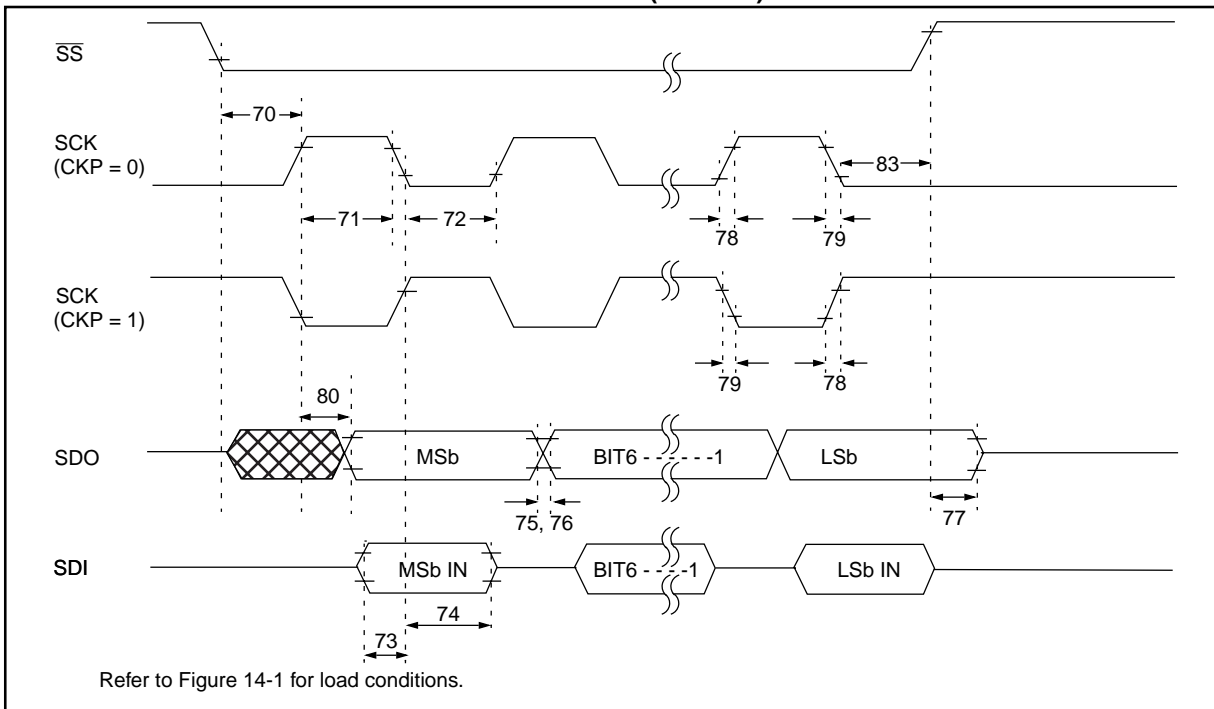

TABLE 14-10: EXAMPLE SPI MODE REQUIREMENTS (SLAVE MODE TIMING (CKE = 0))

Param. No.	Symbol	Characteristic	Min	Typ†	Max	Units	Conditions
70	TssL2scH, TssL2scL	SS↓ to SCK↓ or SCK↑ input	T <sub>CY</sub>	—	—	ns	
71	TscH	SCK input high time (slave mode)	Continuous	1.25T <sub>CY</sub> + 30	—	—	ns
71A			Single Byte	40	—	—	ns
72	TscL	SCK input low time (slave mode)	Continuous	1.25T <sub>CY</sub> + 30	—	—	ns
72A			Single Byte	40	—	—	ns
73	TdiV2scH, TdiV2scL	Setup time of SDI data input to SCK edge	100	—	—	ns	
73A	Tb2B	Last clock edge of Byte1 to the 1st clock edge of Byte2	1.5T <sub>CY</sub> + 40	—	—	ns	Note 1
74	TscH2diL, TscL2diL	Hold time of SDI data input to SCK edge	100	—	—	ns	
75	TdoR	SDO data output rise time	Standard	—	10	25	ns
			Extended (LC)	—	20	45	ns
76	TdoF	SDO data output fall time	—	10	25	ns	
77	TssH2doZ	SS↑ to SDO output hi-impedance	10	—	50	ns	
78	TscR	SCK output rise time (master mode)	Standard	—	10	25	ns
			Extended (LC)	—	20	45	ns
79	TscF	SCK output fall time (master mode)	—	10	25	ns	
80	TscH2doV, TscL2doV	SDO data output valid after SCK edge	Standard	—	—	50	ns
			Extended (LC)	—	—	100	ns
83	TscH2ssH, TscL2ssH	SS↑ after SCK edge	1.5T <sub>CY</sub> + 40	—	—	ns	

† Data in "Typ" column is at 5V, 25°C unless otherwise stated. These parameters are for design guidance only and are not tested.

Note1: Specification 73A is only required if specifications 71A and 72A are used.

# PIC16C63A/65B/73B/74B

**FIGURE 14-12: EXAMPLE SPI SLAVE MODE TIMING (CKE = 1)**

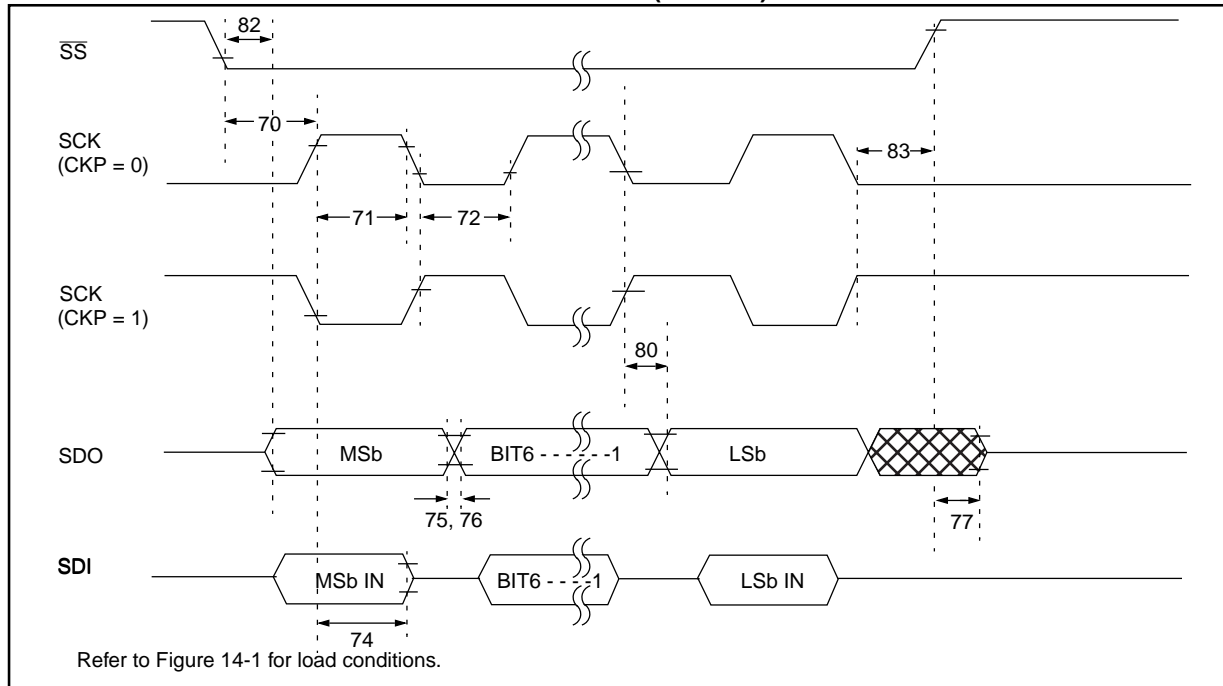

**TABLE 14-11: EXAMPLE SPI SLAVE MODE REQUIREMENTS (CKE = 1)**

Param. No.	Symbol	Characteristic	Min	Typ†	Max	Units	Conditions
70	TssL2scH, TssL2scL	$\overline{SS}\downarrow$ to SCK $\downarrow$ or SCK $\uparrow$ input	T <sub>CY</sub>	—	—	ns	
71 71A	TscH	SCK input high time (slave mode)	Continuous Single Byte	1.25T <sub>CY</sub> + 30 40	— —	ns	Note 1
72 72A	TscL	SCK input low time (slave mode)	Continuous Single Byte	1.25T <sub>CY</sub> + 30 40	— —	ns	Note 1
73A	Tb2B	Last clock edge of Byte1 to the 1st clock edge of Byte2	1.5T <sub>CY</sub> + 40	—	—	ns	Note 1
74	Tsch2diL, TscL2diL	Hold time of SDI data input to SCK edge	100	—	—	ns	
75	TdoR	SDO data output rise time	Standard Extended (LC)	— —	10 20	25 45	ns
76	TdoF	SDO data output fall time	—	—	10	25	ns
77	TssH2doZ	$\overline{SS}\uparrow$ to SDO output hi-impedance	10	—	50	ns	
78	TscR	SCK output rise time (master mode)	Standard Extended (LC)	— —	10 20	25 45	ns
79	TscF	SCK output fall time (master mode)	—	—	10	25	ns
80	Tsch2doV, TscL2doV	SDO data output valid after SCK edge	Standard Extended (LC)	— —	— —	50 100	ns
82	TssL2doV	SDO data output valid after $\overline{SS}\downarrow$ edge	Standard Extended (LC)	— —	— —	50 100	ns
83	Tsch2ssH, TscL2ssH	$\overline{SS}\uparrow$ after SCK edge	1.5T <sub>CY</sub> + 40	—	—	ns	

† Data in "Typ" column is at 5V, 25°C unless otherwise stated. These parameters are for design guidance only and are not tested.

Note1: Specification 73A is only required if specifications 71A and 72A are used.

# PIC16C63A/65B/73B/74B

**FIGURE 14-13: I<sup>2</sup>C BUS START/STOP BITS TIMING**

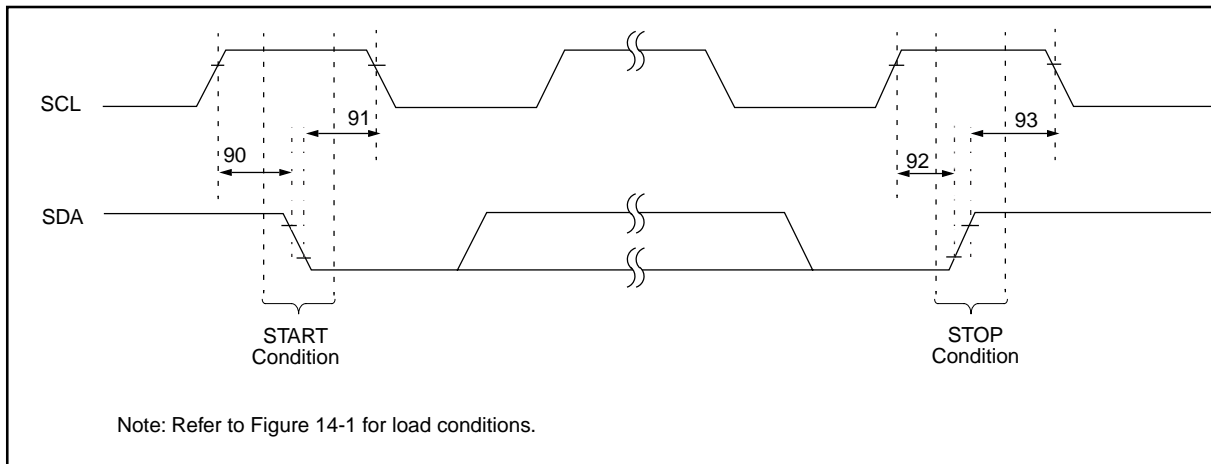

**TABLE 14-12: I<sup>2</sup>C BUS START/STOP BITS REQUIREMENTS**

Parameter No.	Sym	Characteristic	Min	Typ	Max	Units	Conditions	
90*	TSU:STA	START condition	100 kHz mode	4700	—	—	ns	Only relevant for repeated START condition
		Setup time	400 kHz mode	600	—	—		
91*	THD:STA	START condition	100 kHz mode	4000	—	—	ns	After this period the first clock pulse is generated
		Hold time	400 kHz mode	600	—	—		
92*	TSU:STO	STOP condition	100 kHz mode	4700	—	—	ns	
		Setup time	400 kHz mode	600	—	—		
93	THD:STO	STOP condition	100 kHz mode	4000	—	—	ns	
		Hold time	400 kHz mode	600	—	—		

\* These parameters are characterized but not tested.

# PIC16C63A/65B/73B/74B

**FIGURE 14-14: I<sup>2</sup>C BUS DATA TIMING**

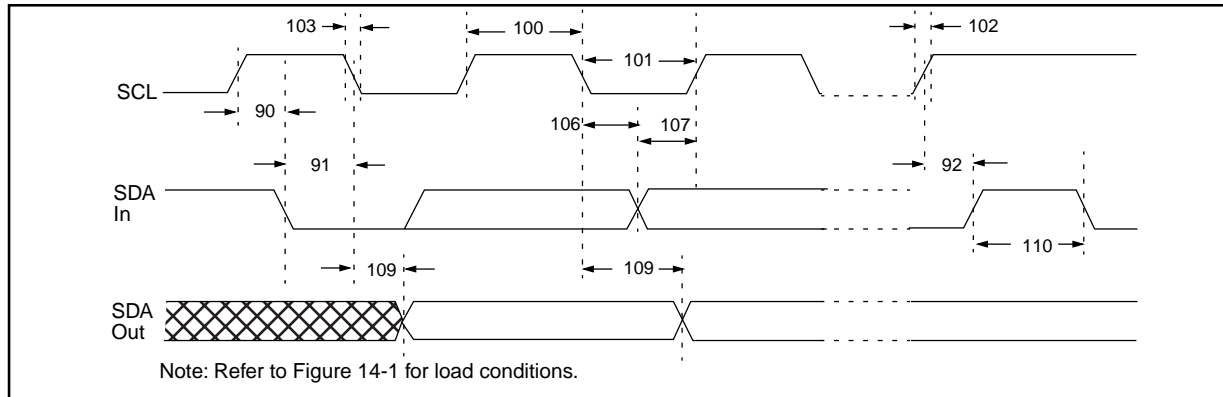

**TABLE 14-13: I<sup>2</sup>C BUS DATA REQUIREMENTS**

Parameter No.	Sym	Characteristic	Min	Max	Units	Conditions	
100*	T <sub>HIGH</sub>	Clock high time	100 kHz mode	4.0	—	μs	Device must operate at a minimum of 1.5 MHz
			400 kHz mode	0.6	—	μs	Device must operate at a minimum of 10 MHz
			SSP Module	1.5T <sub>CY</sub>	—		
101*	T <sub>LOW</sub>	Clock low time	100 kHz mode	4.7	—	μs	Device must operate at a minimum of 1.5 MHz
			400 kHz mode	1.3	—	μs	Device must operate at a minimum of 10 MHz
			SSP Module	1.5T <sub>CY</sub>	—		
102*	T <sub>R</sub>	SDA and SCL rise time	100 kHz mode	—	1000	ns	
			400 kHz mode	20 + 0.1C <sub>b</sub>	300	ns	C <sub>b</sub> is specified to be from 10-400 pF
103*	T <sub>F</sub>	SDA and SCL fall time	100 kHz mode	—	300	ns	
			400 kHz mode	20 + 0.1C <sub>b</sub>	300	ns	C <sub>b</sub> is specified to be from 10-400 pF
90*	T <sub>SU:STA</sub>	START condition setup time	100 kHz mode	4.7	—	μs	Only relevant for repeated START condition
			400 kHz mode	0.6	—	μs	
91*	T <sub>HD:STA</sub>	START condition hold time	100 kHz mode	4.0	—	μs	After this period the first clock pulse is generated
			400 kHz mode	0.6	—	μs	
106*	T <sub>HD:DAT</sub>	Data input hold time	100 kHz mode	0	—	ns	
			400 kHz mode	0	0.9	μs	
107*	T <sub>SU:DAT</sub>	Data input setup time	100 kHz mode	250	—	ns	Note 2
			400 kHz mode	100	—	ns	
92*	T <sub>SU:STO</sub>	STOP condition setup time	100 kHz mode	4.7	—	μs	
			400 kHz mode	0.6	—	μs	
109*	T <sub>AA</sub>	Output valid from clock	100 kHz mode	—	3500	ns	Note 1
			400 kHz mode	—	—	ns	
110*	T <sub>BUF</sub>	Bus free time	100 kHz mode	4.7	—	μs	Time the bus must be free before a new transmission can start
			400 kHz mode	1.3	—	μs	
	C <sub>b</sub>	Bus capacitive loading	—	400	pF		

\* These parameters are characterized but not tested.

- Note1: As a transmitter, the device must provide this internal minimum delay time to bridge the undefined region (min. 300 ns) of the falling edge of SCL to avoid unintended generation of START or STOP conditions.
- 2: A fast-mode (400 kHz) I<sup>2</sup>C-bus device can be used in a standard-mode (100 kHz) I<sup>2</sup>C-bus system, but the requirement T<sub>SU:DAT</sub> ≥ 250 ns must then be met. This will automatically be the case if the device does not stretch the LOW period of the SCL signal. If such a device does stretch the LOW period of the SCL signal, it must output the next data bit to the SDA line T<sub>R</sub> max.+t<sub>SU:DAT</sub> = 1000 + 250 = 1250 ns (according to the standard-mode I<sup>2</sup>C bus specification) before the SCL line is released.

# PIC16C63A/65B/73B/74B

**FIGURE 14-15: USART SYNCHRONOUS TRANSMISSION (MASTER/SLAVE) TIMING**

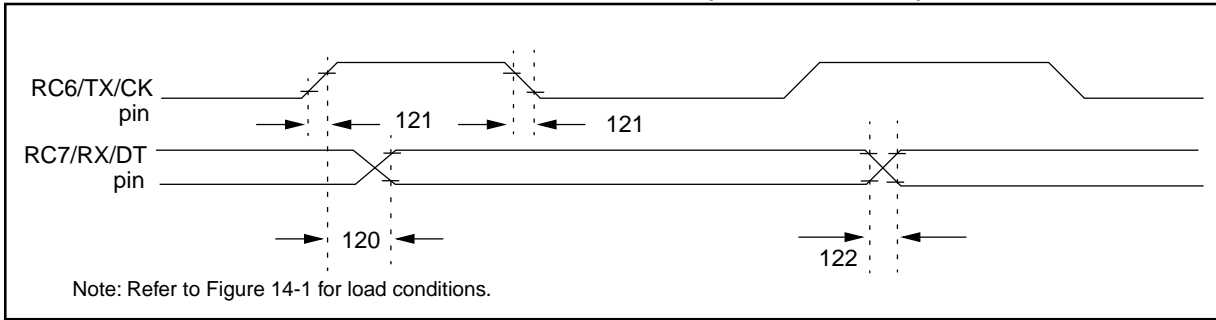

**TABLE 14-14: USART SYNCHRONOUS TRANSMISSION REQUIREMENTS**

Param No.	Sym	Characteristic	Min	Typ†	Max	Units	Conditions
120*	TckH2dtV	SYNC XMIT (MASTER & SLAVE)	—	—	80	ns	
		Clock high to data out valid	—	—	100	ns	
121*	Tckrf	Clock out rise time and fall time (Master Mode)	—	—	45	ns	
			—	—	50	ns	
122*	TdtV	Data out rise time and fall time	—	—	45	ns	
			—	—	50	ns	

\* These parameters are characterized but not tested.

† Data in "Typ" column is at 5V, 25°C unless otherwise stated. These parameters are for design guidance only and are not tested.

**FIGURE 14-16: USART SYNCHRONOUS RECEIVE (MASTER/SLAVE) TIMING**

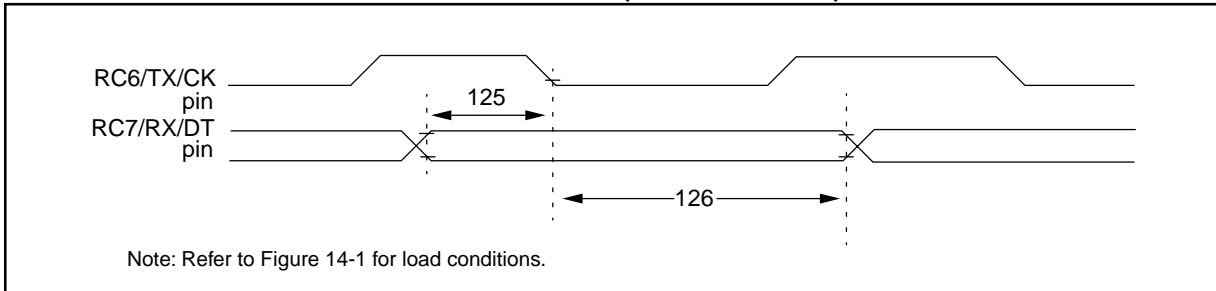

**TABLE 14-15: USART SYNCHRONOUS RECEIVE REQUIREMENTS**

Parameter No.	Sym	Characteristic	Min	Typ†	Max	Units	Conditions
125*	TdtV2ckL	SYNC RCV (MASTER & SLAVE) Data setup before CK ↓ (DT setup time)	15	—	—	ns	
126*	TckL2dtL	Data hold after CK ↓ (DT hold time)	15	—	—	ns	

\* These parameters are characterized but not tested.

† Data in "Typ" column is at 5V, 25°C unless otherwise stated. These parameters are for design guidance only and are not tested.



# PIC16C63A/65B/73B/74B

**TABLE 14-16: A/D CONVERTER CHARACTERISTICS:**

**PIC16C73B/74B-04 (COMMERCIAL, INDUSTRIAL, EXTENDED)**  
**PIC16C73B/74B-20 (COMMERCIAL, INDUSTRIAL, EXTENDED)**  
**PIC16LC73B/74B-04 (COMMERCIAL, INDUSTRIAL)**

Param No.	Sym	Characteristic	Min	Typ†	Max	Units	Conditions	
A01	NR	Resolution	—	—	8-bits	bit	VREF = VDD = 5.12V, VSS ≤ VAIN ≤ VREF	
A02	EABS	Total Absolute error	—	—	< ± 1	LSb	VREF = VDD = 5.12V, VSS ≤ VAIN ≤ VREF	
A03	EIL	Integral linearity error	—	—	< ± 1	LSb	VREF = VDD = 5.12V, VSS ≤ VAIN ≤ VREF	
A04	EDL	Differential linearity error	—	—	< ± 1	LSb	VREF = VDD = 5.12V, VSS ≤ VAIN ≤ VREF	
A05	EFS	Full scale error	—	—	< ± 1	LSb	VREF = VDD = 5.12V, VSS ≤ VAIN ≤ VREF	
A06	EOFF	Offset error	—	—	< ± 1	LSb	VREF = VDD = 5.12V, VSS ≤ VAIN ≤ VREF	
A10	—	Monotonicity	—	guaranteed	—	—	VSS ≤ VAIN ≤ VREF	
A20	VREF	Reference voltage	2.5V	—	VDD + 0.3	V		
A25	VAIN	Analog input voltage	VSS - 0.3	—	VREF + 0.3	V		
A30	ZAIN	Recommended impedance of analog voltage source	—	—	10.0	kΩ		
A40	IAD	A/D conversion current (VDD)	Standard	—	180	—	μA	Average current consumption when A/D is on. (Note 1)
			Extended (LC)	—	90	—	μA	
A50	IREF	VREF input current (Note 2)	10	—	1000	—	μA	During VAIN acquisition. Based on differential of VHOLD to VAIN to charge CHOLD, see Section 10.1.
			—	—	10	—	μA	During A/D Conversion cycle

\* These parameters are characterized but not tested.

† Data in "Typ" column is at 5V, 25°C unless otherwise stated. These parameters are for design guidance only and are not tested.

Note1: When A/D is off, it will not consume any current other than minor leakage current.

The power-down current spec includes any such leakage from the A/D module.

2: VREF current is from RA3 pin or VDD pin, whichever is selected as reference input.

# PIC16C63A/65B/73B/74B

**FIGURE 14-17: A/D CONVERSION TIMING**

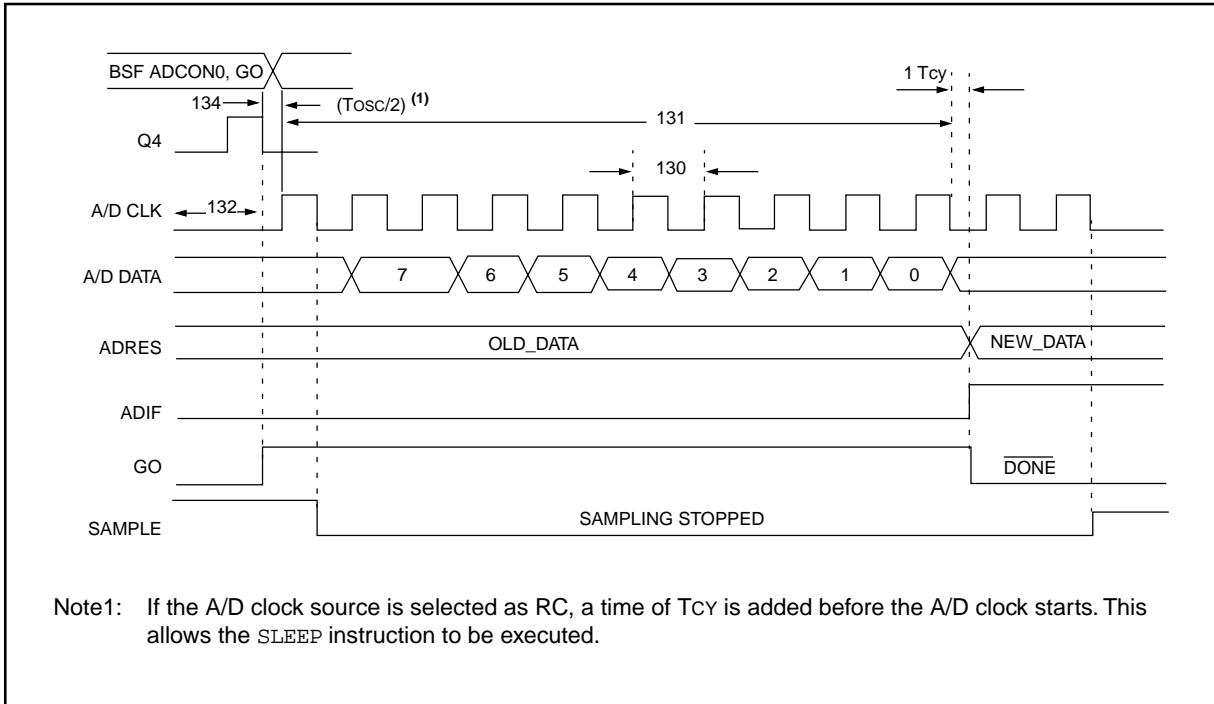

**TABLE 14-17: A/D CONVERSION REQUIREMENTS**

Param No.	Sym	Characteristic		Min	Typ†	Max	Units	Conditions
130	TAD	A/D clock period	Standard	1.6	—	—	μs	TOSC based, VREF ≥ 3.0V
			Extended (LC)	2.0	—	—	μs	TOSC based, VREF full range
			Standard	2.0	4.0	6.0	μs	A/D RC Mode
			Extended (LC)	3.0	6.0	9.0	μs	A/D RC Mode
131	TCNV	Conversion time (not including S/H time) (Note 1)		11	—	11	TAD	
132	TACQ	Acquisition time		Note 2	20	—	μs	The minimum time is the amplifier settling time. This may be used if the "new" input voltage has not changed by more than 1 LSB (i.e., 20.0 mV @ 5.12V) from the last sampled voltage (as stated on CHOLD).
				5*	—	—	μs	
134	TGO	Q4 to A/D clock start		—	Tosc/2 §	—	—	If the A/D clock source is selected as RC, a time of $T_{CY}$ is added before the A/D clock starts. This allows the <b>SLEEP</b> instruction to be executed.
135	TSWC	Switching from convert → sample time		1.5 §	—	—	TAD	

\* These parameters are characterized but not tested.

† Data in "Typ" column is at 5V, 25°C unless otherwise stated. These parameters are for design guidance only and are not tested.

§ This specification ensured by design.

Note1: ADRES register may be read on the following  $T_{CY}$  cycle.

2: See Section 10.1 for min conditions.

## 15.0 DC AND AC CHARACTERISTICS GRAPHS AND TABLES

Graphs and Tables not available at this time.

# PIC16C63A/65B/73B/74B

---

NOTES:

# PIC16C63A/65B/73B/74B

## 16.0 PACKAGING INFORMATION

### 16.1 Package Marking Information

#### 28-Lead PDIP (Skinny DIP)



#### Example



#### 28-Lead CERDIP Windowed

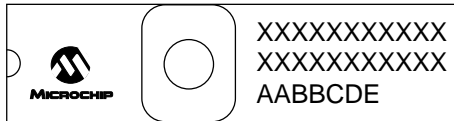

#### Example

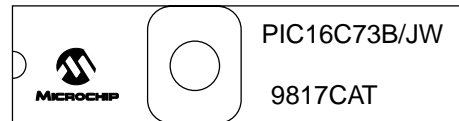

#### 28-Lead SOIC

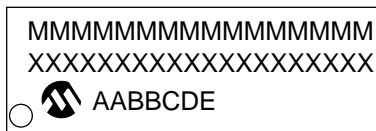

#### Example

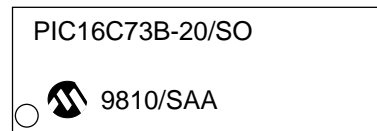

#### 28-Lead SSOP

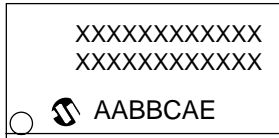

#### Example

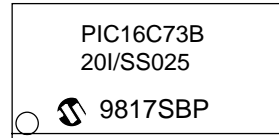

Legend: XX...X	Microchip part number & customer specific information*
AA	Year code (last two digits of calendar year)
BB	Week code (week of January 1 is week '01')
C	Facility code of the plant at which wafer is manufactured C = Chandler, Arizona, U.S.A., S = Tempe, Arizona, U.S.A. - 6" H = Tempe, Arizona, U.S.A. - 8"
D	Mask revision number
E	Assembly code of the plant or country of origin in which part was assembled

**Note:** In the event the full Microchip part number cannot be marked on one line, it will be carried over to the next line, thus limiting the number of available characters for customer specific information.

\* Standard OTP marking consists of Microchip part number, year code, week code, facility code, mask rev# and assembly code. For OTP marking beyond this, certain price adders apply. Please check with your Microchip Sales Office. For QTP devices, any special marking adders are included in QTP price.

# PIC16C63A/65B/73B/74B

## Package Marking Information (Cont'd)

40-Lead PDIP



Example



40-Lead CERDIP Windowed

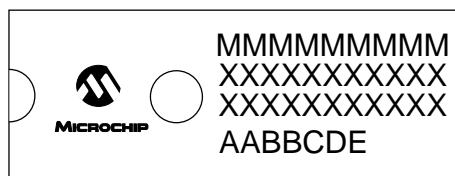

Example

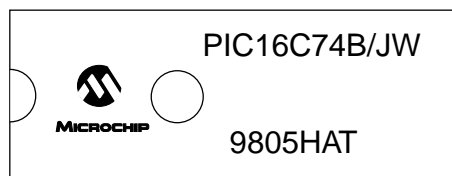

Legend: XX...X	Microchip part number & customer specific information*
AA	Year code (last two digits of calendar year)
BB	Week code (week of January 1 is week '01')
C	Facility code of the plant at which wafer is manufactured
	C = Chandler, Arizona, U.S.A.,
	S = Tempe, Arizona, U.S.A. - 6"
	H = Tempe, Arizona, U.S.A. - 8"
D	Mask revision number
E	Assembly code of the plant or country of origin in which part was assembled

**Note:** In the event the full Microchip part number cannot be marked on one line, it will be carried over to the next line, thus limiting the number of available characters for customer specific information.

\* Standard OTP marking consists of Microchip part number, year code, week code, facility code, mask rev# and assembly code. For OTP marking beyond this, certain price adders apply. Please check with your Microchip Sales Office. For QTP devices, any special marking adders are included in QTP price.

# PIC16C63A/65B/73B/74B

## Package Marking Information (Cont'd)

### 44-Lead TQFP



### Example

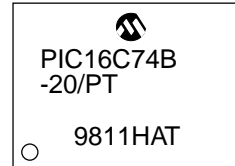

### 44-Lead MQFP

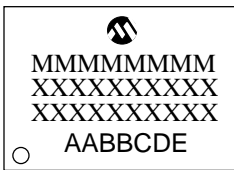

### Example



### 44-Lead PLCC

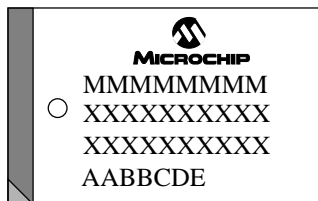

### Example

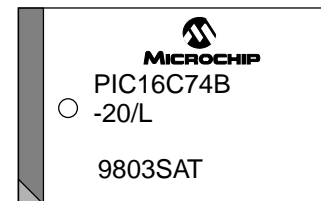

Legend: XX...X	Microchip part number & customer specific information*
AA	Year code (last two digits of calendar year)
BB	Week code (week of January 1 is week '01')
C	Facility code of the plant at which wafer is manufactured
	C = Chandler, Arizona, U.S.A.,
	S = Tempe, Arizona, U.S.A. - 6"
	H = Tempe, Arizona, U.S.A. - 8"
D	Mask revision number
E	Assembly code of the plant or country of origin in which part was assembled

**Note:** In the event the full Microchip part number cannot be marked on one line, it will be carried over to the next line, thus limiting the number of available characters for customer specific information.

\* Standard OTP marking consists of Microchip part number, year code, week code, facility code, mask rev# and assembly code. For OTP marking beyond this, certain price adders apply. Please check with your Microchip Sales Office. For QTP devices, any special marking adders are included in QTP price.

# PIC16C63A/65B/73B/74B

## 16.2 K04-070 28-Lead Skinny Plastic Dual In-line (SP) – 300 mil

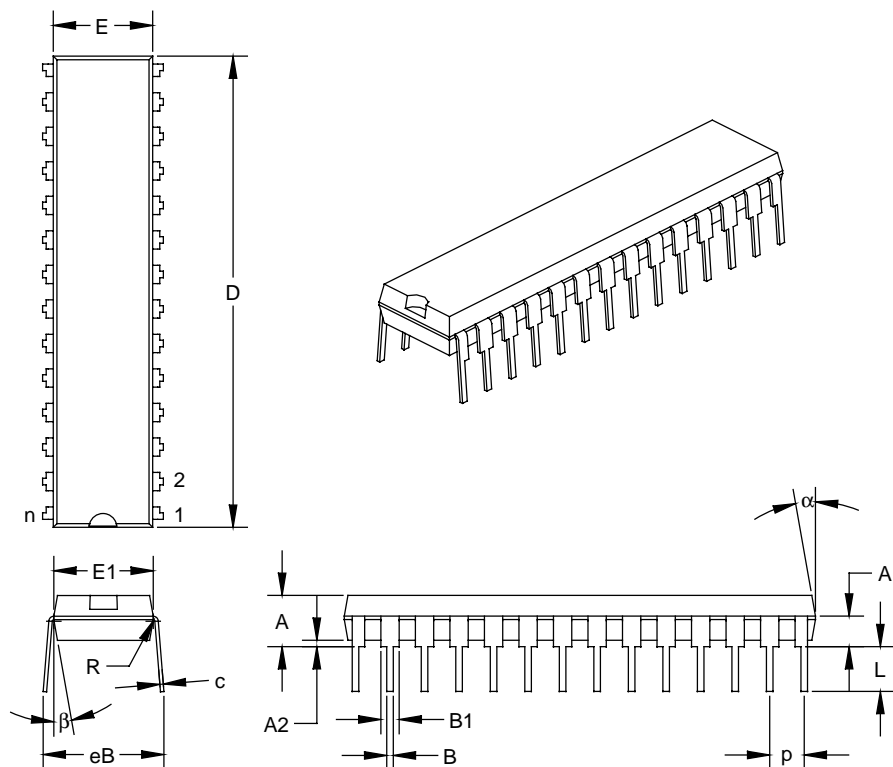

Units		INCHES*			MILLIMETERS		
		MIN	NOM	MAX	MIN	NOM	MAX
Dimension Limits							
PCB Row Spacing			0.300			7.62	
Number of Pins	n		28			28	
Pitch	p		0.100			2.54	
Lower Lead Width	B	0.016	0.019	0.022	0.41	0.48	0.56
Upper Lead Width	B1 <sup>†</sup>	0.040	0.053	0.065	1.02	1.33	1.65
Shoulder Radius	R	0.000	0.005	0.010	0.00	0.13	0.25
Lead Thickness	c	0.008	0.010	0.012	0.20	0.25	0.30
Top to Seating Plane	A	0.140	0.150	0.160	3.56	3.81	4.06
Top of Lead to Seating Plane	A1	0.070	0.090	0.110	1.78	2.29	2.79
Base to Seating Plane	A2	0.015	0.020	0.025	0.38	0.51	0.64
Tip to Seating Plane	L	0.125	0.130	0.135	3.18	3.30	3.43
Package Length	D <sup>‡</sup>	1.345	1.365	1.385	34.16	34.67	35.18
Molded Package Width	E <sup>‡</sup>	0.280	0.288	0.295	7.11	7.30	7.49
Radius to Radius Width	E1	0.270	0.283	0.295	6.86	7.18	7.49
Overall Row Spacing	eB	0.320	0.350	0.380	8.13	8.89	9.65
Mold Draft Angle Top	alpha	5	10	15	5	10	15
Mold Draft Angle Bottom	beta	5	10	15	5	10	15

\* Controlling Parameter.

<sup>†</sup> Dimension "B1" does not include dam-bar protrusions. Dam-bar protrusions shall not exceed 0.003" (0.076 mm) per side or 0.006" (0.152 mm) more than dimension "B1."

<sup>‡</sup> Dimensions "D" and "E" do not include mold flash or protrusions. Mold flash or protrusions shall not exceed 0.010" (0.254 mm) per side or 0.020" (0.508 mm) more than dimensions "D" or "E."



# PIC16C63A/65B/73B/74B

## 16.3 K04-080 28-Lead Ceramic Dual In-line with Window (JW) – 300 mil

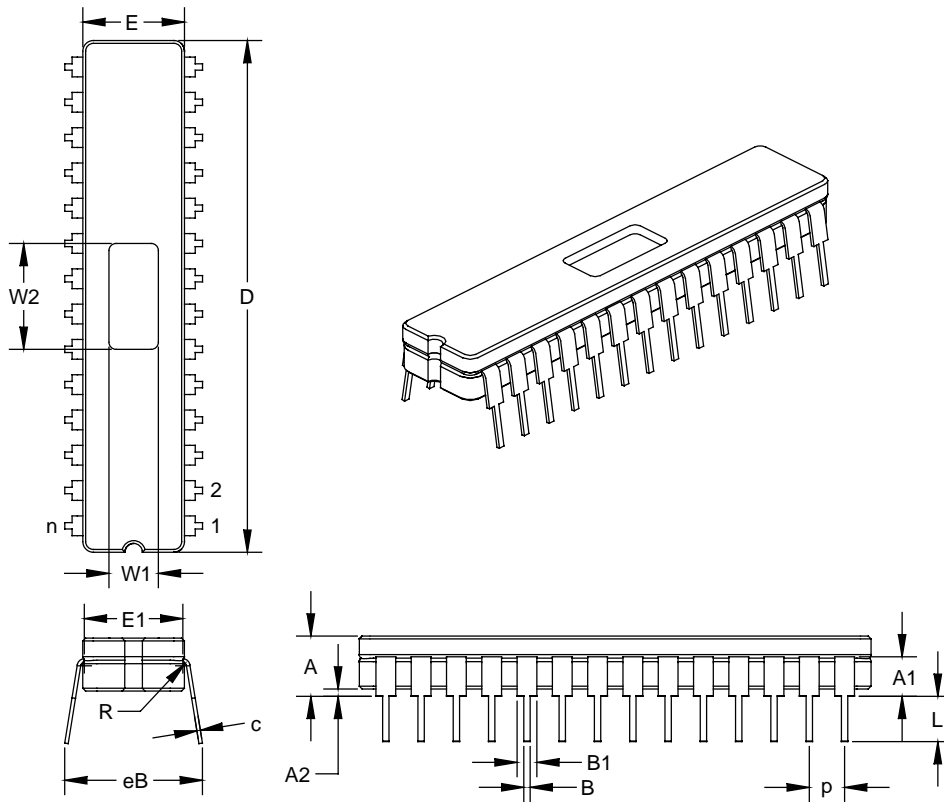

Units		INCHES*			MILLIMETERS		
		MIN	NOM	MAX	MIN	NOM	MAX
Dimension Limits			0.300			7.62	
PCB Row Spacing							
Number of Pins	n		28			28	
Pitch	p	0.098	0.100	0.102	2.49	2.54	2.59
Lower Lead Width	B	0.016	0.019	0.021	0.41	0.47	0.53
Upper Lead Width	B1	0.050	0.058	0.065	1.27	1.46	1.65
Shoulder Radius	R	0.010	0.013	0.015	0.25	0.32	0.38
Lead Thickness	c	0.008	0.010	0.012	0.20	0.25	0.30
Top to Seating Plane	A	0.170	0.183	0.195	4.32	4.64	4.95
Top of Lead to Seating Plane	A1	0.107	0.125	0.143	2.72	3.18	3.63
Base to Seating Plane	A2	0.015	0.023	0.030	0.00	0.57	0.76
Tip to Seating Plane	L	0.135	0.140	0.145	3.43	3.56	3.68
Package Length	D	1.430	1.458	1.485	36.32	37.02	37.72
Package Width	E	0.285	0.290	0.295	7.24	7.37	7.49
Radius to Radius Width	E1	0.255	0.270	0.285	6.48	6.86	7.24
Overall Row Spacing	eB	0.345	0.385	0.425	8.76	9.78	10.80
Window Width	W1	0.130	0.140	0.150	0.13	0.14	0.15
Window Length	W2	0.290	0.300	0.310	0.29	0.3	0.31

\* Controlling Parameter.

# PIC16C63A/65B/73B/74B

## 16.4 K04-052 28-Lead Plastic Small Outline (SO) – Wide, 300 mil

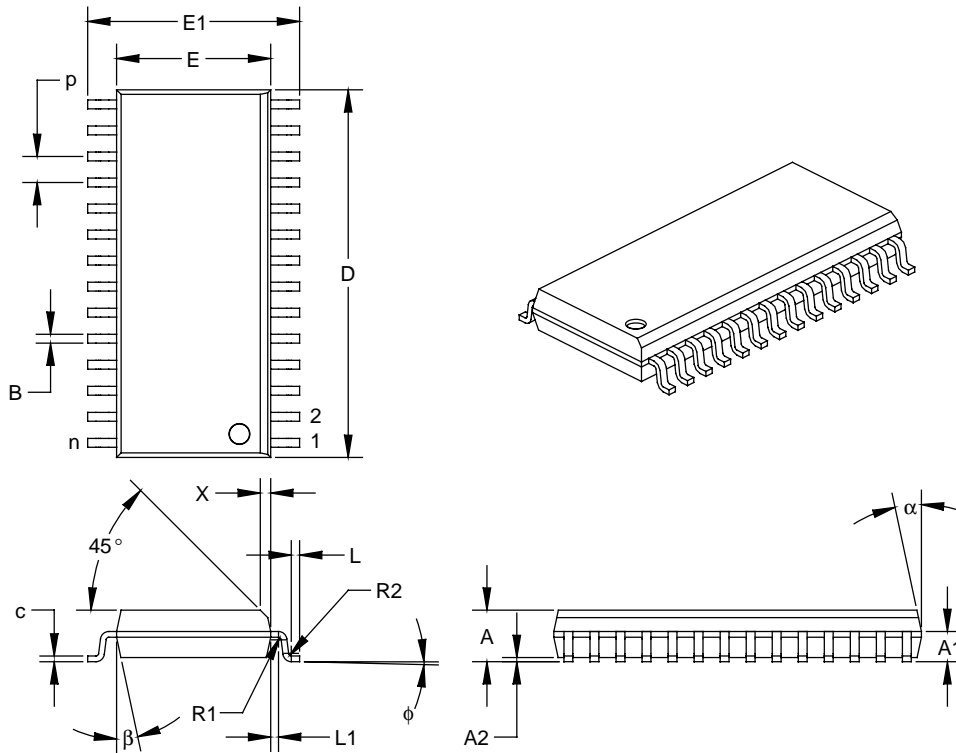

Units		INCHES*			MILLIMETERS		
		MIN	NOM	MAX	MIN	NOM	MAX
Dimension Limits							
Pitch	p		0.050			1.27	
Number of Pins	n		28			28	
Overall Pack. Height	A	0.093	0.099	0.104	2.36	2.50	2.64
Shoulder Height	A1	0.048	0.058	0.068	1.22	1.47	1.73
Standoff	A2	0.004	0.008	0.011	0.10	0.19	0.28
Molded Package Length	D <sup>‡</sup>	0.700	0.706	0.712	17.78	17.93	18.08
Molded Package Width	E <sup>‡</sup>	0.292	0.296	0.299	7.42	7.51	7.59
Outside Dimension	E1	0.394	0.407	0.419	10.01	10.33	10.64
Chamfer Distance	X	0.010	0.020	0.029	0.25	0.50	0.74
Shoulder Radius	R1	0.005	0.005	0.010	0.13	0.13	0.25
Gull Wing Radius	R2	0.005	0.005	0.010	0.13	0.13	0.25
Foot Length	L	0.011	0.016	0.021	0.28	0.41	0.53
Foot Angle	phi	0	4	8	0	4	8
Radius Centerline	L1	0.010	0.015	0.020	0.25	0.38	0.51
Lead Thickness	c	0.009	0.011	0.012	0.23	0.27	0.30
Lower Lead Width	B <sup>†</sup>	0.014	0.017	0.019	0.36	0.42	0.48
Mold Draft Angle Top	alpha	0	12	15	0	12	15
Mold Draft Angle Bottom	beta	0	12	15	0	12	15

\* Controlling Parameter.

† Dimension "B" does not include dam-bar protrusions. Dam-bar protrusions shall not exceed 0.003" (0.076 mm) per side or 0.006" (0.152 mm) more than dimension "B."

‡ Dimensions "D" and "E" do not include mold flash or protrusions. Mold flash or protrusions shall not exceed 0.010" (0.254 mm) per side or 0.020" (0.508 mm) more than dimensions "D" or "E."

# PIC16C63A/65B/73B/74B

## 16.5 K04-073 28-Lead Plastic Shrink Small Outline (SS) – 5.30 mm

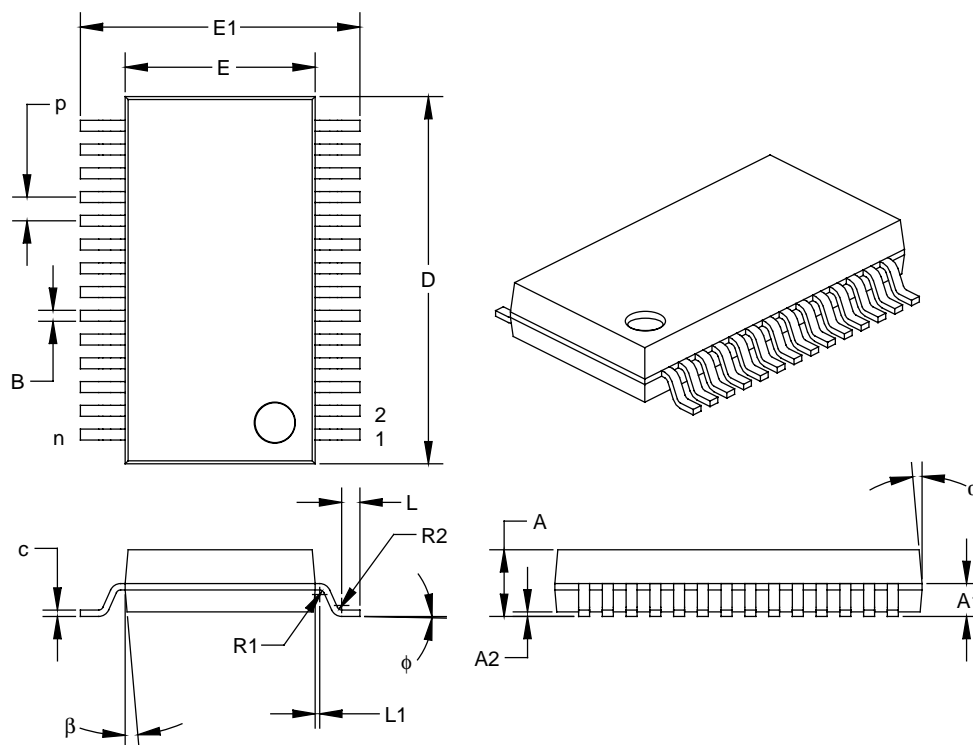

Units		INCHES			MILLIMETERS*		
		MIN	NOM	MAX	MIN	NOM	MAX
Dimension Limits							
Pitch	p		0.026			0.65	
Number of Pins	n		28			28	
Overall Pack. Height	A	0.068	0.073	0.078	1.73	1.86	1.99
Shoulder Height	A1	0.026	0.036	0.046	0.66	0.91	1.17
Standoff	A2	0.002	0.005	0.008	0.05	0.13	0.21
Molded Package Length	D <sup>‡</sup>	0.396	0.402	0.407	10.07	10.20	10.33
Molded Package Width	E <sup>‡</sup>	0.205	0.208	0.212	5.20	5.29	5.38
Outside Dimension	E1	0.301	0.306	0.311	7.65	7.78	7.90
Shoulder Radius	R1	0.005	0.005	0.010	0.13	0.13	0.25
Gull Wing Radius	R2	0.005	0.005	0.010	0.13	0.13	0.25
Foot Length	L	0.015	0.020	0.025	0.38	0.51	0.64
Foot Angle	φ	0	4	8	0	4	8
Radius Centerline	L1	0.000	0.005	0.010	0.00	0.13	0.25
Lead Thickness	c	0.005	0.007	0.009	0.13	0.18	0.22
Lower Lead Width	B <sup>†</sup>	0.010	0.012	0.015	0.25	0.32	0.38
Mold Draft Angle Top	α	0	5	10	0	5	10
Mold Draft Angle Bottom	β	0	5	10	0	5	10

\* Controlling Parameter.

† Dimension "B" does not include dam-bar protrusions. Dam-bar protrusions shall not exceed 0.003" (0.076 mm) per side or 0.006" (0.152 mm) more than dimension "B."

‡ Dimensions "D" and "E" do not include mold flash or protrusions. Mold flash or protrusions shall not exceed 0.010" (0.254 mm) per side or 0.020" (0.508 mm) more than dimensions "D" or "E."

# PIC16C63A/65B/73B/74B

## 16.6 K04-016 40-Lead Plastic Dual In-line (P) – 600 mil

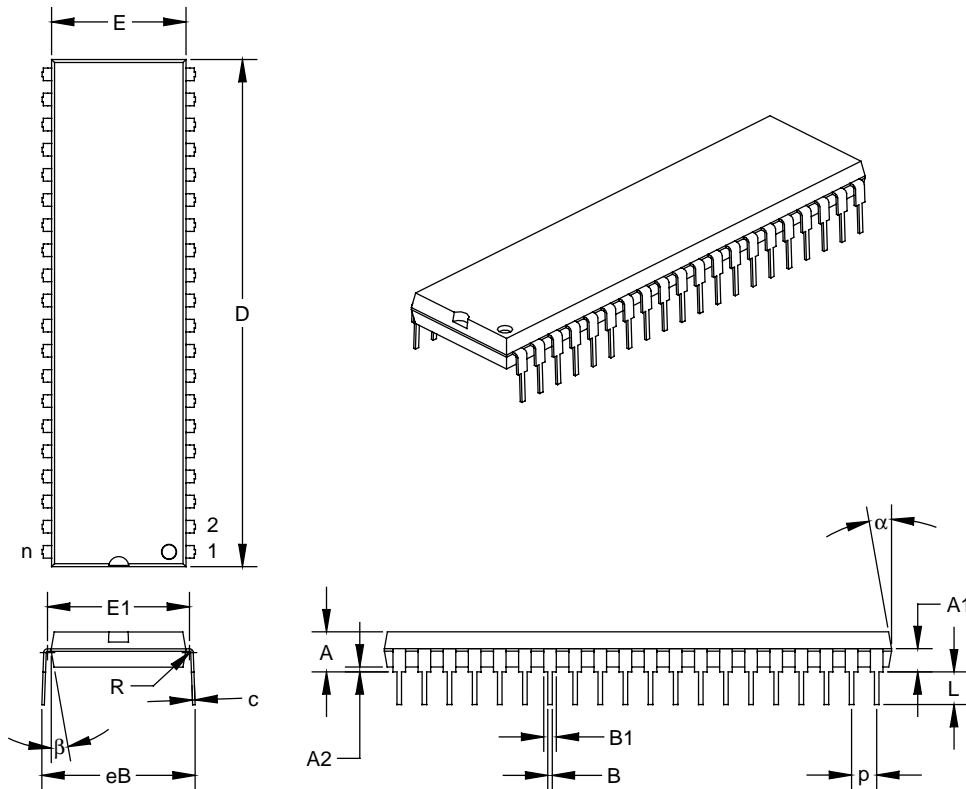

Units		INCHES*			MILLIMETERS		
		MIN	NOM	MAX	MIN	NOM	MAX
Dimension Limits			0.600			15.24	
PCB Row Spacing			0.600			15.24	
Number of Pins	n		40			40	
Pitch	p		0.100			2.54	
Lower Lead Width	B	0.016	0.018	0.020	0.41	0.46	0.51
Upper Lead Width	B1†	0.045	0.050	0.055	1.14	1.27	1.40
Shoulder Radius	R	0.000	0.005	0.010	0.00	0.13	0.25
Lead Thickness	c	0.009	0.010	0.011	0.23	0.25	0.28
Top to Seating Plane	A	0.110	0.160	0.160	2.79	4.06	4.06
Top of Lead to Seating Plane	A1	0.073	0.093	0.113	1.85	2.36	2.87
Base to Seating Plane	A2	0.020	0.020	0.040	0.51	0.51	1.02
Tip to Seating Plane	L	0.125	0.130	0.135	3.18	3.30	3.43
Package Length	D‡	2.013	2.018	2.023	51.13	51.26	51.38
Molded Package Width	E‡	0.530	0.535	0.540	13.46	13.59	13.72
Radius to Radius Width	E1	0.545	0.565	0.585	13.84	14.35	14.86
Overall Row Spacing	eB	0.630	0.610	0.670	16.00	15.49	17.02
Mold Draft Angle Top	α	5	10	15	5	10	15
Mold Draft Angle Bottom	β	5	10	15	5	10	15

\* Controlling Parameter.

† Dimension "B1" does not include dam-bar protrusions. Dam-bar protrusions shall not exceed 0.003" (0.076 mm) per side or 0.006" (0.152 mm) more than dimension "B1."

‡ Dimensions "D" and "E" do not include mold flash or protrusions. Mold flash or protrusions shall not exceed 0.010" (0.254 mm) per side or 0.020" (0.508 mm) more than dimensions "D" or "E."

# PIC16C63A/65B/73B/74B

## 16.7 K04-014 40-Lead Ceramic Dual In-line with Window (JW) – 600 mil

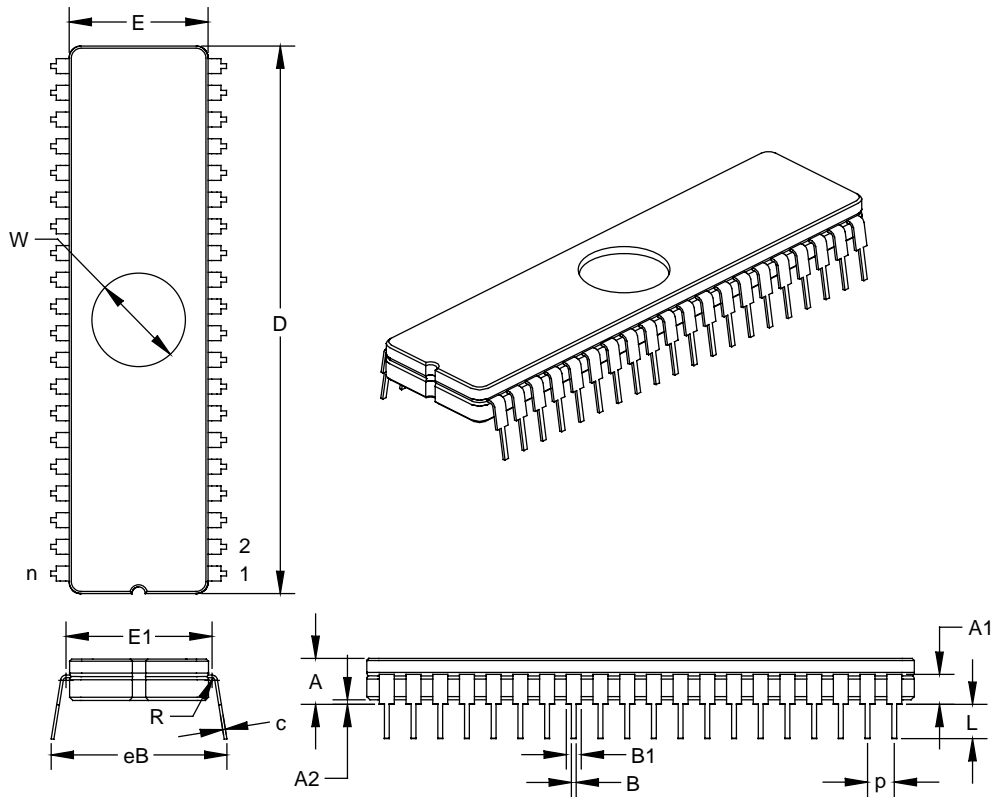

Units		INCHES*			MILLIMETERS		
		MIN	NOM	MAX	MIN	NOM	MAX
Dimension Limits			0.600			15.24	
PCB Row Spacing							
Number of Pins	n		40			40	
Pitch	p	0.098	0.100	0.102	2.49	2.54	2.59
Lower Lead Width	B	0.016	0.020	0.023	0.41	0.50	0.58
Upper Lead Width	B1	0.050	0.053	0.055	1.27	1.33	1.40
Shoulder Radius	R	0.000	0.005	0.010	0.00	0.13	0.25
Lead Thickness	c	0.008	0.011	0.014	0.20	0.28	0.36
Top to Seating Plane	A	0.190	0.205	0.220	4.83	5.21	5.59
Top of Lead to Seating Plane	A1	0.117	0.135	0.153	2.97	3.43	3.89
Base to Seating Plane	A2	0.030	0.045	0.060	0.00	1.14	1.52
Tip to Seating Plane	L	0.135	0.140	0.145	3.43	3.56	3.68
Package Length	D	2.040	2.050	2.060	51.82	52.07	52.32
Package Width	E	0.514	0.520	0.526	13.06	13.21	13.36
Radius to Radius Width	E1	0.560	0.580	0.600	14.22	14.73	15.24
Overall Row Spacing	eB	0.610	0.660	0.710	15.49	16.76	18.03
Window Diameter	W	0.340	0.350	0.360	8.64	8.89	9.14

\* Controlling Parameter.

# PIC16C63A/65B/73B/74B

## 16.8 K04-076 44-Lead Plastic Thin Quad Flatpack (PT) 10x10x1 mm Body, 1.0/0.1 mm Lead Form

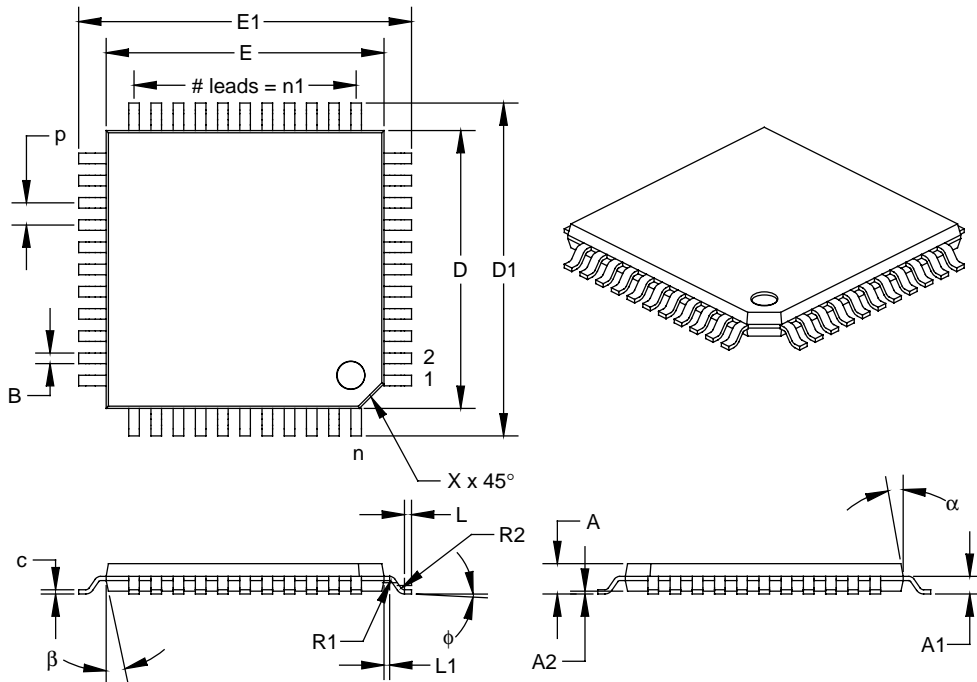

Units		INCHES			MILLIMETERS*		
		MIN	NOM	MAX	MIN	NOM	MAX
Dimension Limits							
Pitch	p		0.031			0.80	
Number of Pins	n		44			44	
Pins along Width	n1		11			11	
Overall Pack. Height	A	0.039	0.043	0.047	1.00	1.10	1.20
Shoulder Height	A1	0.015	0.025	0.035	0.38	0.64	0.89
Standoff	A2	0.002	0.004	0.006	0.05	0.10	0.15
Shoulder Radius	R1	0.003	0.003	0.010	0.08	0.08	0.25
Gull Wing Radius	R2	0.003	0.006	0.008	0.08	0.14	0.20
Foot Length	L	0.005	0.010	0.015	0.13	0.25	0.38
Foot Angle	φ	0	3.5	7	0	3.5	7
Radius Centerline	L1	0.003	0.008	0.013	0.08	0.20	0.33
Lead Thickness	c	0.004	0.006	0.008	0.09	0.15	0.20
Lower Lead Width	B <sup>†</sup>	0.012	0.015	0.018	0.30	0.38	0.45
Outside Tip Length	D1	0.463	0.472	0.482	11.75	12.00	12.25
Outside Tip Width	E1	0.463	0.472	0.482	11.75	12.00	12.25
Molded Pack. Length	D <sup>‡</sup>	0.390	0.394	0.398	9.90	10.00	10.10
Molded Pack. Width	E <sup>‡</sup>	0.390	0.394	0.398	9.90	10.00	10.10
Pin 1 Corner Chamfer	X	0.025	0.035	0.045	0.64	0.89	1.14
Mold Draft Angle Top	α	5	10	15	5	10	15
Mold Draft Angle Bottom	β	5	12	15	5	12	15

\* Controlling Parameter.

† Dimension "B" does not include dam-bar protrusions. Dam-bar protrusions shall not exceed 0.003" (0.076 mm) per side or 0.006" (0.152 mm) more than dimension "B."

‡ Dimensions "D" and "E" do not include mold flash or protrusions. Mold flash or protrusions shall not exceed 0.010" (0.254 mm) per side or 0.020" (0.508 mm) more than dimensions "D" or "E."

JEDEC equivalent: MS-026 ACB

# PIC16C63A/65B/73B/74B

## 16.9 K04-071 44-Lead Plastic Quad Flatpack (PQ) 10x10x2 mm Body, 1.6/0.15 mm Lead Form

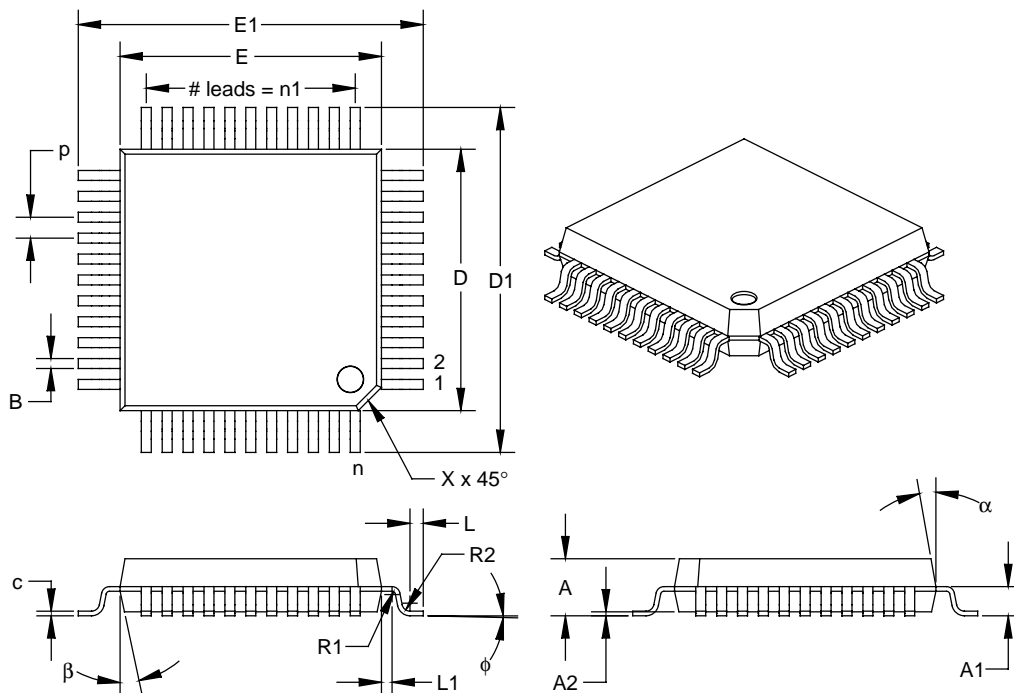

Units		INCHES			MILLIMETERS*		
		MIN	NOM	MAX	MIN	NOM	MAX
Dimension Limits							
Pitch	p		0.031			0.80	
Number of Pins	n		44			44	
Pins along Width	n1		11			11	
Overall Pack. Height	A	0.079	0.086	0.093	2.00	2.18	2.35
Shoulder Height	A1	0.032	0.044	0.056	0.81	1.11	1.41
Standoff	A2	0.002	0.006	0.010	0.05	0.15	0.25
Shoulder Radius	R1	0.005	0.005	0.010	0.13	0.13	0.25
Gull Wing Radius	R2	0.005	0.012	0.015	0.13	0.30	0.38
Foot Length	L	0.015	0.020	0.025	0.38	0.51	0.64
Foot Angle	$\phi$	0	3.5	7	0	3.5	7
Radius Centerline	L1	0.011	0.016	0.021	0.28	0.41	0.53
Lead Thickness	c	0.005	0.007	0.009	0.13	0.18	0.23
Lower Lead Width	B <sup>†</sup>	0.012	0.015	0.018	0.30	0.37	0.45
Outside Tip Length	D1	0.510	0.520	0.530	12.95	13.20	13.45
Outside Tip Width	E1	0.510	0.520	0.530	12.95	13.20	13.45
Molded Pack. Length	D <sup>‡</sup>	0.390	0.394	0.398	9.90	10.00	10.10
Molded Pack. Width	E <sup>‡</sup>	0.390	0.394	0.398	9.90	10.00	10.10
Pin 1 Corner Chamfer	X	0.025	0.035	0.045	0.635	0.89	1.143
Mold Draft Angle Top	$\alpha$	5	10	15	5	10	15
Mold Draft Angle Bottom	$\beta$	5	12	15	5	12	15

\* Controlling Parameter.

<sup>†</sup> Dimension "B" does not include dam-bar protrusions. Dam-bar protrusions shall not exceed 0.003" (0.076 mm) per side or 0.006" (0.152 mm) more than dimension "B."

<sup>‡</sup> Dimensions "D" and "E" do not include mold flash or protrusions. Mold flash or protrusions shall not exceed 0.010" (0.254 mm) per side or 0.020" (0.508 mm) more than dimensions "D" or "E."

JEDEC equivalent: MS-022 AB

# PIC16C63A/65B/73B/74B

## 16.10 K04-048 44-Lead Plastic Leaded Chip Carrier (L) – Square

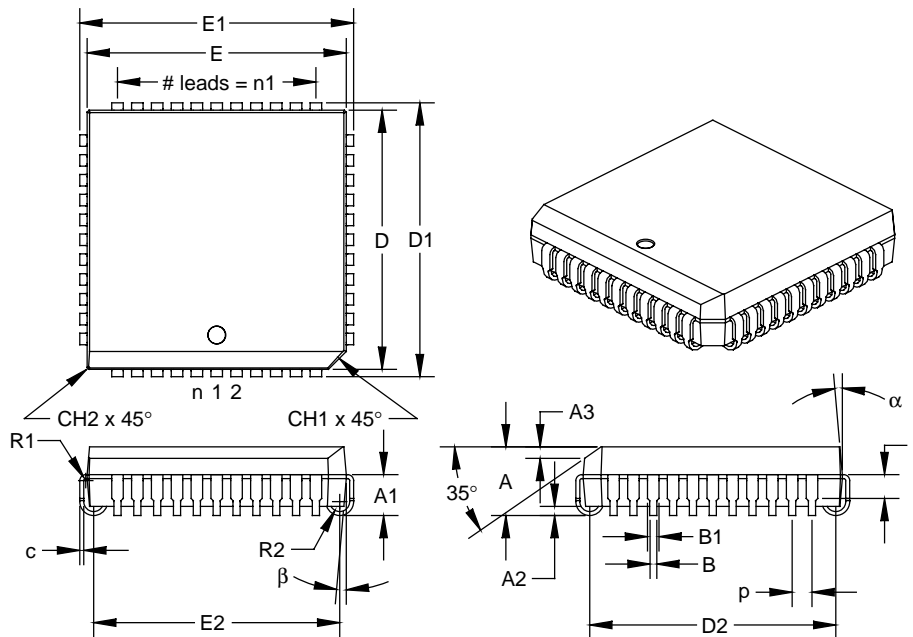

Units		INCHES*			MILLIMETERS		
Dimension	Limits	MIN	NOM	MAX	MIN	NOM	MAX
Number of Pins	n		44			44	
Pitch	p		0.050			1.27	
Overall Pack. Height	A	0.165	0.173	0.180	4.19	4.38	4.57
Shoulder Height	A1	0.095	0.103	0.110	2.41	2.60	2.79
Standoff	A2	0.015	0.023	0.030	0.38	0.57	0.76
Side 1 Chamfer Dim.	A3	0.024	0.029	0.034	0.61	0.74	0.86
Corner Chamfer (1)	CH1	0.040	0.045	0.050	1.02	1.14	1.27
Corner Chamfer (other)	CH2	0.000	0.005	0.010	0.00	0.13	0.25
Overall Pack. Width	E1	0.685	0.690	0.695	17.40	17.53	17.65
Overall Pack. Length	D1	0.685	0.690	0.695	17.40	17.53	17.65
Molded Pack. Width	E <sup>‡</sup>	0.650	0.653	0.656	16.51	16.59	16.66
Molded Pack. Length	D <sup>‡</sup>	0.650	0.653	0.656	16.51	16.59	16.66
Footprint Width	E2	0.610	0.620	0.630	15.49	15.75	16.00
Footprint Length	D2	0.610	0.620	0.630	15.49	15.75	16.00
Pins along Width	n1		11			11	
Lead Thickness	c	0.008	0.010	0.012	0.20	0.25	0.30
Upper Lead Width	B1 <sup>†</sup>	0.026	0.029	0.032	0.66	0.74	0.81
Lower Lead Width	B	0.015	0.018	0.021	0.38	0.46	0.53
Upper Lead Length	L	0.050	0.058	0.065	1.27	1.46	1.65
Shoulder Inside Radius	R1	0.003	0.005	0.010	0.08	0.13	0.25
J-Bend Inside Radius	R2	0.015	0.025	0.035	0.38	0.64	0.89
Mold Draft Angle Top	α	0	5	10	0	5	10
Mold Draft Angle Bottom	β	0	5	10	0	5	10

\* Controlling Parameter.

† Dimension "B1" does not include dam-bar protrusions. Dam-bar protrusions shall not exceed 0.003" (0.076 mm) per side or 0.006" (0.152 mm) more than dimension "B1."

‡ Dimensions "D" and "E" do not include mold flash or protrusions. Mold flash or protrusions shall not exceed 0.010" (0.254 mm) per side or 0.020" (0.508 mm) more than dimensions "D" or "E."

JEDEC equivalent: MO-047 AC



# PIC16C63A/65B/73B/74B

## APPENDIX A: REVISION HISTORY

Version	Date	Revision Description
A	7/98	This is a new data sheet. However, the devices described in this data sheet are the upgrades to the devices found in the <i>PIC16C6X Data Sheet</i> , DS30234D, and the <i>PIC16C7X Data Sheet</i> , DS30390E.

## APPENDIX B: DEVICE DIFFERENCES

The differences between the devices in this data sheet are listed in Table B-1.

**TABLE B-1: DEVICE DIFFERENCES**

Difference	PIC16C63A	PIC16C65B	PIC16C73B	PIC16C74B
A/D	no	no	5 channels, 8 bits	8 channels, 8 bits
Parallel Slave Port	no	yes	no	yes
Packages	28-pin PDIP, 28-pin windowed CERDIP, 28-pin SOIC, 28-pin SSOP	40-pin PDIP, 40-pin windowed CERDIP, 44-pin TQFP, 44-pin MQFP, 44-pin PLCC	28-pin PDIP, 28-pin windowed CERDIP, 28-pin SOIC, 28-pin SSOP	40-pin PDIP, 40-pin windowed CERDIP, 44-pin TQFP, 44-pin MQFP, 44-pin PLCC

## APPENDIX C: CONVERSION CONSIDERATIONS

Considerations for converting from previous versions of devices to the ones listed in this data sheet are listed in Table C-1.

**TABLE C-1: CONVERSION CONSIDERATIONS**

Difference	PIC16C63/65A/73A/74A	PIC16C63A/65B/73B/74B
Voltage Range	2.5V - 6.0V	2.5V - 5.5V
SSP module	single mode SPI	4-mode SPI
SSP module	Can only transmit one word in SPI mode of enhanced SSP.	N/A
CCP module	CCP does not reset TMR1 when in special event trigger mode.	N/A
USART module	USART receiver errata in BRGH=1 mode.	N/A
Timer1 module	Writing to TMR1L register can cause overflow in TMR1H register.	N/A

# PIC16C63A/65B/73B/74B

---

## APPENDIX D: MIGRATION FROM BASELINE TO MIDRANGE DEVICES

This section discusses how to migrate from a baseline device (i.e., PIC16C5X) to a midrange device (i.e., PIC16CXXX).

The following are the list of modifications over the PIC16C5X microcontroller family:

1. Instruction word length is increased to 14-bits. This allows larger page sizes both in program memory (2K now as opposed to 512 before) and register file (128 bytes now versus 32 bytes before).
2. A PC high latch register (PCLATH) is added to handle program memory paging. Bits PA2, PA1, PA0 are removed from STATUS register.
3. Data memory paging is redefined slightly. STATUS register is modified.
4. Four new instructions have been added: RETURN, RETFIE, ADDLW, and SUBLW. Two instructions TRIS and OPTION are being phased out although they are kept for compatibility with PIC16C5X.
5. OPTION and TRIS registers are made addressable.
6. Interrupt capability is added. Interrupt vector is at 0004h.
7. Stack size is increased to 8 deep.
8. Reset vector is changed to 0000h.
9. Reset of all registers is revisited. Five different reset (and wake-up) types are recognized. Registers are reset differently.
10. Wake up from SLEEP through interrupt is added.
11. Two separate timers, Oscillator Start-up Timer (OST) and Power-up Timer (PWRT) are included for more reliable power-up. These timers are invoked selectively to avoid unnecessary delays on power-up and wake-up.
12. PORTB has weak pull-ups and interrupt on change feature.
13. T0CKI pin is also a port pin (RA4) now.
14. FSR is made a full eight bit register.
15. "In-circuit serial programming" is made possible. The user can program PIC16CXX devices using only five pins: VDD, VSS, MCLR/VPP, RB6 (clock) and RB7 (data in/out).
16. PCON status register is added with a Power-on Reset status bit ( $\overline{POR}$ ).
17. Code protection scheme is enhanced such that portions of the program memory can be protected, while the remainder is unprotected.
18. Brown-out protection circuitry has been added. Controlled by configuration word bit BODEN. Brown-out reset ensures the device is placed in a reset condition if VDD dips below a fixed set-point.

To convert code written for PIC16C5X to PIC16CXXX, the user should take the following steps:

1. Remove any program memory page select operations (PA2, PA1, PA0 bits) for CALL, GOTO.
2. Revisit any computed jump operations (write to PC or add to PC, etc.) to make sure page bits are set properly under the new scheme.
3. Eliminate any data memory page switching. Redefine data variables to reallocate them.
4. Verify all writes to STATUS, OPTION, and FSR registers since these have changed.
5. Change reset vector to 0000h.

# PIC16C63A/65B/73B/74B

## APPENDIX E: BIT/REGISTER CROSS-REFERENCE LIST

ADCS1:ADCS0 .....	ADCON0<7:6>	T0IE .....	INTCON<5>
ADIE .....	PIE1<6>	T0IF .....	INTCON<2>
ADIF .....	PIR1<6>	T0SE .....	OPTION_REG<4>
ADON .....	ADCON0<0>	T1CKPS1:T1CKPS0 .....	T1CON<5:4>
BF .....	SSPSTAT<0>	T1OSCEN .....	T1CON<3>
BOR .....	PCON<0>	T1SYNC .....	T1CON<2>
BRGH .....	TXSTA<2>	T2CKPS1:T2CKPS0 .....	T2CON<1:0>
C .....	STATUS<0>	TMR1CS .....	T1CON<1>
CCP1IE .....	PIE1<2>	TMR1IE .....	PIE1<0>
CCP1IF .....	PIR1<2>	TMR1IF .....	PIR1<0>
CCP1M3:CCP1M0 .....	CCP1CON<3:0>	TMR1ON .....	T1CON<0>
CCP1X:CCP1Y .....	CCP1CON<5:4>	TMR2IE .....	PIE1<1>
CCP2IE .....	PIE2<0>	TMR2IF .....	PIR1<1>
CCP2IF .....	PIR2<0>	TMR2ON .....	T2CON<2>
CCP2M3:CCP2M0 .....	CCP2CON<3:0>	TÖ .....	STATUS<4>
CCP2X:CCP2Y .....	CCP2CON<5:4>	TOUTPS3:TOUTPS0 .....	T2CON<6:3>
CHS2:CHS0 .....	ADCON0<5:3>	TRMT .....	TXSTA<1>
CKE .....	SSPSTAT<6>	TX9 .....	TXSTA<6>
CKP .....	SSPCON<4>	TX9D .....	TXSTA<0>
CREN .....	RCSTA<4>	TXEN .....	TXSTA<5>
CSRC .....	TXSTA<7>	TXIE .....	PIE1<4>
D/Ā .....	SSPSTAT<5>	TXIF .....	PIR1<4>
DC .....	STATUS<1>	UA .....	SSPSTAT<1>
FERR .....	RCSTA<2>	WCOL .....	SSPCON<7>
GIE .....	INTCON<7>	Z .....	STATUS<2>
GO/DONE .....	ADCON0<2>		
IBF .....	TRISE<7>		
IBOV .....	TRISE<5>		
INTE .....	INTCON<4>		
INTEDG .....	OPTION_REG<6>		
INTF .....	INTCON<1>		
IRP .....	STATUS<7>		
OBF .....	TRISE<6>		
OERR .....	RCSTA<1>		
P .....	SSPSTAT<4>		
PCFG2:PCFG0 .....	ADCON1<2:0>		
PD .....	STATUS<3>		
PEIE .....	INTCON<6>		
POR .....	PCON<1>		
PS2:PS0 .....	OPTION_REG<2:0>		
PSA .....	OPTION_REG<3>		
PSPIE .....	PIE1<7>		
PSPIF .....	PIR1<7>		
PSPMODE .....	TRISE<4>		
R/W .....	SSPSTAT<2>		
RBIE .....	INTCON<3>		
RBIF .....	INTCON<0>		
RBPU .....	OPTION_REG<7>		
RCIE .....	PIE1<5>		
RCIF .....	PIR1<5>		
RP1:RP0 .....	STATUS<6:5>		
RX9 .....	RCSTA<6>		
RX9D .....	RCSTA<0>		
S .....	SSPSTAT<3>		
SMP .....	SSPSTAT<7>		
SPEN .....	RCSTA<7>		
SREN .....	RCSTA<5>		
SSPEN .....	SSPCON<5>		
SSPIE .....	PIE1<3>		
SSPIF .....	PIR1<3>		
SSPM3:SSPM0 .....	SSPCON<3:0>		
SSPOV .....	SSPCON<6>		
SYNC .....	TXSTA<4>		
T0CS .....	OPTION_REG<5>		

# PIC16C63A/65B/73B/74B

---

NOTES:

# PIC16C63A/65B/73B/74B

## INDEX

### A

A/D	75
A/D Converter Enable (ADIE Bit)	18
A/D Converter Flag (ADIF Bit)	19, 77
A/D Converter Interrupt, Configuring	77
ADCON0 Register	13, 75
ADCON1 Register	14, 75, 76
ADRES Register	13, 75, 77
Analog Port Pins	7, 8, 9, 34, 35
Analog Port Pins, Configuring	79
Block Diagram	77
Block Diagram, Analog Input Model	78
Channel Select (CHS2:CHS0 Bits)	75
Clock Select (ADCS1:ADCS0 Bits)	75
Configuring the Module	77
Conversion Clock (TAD)	79
Conversion Status (GO/DONE Bit)	75, 77
Conversions	80
Converter Characteristics	121
Module On/Off (ADON Bit)	75
Port Configuration Control (PCFG2:PCFG0 Bits)	76
Sampling Requirements	78
Special Event Trigger (CCP)	47, 80
Timing Diagram	122
Absolute Maximum Ratings	101
ADCON0 Register	13, 75
ADCS1:ADCS0 Bits	75
ADON Bit	75
CHS2:CHS0 Bits	75
GO/DONE Bit	75, 77
ADCON1 Register	14, 75, 76
PCFG2:PCFG0 Bits	76
ADRES Register	13, 75, 77
Architecture	
PIC16C63A/PIC16C73B Block Diagram	5
PIC16C65B/PIC16C74B Block Diagram	6
Assembler	
MPASM Assembler	98

### B

Banking, Data Memory	11, 15
Brown-out Reset (BOR)	81, 83, 85, 86, 87
BOR Enable (BODEN Bit)	81
BOR Status (BOR Bit)	22
Timing Diagram	110

### C

Capture (CCP Module)	46
Block Diagram	46
CCP Pin Configuration	46
CCPR1H:CCPR1L Registers	46
Changing Between Capture Prescalers	46
Software Interrupt	46
Timer1 Mode Selection	46
Capture/Compare/PWM (CCP)	45
CCP1	45
CCP1CON Register	13, 45
CCPR1H Register	13, 45
CCPR1L Register	13, 45
Enable (CCP1IE Bit)	18
Flag (CCP1IF Bit)	19
RC2/CCP1 Pin	7, 9
CCP2	45
CCP2CON Register	13, 45
CCPR2H Register	13, 45
CCPR2L Register	13, 45
Enable (CCP2IE Bit)	20

Flag (CCP2IF Bit)	21
RC1/T1OSI/CCP2 Pin	7, 9
Interaction of Two CCP Modules	45
Timer Resources	45
Timing Diagram	112
CCP1CON Register	45
CCP1M3:CCP1M0 Bits	45
CCP1X:CCP1Y Bits	45
CCP2CON Register	45
CCP2M3:CCP2M0 Bits	45
CCP2X:CCP2Y Bits	45
Code Protection	81, 94
CP1:CP0 Bits	81
Compare (CCP Module)	47
Block Diagram	47
CCP Pin Configuration	47
CCPR1H:CCPR1L Registers	47
Software Interrupt	47
Special Event Trigger	41, 47, 80
Timer1 Mode Selection	47
Configuration Bits	81
Conversion Considerations	137

### D

Data Memory	11
Bank Select (RP1:RP0 Bits)	11, 15
General Purpose Registers	11
Register File Map	12
Special Function Registers	12, 13
DC Characteristics	102, 104
Development Support	97
Development Tools	97
Device Differences	137
Direct Addressing	24

### E

Electrical Characteristics	101
Errata	4
External Power-on Reset Circuit	85

### F

Firmware Instructions	95
ftp site	147
Fuzzy Logic Dev. System (fuzzyTECH®-MP)	99

### I

I/O Ports	25
I <sup>2</sup> C (SSP Module)	56
ACK Pulse	56, 57, 58, 59, 60
Addressing	57
Block Diagram	56
Buffer Full Status (BF Bit)	52
Clock Polarity Select (CKP Bit)	53
Data/Address (D/ $\bar{A}$ Bit)	52
Master Mode	60
Mode Select (SSPM3:SSPM0 Bits)	53
Multi-Master Mode	60
Read/Write Bit Information (R/ $\bar{W}$ Bit)	52, 57, 58, 59
Receive Overflow Indicator (SSPOV Bit)	53
Reception	58
Reception Timing Diagram	58
Serial Clock (RC3/SCK/SCL)	59
Slave Mode	56
Start (S Bit)	52, 60
Stop (P Bit)	52, 60
Synchronous Serial Port Enable (SSPEN Bit)	53
Timing Diagram, Data	119
Timing Diagram, Start/Stop Bits	118
Transmission	59
Update Address (UA Bit)	52
ICEPIC Low-Cost PIC16CXXX In-Circuit Emulator	97

# PIC16C63A/65B/73B/74B

ID Locations .....	81, 94	Memory Organization .....	
In-Circuit Serial Programming (ICSP) .....	81, 94	Data Memory .....	11
Indirect Addressing .....	24	Program Memory .....	11
FSR Register .....	11, 13, 24	MP-DriveWay™ - Application Code Generator .....	99
INDF Register .....	13	MPLAB C .....	99
Instruction Format .....	95	MPLAB Integrated Development Environment .....	
Instruction Set .....	95	Software .....	98
Summary Table .....	96	<b>O</b>	
INTCON Register .....	13, 17	On-Line Support .....	147
GIE Bit .....	17	OPCODE Field Descriptions .....	95
INTE Bit .....	17	OPTION_REG Register .....	14, 16
INTF Bit .....	17	INTEDG Bit .....	16
PEIE Bit .....	17	PS2:PS0 Bits .....	16, 37
RBIE Bit .....	17	PSA Bit .....	16, 37
RBIF Bit .....	17, 27	RBPJ Bit .....	16
TOIE Bit .....	17	T0CS Bit .....	16, 37
T0IF Bit .....	17	T0SE Bit .....	16, 37
Interrupt Sources .....	81, 90	OSC1/CLKIN Pin .....	7, 8
A/D Conversion Complete .....	77	OSC2/CLKOUT Pin .....	7, 8
Block Diagram .....	90	Oscillator Configuration .....	81, 82
Capture Complete (CCP) .....	46	HS .....	82, 86
Compare Complete (CCP) .....	47	LP .....	82, 86
Interrupt on Change (RB7:RB4) .....	27	RC .....	82, 83, 86
RB0/INT Pin, External .....	7, 8, 91	Selection (FOSC1:FOSC0 Bits) .....	81
SSP Receive/Transmit Complete .....	51	XT .....	82, 86
TMR0 Overflow .....	38, 91	Oscillator, Timer1 .....	39, 41
TMR1 Overflow .....	39, 41	Oscillator, WDT .....	92
TMR2 to PR2 Match .....	44	<b>P</b>	
TMR2 to PR2 Match (PWM) .....	43, 48	Packaging .....	125
USART Receive/Transmit Complete .....	61	Paging, Program Memory .....	11, 23
Interrupts, Context Saving During .....	91	Parallel Slave Port (PSP) .....	9, 31, 35
Interrupts, Enable Bits .....		Block Diagram .....	35
A/D Converter Enable (ADIE Bit) .....	18	RE0/RD/AN5 Pin .....	9, 34, 35
CCP1 Enable (CCP1IE Bit) .....	18, 46	RE1/WR/AN6 Pin .....	9, 34, 35
CCP2 Enable (CCP2IE Bit) .....	20	RE2/CS/AN7 Pin .....	9, 34, 35
Global Interrupt Enable (GIE Bit) .....	17, 90	Read Waveforms .....	36
Interrupt on Change (RB7:RB4) Enable .....		Read/Write Enable (PSPIE Bit) .....	18
(RBIE Bit) .....	17, 91	Read/Write Flag (PSPIF Bit) .....	19
Peripheral Interrupt Enable (PEIE Bit) .....	17	Select (PSPMODE Bit) .....	31, 33, 35
PSP Read/Write Enable (PSPIE Bit) .....	18	Timing Diagram .....	113
RB0/INT Enable (INTE Bit) .....	17	Write Waveforms .....	35
SSP Enable (SSPIE Bit) .....	18	PCON Register .....	22, 86
TMR0 Overflow Enable (TOIE Bit) .....	17	BOR Bit .....	22
TMR1 Overflow Enable (TMR1IE Bit) .....	18	POR Bit .....	22
TMR2 to PR2 Match Enable (TMR2IE Bit) .....	18	PICDEM-1 Low-Cost PICmicro Demo Board .....	98
USART Receive Enable (RCIE Bit) .....	18	PICDEM-2 Low-Cost PIC16CXX Demo Board .....	98
USART Transmit Enable (TXIE Bit) .....	18	PICDEM-3 Low-Cost PIC16CXXX Demo Board .....	98
Interrupts, Flag Bits .....		PICMASTER® In-Circuit Emulator .....	97
A/D Converter Flag (ADIF Bit) .....	19, 77	PICSTART® Plus Entry Level Development System .....	97
CCP1 Flag (CCP1IF Bit) .....	19, 46, 47	PIE1 Register .....	14, 18
CCP2 Flag (CCP2IF Bit) .....	21	ADIE Bit .....	18
Interrupt on Change (RB7:RB4) Flag .....		CCP1IE Bit .....	18
(RBIF Bit) .....	17, 27, 91	PSPIE Bit .....	18
PSP Read/Write Flag (PSPIF Bit) .....	19	RCIE Bit .....	18
RB0/INT Flag (INTF Bit) .....	17	SSPIE Bit .....	18
SSP Flag (SSPIF Bit) .....	19	TMR1IE Bit .....	18
TMR0 Overflow Flag (T0IF Bit) .....	17, 91	TMR2IE Bit .....	18
TMR1 Overflow Flag (TMR1IF Bit) .....	19	TXIE Bit .....	18
TMR2 to PR2 Match Flag (TMR2IF Bit) .....	19	PIE2 Register .....	14, 20
USART Receive Flag (RCIF Bit) .....	19	CCP2IE Bit .....	20
USART Transmit Flag (TXIE Bit) .....	19	Pinout Descriptions .....	
<b>K</b>		PIC16C63A/PIC16C73B .....	7
KeelLoq® Evaluation and Programming Tools .....	99	PIC16C65B/PIC16C74B .....	8
<b>M</b>		PIR1 Register .....	13, 19
Master Clear ( $\overline{\text{MCLR}}$ ) .....	7, 8	ADIF Bit .....	19
MCLR Reset, Normal Operation .....	83, 86, 87	CCP1IF Bit .....	19
MCLR Reset, SLEEP .....	83, 86, 87	PSPIF Bit .....	19

# PIC16C63A/65B/73B/74B

RCIF Bit .....	19	Power-on Reset (POR).....	81, 83, 85, 86, 87
SSPIF Bit .....	19	Oscillator Start-up Timer (OST).....	81, 85
TMR1IF Bit.....	19	POR Status (POR Bit) .....	22
TMR2IF Bit.....	19	Power Control (PCON) Register.....	86
TXIF Bit.....	19	Power-down (PD Bit) .....	15, 83
PIR2 Register.....	13, 21	Power-on Reset Circuit, External .....	85
CCP2IF Bit.....	21	Power-up Timer (PWRT) .....	81, 85
Pointer, FSR .....	24	PWRT Enable (PWRT $\overline{E}$ Bit) .....	81
PORTA.....	7, 8	Time-out ( $\overline{TO}$ Bit).....	15, 83
Analog Port Pins .....	7, 8	Time-out Sequence .....	86
Initialization .....	25	Time-out Sequence on Power-up.....	88, 89
PORTA Register .....	13, 25	Timing Diagram .....	110
RA3:RA0 and RA5 Port Pins .....	25	Prescaler, Capture.....	46
RA4/T0CKI Pin.....	7, 8, 25	Prescaler, Timer0 .....	37
RA5/ $\overline{SS}$ /AN4 Pin.....	7, 8, 54	Assignment (PSA Bit) .....	16, 37
TRISA Register.....	14, 25	Block Diagram .....	38
PORTB.....	7, 8	Rate Select (PS2:PS0 Bits).....	16, 37
Initialization .....	27	Switching Between Timer0 and WDT.....	38
PORTB Register .....	13, 27	Prescaler, Timer1 .....	40
Pull-up Enable (RBPU Bit).....	16	Select (T1CKPS1:T1CKPS0 Bits).....	39
RB0/INT Edge Select (INTEDG Bit).....	16	Prescaler, Timer2 .....	48
RB0/INT Pin, External.....	7, 8, 91	Select (T2CKPS1:T2CKPS0 Bits).....	43
RB3:RB0 Port Pins .....	27	PRO MATE® II Universal Programmer .....	97
RB7:RB4 Interrupt on Change.....	91	Product Identification System .....	149
RB7:RB4 Interrupt on Change Enable (RBIE Bit).....	17, 91	Program Counter .....	
RB7:RB4 Interrupt on Change Flag (RBIF Bit) .....	17, 27, 91	PCL Register .....	13, 23
RB7:RB4 Port Pins .....	27	PCLATH Register .....	13, 23, 91
TRISB Register .....	14, 27	Reset Conditions .....	86
PORTC .....	7, 9	Program Memory .....	11
Block Diagram.....	29	Interrupt Vector.....	11
Initialization .....	29	Paging .....	11, 23
PORTC Register .....	13, 29	Program Memory Map.....	11
RC0/T1OSO/T1CKI Pin .....	7, 9	Reset Vector .....	11
RC1/T1OSI/CCP2 Pin.....	7, 9	Program Verification .....	94
RC2/CCP1 Pin .....	7, 9	Programming Pin (VPP) .....	7, 8
RC3/SCK/SCL Pin .....	7, 9, 54, 59	Programming, Device Instructions.....	95
RC4/SDI/SDA Pin .....	7, 9, 54	PWM (CCP Module).....	48
RC5/SDO Pin.....	7, 9, 54	Block Diagram .....	48
RC6/TX/CK Pin.....	7, 9, 62	CCPR1H:CCPR1L Registers .....	48
RC7/RX/DT Pin.....	7, 9, 62, 63	Duty Cycle .....	48
TRISC Register.....	14, 29, 61	Example Frequencies/Resolutions.....	49
PORTD .....	9, 35	Output Diagram .....	48
Block Diagram.....	31	Period .....	48
Parallel Slave Port (PSP) Function .....	31	Set-Up for PWM Operation.....	49
PORTD Register .....	13, 31	TMR2 to PR2 Match.....	43, 48
TRISD Register.....	14, 31	TMR2 to PR2 Match Enable (TMR2IE Bit) .....	18
PORTE.....	9	TMR2 to PR2 Match Flag (TMR2IF Bit) .....	19
Analog Port Pins .....	9, 34, 35	<b>Q</b> .....	
Block Diagram.....	33	Q-Clock.....	48
Input Buffer Full Status (IBF Bit) .....	33	<b>R</b> .....	
Input Buffer Overflow (IBOV Bit).....	33	RCSTA Register .....	62
Output Buffer Full Status (OBF Bit).....	33	CREN Bit .....	62
PORTE Register .....	13, 33	FERR Bit .....	62
PSP Mode Select (PSPMODE Bit) .....	31, 33, 35	OERR Bit .....	62
RE0/ $\overline{RD}$ /AN5 Pin.....	9, 34, 35	RX9 Bit .....	62
RE1/ $\overline{WR}$ /AN6 Pin.....	9, 34, 35	RX9D Bit.....	62
RE2/ $\overline{CS}$ /AN7 Pin.....	9, 34, 35	SPEN Bit.....	61, 62
TRISE Register .....	14, 33	SREN Bit .....	62
Postscaler, Timer2 .....		Reader Response.....	148
Select (TOUTPS3:TOUTPS0 Bits) .....	43	Register File .....	11
Postscaler, WDT .....	37	Register File Map .....	12
Assignment (PSA Bit) .....	16, 37	Reset .....	81, 83
Block Diagram.....	38	Block Diagram .....	84
Rate Select (PS2:PS0 Bits) .....	16, 37	Reset Conditions for All Registers.....	87
Switching Between Timer0 and WDT .....	38	Reset Conditions for PCON Register .....	86
		Reset Conditions for Program Counter .....	86
		Reset Conditions for STATUS Register .....	86

# PIC16C63A/65B/73B/74B

Timing Diagram.....	110	TMR1CS Bit.....	39
Revision History.....	137	TMR1ON Bit.....	39
<b>S</b>		T2CON Register.....	13, 43
SEEVAL® Evaluation and Programming System.....	99	T2CKPS1:T2CKPS0 Bits.....	43
SLEEP.....	81, 83, 93	TMR2ON Bit.....	43
Software Simulator (MPLAB-SIM).....	99	TOUTPS3:TOUTPS0 Bits.....	43
Special Features of the CPU.....	81	Timer0.....	37
Special Function Registers.....	12, 13	Block Diagram.....	37
Speed, Operating.....	1, 101	Clock Source Edge Select (T0SE Bit).....	16, 37
SPI (SSP Module)		Clock Source Select (T0CS Bit).....	16, 37
Block Diagram.....	54	Overflow Enable (T0IE Bit).....	17
Buffer Full Status (BF Bit).....	52	Overflow Flag (T0IF Bit).....	17, 91
Clock Edge Select (CKE Bit).....	52	Overflow Interrupt.....	38, 91
Clock Polarity Select (CKP Bit).....	53	RA4/T0CKI Pin, External Clock.....	7, 8
Data Input Sample Phase (SMP Bit).....	52	Timing Diagram.....	111
Mode Select (SSPM3:SSPM0 Bits).....	53	TMR0 Register.....	13
Receive Overflow Indicator (SSPOV Bit).....	53	Timer1.....	39
Serial Clock (RC3/SCK/SCL).....	54	Block Diagram.....	40
Serial Data In (RC4/SDI/SDA).....	54	Capacitor Selection.....	41
Serial Data Out (RC5/SDO).....	54	Clock Source Select (TMR1CS Bit).....	39
Slave Select (RA5/SS/AN4).....	54	External Clock Input Sync (T1SYNC Bit).....	39
Synchronous Serial Port Enable (SSPEN Bit).....	53	Module On/Off (TMR1ON Bit).....	39
SSP.....	51	Oscillator.....	39, 41
Enable (SSPIE Bit).....	18	Oscillator Enable (T1OSCEN Bit).....	39
Flag (SSPIF Bit).....	19	Overflow Enable (TMR1IE Bit).....	18
RA5/SS/AN4 Pin.....	7, 8	Overflow Flag (TMR1IF Bit).....	19
RC3/SCK/SCL Pin.....	7, 9	Overflow Interrupt.....	39, 41
RC4/SDI/SDA Pin.....	7, 9	RC0/T1OSO/T1CKI Pin.....	7, 9
RC5/SDO Pin.....	7, 9	RC1/T1OSI/CCP2 Pin.....	7, 9
RCSTA Register.....	13	Special Event Trigger (CCP).....	41, 47
SPBRG Register.....	14	T1CON Register.....	13, 39
SSPADD Register.....	14	Timing Diagram.....	111
SSPBUF Register.....	13	TMR1H Register.....	13, 39
SSPCON Register.....	13, 53	TMR1L Register.....	13, 39
SSPSTAT Register.....	14, 52	Timer2.....	
TMR2 Output for Clock Shift.....	43, 44	Block Diagram.....	44
TXSTA Register.....	14	PR2 Register.....	14, 43, 48
Write Collision Detect (WCOL Bit).....	53	SSP Clock Shift.....	43, 44
SSPCON Register.....	53	T2CON Register.....	13, 43
CKP Bit.....	53	TMR2 Register.....	13, 43
SSPEN Bit.....	53	TMR2 to PR2 Match Enable (TMR2IE Bit).....	18
SSPM3:SSPM0 Bits.....	53	TMR2 to PR2 Match Flag (TMR2IF Bit).....	19
SSPOV Bit.....	53	TMR2 to PR2 Match Interrupt.....	43, 44, 48
WCOL Bit.....	53	Timing Diagrams.....	
SSPSTAT Register.....	52	I <sup>2</sup> C Reception (7-bit Address).....	58
BF Bit.....	52	Time-out Sequence on Power-up.....	88, 89
CKE Bit.....	52	USART Asynchronous Master Transmission.....	67
D/Ā Bit.....	52	USART Asynchronous Reception.....	68
P bit.....	52, 60	USART Synchronous Reception.....	72
R/Ā Bit.....	52, 57, 58, 59	USART Synchronous Transmission.....	71
S Bit.....	52, 60	Wake-up from SLEEP via Interrupt.....	94
SMP Bit.....	52	Timing Diagrams and Specifications.....	108
UA Bit.....	52	A/D Conversion.....	122
Stack.....	23	Brown-out Reset (BOR).....	110
STATUS Register.....	13, 15, 91	Capture/Compare/PWM (CCP).....	112
C Bit.....	15	CLKOUT and I/O.....	109
DC Bit.....	15	External Clock.....	108
IRP Bit.....	15	I <sup>2</sup> C Bus Data.....	119
PD Bit.....	15, 83	I <sup>2</sup> C Bus Start/Stop Bits.....	118
RP1:RP0 Bits.....	15	Oscillator Start-up Timer (OST).....	110
T0 Bit.....	15, 83	Parallel Slave Port (PSP).....	113
Z Bit.....	15	Power-up Timer (PWRT).....	110
<b>T</b>		Reset.....	110
T1CON Register.....	13, 39	Timer0 and Timer1.....	111
T1CKPS1:T1CKPS0 Bits.....	39	USART Synchronous Receive ( Master/Slave).....	120
T1OSCEN Bit.....	39	USART Synchronous Transmission.....	
T1SYNC Bit.....	39		



# PIC16C63A/65B/73B/74B

( Master/Slave).....	120	Timing Diagram .....	94
Watchdog Timer (WDT).....	110	WDT Reset .....	87
TRISE Register .....	14, 33	Watchdog Timer (WDT).....	81, 92
IBF Bit .....	33	Block Diagram .....	92
IBOV Bit .....	33	Enable (WDTE Bit) .....	81, 92
OBF Bit .....	33	Programming Considerations.....	92
PSPMODE Bit.....	31, 33, 35	RC Oscillator .....	92
TXSTA Register .....	61	Time-out Period.....	92
BRGH Bit .....	61, 63	Timing Diagram .....	110
CSRC Bit.....	61	WDT Reset, Normal Operation.....	83, 86, 87
SYNC Bit.....	61	WDT Reset, SLEEP .....	83, 86, 87
TRMT Bit.....	61	WWW, On-Line Support .....	4, 147
TX9 Bit .....	61		
TX9D Bit.....	61		
TXEN Bit .....	61		
<b>U</b>			
USART .....	61		
Asynchronous Mode .....	66		
Master Transmission .....	67		
Receive Block Diagram .....	68		
Reception.....	68		
Transmit Block Diagram .....	66		
Baud Rate Generator (BRG).....	63		
Baud Rate Error, Calculating .....	63		
Baud Rate Formula.....	63		
Baud Rates, Asynchronous Mode (BRGH=0) .....	64		
Baud Rates, Asynchronous Mode (BRGH=1) .....	65		
Baud Rates, Synchronous Mode .....	64		
High Baud Rate Select (BRGH Bit) .....	61, 63		
Sampling.....	63		
Clock Source Select (CSRC Bit).....	61		
Continuous Receive Enable (CREN Bit).....	62		
Framing Error (FERR Bit) .....	62		
Mode Select (SYNC Bit) .....	61		
Overrun Error (OERR Bit) .....	62		
RC6/TX/CK Pin .....	7, 9		
RC7/RX/DT Pin.....	7, 9		
RCREG Register.....	13		
RCSTA Register .....	62		
Receive Data, 9th bit (RX9D Bit) .....	62		
Receive Enable (RCIE Bit).....	18		
Receive Enable, 9-bit (RX9 Bit) .....	62		
Receive Flag (RCIF Bit) .....	19		
Serial Port Enable (SPEN Bit).....	61, 62		
Single Receive Enable (SREN Bit) .....	62		
Synchronous Master Mode .....	70		
Reception.....	72		
Timing Diagram, Synchronous Receive .....	120		
Timing Diagram, Synchronous Transmission .....	120		
Transmission .....	71		
Synchronous Slave Mode .....	73		
Transmit Data, 9th Bit (TX9D).....	61		
Transmit Enable (TXEN Bit).....	61		
Transmit Enable (TXIE Bit) .....	18		
Transmit Enable, Nine-bit (TX9 Bit) .....	61		
Transmit Flag (TXIE Bit) .....	19		
Transmit Shift Register Status (TRMT Bit).....	61		
TXREG Register .....	13		
TXSTA Register .....	61		
<b>W</b>			
W Register .....	91		
Wake-up from SLEEP .....	81, 93		
Interrupts.....	86, 87		
MCLR Reset .....	87		

# PIC16C63A/65B/73B/74B

---

---

NOTES:

## ON-LINE SUPPORT

Microchip provides on-line support on the Microchip World Wide Web (WWW) site.

The web site is used by Microchip as a means to make files and information easily available to customers. To view the site, the user must have access to the Internet and a web browser, such as Netscape or Microsoft Explorer. Files are also available for FTP download from our FTP site.

### Connecting to the Microchip Internet Web Site

The Microchip web site is available by using your favorite Internet browser to attach to:

**[www.microchip.com](http://www.microchip.com)**

The file transfer site is available by using an FTP service to connect to:

**<ftp://ftp.futureone.com/pub/microchip>**

The web site and file transfer site provide a variety of services. Users may download files for the latest Development Tools, Data Sheets, Application Notes, User's Guides, Articles and Sample Programs. A variety of Microchip specific business information is also available, including listings of Microchip sales offices, distributors and factory representatives. Other data available for consideration is:

- Latest Microchip Press Releases
- Technical Support Section with Frequently Asked Questions
- Design Tips
- Device Errata
- Job Postings
- Microchip Consultant Program Member Listing
- Links to other useful web sites related to Microchip Products
- Conferences for products, Development Systems, technical information and more
- Listing of seminars and events

## Systems Information and Upgrade Hot Line

The Systems Information and Upgrade Line provides system users a listing of the latest versions of all of Microchip's development systems software products. Plus, this line provides information on how customers can receive any currently available upgrade kits. The Hot Line Numbers are:

1-800-755-2345 for U.S. and most of Canada, and

1-602-786-7302 for the rest of the world.

980106

**Trademarks:** The Microchip name, logo, PIC, PICSTART, PICMASTER and PRO MATE are registered trademarks of Microchip Technology Incorporated in the U.S.A. and other countries. PICmicro, FlexROM, MPLAB and fuzzyLAB are trademarks and SQTP is a service mark of Microchip in the U.S.A.

All other trademarks mentioned herein are the property of their respective companies.

# PIC16C63A/65B/73B/74B

---

---

## READER RESPONSE

It is our intention to provide you with the best documentation possible to ensure successful use of your Microchip product. If you wish to provide your comments on organization, clarity, subject matter, and ways in which our documentation can better serve you, please FAX your comments to the Technical Publications Manager at (602) 786-7578.

Please list the following information, and use this outline to provide us with your comments about this Data Sheet.

To: Technical Publications Manager Total Pages Sent  
RE: Reader Response  
From: Name \_\_\_\_\_  
Company \_\_\_\_\_  
Address \_\_\_\_\_  
City / State / ZIP / Country \_\_\_\_\_  
Telephone: (\_\_\_\_) \_\_\_\_\_ - \_\_\_\_\_ FAX: (\_\_\_\_) \_\_\_\_\_ - \_\_\_\_\_

Application (optional):  
Would you like a reply? \_\_\_Y \_\_\_N

Device: **PIC16C63A/65B/73B/74B** Literature Number: **DS30605A**

Questions:

1. What are the best features of this document?  
\_\_\_\_\_  
\_\_\_\_\_
2. How does this document meet your hardware and software development needs?  
\_\_\_\_\_  
\_\_\_\_\_
3. Do you find the organization of this data sheet easy to follow? If not, why?  
\_\_\_\_\_  
\_\_\_\_\_
4. What additions to the data sheet do you think would enhance the structure and subject?  
\_\_\_\_\_  
\_\_\_\_\_
5. What deletions from the data sheet could be made without affecting the overall usefulness?  
\_\_\_\_\_  
\_\_\_\_\_
6. Is there any incorrect or misleading information (what and where)?  
\_\_\_\_\_  
\_\_\_\_\_
7. How would you improve this document?  
\_\_\_\_\_  
\_\_\_\_\_
8. How would you improve our software, systems, and silicon products?  
\_\_\_\_\_  
\_\_\_\_\_

# PIC16C63A/65B/73B/74B

## PIC16C63A/65B/73B/74B PRODUCT IDENTIFICATION SYSTEM

To order or obtain information, e.g., on pricing or delivery, refer to the factory or the listed sales office.

<u>PART NO.</u>	<u>-XX</u>	<u>X</u>	<u>/XX</u>	<u>XXX</u>
Device	Frequency Range	Temperature Range	Package	Pattern
Device	PIC16C6X <sup>(1)</sup> , PIC16C6XT <sup>(2)</sup> ; V <sub>DD</sub> range 4.0V to 5.5V PIC16LC6X <sup>(1)</sup> , PIC16LC6XT <sup>(2)</sup> ; V <sub>DD</sub> range 2.5V to 5.5V PIC16C7X <sup>(1)</sup> , PIC16C7XT <sup>(2)</sup> ; V <sub>DD</sub> range 4.0V to 5.5V PIC16LC7X <sup>(1)</sup> , PIC16LC7XT <sup>(2)</sup> ; V <sub>DD</sub> range 2.5V to 5.5V			
Frequency Range	04 = 4 MHz 20 = 20 MHz			
Temperature Range	blank = 0°C to 70°C (Commercial) I = -40°C to +85°C (Industrial) E = -40°C to +125°C (Extended)			
Package	JW = Windowed CERDIP PQ = MQFP (Metric PQFP) PT = TQFP (Thin Quad Flatpack) SO = SOIC SP = Skinny plastic dip P = PDIP L = PLCC SS = SSOP			
Pattern	QTP, SQTP, Code or Special Requirements (blank otherwise)			

**Examples:**

a) PIC16C74B -04/P 301 = Commercial temp., PDIP package, 4 MHz, normal V<sub>DD</sub> limits, QTP pattern #301.

b) PIC16LC63A - 04I/SO = Industrial temp., SOIC package, 200 kHz, Extended V<sub>DD</sub> limits.

c) PIC16C65B - 20I/P = Industrial temp., PDIP package, 20MHz, normal V<sub>DD</sub> limits.

**Note 1:** C = CMOS  
LC = Low Power CMOS

**2:** T = in tape and reel - SOIC, SSOP, PLCC, QFP, TQ and FP packages only.

\* JW Devices are UV erasable and can be programmed to any device configuration. JW Devices meet the electrical requirement of each oscillator type (including LC devices).

# PIC16C63A/65B/73B/74B

---

NOTES:

# PIC16C63A/65B/73B/74B

---

NOTES:



**MICROCHIP**

## WORLDWIDE SALES AND SERVICE

### AMERICAS

#### Corporate Office

Microchip Technology Inc.  
2355 West Chandler Blvd.  
Chandler, AZ 85224-6199  
Tel: 602-786-7200 Fax: 602-786-7277  
Technical Support: 602 786-7627  
Web: <http://www.microchip.com>

#### Atlanta

Microchip Technology Inc.  
500 Sugar Mill Road, Suite 200B  
Atlanta, GA 30350  
Tel: 770-640-0034 Fax: 770-640-0307

#### Boston

Microchip Technology Inc.  
5 Mount Royal Avenue  
Marlborough, MA 01752  
Tel: 508-480-9990 Fax: 508-480-8575

#### Chicago

Microchip Technology Inc.  
333 Pierce Road, Suite 180  
Itasca, IL 60143  
Tel: 630-285-0071 Fax: 630-285-0075

#### Dallas

Microchip Technology Inc.  
14651 Dallas Parkway, Suite 816  
Dallas, TX 75240-8809  
Tel: 972-991-7177 Fax: 972-991-8588

#### Dayton

Microchip Technology Inc.  
Two Prestige Place, Suite 150  
Miamisburg, OH 45342  
Tel: 937-291-1654 Fax: 937-291-9175

#### Detroit

Microchip Technology Inc.  
42705 Grand River, Suite 201  
Novi, MI 48375-1727  
Tel: 248-374-1888 Fax: 248-374-2874

#### Los Angeles

Microchip Technology Inc.  
18201 Von Karman, Suite 1090  
Irvine, CA 92612  
Tel: 714-263-1888 Fax: 714-263-1338

#### New York

Microchip Technology Inc.  
150 Motor Parkway, Suite 202  
Hauppauge, NY 11788  
Tel: 516-273-5305 Fax: 516-273-5335

#### San Jose

Microchip Technology Inc.  
2107 North First Street, Suite 590  
San Jose, CA 95131  
Tel: 408-436-7950 Fax: 408-436-7955

### AMERICAS (continued)

#### Toronto

Microchip Technology Inc.  
5925 Airport Road, Suite 200  
Mississauga, Ontario L4V 1W1, Canada  
Tel: 905-405-6279 Fax: 905-405-6253

### ASIA/PACIFIC

#### Hong Kong

Microchip Asia Pacific  
RM 3801B, Tower Two  
Metroplaza  
223 Hing Fong Road  
Kwai Fong, N.T., Hong Kong  
Tel: 852-2-401-1200 Fax: 852-2-401-3431

#### India

Microchip Technology Inc.  
India Liaison Office  
No. 6, Legacy, Convent Road  
Bangalore 560 025, India  
Tel: 91-80-229-0061 Fax: 91-80-229-0062

#### Japan

Microchip Technology Intl. Inc.  
Benex S-1 6F  
3-18-20, Shinyokohama  
Kohoku-Ku, Yokohama-shi  
Kanagawa 222-0033 Japan  
Tel: 81-45-471- 6166 Fax: 81-45-471-6122

#### Korea

Microchip Technology Korea  
168-1, Youngbo Bldg. 3 Floor  
Samsung-Dong, Kangnam-Ku  
Seoul, Korea  
Tel: 82-2-554-7200 Fax: 82-2-558-5934

#### Shanghai

Microchip Technology  
RM 406 Shanghai Golden Bridge Bldg.  
2077 Yan'an Road West, Hong Qiao District  
Shanghai, PRC 200335  
Tel: 86-21-6275-5700 Fax: 86 21-6275-5060

### ASIA/PACIFIC (continued)

#### Singapore

Microchip Technology Singapore Pte Ltd.  
200 Middle Road  
#07-02 Prime Centre  
Singapore 189890  
Tel: 65-334-8870 Fax: 65-334-8850

#### Taiwan, R.O.C

Microchip Technology Taiwan  
10F-1C 207  
Tung Hua North Road  
Taipei, Taiwan, ROC  
Tel: 886-2-2717-7175 Fax: 886-2-2545-0139

### EUROPE

#### United Kingdom

Arizona Microchip Technology Ltd.  
505 Eskdale Road  
Winnersh Triangle  
Wokingham  
Berkshire, England RG41 5TU  
Tel: 44-1189-21-5858 Fax: 44-1189-21-5835

#### France

Arizona Microchip Technology SARL  
Zone Industrielle de la Bonde  
2 Rue du Buisson aux Fraises  
91300 Massy, France  
Tel: 33-1-69-53-63-20 Fax: 33-1-69-30-90-79

#### Germany

Arizona Microchip Technology GmbH  
Gustav-Heinemann-Ring 125  
D-81739 München, Germany  
Tel: 49-89-627-144 0 Fax: 49-89-627-144-44

#### Italy

Arizona Microchip Technology SRL  
Centro Direzionale Colleoni  
Palazzo Taurus 1 V. Le Colleoni 1  
20041 Agrate Brianza  
Milan, Italy  
Tel: 39-39-6899939 Fax: 39-39-6899883

7/7/98



*Microchip received ISO 9001 Quality System certification for its worldwide headquarters, design, and wafer fabrication facilities in January, 1997. Our field-programmable PICmicro™ 8-bit MCUs, Serial EEPROMs, related specialty memory products and development systems conform to the stringent quality standards of the International Standard Organization (ISO).*

All rights reserved. © 1998, Microchip Technology Incorporated, USA. 8/98 Printed on recycled paper.

Information contained in this publication regarding device applications and the like is intended for suggestion only and may be superseded by updates. No representation or warranty is given and no liability is assumed by Microchip Technology Incorporated with respect to the accuracy or use of such information, or infringement of patents or other intellectual property rights arising from such use or otherwise. Use of Microchip's products as critical components in life support systems is not authorized except with express written approval by Microchip. No licenses are conveyed, implicitly or otherwise, under any intellectual property rights. The Microchip logo and name are registered trademarks of Microchip Technology Inc. in the U.S.A. and other countries. All rights reserved. All other trademarks mentioned herein are the property of their respective companies.