



MX27C512

512K-BIT [64Kx8] CMOS EPROM

FEATURES

- 64K x 8 organization
- Single +5V power supply
- +12.5V programming voltage
- Fast access time: 45/55/70/90/100/120/150ns
- Totally static operation
- Completely TTL compatible
- Operating current: 30mA
- Standby current: 100uA
- Package type:
 - 28 pin plastic DIP
 - 32 pin PLCC
 - 28 pin 8 x 13.4 mm TSOP(I)

GENERAL DESCRIPTION

The MX27C512 is a 5V only, 512K-bit, ultraviolet Erasable Programmable Read Only Memory. It is organized as 64K words by 8 bits per word, operates from a single +5volt supply, has a static standby mode, and features fast single address location programming. All programming signals are TTL levels, requiring a single pulse. For programming outside from the system, existing EPROM

programmers may be used. The MX27C512 supports intelligent fast programming algorithm which can result in programming time of less than fifteen seconds.

This EPROM is packaged in industry standard 28 pin dual-in-line packages 32 lead PLCC, and 28 lead TSOP(I) packages.

PIN CONFIGURATIONS

PDIP

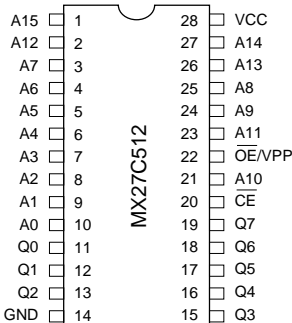

PLCC

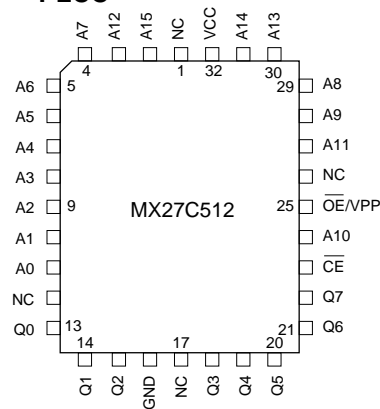

8 x 13.4mm 28TSOP(I)



BLOCK DIAGRAM

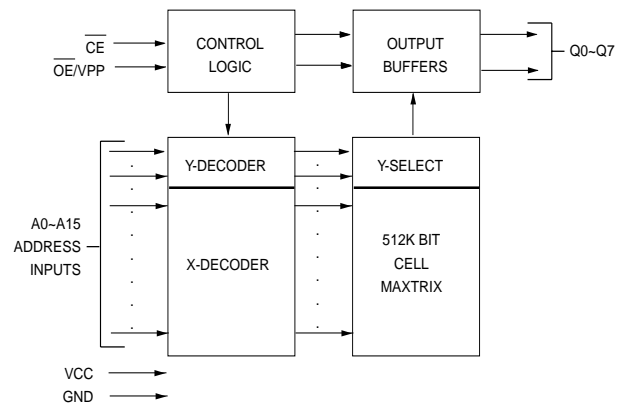

PIN DESCRIPTION

| SYMBOL | PIN NAME |
|-----------------|--|
| A0~A15 | Address Input |
| Q0~Q7 | Data Input/Output |
| \overline{CE} | Chip Enable Input |
| OE/VPP | Output Enable Input/Program Supply Voltage |
| NC | No Internal Connection |
| VCC | Power Supply Pin (+5V) |
| GND | Ground Pin |



FUNCTIONAL DESCRIPTION

THE PROGRAMMING OF THE MX27C512

When the MX27C512 is delivered, or it is erased, the chip has all 512K bits in the "ONE" or HIGH state. "ZEROS" are loaded into the MX27C512 through the procedure of programming.

For programming, the data to be programmed is applied with 8 bits in parallel to the data pins.

Vcc must be applied simultaneously or before Vpp, and removed simultaneously or after Vpp. When programming an MXIC EPROM, a 0.1uF capacitor is required across Vpp and ground to suppress spurious voltage transients which may damage the device.

FAST PROGRAMMING

The device is set up in the fast programming mode when the programming voltage $\overline{OE}/VPP = 12.75V$ is applied, with $VCC = 6.25V$, (Algorithm is shown in Figure 1). The programming is achieved by applying a single TTL low level 100us pulse to the \overline{CE} input after addresses and data line are stable. If the data is not verified, an additional pulse is applied for a maximum of 25 pulses. This process is repeated while sequencing through each address of the device. When the programming mode is completed, the data in all address is verified at $VCC = 5V \pm 10\%$.

PROGRAM INHIBIT MODE

Programming of multiple MX27C512s in parallel with different data is also easily accomplished by using the Program Inhibit Mode. Except for \overline{CE} and \overline{OE} , all like inputs of the parallel MX27C512 may be common. A TTL low-level program pulse applied to an MX27C512 \overline{CE} input with $\overline{OE}/VPP = 12.5 \pm 0.5V$ will program that MX27C512. A high-level \overline{CE} input inhibits the other MX27C512s from being programmed.

PROGRAM VERIFY MODE

Verification should be performed on the programmed bits to determine that they were correctly programmed. The verification should be performed with \overline{OE}/VPP and \overline{CE} , at VIL . Data should be verified tDV after the falling edge of \overline{CE} .

AUTO IDENTIFY MODE

The auto identify mode allows the reading out of a binary code from an EPROM that will identify its manufacturer and device type. This mode is intended for use by programming equipment for the purpose of automatically matching the device to be programmed with its corresponding programming algorithm. This mode is functional in the $25^{\circ}C \pm 5^{\circ}C$ ambient temperature range that is required when programming the MX27C512.

To activate this mode, the programming equipment must force $12.0 \pm 0.5(VH)$ on address line A9 of the device. Two identifier bytes may then be sequenced from the device outputs by toggling address line A0 from VIL to VIH . All other address lines must be held at VIL during auto identify mode.

Byte 0 ($A0 = VIL$) represents the manufacturer code, and byte 1 ($A0 = VIH$), the device identifier code. For the MX27C512, these two identifier bytes are given in the Mode Select Table. All identifiers for manufacturer and device codes will possess odd parity, with the MSB (Q7) defined as the parity bit.

READ MODE

The MX27C512 has two control functions, both of which must be logically satisfied in order to obtain data at the outputs. Chip Enable (\overline{CE}) is the power control and should be used for device selection. Output Enable (\overline{OE}) is the output control and should be used to gate data to the output pins, independent of device selection. Assuming that addresses are stable, address access time (tACC) is equal to the delay from \overline{CE} to output (tCE). Data is available at the outputs tOE after the falling edge of \overline{OE} , assuming that \overline{CE} has been LOW and addresses have been stable for at least tACC - tOE.

STANDBY MODE

The MX27C512 has a CMOS standby mode which reduces the maximum VCC current to 100uA. It is placed in CMOS standby when \overline{CE} is at $VCC \pm 0.3V$. The MX27C512 also has a TTL-standby mode which reduces the maximum VCC current to 1.5 mA. It is placed in TTL-standby when \overline{CE} is at VIH . When in standby mode, the outputs are in a high-impedance state, independent of the \overline{OE} input.

TWO-LINE OUTPUT CONTROL FUNCTION

To accommodate multiple memory connections, a two-line control function is provided to allow for:

1. Low memory power dissipation,
2. Assurance that output bus contention will not occur.

It is recommended that \overline{CE} be decoded and used as the primary device-selecting function, while \overline{OE} be made a common connection to all devices in the array and connected to the READ line from the system control bus. This assures that all deselected memory devices are in their low-power standby mode and that the output pins are only active when data is desired from a particular memory device.

SYSTEM CONSIDERATIONS

During the switch between active and standby conditions, transient current peaks are produced on the rising and falling edges of Chip Enable. The magnitude of these transient current peaks is dependent on the output capacitance loading of the device. At a minimum, a 0.1 uF ceramic capacitor (high frequency, low inherent inductance) should be used on each device between VCC and GND to minimize transient effects. In addition, to overcome the voltage drop caused by the inductive effects of the printed circuit board traces on EPROM arrays, a 4.7 uF bulk electrolytic capacitor should be used between VCC and GND for each eight devices. The location of the capacitor should be close to where the power supply is connected to the array.

MODE SELECT TABLE

| MODE | \overline{CE} | \overline{OE}/VPP | PINS | | OUTPUTS |
|----------------------|-----------------|---------------------|------|----|---------|
| | | | A0 | A9 | |
| Read | VIL | VIL | X | X | DOUT |
| Output Disable | VIL | VIH | X | X | High Z |
| Standby (TTL) | VIH | X | X | X | High Z |
| Standby (CMOS) | VCC±0.3V | X | X | X | High Z |
| Program | VIL | VPP | X | X | DIN |
| Program Verify | VIL | VIL | X | X | DOUT |
| Program Inhibit | VIH | VPP | X | X | High Z |
| Manufacturer Code(3) | VIL | VIL | VIL | VH | C2H |
| Device Code(3) | VIL | VIL | VIH | VH | 91H |

- NOTES:**
1. VH = 12.0 V ± 0.5 V
 2. X = Either VIH or VIL

3. A1 - A8 = A10 - A15 = VIL(For auto select)
4. See DC Programming Characteristics for VPP voltage during programming.

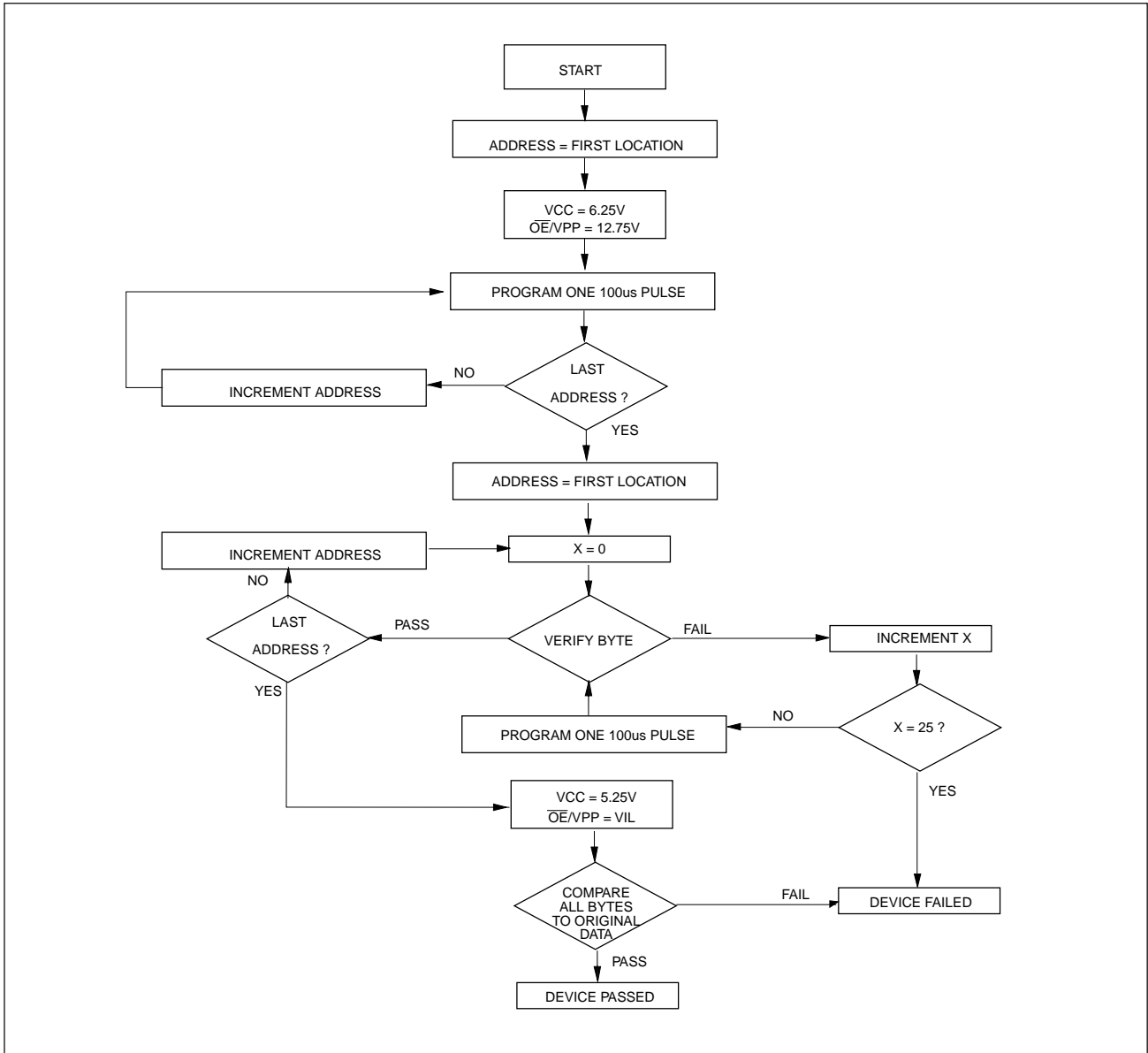
Figure1. FAST PROGRAMMING FLOW CHART

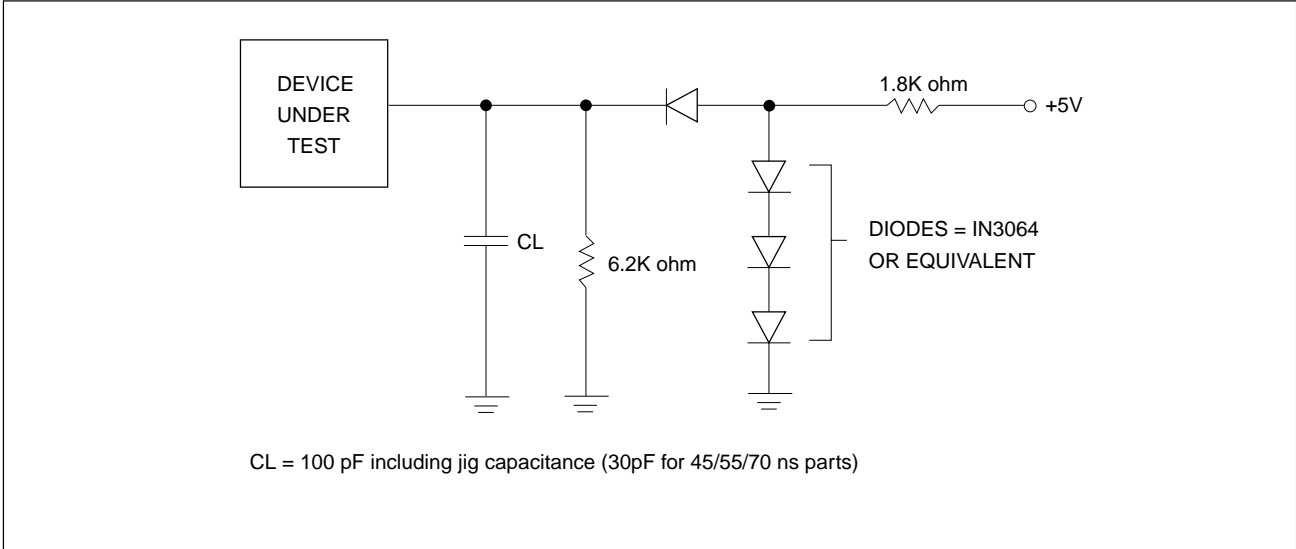
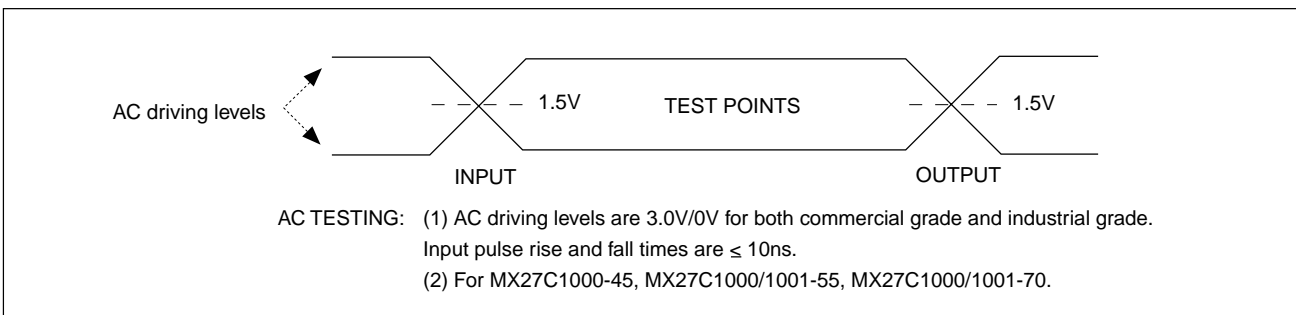
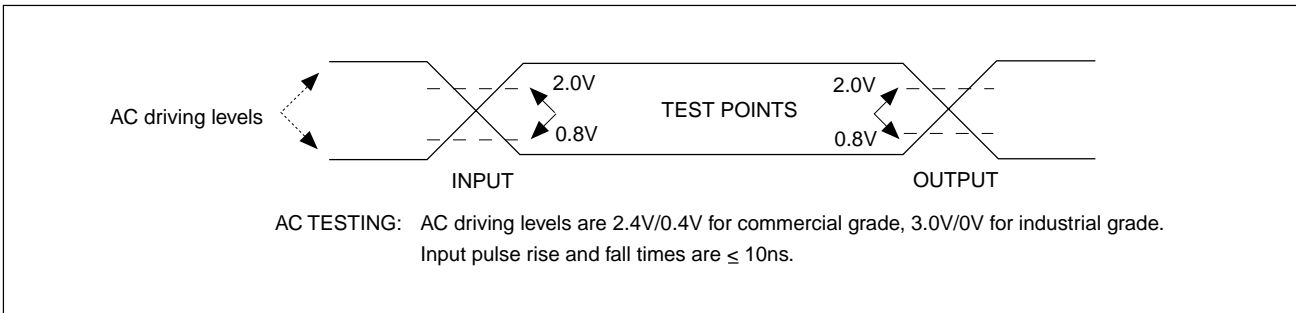
SWITCHING TEST CIRCUITS

SWITCHING TEST WAVEFORMS



ABSOLUTE MAXIMUM RATINGS

| RATING | VALUE |
|-------------------------------|---------------------|
| Ambient Operating Temperature | -40°C to 125°C |
| Storage Temperature | -65°C to 125°C |
| Applied Input Voltage | -0.5V to 7.0V |
| Applied Output Voltage | -0.5V to VCC + 0.5V |
| VCC to Ground Potential | -0.5V to 7.0V |
| A9 & Vpp | -0.5V to 13.5V |

NOTICE:

Stresses greater than those listed under ABSOLUTE MAXIMUM RATINGS may cause permanent damage to the device. This is a stress rating only and functional operation of the device at these or any other conditions above those indicated in the operational sections of this specification is not implied. Exposure to absolute maximum rating conditions for extended period may affect reliability.

NOTICE:

Specifications contained within the following tables are subject to change.

DC/AC Operating Conditions for Read Operation

| | | MX27C512 | | | | | | |
|-----------------------|------------|---------------|---------------|---------------|----------------|----------------|----------------|----------------|
| | | -45 | -55 | -70 | -90 | -10 | -12 | -15 |
| Operating Temperature | Commercial | 0°C to 55°C | 0°C to 70°C | 0°C to 70°C | 0°C to 70°C | 0°C to 70°C | 0°C to 70°C | 0°C to 70°C |
| | Industrial | -40°C to 85°C | -40°C to 85°C | -40°C to 85°C | -40°C to 85°C | -40°C to 85°C | -40°C to 85°C | -40°C to 85°C |
| | Automotive | | | | -40°C to 125°C | -40°C to 125°C | -40°C to 125°C | -40°C to 125°C |
| Vcc Power Supply | | 5V ± 5% | 5V ± 10% | 5V ± 10% | 5V ± 10% | 5V ± 10% | 5V ± 10% | 5V ± 10% |

DC CHARACTERISTICS

| SYMBOL | PARAMETER | MIN. | MAX. | UNIT | CONDITIONS |
|--------|-------------------------|------|-----------|------|-----------------------------|
| VOH | Output High Voltage | 2.4 | | V | IOH = -0.4mA |
| VOL | Output Low Voltage | | 0.4 | V | IOL = 2.1mA |
| VIH | Input High Voltage | 2.0 | VCC + 0.5 | V | |
| VIL | Input Low Voltage | -0.2 | 0.8 | V | |
| ILI | Input Leakage Current | -10 | 10 | uA | VIN = 0 to 5.5V |
| ILO | Output Leakage Current | -10 | 10 | uA | VOUT = 0 to 5.5V |
| ICC3 | VCC Power-Down Current | | 100 | uA | CE = VCC ± 0.3V |
| ICC2 | VCC Standby Current | | 1.5 | mA | CE = VIH |
| ICC1 | VCC Active Current | | 30 | mA | CE = VIL, f=5MHz, Iout =0mA |
| IPP | VPP Supply Current Read | | 10 | uA | CE = VIL, VPP = 5.5V |

CAPACITANCE TA = 25°C, f = 1.0 MHz (Sampled only)

| SYMBOL | PARAMETER | MIN. | MAX. | UNIT | CONDITIONS |
|--------|--------------------|------|------|------|------------|
| CIN | Input Capacitance | 8 | 12 | pF | VIN = 0V |
| COUT | Output Capacitance | 8 | 12 | pF | VOUT = 0V |
| Vpp | VPP Capacitance | 18 | 25 | pF | VPP = 0V |



AC CHARACTERISTICS

| SYMBOL | PARAMETER | 27C512-45 | | 27C512-55 | | 27C512-70 | | 27C512-90 | | UNIT | CONDITIONS |
|--------|--|-----------|------|-----------|------|-----------|------|-----------|------|------|---------------------------------------|
| | | MIN. | MAX. | MIN. | MAX. | MIN. | MAX. | MIN. | MAX. | | |
| tACC | Address to Output Delay | | 45 | | 55 | | 70 | | 90 | ns | $\overline{CE} = \overline{OE} = VIL$ |
| tCE | Chip Enable to Output Delay | | 45 | | 55 | | 70 | | 90 | ns | $\overline{OE} = VIL$ |
| tOE | Output Enable to Output Delay | | 25 | | 30 | | 35 | | 40 | ns | $\overline{CE} = VIL$ |
| tDF | \overline{OE} High to Output Float, or \overline{CE} High to Output Float | 0 | 17 | 0 | 20 | 0 | 20 | 0 | 25 | ns | |
| tOH | Output Hold from Address, \overline{CE} or \overline{OE} which ever occurred first | 0 | | 0 | | 0 | | 0 | | ns | |

| SYMBOL | PARAMETER | 27C512-10 | | 27C512-12 | | 27C512-15 | | UNIT | CONDITIONS |
|--------|--|-----------|------|-----------|------|-----------|------|------|---------------------------------------|
| | | MIN. | MAX. | MIN. | MAX. | MIN. | MAX. | | |
| tACC | Address to Output Delay | | 100 | | 120 | | 150 | ns | $\overline{CE} = \overline{OE} = VIL$ |
| tCE | Chip Enable to Output Delay | | 100 | | 120 | | 150 | ns | $\overline{OE} = VIL$ |
| tOE | Output Enable to Output Delay | | 45 | | 50 | | 65 | ns | $\overline{CE} = VIL$ |
| tDF | \overline{OE} High to Output Float, or \overline{CE} High to Output Float | 0 | 30 | 0 | 35 | 0 | 50 | ns | |
| tOH | Output Hold from Address, \overline{CE} or \overline{OE} which ever occurred first | 0 | | 0 | | 0 | | ns | |

DC PROGRAMMING CHARACTERISTICS TA = 25°C ± 5°C

| SYMBOL | PARAMETER | MIN. | MAX. | UNIT | CONDITIONS |
|--------|--------------------------------------|------|-----------|------|-----------------------|
| VOH | Output High Voltage | 2.4 | | V | IOH = -0.40mA |
| VOL | Output Low Voltage | | 0.4 | V | IOL = 2.1mA |
| VIH | Input High Voltage | 2.0 | VCC + 0.5 | V | |
| VIL | Input Low Voltage | -0.2 | 0.8 | V | |
| ILI | Input Leakage Current | -10 | 10 | uA | VIN = 0 to 5.5V |
| VH | A9 Auto Select Voltage | 11.5 | 12.5 | V | |
| ICC3 | VCC Supply Current(Program & Verify) | | 40 | mA | |
| IPP2 | VPP Supply Current(Program) | | 30 | mA | $\overline{CE} = VIL$ |
| VCC1 | Fast Programming Supply Voltage | 6.00 | 6.50 | V | |
| VPP1 | Fast Programming Voltage | 12.5 | 13.0 | V | |



AC PROGRAMMING CHARACTERISTICS TA = 25°C ± 5°C

| SYMBOL | PARAMETER | MIN. | MAX. | UNIT | CONDITIONS |
|--------|-------------------------------------|------|------|------|------------|
| tAS | Address Setup Time | 2 | | us | |
| tDS | Data Setup Time | 2 | | us | |
| tAH | Address Hold Time | 0 | | us | |
| tDH | Data Hold Time | 2 | | us | |
| tDFP | Chip Enable to Output Float Delay | 0 | 130 | ns | |
| tVPS | VPP Setup Time | 2 | | us | |
| tPW | \overline{CE} Program Pulse Width | 95 | 105 | us | |
| tVCS | Vcc Setup Time | 2 | | us | |
| tDV | Data Valid from \overline{CE} | | 150 | ns | |
| tOEH | \overline{OE}/VPP Hold Time | 2 | | ns | |
| tVR | \overline{OE}/VPP Recovery Time | 2 | | ns | |

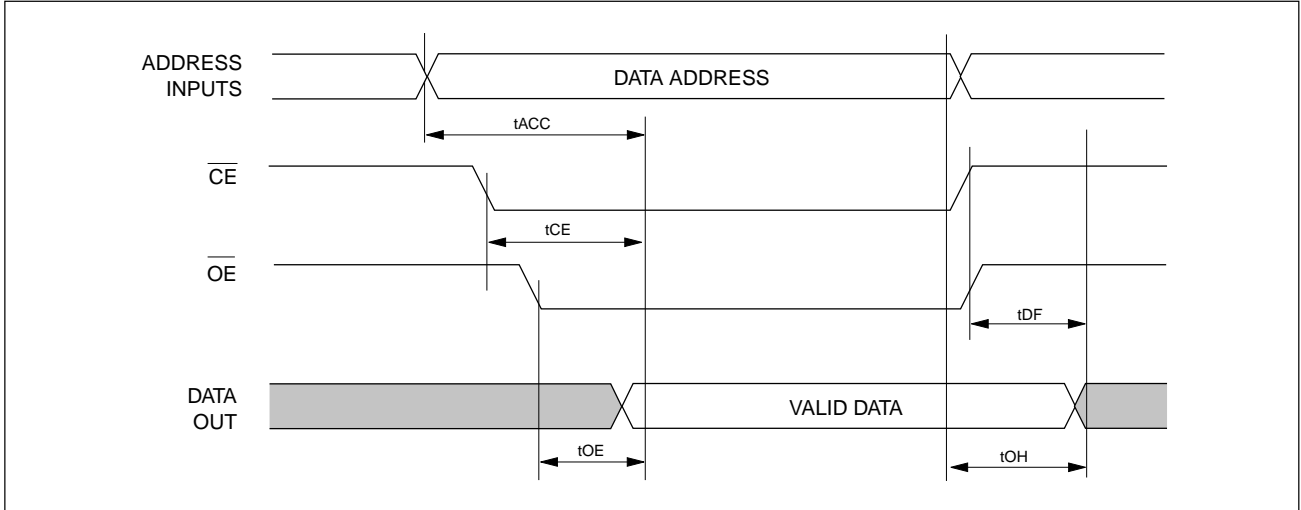
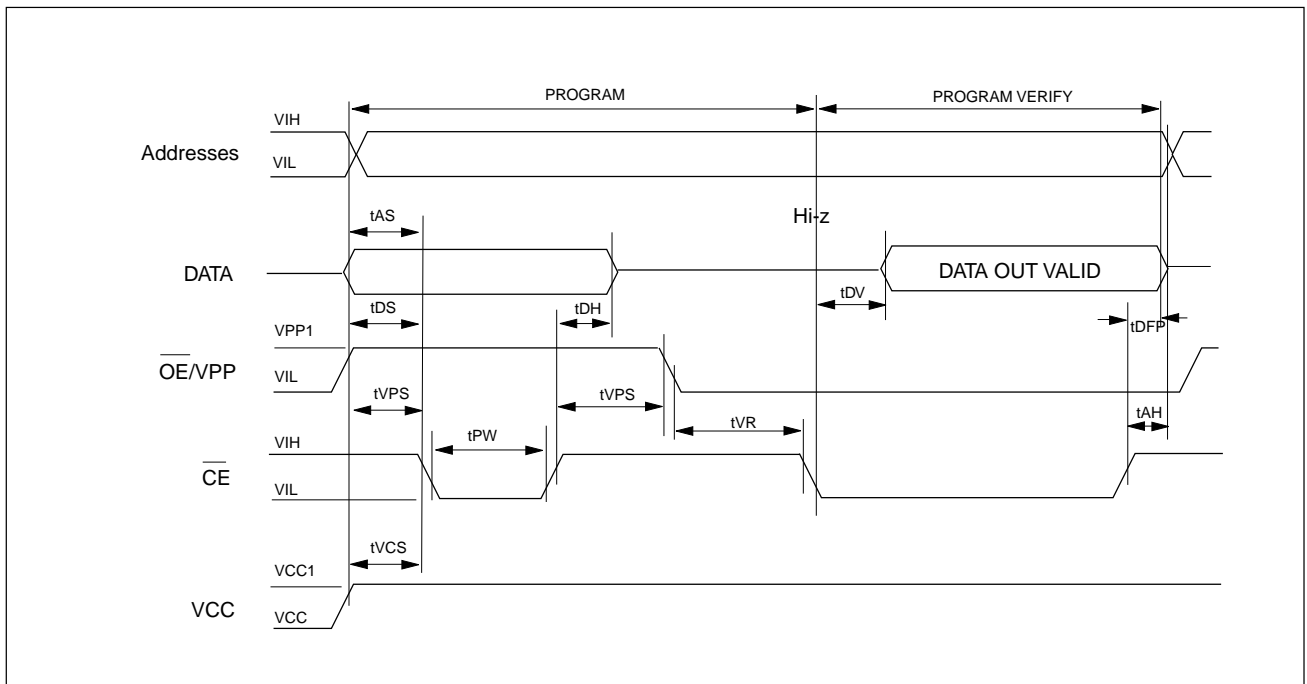
WAVEFORMS
READ CYCLE

FAST PROGRAMMING ALGORITHM WAVEFORM



ORDERING INFORMATION PLASTIC PACKAGE

| PART NO. | ACCESS TIME (ns) | OPERATING CURRENT MAX.(mA) | STANDBY CURRENT MAX.(uA) | OPERATING TEMPERATURE | PACKAGE |
|----------------|---------------------|-------------------------------|-----------------------------|--------------------------|----------------|
| MX27C512PC-45 | 45 | 30 | 100 | 0°C to 70°C | 28 Pin DIP |
| MX27C512QC-45 | 45 | 30 | 100 | 0°C to 70°C | 32 Pin PLCC |
| MX27C512TC-45 | 45 | 30 | 100 | 0°C to 70°C | 28 Pin TSOP(I) |
| MX27C512PC-55 | 55 | 30 | 100 | 0°C to 70°C | 28 Pin DIP |
| MX27C512QC-55 | 55 | 30 | 100 | 0°C to 70°C | 32 Pin PLCC |
| MX27C512TC-55 | 55 | 30 | 100 | 0°C to 70°C | 28 Pin TSOP(I) |
| MX27C512PC-70 | 70 | 30 | 100 | 0°C to 70°C | 28 Pin DIP |
| MX27C512QC-70 | 70 | 30 | 100 | 0°C to 70°C | 32 Pin PLCC |
| MX27C512TC-70 | 70 | 30 | 100 | 0°C to 70°C | 28 Pin TSOP(I) |
| MX27C512PC-90 | 90 | 30 | 100 | 0°C to 70°C | 28 Pin DIP |
| MX27C512QC-90 | 90 | 30 | 100 | 0°C to 70°C | 32 Pin PLCC |
| MX27C512TC-90 | 90 | 30 | 100 | 0°C to 70°C | 28 Pin TSOP(I) |
| MX27C512PC-12 | 120 | 30 | 100 | 0°C to 70°C | 28 Pin DIP |
| MX27C512QC-12 | 120 | 30 | 100 | 0°C to 70°C | 32 Pin PLCC |
| MX27C512TC-12 | 120 | 30 | 100 | 0°C to 70°C | 28 Pin TSOP(I) |
| MX27C512PC-15 | 150 | 30 | 100 | 0°C to 70°C | 28 Pin DIP |
| MX27C512QC-15 | 150 | 30 | 100 | 0°C to 70°C | 32 Pin PLCC |
| MX27C512TC-15 | 150 | 30 | 100 | 0°C to 70°C | 28 Pin TSOP(I) |
| MX27C512PI-45 | 45 | 30 | 100 | -40°C to 85°C | 28 Pin DIP |
| MX27C512QI-45 | 45 | 30 | 100 | -40°C to 85°C | 32 Pin PLCC |
| MX27C512TI-45 | 45 | 30 | 100 | -40°C to 85°C | 28 Pin TSOP(I) |
| MX27C512PI-55 | 55 | 30 | 100 | -40°C to 85°C | 28 Pin DIP |
| MX27C512QI-55 | 55 | 30 | 100 | -40°C to 85°C | 32 Pin PLCC |
| MX27C512TI-55 | 55 | 30 | 100 | -40°C to 85°C | 28 Pin TSOP(I) |
| MX27C512PI-70 | 70 | 30 | 100 | -40°C to 85°C | 28 Pin DIP |
| MX27C512QI-70 | 70 | 30 | 100 | -40°C to 85°C | 32 Pin PLCC |
| MX27C512TI-70 | 70 | 30 | 100 | -40°C to 85°C | 28 Pin TSOP(I) |
| MX27C512PI-90 | 90 | 30 | 100 | -40°C to 85°C | 28 Pin DIP |
| MX27C512QI-90 | 90 | 30 | 100 | -40°C to 85°C | 32 Pin PLCC |
| MX27C512TI-90 | 90 | 30 | 100 | -40°C to 85°C | 28 Pin TSOP(I) |
| MX27C512PI-12 | 120 | 30 | 100 | -40°C to 85°C | 28 Pin DIP |
| MX27C512QI-12 | 120 | 30 | 100 | -40°C to 85°C | 32 Pin PLCC |
| MX27C512TI-12 | 120 | 30 | 100 | -40°C to 85°C | 28 Pin TSOP(I) |
| MX27C512PI-15 | 150 | 30 | 100 | -40°C to 85°C | 28 Pin DIP |
| MX27C512QI-15 | 150 | 30 | 100 | -40°C to 85°C | 32 Pin PLCC |
| MX27C512TI-15 | 150 | 30 | 100 | -40°C to 85°C | 28 Pin TSOP(I) |
| MX27C512TA-90 | 90 | 30 | 100 | -40°C to 125°C | 28 Pin TSOP(I) |
| MX27C512TA-120 | 120 | 30 | 100 | -40°C to 125°C | 28 Pin TSOP(I) |

PACKAGE INFORMATION

28-PIN PLASTIC DIP (600 mil)

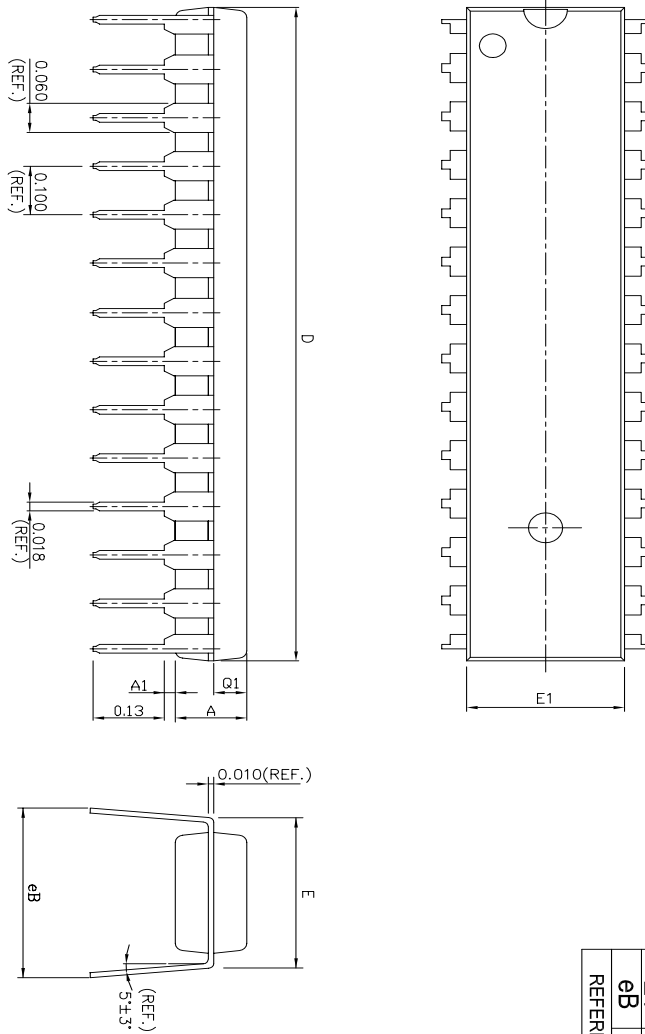

| Symbol | Dimension in inch (Ref.) | | | Dimension in mm (Base) | | |
|--------|--------------------------|-------|-------|------------------------|-------|-------|
| | Min | Nom | Max | Min | Nom | Max |
| A | 0.125 | 0.130 | 0.135 | 3.18 | 3.30 | 3.43 |
| A1 | 0.015 | 0.020 | 0.025 | 0.38 | 0.51 | 0.64 |
| Q1 | 0.055 | 0.060 | 0.065 | 1.40 | 1.52 | 1.65 |
| D | 1.345 | 1.350 | 1.355 | 34.16 | 34.29 | 34.42 |
| E | 0.305 | 0.310 | 0.315 | 7.75 | 7.87 | 8.00 |
| E1 | 0.283 | 0.288 | 0.293 | 7.19 | 7.32 | 7.44 |
| eB | 0.320 | 0.350 | 0.380 | 8.13 | 8.89 | 9.65 |

REFERENCE DOCUMENT : JEDEC SPEC -

| | | | |
|---|--------------------------|--------------------------|--------------|
| MIIIC 旺宏電子股份有限公司 Macromix International Co., Ltd. | | DWG. NO. 61110-0201.5 | |
| TITLE PACKAGE OUTLINE FOR PDIP 28L(300 MIL) | | | |
| DRAWN C.L.Chiang | APPROVED Dennis Chang | DATE 04-27-01 | UNIT INCH |
| TOLERANCE | | REVISION | |
| X ± | XX ±0.01 | ANGLE ±2° | |
| XXX±.002 | | 1 | |

32-PIN PLASTIC LEADED CHIP CARRIER (PLCC)

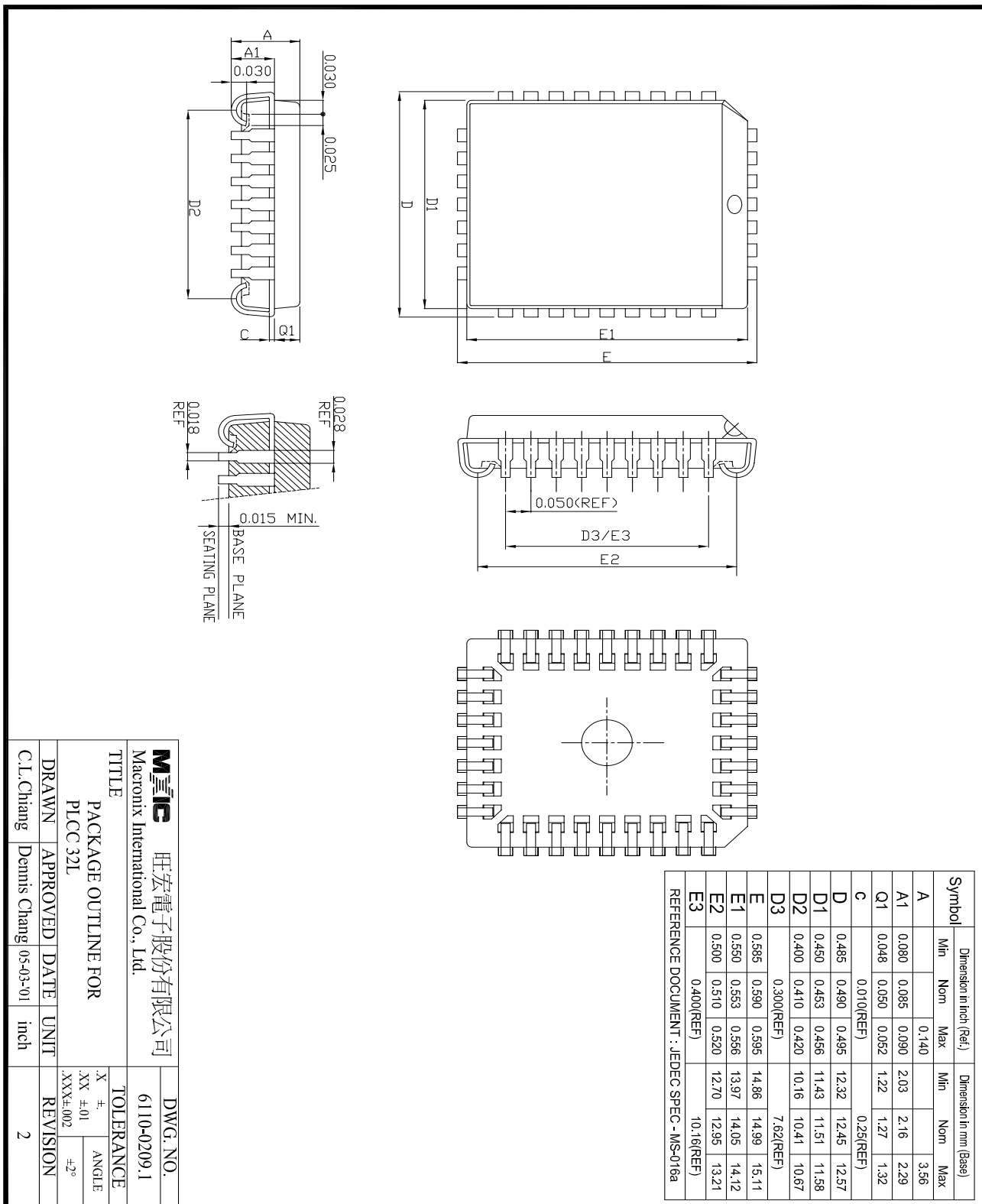

| | | | |
|---|---------------------------------|---------------------------------|----------------------|
| 旺宏電子股份有限公司 Macronix International Co., Ltd. | | DWG. NO. 61110-0209.1 | |
| TITLE PACKAGE OUTLINE FOR PLCC 32L | | | |
| TOLERANCE X ±. .XX ±.01 XXX±.002 | ANGLE ±2° | | REVISION 2 |
| DRAWN C.I.Chang | APPROVED Dennis Chang | DATE 05-03-01 | UNIT inch |

8 x 13.4mm 28-PIN PLASTIC TSOP

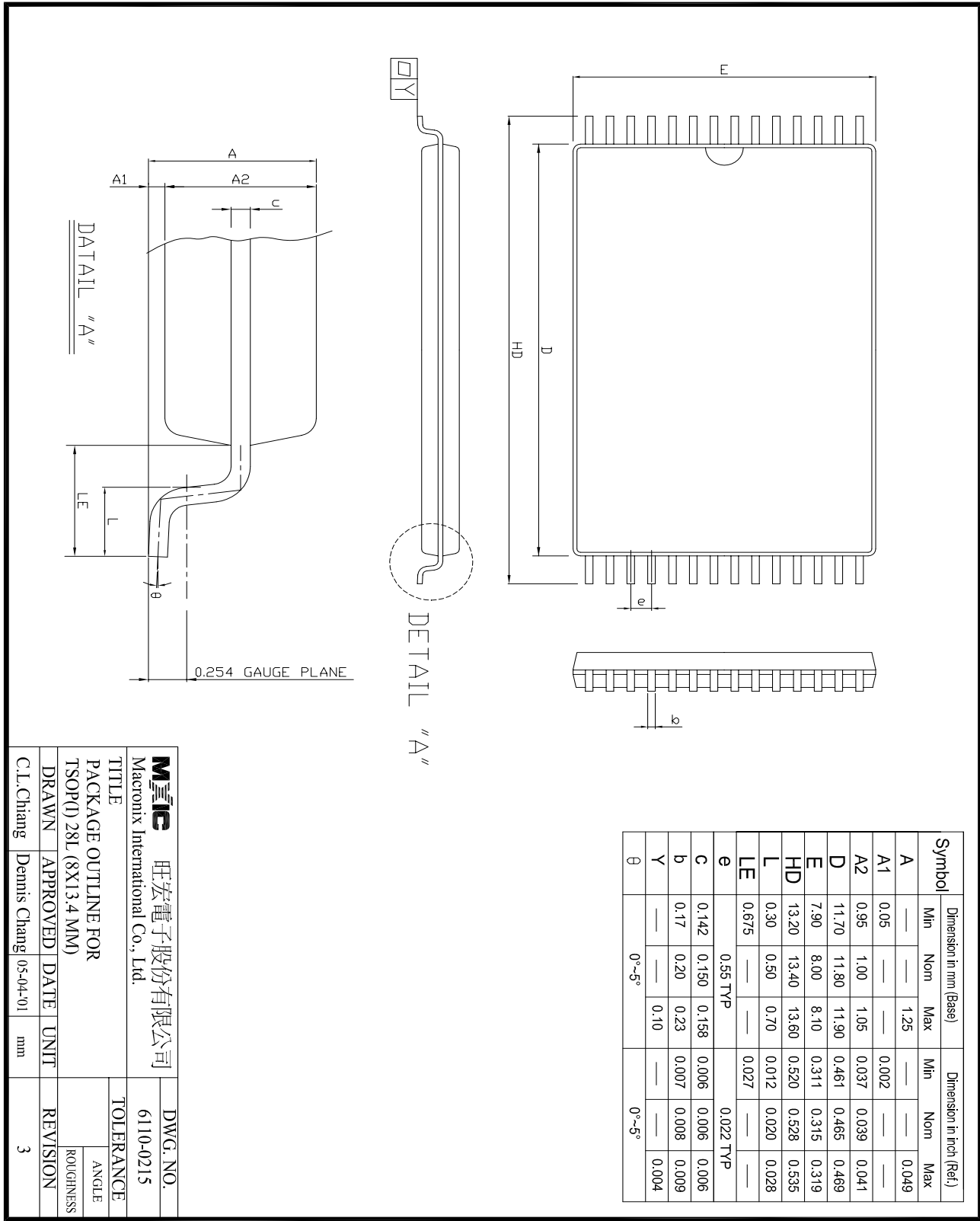



REVISION HISTORY

| Revision # | Description | Page | Date |
|-------------------|--|-------------|-------------|
| 3.3 | Programming Flow Chart corrected, programming verify after whole array programmed with 1 pulse. | | |
| 4.0 | 1) Reduce operating current change from 40mA to 30mA. 2) Add 28-TSOP(I) and 28-SOP packages offering. 3) Eliminate Interactive Programming Mode. | | |
| 4.1 | IPP 100uA --> 10uA | | 08/07/1997 |
| 4.2 | CDIP 70/90/100/120/150ns speed grades deleted from ordering information. | | 05/07/1998 |
| 4.3 | Cancel ceramic DIP package type | P1,2,10,12 | MAR/02/2000 |
| 4.4 | Remove 28-pin SOP Package | P1,10 | SEP/19/2001 |
| | Package Information format changed | P11~13 | |
| 4.5 | Add automotive grade | P6,10 | NOV/09/2001 |



MX27C512

MACRONIX INTERNATIONAL Co., LTD.

HEADQUARTERS:

TEL:+886-3-578-6688

FAX:+886-3-563-2888

EUROPE OFFICE:

TEL:+32-2-456-8020

FAX:+32-2-456-8021

JAPAN OFFICE:

TEL:+81-44-246-9100

FAX:+81-44-246-9105

SINGAPORE OFFICE:

TEL:+65-348-8385

FAX:+65-348-8096

TAIPEI OFFICE:

TEL:+886-2-2509-3300

FAX:+886-2-2509-2200

MACRONIX AMERICA, INC.

TEL:+1-408-453-8088

FAX:+1-408-453-8488

CHICAGO OFFICE:

TEL:+1-847-963-1900

FAX:+1-847-963-1909

[http : //www.macronix.com](http://www.macronix.com)