



# MX29F400T/B

## 4M-BIT [512Kx8/256Kx16] CMOS FLASH MEMORY

### FEATURES

- 524,288 x 8/262,144 x 16 switchable
- Single power supply operation
  - 5.0V only operation for read, erase and program operation
- Fast access time: 55/70/90/120ns
- Low power consumption
  - 40mA maximum active current(5MHz)
  - 1uA typical standby current
- Command register architecture
  - Byte/word Programming (7us/12us typical)
  - Sector Erase (Sector structure 16K-Bytex1, 8K-Bytex2, 32K-Bytex1, and 64K-Byte x7)
- Auto Erase (chip & sector) and Auto Program
  - Automatically erase any combination of sectors with Erase Suspend capability.
  - Automatically program and verify data at specified address
- Erase suspend/Erase Resume
  - Suspends an erase operation to read data from, or program data to, another sector that is not being erased, then resumes the erase.
- Status Reply
  - Data polling & Toggle bit for detection of program and erase cycle completion.
- Ready/Busy pin (RY/BY)
  - Provides a hardware method of detecting program or erase cycle completion.
  - Sector protect/unprotect for 5V only system or 5V/12V system.
- Sector protection
  - Hardware method to disable any combination of sectors from program or erase operations
- 100,000 minimum erase/program cycles
- Latch-up protected to 100mA from -1V to VCC+1V
- Boot Code Sector Architecture
  - T = Top Boot Sector
  - B = Bottom Boot Sector
- Low VCC write inhibit is equal to or less than 3.2V
- Package type:
  - 44-pin SOP
  - 48-pin TSOP
- Compatibility with JEDEC standard
  - Pinout and software compatible with single-power supply Flash
- 20 years data retention

### GENERAL DESCRIPTION

The MX29F400T/B is a 4-mega bit Flash memory organized as 512K bytes of 8 bits or 256K words of 16 bits. MXIC's Flash memories offer the most cost-effective and reliable read/write non-volatile random access memory. The MX29F400T/B is packaged in 44-pin SOP, 48-pin TSOP. It is designed to be reprogrammed and erased in system or in standard EPROM programmers.

The standard MX29F400T/B offers access time as fast as 55ns, allowing operation of high-speed microprocessors without wait states. To eliminate bus contention, the MX29F400T/B has separate chip enable ( $\overline{CE}$ ) and output enable ( $\overline{OE}$ ) controls.

MXIC's Flash memories augment EPROM functionality with in-circuit electrical erasure and programming. The MX29F400T/B uses a command register to manage this functionality. The command register allows for 100%

TTL level control inputs and fixed power supply levels during erase and programming, while maintaining maximum EPROM compatibility.

MXIC Flash technology reliably stores memory contents even after 100,000 erase and program cycles. The MXIC cell is designed to optimize the erase and programming mechanisms. In addition, the combination of advanced tunnel oxide processing and low internal electric fields for erase and program operations produces reliable cycling. The MX29F400T/B uses a 5.0V±10% VCC supply to perform the High Reliability Erase and auto Program/Erase algorithms.

The highest degree of latch-up protection is achieved with MXIC's proprietary non-epi process. Latch-up protection is proved for stresses up to 100 milliamps on address and data pin from -1V to VCC + 1V.

## PIN CONFIGURATIONS

### 44 SOP(500 mil)

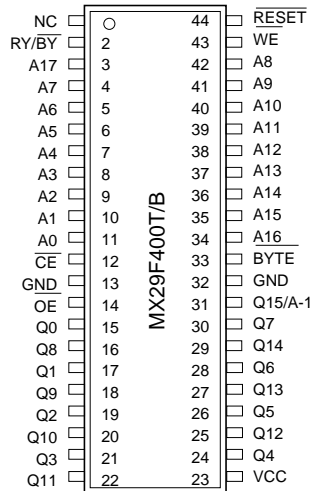

## PIN DESCRIPTION

SYMBOL	PIN NAME
A0~A17	Address Input
Q0~Q14	Data Input/Output
Q15/A-1	Q15(Word mode)/LSB addr(Byte mode)
$\overline{CE}$	Chip Enable Input
$\overline{WE}$	Write Enable Input
$\overline{BYTE}$	Word/Byte Selction input
$\overline{RESET}$	Hardware Reset Pin/Sector Protect Unlock
$\overline{OE}$	Output Enable Input
$\overline{RY/BY}$	Ready/Busy Output
VCC	Power Supply Pin (+5V)
GND	Ground Pin

### 48 TSOP (Standard Type) (12mm x 20mm)





**SECTOR STRUCTURE**

**MX29F400T TOP BOOT SECTOR ADDRESS TABLE**

Sector	A17	A16	A15	A14	A13	A12	Sector Size (Kbytes/ Kwords)	Address Range (in hexadecimal)	
								(x8) Address Range	(x16) Address Range
SA0	0	0	0	X	X	X	64/32	00000h-0FFFFh	00000h-07FFFh
SA1	0	0	1	X	X	X	64/32	10000h-1FFFFh	08000h-0FFFFh
SA2	0	1	0	X	X	X	64/32	20000h-2FFFFh	10000h-17FFFh
SA3	0	1	1	X	X	X	64/32	30000h-3FFFFh	18000h-1FFFFh
SA4	1	0	0	X	X	X	64/32	40000h-4FFFFh	20000h-27FFFh
SA5	1	0	1	X	X	X	64/32	50000h-5FFFFh	28000h-2FFFFh
SA6	1	1	0	X	X	X	64/32	60000h-6FFFFh	30000h-37FFFh
SA7	1	1	1	0	X	X	32/16	70000h-77FFFh	38000h-3BFFFh
SA8	1	1	1	1	0	0	8/4	78000h-79FFFh	3C000h-3CFFFh
SA9	1	1	1	1	0	1	8/4	7A000h-7BFFFh	3D000h-3DFFFh
SA10	1	1	1	1	1	X	16/8	7C000h-7FFFFh	3E000h-3FFFFh

**MX29F400B BOTTOM BOOT SECTOR ADDRESS TABLE**

Sector	A17	A16	A15	A14	A13	A12	Sector Size (Kbytes/ Kwords)	Address Range (in hexadecimal)	
								(x8) Address Range	(x16) Address Range
SA0	0	0	0	0	0	X	16/8	00000h-03FFFh	00000h-01FFFh
SA1	0	0	0	0	1	0	8/4	04000h-05FFFh	02000h-02FFFh
SA2	0	0	0	0	1	1	8/4	06000h-07FFFh	03000h-03FFFh
SA3	0	0	0	1	X	X	32/16	08000h-0FFFFh	04000h-07FFFh
SA4	0	0	1	X	X	X	64/32	10000h-1FFFFh	08000h-0FFFFh
SA5	0	1	0	X	X	X	64/32	20000h-2FFFFh	10000h-17FFFh
SA6	0	1	1	X	X	X	64/32	30000h-3FFFFh	18000h-1FFFFh
SA7	1	0	0	X	X	X	64/32	40000h-4FFFFh	20000h-27FFFh
SA8	1	0	1	X	X	X	64/32	50000h-5FFFFh	28000h-2FFFFh
SA9	1	1	0	X	X	X	64/32	60000h-6FFFFh	30000h-37FFFh
SA10	1	1	1	X	X	X	64/32	70000h-7FFFFh	38000h-3FFFFh

**Note:** Address range is A17~A-1 in byte mode and A17~A0 in word mode.

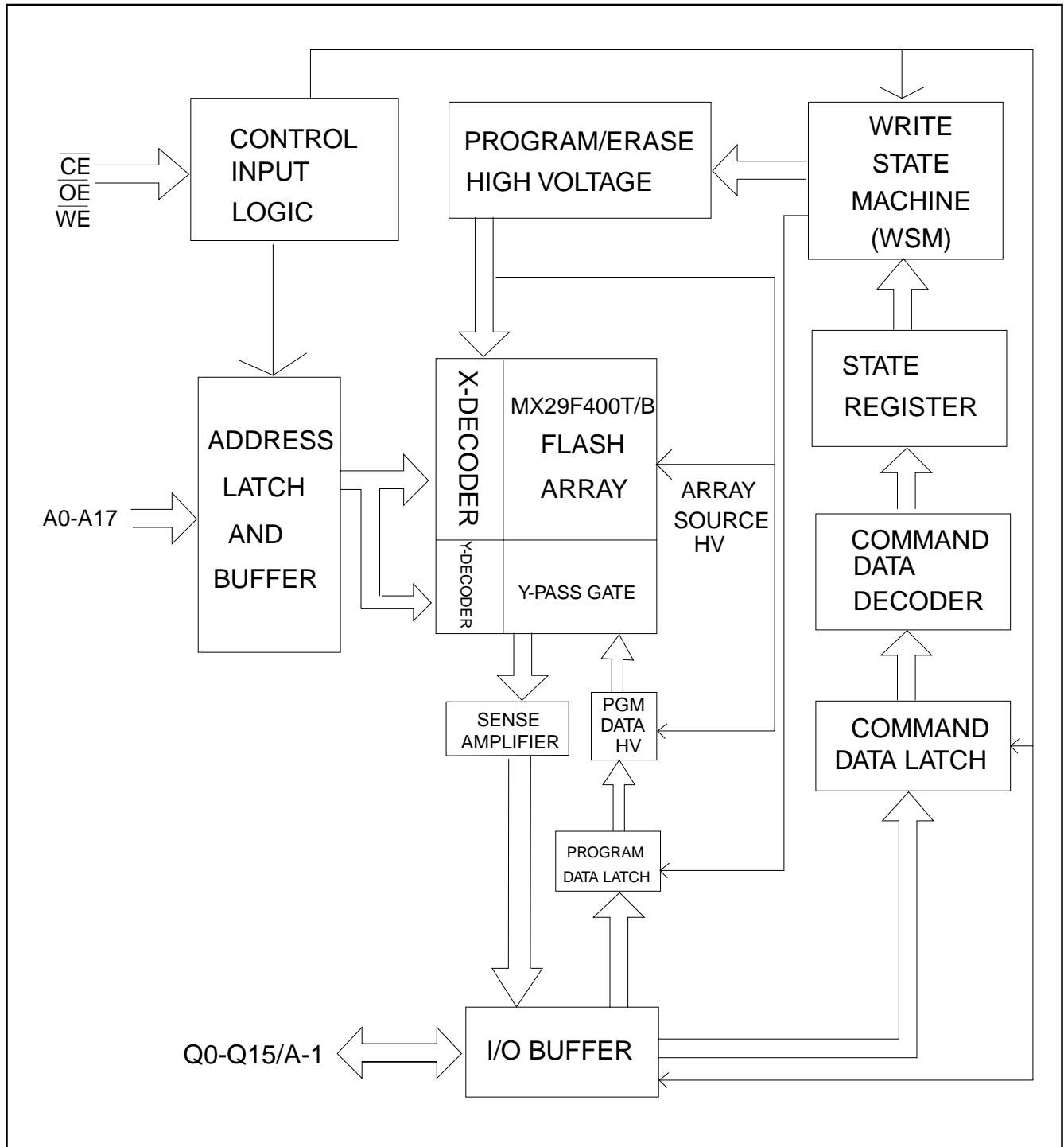
**BLOCK DIAGRAM**

## **AUTOMATIC PROGRAMMING**

The MX29F400T/B is byte programmable using the Automatic Programming algorithm. The Automatic Programming algorithm makes the external system do not need to have time out sequence nor to verify the data programmed. The typical chip programming time at room temperature of the MX29F400T/B is less than 4 seconds.

## **AUTOMATIC CHIP ERASE**

The entire chip is bulk erased using 10 ms erase pulses according to MXIC's Automatic Chip Erase algorithm. Typical erasure at room temperature is accomplished in less than 4 second. The Automatic Erase algorithm automatically programs the entire array prior to electrical erase. The timing and verification of electrical erase are controlled internally within the device.

## **AUTOMATIC SECTOR ERASE**

The MX29F400T/B is sector(s) erasable using MXIC's Auto Sector Erase algorithm. Sector erase modes allow sectors of the array to be erased in one erase cycle. The Automatic Sector Erase algorithm automatically programs the specified sector(s) prior to electrical erase. The timing and verification of electrical erase are controlled internally within the device.

## **AUTOMATIC PROGRAMMING ALGORITHM**

MXIC's Automatic Programming algorithm requires the user to only write program set-up commands (including 2 unlock write cycle and A0H) and a program command (program data and address). The device automatically times the programming pulse width, provides the program verification, and counts the number of sequences. A status bit similar to  $\overline{\text{DATA}}$  polling and a status bit toggling between consecutive read cycles, provide feedback to the user as to the status of the programming operation.

## **AUTOMATIC ERASE ALGORITHM**

MXIC's Automatic Erase algorithm requires the user to write commands to the command register using standard microprocessor write timings. The device will automatically pre-program and verify the entire array. Then the device automatically times the erase pulse width, provides the erase verification, and counts the number of sequences. A status bit toggling between consecutive read cycles provides feedback to the user as to the status of the programming operation.

Register contents serve as inputs to an internal state-machine which controls the erase and programming circuitry. During write cycles, the command register internally latches address and data needed for the programming and erase operations. During a system write cycle, addresses are latched on the falling edge, and data are latched on the rising edge of  $\overline{\text{WE}}$  or  $\overline{\text{CE}}$ , whichever happens first .

MXIC's Flash technology combines years of EPROM experience to produce the highest levels of quality, reliability, and cost effectiveness. The MX29F400T/B electrically erases all bits simultaneously using Fowler-Nordheim tunneling. The bytes are programmed by using the EPROM programming mechanism of hot electron injection.

During a program cycle, the state-machine will control the program sequences and command register will not respond to any command set. During a Sector Erase cycle, the command register will only respond to Erase Suspend command. After Erase Suspend is completed, the device stays in read mode. After the state machine has completed its task, it will allow the command register to respond to its full command set.

**TABLE1. SOFTWARE COMMAND DEFINITIONS**

Command	Bus Cycle	First Bus Cycle		Second Bus Cycle		Third Bus Cycle		Fourth Bus Cycle		Fifth Bus Cycle		Sixth Bus Cycle	
		Addr	Data	Addr	Data	Addr	Data	Addr	Data	Addr	Data	Addr	Data
Reset	1	XXXH	F0H										
Read	1	RA	RD										
Read Silicon ID	Word	4	555H AAH	2AAH 55H	555H 90H	ADI DDI							
	Byte	4	AAAH AAH	555H 55H	AAAH 90H	ADI DDI							
Sector Protect Verify	Word	4	555H AAH	2AAH 55H	555H 90H	(SA) x02H	XX00H						
	Byte	4	AAAH AAH	555H 55H	AAAH 90H	(SA) x04H	00H 01H						
Program	Word	4	555H AAH	2AAH 55H	555H A0H	PA PD							
	Byte	4	AAAH AAH	555H 55H	AAAH A0H	PA PD							
Chip Erase	Word	6	555H AAH	2AAH 55H	555H 80H	555H AAH	2AAH 55H	555H 10H					
	Byte	6	AAAH AAH	555H 55H	AAAH 80H	AAAH AAH	555H 55H	AAAH 10H					
Sector Erase	Word	6	555H AAH	2AAH 55H	555H 80H	555H AAH	2AAH 55H	SA 30H					
	Byte	6	AAAH AAH	555H 55H	AAAH 80H	AAAH AAH	555H 55H	SA 30H					
Sector Erase Suspend	1	XXXH	B0H										
Sector Erase Resume	1	XXXH	30H										
Unlock for sector protect/unprotect	6	555H	AAH	2AAH 55H	555H 80H	555H AAH	2AAH 55H	555H 20H					

**Note:**

- ADI = Address of Device identifier; A1=0, A0 = 0 for manufacture code, A1=0, A0 = 1 for device code, A2~A17=do not care. (Refer to table 3)  
DDI = Data of Device identifier : C2H for manufacture code, 23H/ABH (x8) and 2223H/22ABH (x16) for device code.  
X = X can be VIL or VIH  
RA=Address of memory location to be read.  
RD=Data to be read at location RA.
- PA = Address of memory location to be programmed.  
PD = Data to be programmed at location PA.  
SA = Address to the sector to be erased.
- The system should generate the following address patterns: 555H or 2AAH to Address A10~A0 in word mode/AAAH or 555H to Address A10~A-1 in byte mode.  
Address bit A11~A17=X=Don't care for all address commands except for Program Address (PA) and Sector Address (SA). Write Sequence may be initiated with A11~A17 in either state.
- For Sector Protect Verify operation: If read out data is 01H, it means the sector has been protected. If read out data is 00H, it means the sector is still not being protected.

**COMMAND DEFINITIONS**

Device operations are selected by writing specific address and data sequences into the command register. Writing incorrect address and data values or writing them in the improper sequence will reset the device to the read mode. Table 1 defines the valid register command sequences.

Note that the Erase Suspend (B0H) and Erase Resume (30H) commands are valid only while the Sector Erase operation is in progress. Either of the two reset command sequences will reset the device(when applicable).

**TABLE 2. MX29F400T/B BUS OPERATION**

Mode	Pins	$\overline{CE}$	$\overline{OE}$	$\overline{WE}$	A0	A1	A6	A9	Q0 ~ Q15
Read Silicon ID		L	L	H	L	L	X	$V_{ID}(2)$	C2H (Byte mode)
Manufacturer Code(1)									00C2H (Word mode)
Read Silicon ID		L	L	H	H	L	X	$V_{ID}(2)$	23H/ABH (Byte mode)
Device Code(1)									2223H/22ABH (Word mode)
Read		L	L	H	A0	A1	A6	A9	$D_{OUT}$
Standby		H	X	X	X	X	X	X	HIGH Z
Output Disable		L	H	H	X	X	X	X	HIGH Z
Write		L	H	L	A0	A1	A6	A9	$D_{IN}(3)$
Sector Protect with 12V system(6)		L	$V_{ID}(2)$	L	X	X	L	$V_{ID}(2)$	X
Chip Unprotect with 12V system(6)		L	$V_{ID}(2)$	L	X	X	H	$V_{ID}(2)$	X
Verify Sector Protect with 12V system		L	L	H	X	H	X	$V_{ID}(2)$	Code(5)
Sector Protect without 12V system (6)		L	H	L	X	X	L	H	X
Chip Unprotect without 12V system (6)		L	H	L	X	X	H	H	X
Verify Sector Protect/Unprotect without 12V system (7)		L	L	H	X	H	X	H	Code(5)
Reset		X	X	X	X	X	X	X	HIGH Z

**NOTES:**

1. Manufacturer and device codes may also be accessed via a command register write sequence. Refer to Table 1.
2. VID is the Silicon-ID-Read high voltage, 11.5V to 12.5V.
3. Refer to Table 1 for valid Data-In during a write operation.
4. X can be VIL or VIH.
5. Code=00H/XX00H means unprotected.  
Code=01H/XX01H means protected.  
A17~A12=Sector address for sector protect.
6. Refer to sector protect/unprotect algorithm and waveform.  
Must issue "unlock for sector protect/unprotect" command before "sector protect/unprotect without 12V system" command.
7. The "verify sector protect/unprotect without 12V system" is only following "Sector protect/unprotect without 12V system" command.

### READ/RESET COMMAND

The read or reset operation is initiated by writing the read/reset command sequence into the command register. Microprocessor read cycles retrieve array data. The device remains enabled for reads until the command register contents are altered.

If program-fail or erase-fail happen, the write of F0H will reset the device to abort the operation. A valid command must then be written to place the device in the desired state.

### SILICON-ID-READ COMMAND

Flash memories are intended for use in applications where the local CPU alters memory contents. As such, manufacturer and device codes must be accessible while the device resides in the target system. PROM programmers typically access signature codes by raising A9 to a high voltage. However, multiplexing high voltage onto address lines is not generally desired system design practice.

The MX29F400T/B contains a Silicon-ID-Read operation to supplement traditional PROM programming methodology. The operation is initiated by writing the read silicon ID command sequence into the command register. Following the command write, a read cycle with A1=VIL, A0=VIL retrieves the manufacturer code of C2H/00C2H. A read cycle with A1=VIL, A0=VIH returns the device code of 23H/2223H for MX29F400T, ABH/22ABH for MX29F400B.

### SET-UP AUTOMATIC CHIP/SECTOR ERASE COMMANDS

Chip erase is a six-bus cycle operation. There are two "unlock" write cycles. These are followed by writing the "set-up" command 80H. Two more "unlock" write cycles are then followed by the chip erase command 10H.

The Automatic Chip Erase does not require the device to be entirely pre-programmed prior to executing the Automatic Chip Erase. Upon executing the Automatic Chip Erase, the device will automatically program and verify the entire memory for an all-zero data pattern. When the device is automatically verified to contain an all-zero pattern, a self-timed chip erase and verify begin. The erase and verify operations are completed when the data on Q7 is "1" at which time the device returns to the Read mode. The system is not required to provide any control or timing during these operations.

When using the Automatic Chip Erase algorithm, note that the erase automatically terminates when adequate erase margin has been achieved for the memory array (no erase verification command is required).

If the Erase operation was unsuccessful, the data on Q5 is "1" (see Table 4), indicating the erase operation exceed internal timing limit.

The automatic erase begins on the rising edge of the last  $\overline{WE}$  or  $\overline{CE}$ , whichever happens later, pulse in the command sequence and terminates when the data on Q7 is "1" and the data on Q6 stops toggling for two consecutive read cycles, at which time the device returns to the Read mode.

**TABLE 3. EXPANDED SILICON ID CODE**

Pins		A0	A1	Q15~Q8	Q7	Q6	Q5	Q4	Q3	Q2	Q1	Q0	Code(Hex)
Manufacture code	Word	VIL	VIL	00H	1	1	0	0	0	0	1	0	00C2H
	Byte	VIL	VIL	X	1	1	0	0	0	0	1	0	C2H
Device code for MX29F400T	Word	VIH	VIL	22H	0	0	1	0	0	0	1	1	2223H
	Byte	VIH	VIL	X	0	0	1	0	0	0	1	1	23H
Device code for MX29F400B	Word	VIH	VIL	22H	1	0	1	0	1	0	1	1	22ABH
	Byte	VIH	VIL	X	1	0	1	0	1	0	1	1	ABH
Sector Protection Verification		X	VIH	X	0	0	0	0	0	0	0	1	01H (Protected)
		X	VIH	X	0	0	0	0	0	0	0	0	00H (Unprotected)



## SECTOR ERASE COMMANDS

The Automatic Sector Erase does not require the device to be entirely pre-programmed prior to executing the Automatic Set-up Sector Erase command and Automatic Sector Erase command. Upon executing the Automatic Sector Erase command, the device will automatically program and verify the sector(s) memory for an all-zero data pattern. The system is not required to provide any control or timing during these operations.

When the sector(s) is automatically verified to contain an all-zero pattern, a self-timed sector erase and verify begin. The erase and verify operations are complete when the data on Q7 is "1" and the data on Q6 stops toggling for two consecutive read cycles, at which time the device returns to the Read mode. The system is not required to provide any control or timing during these operations.

When using the Automatic Sector Erase algorithm, note that the erase automatically terminates when adequate

erase margin has been achieved for the memory array (no erase verification command is required). Sector erase is a six-bus cycle operation. There are two "unlock" write cycles. These are followed by writing the set-up command 80H. Two more "unlock" write cycles are then followed by the sector erase command 30H. The sector address is latched on the falling edge of WE or CE, whichever happens later, while the command(data) is latched on the rising edge of WE or CE, whichever happens first. Sector addresses selected are loaded into internal register on the sixth falling edge of WE or CE, whichever happens later. Each successive sector load cycle started by the falling edge of WE or CE, whichever happens later, must begin within 30us from the rising edge of the preceding WE or CE, whichever happens First, otherwise, the loading period ends and internal auto sector erase cycle starts. (Monitor Q3 to determine if the sector erase timer window is still open, see section Q3, Sector Erase Timer.) Any command other than Sector Erase(30H) or Erase Suspend(B0H) during the time-out period resets the device to read mode.

**Table 4. Write Operation Status**

	Status	Q7 Note1	Q6	Q5 Note2	Q3	Q2	RY/ $\overline{\text{BY}}$	
In Progress	Byte Program in Auto Program Algorithm	$\overline{\text{Q7}}$	Toggle	0	N/A	No Toggle	0	
	Auto Erase Algorithm	0	Toggle	0	1	Toggle	0	
	Erase Suspended Mode	Erase Suspend Read (Erase Suspended Sector)	1	No Toggle	0	N/A	Toggle	1
		Erase Suspend Read (Non-Erase Suspended Sector)	Data	Data	Data	Data	Data	1
	Erase Suspend Program	$\overline{\text{Q7}}$	Toggle	0	N/A	N/A	0	
Exceeded Time Limits	Byte Program in Auto Program Algorithm	$\overline{\text{Q7}}$	Toggle	1	N/A	No Toggle	0	
	Auto Erase Algorithm	0	Toggle	1	1	Toggle	0	
	Erase Suspend Program	$\overline{\text{Q7}}$	Toggle	1	N/A	N/A	0	

**Note:**

1. Q7 and Q2 require a valid address when reading status information. Refer to the appropriate subsection for further details.
2. Q5 switches to '1' when an Auto Program or Auto Erase operation has exceeded the maximum timing limits. See "Q5:Exceeded Timing Limits " for more information.

## ERASE SUSPEND

This command only has meaning while the state machine is executing Automatic Sector Erase operation, and therefore will only be responded during Automatic Sector Erase operation. When the Erase Suspend command is written during a sector erase operation, the device requires a maximum of 100us to suspend the erase operations. However, When the Erase Suspend command is written during the sector erase time-out, the device immediately terminates the time-out period and suspends the erase operation. After this command has been executed, the command register will initiate erase suspend mode. The state machine will return to read mode automatically after suspend is ready. At this time, state machine only allows the command register to respond to the Read Memory Array, Erase Resume and program commands.

The system can determine the status of the program operation using the Q7 or Q6 status bits, just as in the standard program operation. After an erase-suspend program operation is complete, the system can once again read array data within non-suspended sectors.

## ERASE RESUME

This command will cause the command register to clear the suspend state and return back to Sector Erase mode but only if an Erase Suspend command was previously issued. Erase Resume will not have any effect in all other conditions. Another Erase Suspend command can be written after the chip has resumed erasing.

## SET-UP AUTOMATIC PROGRAM

### COMMANDS

To initiate Automatic Program mode, A three-cycle command sequence is required. There are two "unlock" write cycles. These are followed by writing the Automatic Program command A0H.

Once the Automatic Program command is initiated, the next  $\overline{WE}$  or  $\overline{CE}$ , pulse causes a transition to an active programming operation. Addresses are latched on the falling edge, and data are internally latched on the rising edge of the  $\overline{WE}$  or  $\overline{CE}$ , whichever happens first, pulse. The rising edge of  $\overline{WE}$  or  $\overline{CE}$ , whichever happens first, also begins the programming operation. The sys-

tem is not required to provide further controls or timings. The device will automatically provide an adequate internally generated program pulse and verify margin.

If the program operation was unsuccessful, the data on Q5 is "1" (see Table 4), indicating the program operation exceed internal timing limit. The automatic programming operation is completed when the data read on Q6 stops toggling for two consecutive read cycles and the data on Q7 and Q6 are equivalent to data written to these two bits, at which time the device returns to the Read mode (no program verify command is required).

### DATA POLLING-Q7

The MX29F400T/B also features  $\overline{Data}$  Polling as a method to indicate to the host system that the Automatic Program or Erase algorithms are either in progress or completed.

While the Automatic Programming algorithm is in operation, an attempt to read the device will produce the complement data of the data last written to Q7. Upon completion of the Automatic Program Algorithm an attempt to read the device will produce the true data last written to Q7. The  $\overline{Data}$  Polling feature is valid after the rising edge of the fourth  $\overline{WE}$  or  $\overline{CE}$ , whichever happens first, pulse of the four write pulse sequences for automatic program.

While the Automatic Erase algorithm is in operation, Q7 will read "0" until the erase operation is completed. Upon completion of the erase operation, the data on Q7 will read "1". The  $\overline{Data}$  Polling feature is valid after the rising edge of the sixth  $\overline{WE}$  or  $\overline{CE}$ , whichever happens first pulse of six write pulse sequences for automatic chip/sector erase.

The  $\overline{Data}$  Polling feature is active during Automatic Program/Erase algorithm or sector erase time-out. (see section Q3 Sector Erase Timer)

### RY/ $\overline{BY}$ : Ready/Busy

The RY/ $\overline{BY}$  is a dedicated, open-drain output pin that indicates whether an Automatic Erase/Program algorithm is in progress or complete. The RY/ $\overline{BY}$  status is valid after the rising edge of the final  $\overline{WE}$  or  $\overline{CE}$ , whichever happens first, pulse in the command sequence. Since RY/ $\overline{BY}$  is an open-drain output, several RY/ $\overline{BY}$  pins can be tied together in parallel with a pull-up resistor to Vcc.

If the output is low (Busy), the device is actively erasing or programming. (This includes programming in the Erase Suspend mode.) If the output is high (Ready), the device is ready to read array data (including during the Erase Suspend mode), or is in the standby mode.

Table 4 shows the outputs for  $\overline{RY/BY}$ .

### **Q6:Toggle BIT I**

Toggle Bit I on Q6 indicates whether an Automatic Program or Erase algorithm is in progress or complete, or whether the device has entered the Erase Suspend mode. Toggle Bit I may be read at any address, and is valid after the rising edge of the final  $\overline{WE}$  or  $\overline{CE}$ , whichever happens first, pulse in the command sequence (prior to the program or erase operation), and during the sector time-out.

During an Automatic Program or Erase algorithm operation, successive read cycles to any address cause Q6 to toggle. The system may use either  $\overline{OE}$  or  $\overline{CE}$  to control the read cycles. When the operation is complete, Q6 stops toggling.

After an erase command sequence is written, if all sectors selected for erasing are protected, Q6 toggles and returns to reading array data. If not all selected sectors are protected, the Automatic Erase algorithm erases the unprotected sectors, and ignores the selected sectors that are protected.

The system can use Q6 and Q2 together to determine whether a sector is actively erasing or is erase suspended. When the device is actively erasing (that is, the Automatic Erase algorithm is in progress), Q6 toggling. When the device enters the Erase Suspend mode, Q6 stops toggling. However, the system must also use Q2 to determine which sectors are erasing or erase-suspended. Alternatively, the system can use Q7.

If a program address falls within a protected sector, Q6 toggles for approximately 2 us after the program command sequence is written, then returns to reading array data.

Q6 also toggles during the erase-suspend-program mode, and stops toggling once the Automatic Program algorithm is complete.

Table 4 shows the outputs for Toggle Bit I on Q6.

### **Q2:Toggle Bit II**

The "Toggle Bit II" on Q2, when used with Q6, indicates whether a particular sector is actively erasing (that is, the Automatic Erase algorithm is in process), or whether that sector is erase-suspended. Toggle Bit I is valid after the rising edge of the final  $\overline{WE}$  or  $\overline{CE}$ , whichever happens first, pulse in the command sequence.

Q2 toggles when the system reads at addresses within those sectors that have been selected for erasure. (The system may use either  $\overline{OE}$  or  $\overline{CE}$  to control the read cycles.) But Q2 cannot distinguish whether the sector is actively erasing or is erase-suspended. Q6, by comparison, indicates whether the device is actively erasing, or is in Erase Suspend, but cannot distinguish which sectors are selected for erasure. Thus, both status bits are required for sectors and mode information. Refer to Table 4 to compare outputs for Q2 and Q6.

### **Reading Toggle Bits Q6/ Q2**

Whenever the system initially begins reading toggle bit status, it must read Q7-Q0 at least twice in a row to determine whether a toggle bit is toggling. Typically, the system would note and store the value of the toggle bit after the first read. After the second read, the system would compare the new value of the toggle bit with the first. If the toggle bit is not toggling, the device has completed the program or erase operation. The system can read array data on Q7-Q0 on the following read cycle.

However, if after the initial two read cycles, the system determines that the toggle bit is still toggling, the system also should note whether the value of Q5 is high (see the section on Q5). If it is, the system should then determine again whether the toggle bit is toggling, since the toggle bit may have stopped toggling just as Q5 went high. If the toggle bit is no longer toggling, the device has successfully completed the program or erase operation. If it is still toggling, the device did not complete the operation successfully, and the system must write the reset command to return to reading array data.

The remaining scenario is that system initially determines that the toggle bit is toggling and Q5 has not gone high. The system may continue to monitor the toggle bit and Q5 through successive read cycles, determining the status as described in the previous paragraph. Alternatively, it may choose to perform other system tasks. In this case, the system must start at the beginning of the algorithm when it returns to determine the status of the operation.

## Q5 Exceeded Timing Limits

Q5 will indicate if the program or erase time has exceeded the specified limits (internal pulse count). Under these conditions Q5 will produce a "1". This time-out condition indicates that the program or erase cycle was not successfully completed.  $\overline{\text{Data}}$  Polling and Toggle Bit are the only operating functions of the device under this condition.

If this time-out condition occurs during sector erase operation, it specifies that a particular sector is bad and it may not be reused. However, other sectors are still functional and may be used for the program or erase operation. The device must be reset to use other sectors. Write the Reset command sequence to the device, and then execute program or erase command sequence. This allows the system to continue to use the other active sectors in the device.

If this time-out condition occurs during the chip erase operation, it specifies that the entire chip is bad or combination of sectors are bad.

If this time-out condition occurs during the byte programming operation, it specifies that the entire sector containing that byte is bad and this sector may not be reused, (other sectors are still functional and can be reused).

The time-out condition may also appear if a user tries to program a non blank location without erasing. In this case the device locks out and never completes the Automatic Algorithm operation. Hence, the system never reads a valid data on Q7 bit and Q6 never stops toggling. Once the Device has exceeded timing limits, the Q5 bit will indicate a "1". Please note that this is not a device failure condition since the device was incorrectly used.

## DATA PROTECTION

The MX29F400T/B is designed to offer protection against accidental erasure or programming caused by spurious system level signals that may exist during power transition. During power up the device automatically resets the state machine in the Read mode. In addition, with its control register architecture, alteration of the memory contents only occurs after successful completion of specific command sequences. The device also incorporates several features to prevent inadvertent write cycles

resulting from VCC power-up and power-down transition or system noise.

## TEMPORARY SECTOR UNPROTECT

This feature allows temporary unprotection of previously protected sector to change data in-system. The Temporary Sector Unprotect mode is activated by setting the  $\overline{\text{RESET}}$  pin to VID(11.5V-12.5V). During this mode, formerly protected sectors can be programmed or erased as un-protected sector. Once VID is remove from the  $\overline{\text{RESET}}$  pin, all the previously protected sectors are protected again.

## Q3 Sector Erase Timer

After the completion of the initial sector erase command sequence, the sector erase time-out will begin. Q3 will remain low until the time-out is complete.  $\overline{\text{Data}}$  Polling and Toggle Bit are valid after the initial sector erase command sequence.

If  $\overline{\text{Data}}$  Polling or the Toggle Bit indicates the device has been written with a valid erase command, Q3 may be used to determine if the sector erase timer window is still open. If Q3 is high ("1") the internally controlled erase cycle has begun; attempts to write subsequent commands to the device will be ignored until the erase operation is completed as indicated by  $\overline{\text{Data}}$  Polling or Toggle Bit. If Q3 is low ("0"), the device will accept additional sector erase commands. To insure the command has been accepted, the system software should check the status of Q3 prior to and following each subsequent sector erase command. If Q3 were high on the second status check, the command may not have been accepted.

## WRITE PULSE "GLITCH" PROTECTION

Noise pulses of less than 5ns(typical) on  $\overline{\text{CE}}$  or  $\overline{\text{WE}}$  will not initiate a write cycle.

## LOGICAL INHIBIT

Writing is inhibited by holding any one of  $\overline{\text{OE}} = \text{VIL}$ ,  $\overline{\text{CE}} = \text{VIH}$  or  $\overline{\text{WE}} = \text{VIH}$ . To initiate a write cycle  $\overline{\text{CE}}$  and  $\overline{\text{WE}}$  must be a logical zero while  $\overline{\text{OE}}$  is a logical one.

## POWER SUPPLY DECOUPLING

In order to reduce power switching effect, each device should have a 0.1uF ceramic capacitor connected between its VCC and GND.

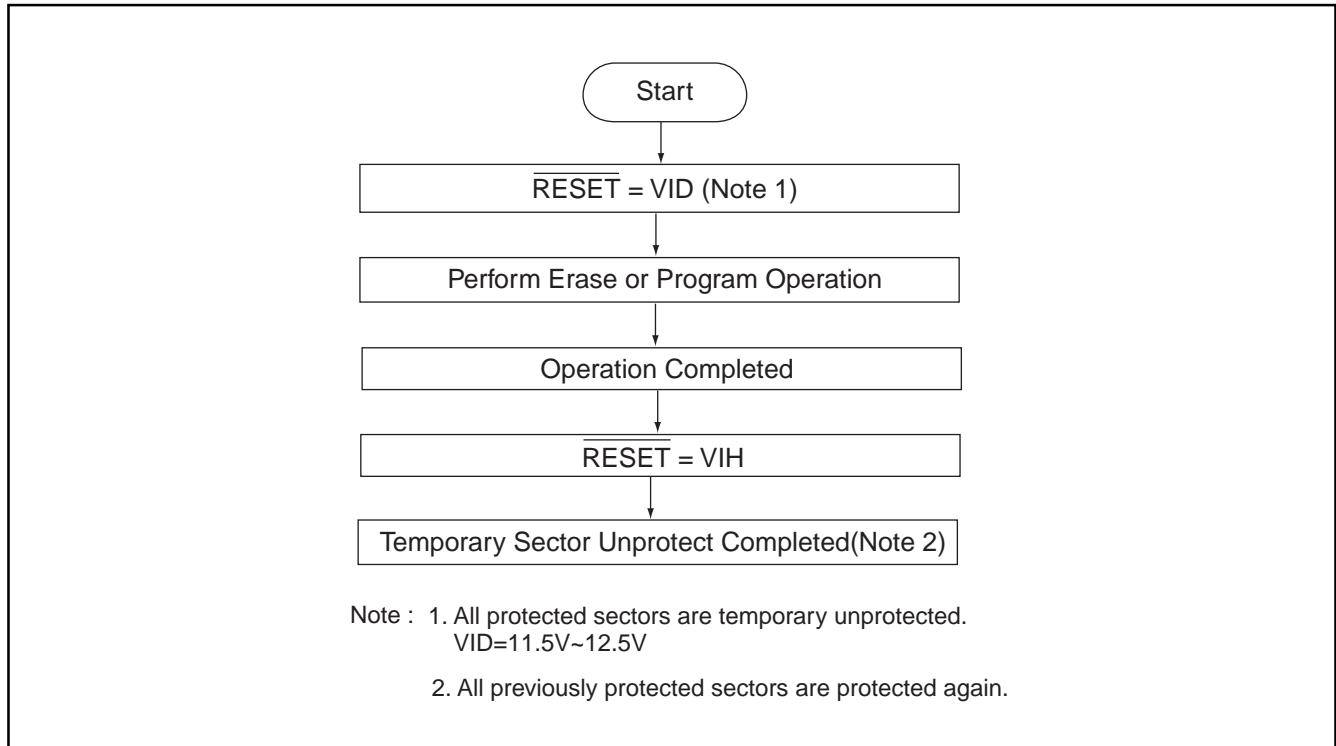
**Temporary Sector Unprotect Operation**

**TEMPORARY SECTOR UNPROTECT**

Parameter Std.	Description	Test Setup	AllSpeed Options	Unit
tVIDR	VID Rise and Fall Time (See Note)	Min	500	ns
tRSP	RESET Setup Time for Temporary Sector Unprotect	Min	4	us

Note:  
Not 100% tested

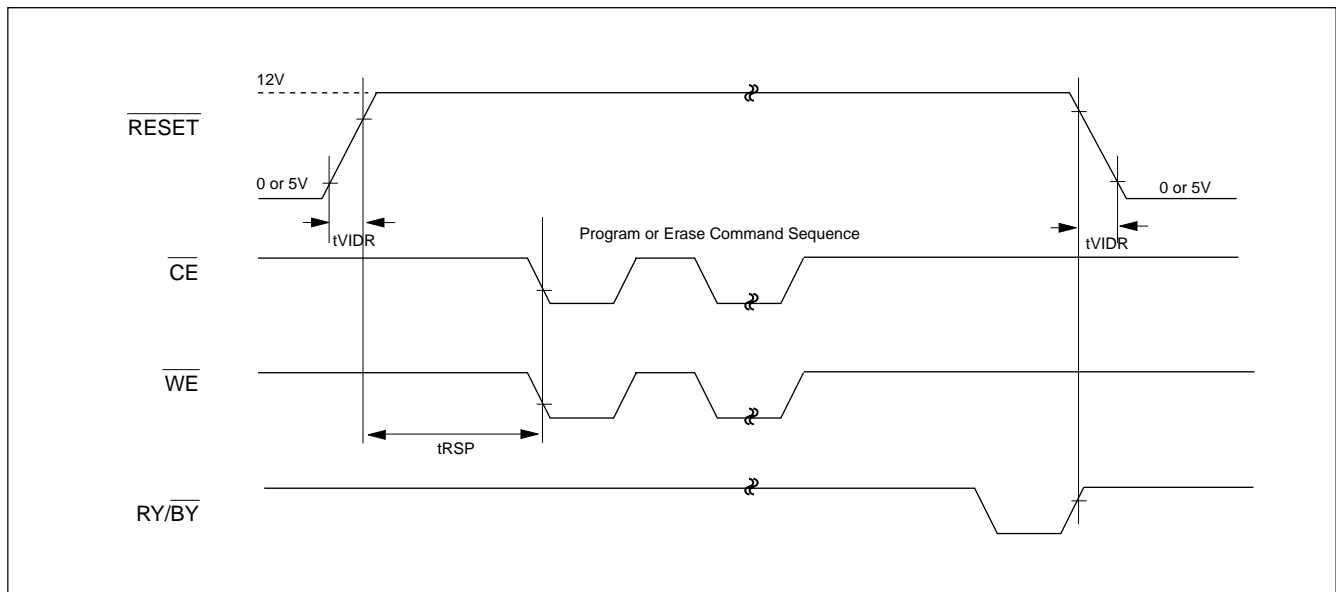
**Temporary Sector Unprotect Timing Diagram**

**AC CHARACTERISTICS**

Parameter Std	Description	Test Setup	All Speed Options	Unit
tREADY1	$\overline{\text{RESET}}$ PIN Low (During Automatic Algorithms) to Read or Write (See Note)	MAX	20	us
tREADY2	$\overline{\text{RESET}}$ PIN Low (NOT During Automatic Algorithms) to Read or Write (See Note)	MAX	500	ns
tRP1	$\overline{\text{RESET}}$ Pulse Width (During Automatic Algorithms)	MIN	10	us
tRP2	$\overline{\text{RESET}}$ Pulse Width (NOT During Automatic Algorithms)	MIN	500	ns
tRH	$\overline{\text{RESET}}$ High Time Before Read(See Note)	MIN	0	ns
tRB1	RY/ $\overline{\text{BY}}$ Recovery Time(to $\overline{\text{CE}}$ , $\overline{\text{OE}}$ go low)	MIN	0	ns
tRB2	RY/ $\overline{\text{BY}}$ Recovery Time(to $\overline{\text{WE}}$ go low)	MIN	50	ns

Note:Not 100% tested

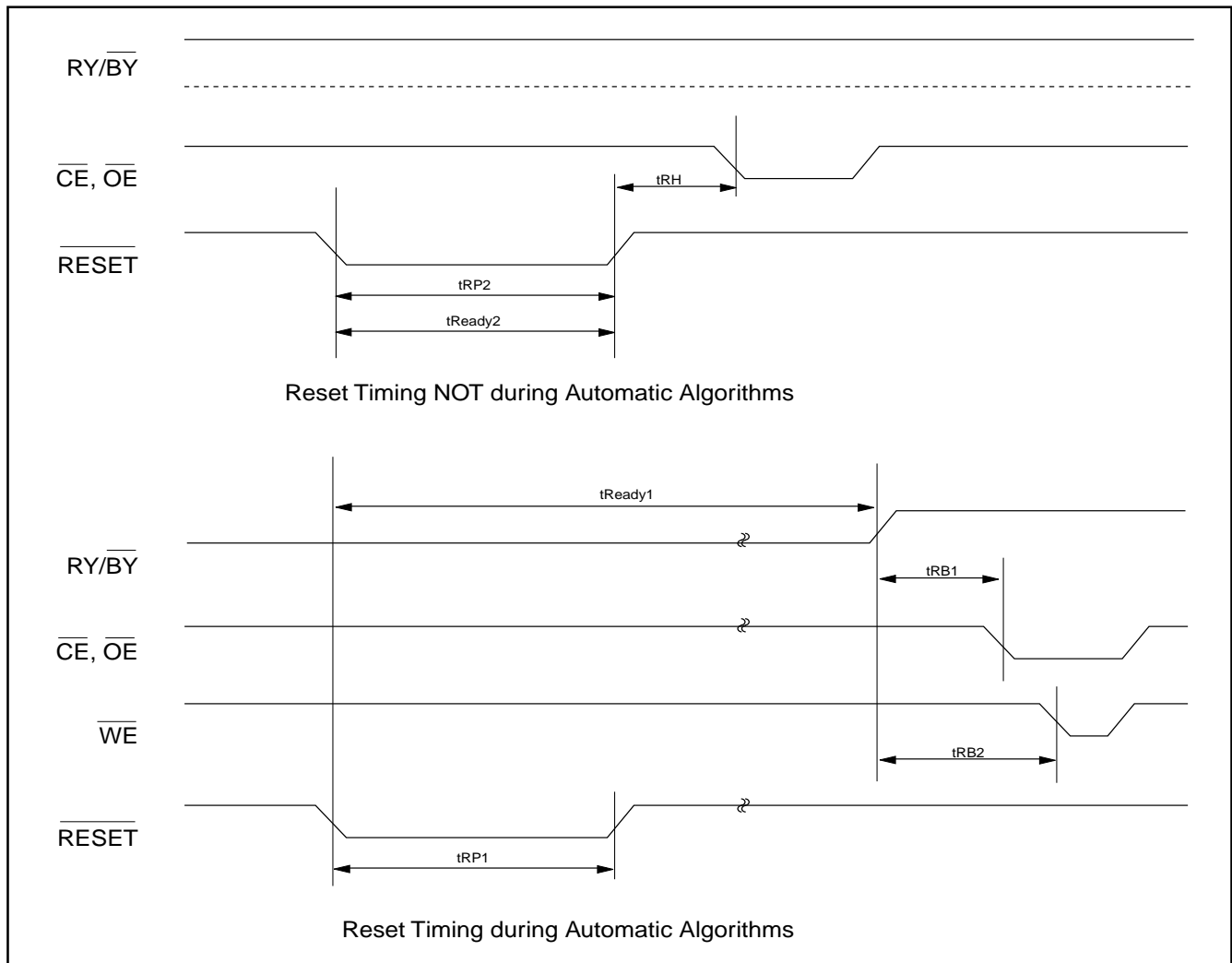
**RESET TIMING WAVEFORM**

## SECTOR PROTECTION WITH 12V SYSTEM

The MX29F400T/B features hardware sector protection. This feature will disable both program and erase operations for these sectors protected. To activate this mode, the programming equipment must force VID on address pin A9 and control pin  $\overline{OE}$ , (suggest VID = 12V) A6 = VIL and  $\overline{CE} = VIL$ .(see Table 2) Programming of the protection circuitry begins on the falling edge of the  $\overline{WE}$  pulse and is terminated on the rising edge. Please refer to sector protect algorithm and waveform.

To verify programming of the protection circuitry, the programming equipment must force VID on address pin A9 (with  $\overline{CE}$  and  $\overline{OE}$  at VIL and  $\overline{WE}$  at VIH). When A1=1, it will produce a logical "1" code at device output Q0 for a protected sector. Otherwise the device will produce 00H for the unprotected sector. In this mode, the addresses, except for A1, are don't care. Address locations with A1 = VIL are reserved to read manufacturer and device codes.(Read Silicon ID)

It is also possible to determine if the sector is protected in the system by writing a Read Silicon ID command. Performing a read operation with A1=VIH, it will produce a logical "1" at Q0 for the protected sector.

## CHIP UNPROTECT WITH 12V SYSTEM

The MX29F400T/B also features the chip unprotect mode, so that all sectors are unprotected after chip unprotect is completed to incorporate any changes in the code. It is recommended to protect all sectors before activating chip unprotect mode.

To activate this mode, the programming equipment must force VID on control pin  $\overline{OE}$  and address pin A9. The  $\overline{CE}$  pins must be set at VIL. Pins A6 must be set to VIH.(see Table 2) Refer to chip unprotect algorithm and waveform for the chip unprotect algorithm. The unprotection mechanism begins on the falling edge of the  $\overline{WE}$  pulse and is terminated on the rising edge.

It is also possible to determine if the chip is unprotected in the system by writing the Read Silicon ID command. Performing a read operation with A1=VIH, it will produce 00H at data outputs(Q0-Q7) for an unprotected sector. It is noted that all sectors are unprotected after the chip unprotect algorithm is completed.

## POWER-UP SEQUENCE

The MX29F400T/B powers up in the Read only mode. In addition, the memory contents may only be altered after successful completion of the predefined command sequences.

## SECTOR PROTECTION WITHOUT 12V SYSTEM

The MX29F400T/B also feature a hardware sector protection method in a system without 12V power supply. The programming equipment do not need to supply 12 volts to protect sectors. The details are shown in sector protect algorithm and waveform.

## CHIP UNPROTECT WITHOUT 12V SYSTEM

The MX29F400T/B also feature a hardware chip unprotection method in a system without 12V power supply. The programming equipment do not need to supply 12 volts to unprotect all sectors. The details are shown in chip unprotect algorithm and waveform.

## ABSOLUTE MAXIMUM RATINGS

RATING	VALUE
Ambient Operating Temperature	-40°C to 125°C
Ambient Temperature with Power Applied	-55°C to 125°C
Storage Temperature	-65°C to 125°C
Applied Input Voltage	-0.5V to 7.0V
Applied Output Voltage	-0.5V to 7.0V
VCC to Ground Potential	-0.5V to 7.0V
A9 & $\overline{OE}$	-0.5V to 13.5V

### NOTICE:

Stresses greater than those listed under ABSOLUTE MAXIMUM RATINGS may cause permanent damage to the device. This is a stress rating only and functional operational sections of this specification is not implied. Exposure to absolute maximum rating conditions for extended period may affect reliability.

### NOTICE:

Specifications contained within the following tables are subject to change.



**CAPACITANCE TA = 25°C, f = 1.0 MHz**

SYMBOL	PARAMETER	MIN.	TYP	MAX.	UNIT	CONDITIONS
CIN1	Input Capacitance			8	pF	VIN = 0V
CIN2	Control Pin Capacitance			12	pF	VIN = 0V
COUT	Output Capacitance			12	pF	VOUT = 0V

**READ OPERATION****DC CHARACTERISTICS TA = 0°C to 70°C, -40°C to 125°C, VCC = 5V ±10%**

SYMBOL	PARAMETER	MIN.	TYP	MAX.	UNIT	CONDITIONS
ILI	Input Leakage Current			1	uA	VIN = GND to VCC
ILO	Output Leakage Current			10	uA	VOUT = GND to VCC
ISB1	Standby VCC current			1	mA	CE = VIH
ISB2			1(Note3)	5(Note3)	uA	$\overline{CE} = VCC \pm 0.3V$
ICC1	Operating VCC current			40	mA	IOUT = 0mA, f=5MHz
ICC2				50	mA	IOUT= 0mA, f=10MHz
VIL	Input Low Voltage	-0.3(NOTE 1)		0.8	V	
VIH	Input High Voltage(NOTE 2)	2.0		VCC + 0.3	V	
VOL	Output Low Voltage			0.45	V	IOL = 2.1mA
VOH1	Output High Voltage(TTL)	2.4			V	IOH = -2mA
VOH2	Output High Voltage(CMOS)	VCC-0.4			V	IOH = -100uA, VCC=VCC MIN

**NOTES:**

1. VIL min. = -1.0V for pulse width is equal to or less than 50 ns.  
VIL min. = -2.0V for pulse width is equal to or less than 20 ns.
2. VIH max. = VCC + 1.5V for pulse width is equal to or less than 20 ns  
If VIH is over the specified maximum value, read operation cannot be guaranteed.
3. ISB2 20uA max. for Automotive grade.

**AC CHARACTERISTICS TA = 0°C to 70°C, -40°C to 125°C, VCC = 5V ± 10%**

SYMBOL	PARAMETER	29F400T/B-55 (Note2)		29F400T/B-70		UNIT	Conditions
		MIN.	MAX.	MIN.	MAX.		
tACC	Address to Output Delay		55		70	ns	$\overline{CE}=\overline{OE}=VIL$
tCE	$\overline{CE}$ to Output Delay		55		70	ns	$\overline{OE}=VIL$
tOE	$\overline{OE}$ to Output Delay		15		40	ns	$\overline{CE}=VIL$
tDF	$\overline{OE}$ High to Output Float (Note1)	0	20	0	30	ns	$\overline{CE}=VIL$
tOH	Address to Output hold	0		0		ns	$\overline{CE}=\overline{OE}=VIL$

SYMBOL	PARAMETER	29F400T/B-90 (Note3)		29F400T/B-12(Note3)		UNIT	Conditions
		MIN.	MAX.	MIN.	MAX.		
tACC	Address to Output Delay		90		120	ns	$\overline{CE}=\overline{OE}=VIL$
tCE	$\overline{CE}$ to Output Delay		90		120	ns	$\overline{OE}=VIL$
tOE	$\overline{OE}$ to Output Delay		40		50	ns	$\overline{CE}=VIL$
tDF	$\overline{OE}$ High to Output Float (Note1)	0	30	0	30	ns	$\overline{CE}=VIL$
tOH	Address to Output hold		0		0	ns	$\overline{CE}=\overline{OE}=VIL$

**TEST CONDITIONS:**

- Input pulse levels: 0.45V/2.4V
- Input rise and fall times is equal to or less than 10ns
- Output load: 1 TTL gate + 100pF (Including scope and jig)
- Reference levels for measuring timing: 0.8V, 2.0V

**NOTE:**

1. tDF is defined as the time at which the output achieves the open circuit condition and data is no longer driven.
2. VCC=5V±10%, CL=50pF, VIH/VIL=3.0V/0V, VOH/VOL=1.5V/1.5V, IOL=2mA, IOH=-2mA.
3. Automotive grade is only provided for MX29F400T/B-90 & MX29F400T/B-12

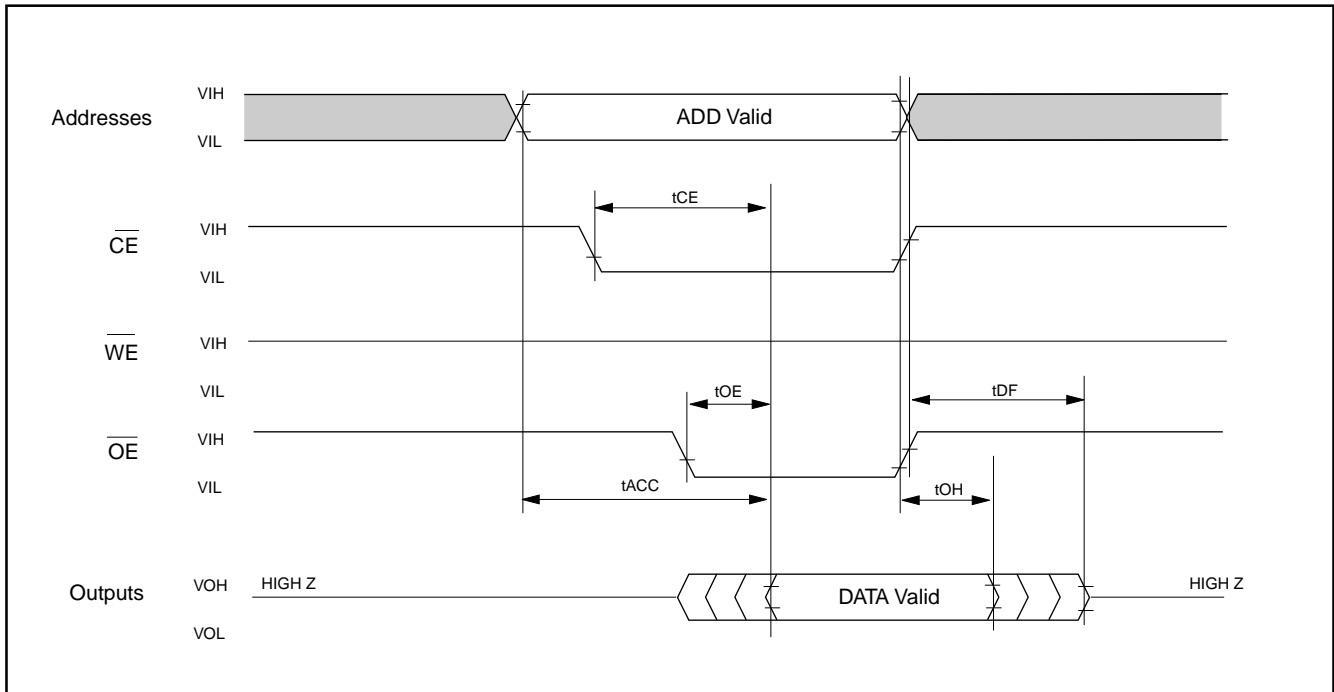
**READ TIMING WAVEFORMS**

**COMMAND PROGRAMMING/DATA PROGRAMMING/ERASE OPERATION**
**DC CHARACTERISTICS  $T_A = 0^\circ\text{C}$  to  $70^\circ\text{C}$ ,  $-40^\circ\text{C}$  to  $125^\circ\text{C}$ ,  $V_{CC} = 5V \pm 10\%$** 

SYMBOL	PARAMETER	MIN.	TYP	MAX.	UNIT	CONDITIONS
ICC1 (Read)	Operating VCC Current			40	mA	IOUT=0mA, f=5MHz
ICC2				50	mA	IOUT=0mA, F=10MHz
ICC3 (Program)				50	mA	In Programming
ICC4 (Erase)				50	mA	In Erase
ICCES	VCC Erase Suspend Current		2		mA	$\overline{CE}=V_{IH}$ , Erase Suspended

**NOTES:**

1. VIL min. = -0.6V for pulse width is equal to or less than 20ns.
2. If VIH is over the specified maximum value, programming operation cannot be guaranteed.
3. ICCES is specified with the device de-selected. If the device is read during erase suspend mode, current draw is the sum of ICCES and ICC1 or ICC2.
4. All current are in RMS unless otherwise noted.



## AC CHARACTERISTICS TA = 0°C to 70°C, VCC = 5V ± 10%

Symbol	PARAMETER	29F400T/B-55(Note2)		29F400T/B-70		Unit
		MIN.	MAX.	MIN.	MAX.	
tOES	$\overline{OE}$ setup time	50		50		ns
tCWC	Command programming cycle	70		70		ns
tCEP	$\overline{WE}$ programming pulse width	45		45		ns
tCEPH1	$\overline{WE}$ programming pulse width High	20		20		ns
tCEPH2	$\overline{WE}$ programming pulse width High	20		20		ns
tAS	Address setup time	0		0		ns
tAH	Address hold time	45		45		ns
tDS	Data setup time	30		30		ns
tDH	Data hold time	0		0		ns
tCESC	$\overline{CE}$ setup time before command write	0		0		ns
tDF	Output disable time (Note 1)		20		30	ns
tAETC	Total erase time in auto chip erase	4(TYP.)	32	4(TYP.)	32	s
tAETB	Total erase time in auto sector erase	1.3(TYP.)	10.4	1.3(TYP.)	10.4	s
tAVT	Total programming time in auto verify (byte/ word program time)	7/12(TYP.)	210/360	7/12(TYP.)	210/360	us
tBAL	Sector address load time	100		100		us
tCH	$\overline{CE}$ Hold Time	0		0		ns
tCS	$\overline{CE}$ setup to $\overline{WE}$ going low	0		0		ns
tVLHT	Voltage Transition Time	4		4		us
tOESP	$\overline{OE}$ Setup Time to $\overline{WE}$ Active	4		4		us
tWPP1	Write pulse width for sector protect	10		10		us
tWPP2	Write pulse width for sector unprotect	12		12		ms

### NOTES:

1. tDF defined as the time at which the output achieves the open circuit condition and data is no longer driven.
2. Under condition of VCC=5V±10%, CL=50pF, VIH/VIL=3.0V/0V, VOH/VOL=1.5V/1.5V, IOL=2mA, IOH=-2mA.



## AC CHARACTERISTICS TA = 0°C to 70°C, -40°C to 125°C, VCC = 5V ± 10%

Symbol	PARAMETER	29F400T/B-90		29F400T/B-120		Unit
		MIN.	MAX.	MIN.	MAX.	
tOES	$\overline{OE}$ setup time	50		50		ns
tCWC	Command programming cycle	90		120		ns
tCEP	$\overline{WE}$ programming pulse width	45		45		ns
tCEPH1	$\overline{WE}$ programming pluse width High	20		20		ns
tCEPH2	$\overline{WE}$ programming pluse width High	20		20		ns
tAS	Address setup time	0		0		ns
tAH	Address hold time	45		50		ns
tDS	Data setup time	45		50		ns
tDH	Data hold time	0		0		ns
tCESC	$\overline{CE}$ setup time before command write	0		0		ns
tDF	Output disable time (Note 1)		30		30	ns
tAETC	Total erase time in auto chip erase	4(TYP.)	32	4(TYP.)	32	s
tAETB	Total erase time in auto sector erase	1.3(TYP.)	10.4	1.3(TYP.)	10.4	s
tAVT	Total programming time in auto verify (byte/ word program time)	7/12(TYP.)	210/360	7/12(TYP.)	210/360	us
tBAL	Sector address load time	100		100		us
tCH	$\overline{CE}$ Hold Time	0		0		ns
tCS	$\overline{CE}$ setup to $\overline{WE}$ going low	0		0		ns
tVLHT	Voltge Transition Time	4		4		us
tOESP	$\overline{OE}$ Setup Time to $\overline{WE}$ Active	4		4		us
tWPP1	Write pulse width for sector protect	10		10		us
tWPP2	Write pulse width for sector unprotect	12		12		ms

### NOTES:

1. tDF defined as the time at which the output achieves the open circuit condition and data is no longer driven.
2. Under condition of VCC=5V± 10%, CL=50pF, VIH/VIL=3.0V/0V, VOH/VOL=1.5V/1.5V, IOL=2mA, IOH=-2mA.

## SWITCHING TEST CIRCUITS

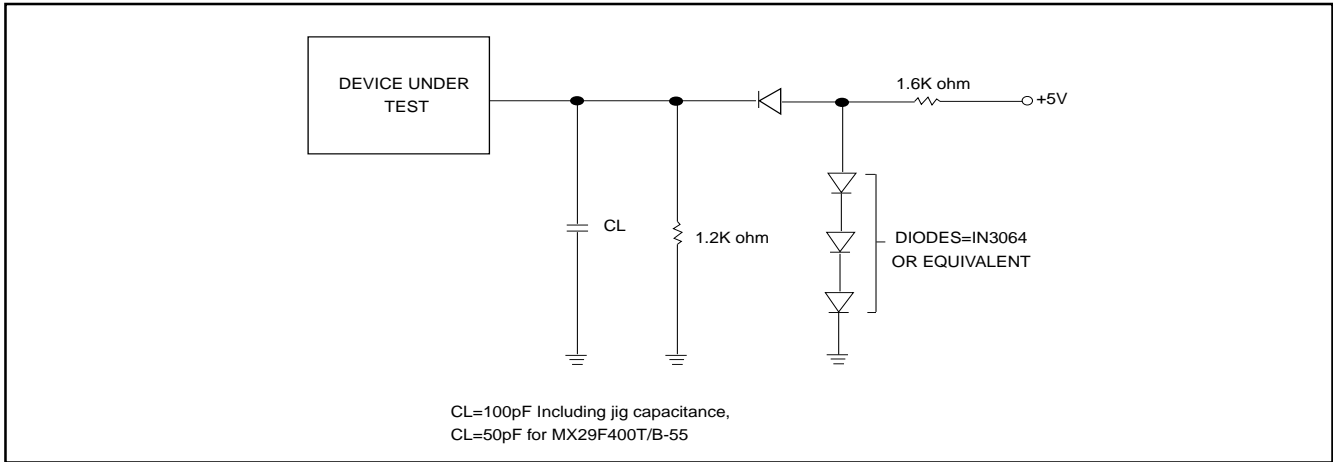

## SWITCHING TEST WAVEFORMS

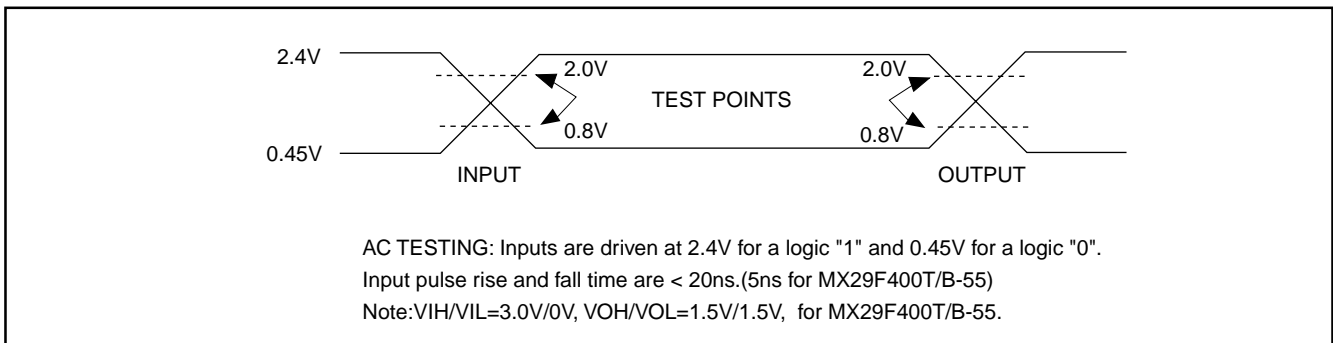

## COMMAND WRITE TIMING WAVEFORM

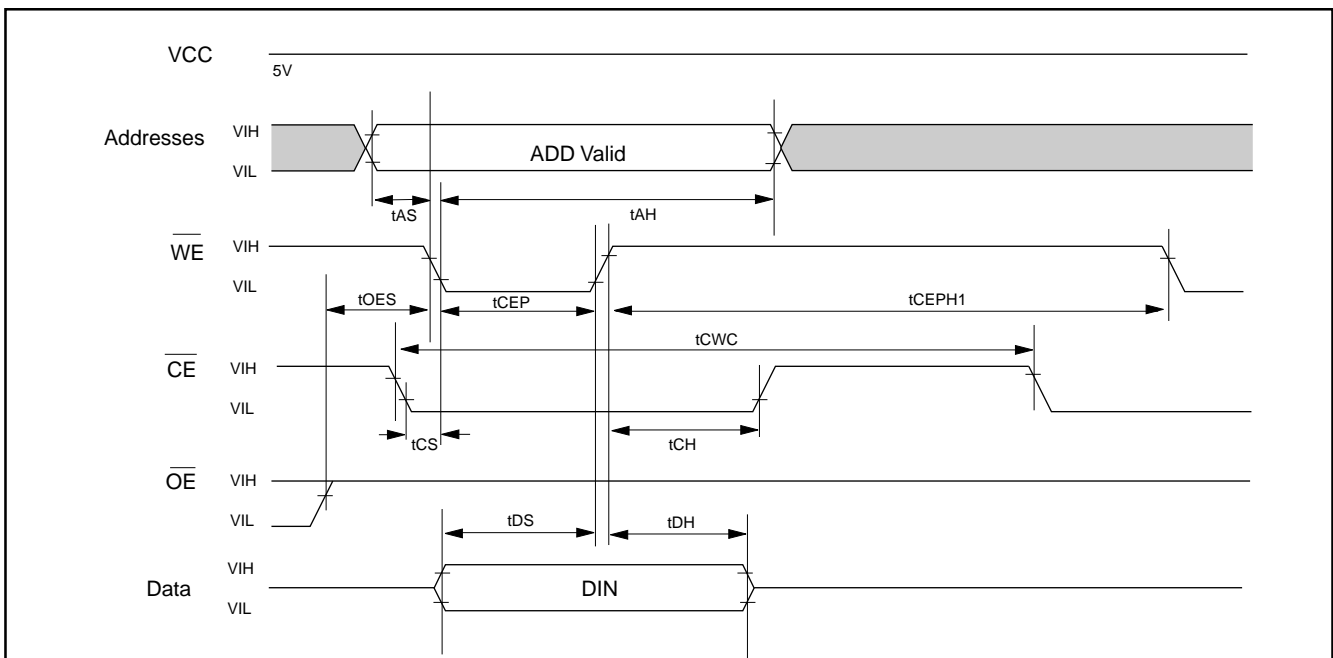

### AUTOMATIC PROGRAMMING TIMING WAVEFORM

One byte data is programmed. Verify in fast algorithm and additional programming by external control are not required because these operations are executed automatically by internal control circuit. Programming completion can be verified by DATA polling and toggle

bit checking after automatic verification starts. Device outputs DATA during programming and DATA after programming on Q7.(Q6 is for toggle bit; see toggle bit, DATA polling, timing waveform)

### AUTOMATIC PROGRAMMING TIMING WAVEFORM (WORD MODE)

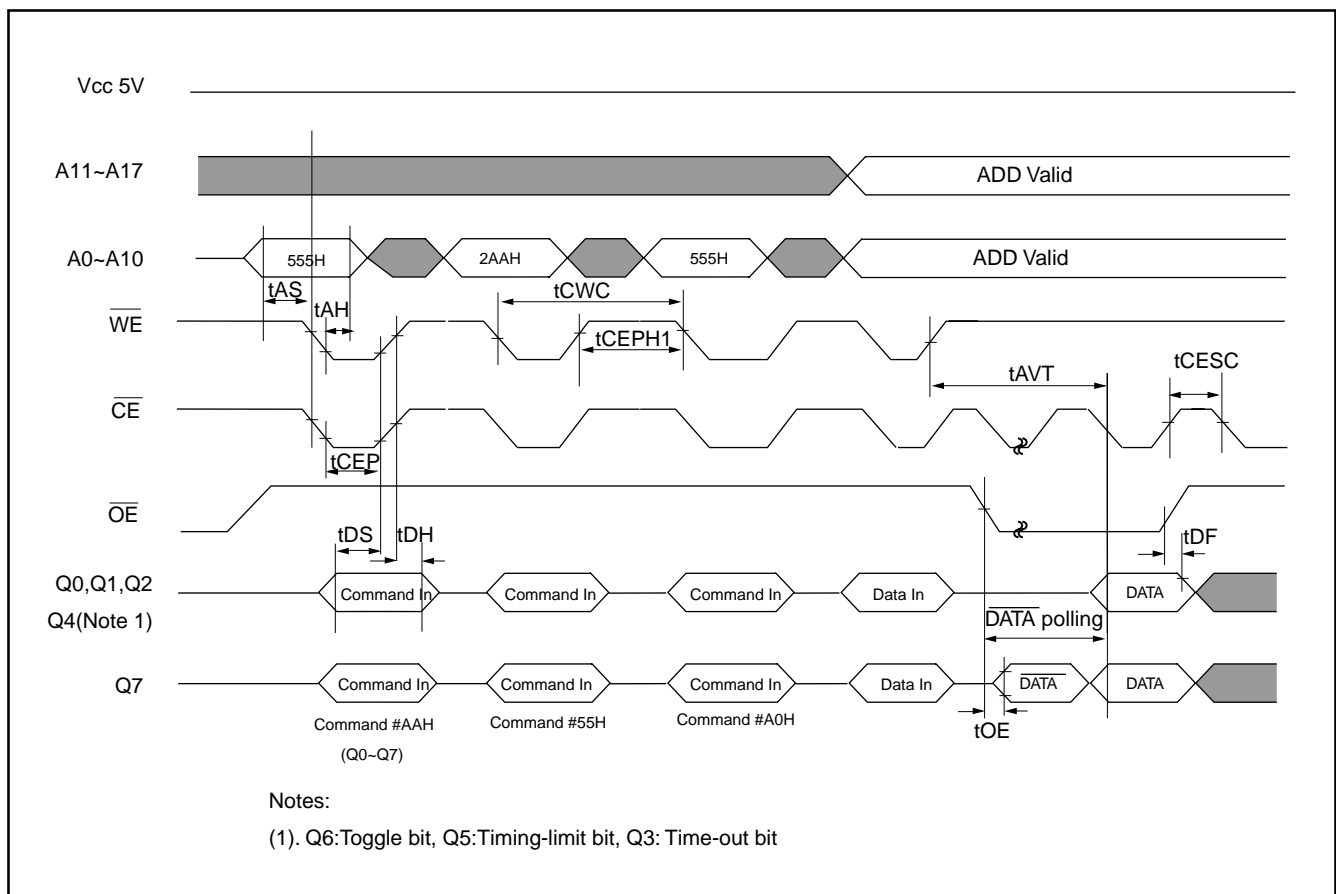

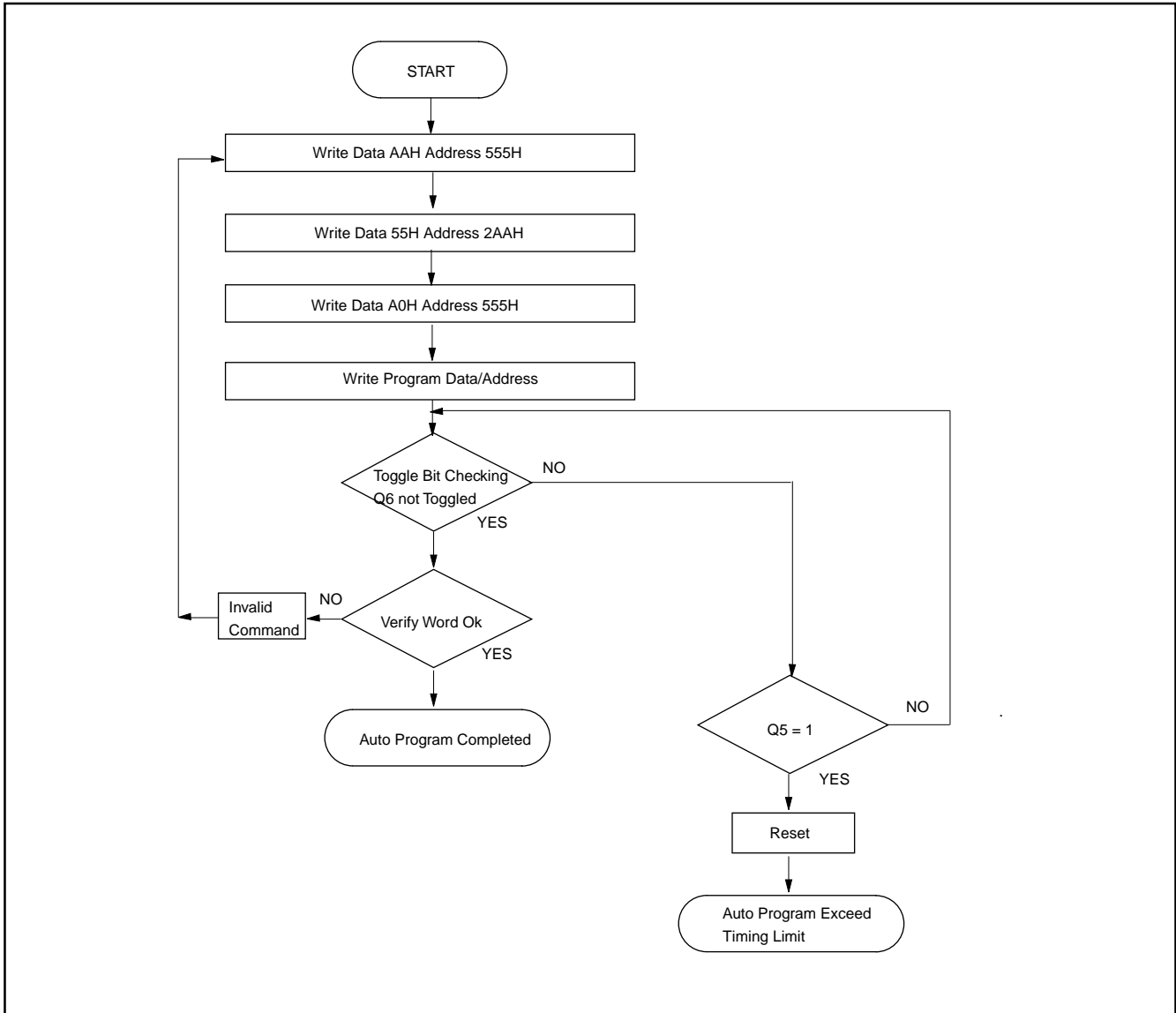
**AUTOMATIC PROGRAMMING ALGORITHM FLOWCHART (WORD MODE)**



## AUTOMATIC CHIP ERASE TIMING WAVEFORM

All data in chip are erased. External erase verification is not required because data is erased automatically by internal control circuit. Erasure completion can be verified by DATA polling and toggle bit checking after auto-

matic erase starts. Device outputs 0 during erasure and 1 after erasure on Q7. (Q6 is for toggle bit; see toggle bit, DATA polling, timing waveform)

## AUTOMATIC CHIP ERASE TIMING WAVEFORM (WORD MODE)

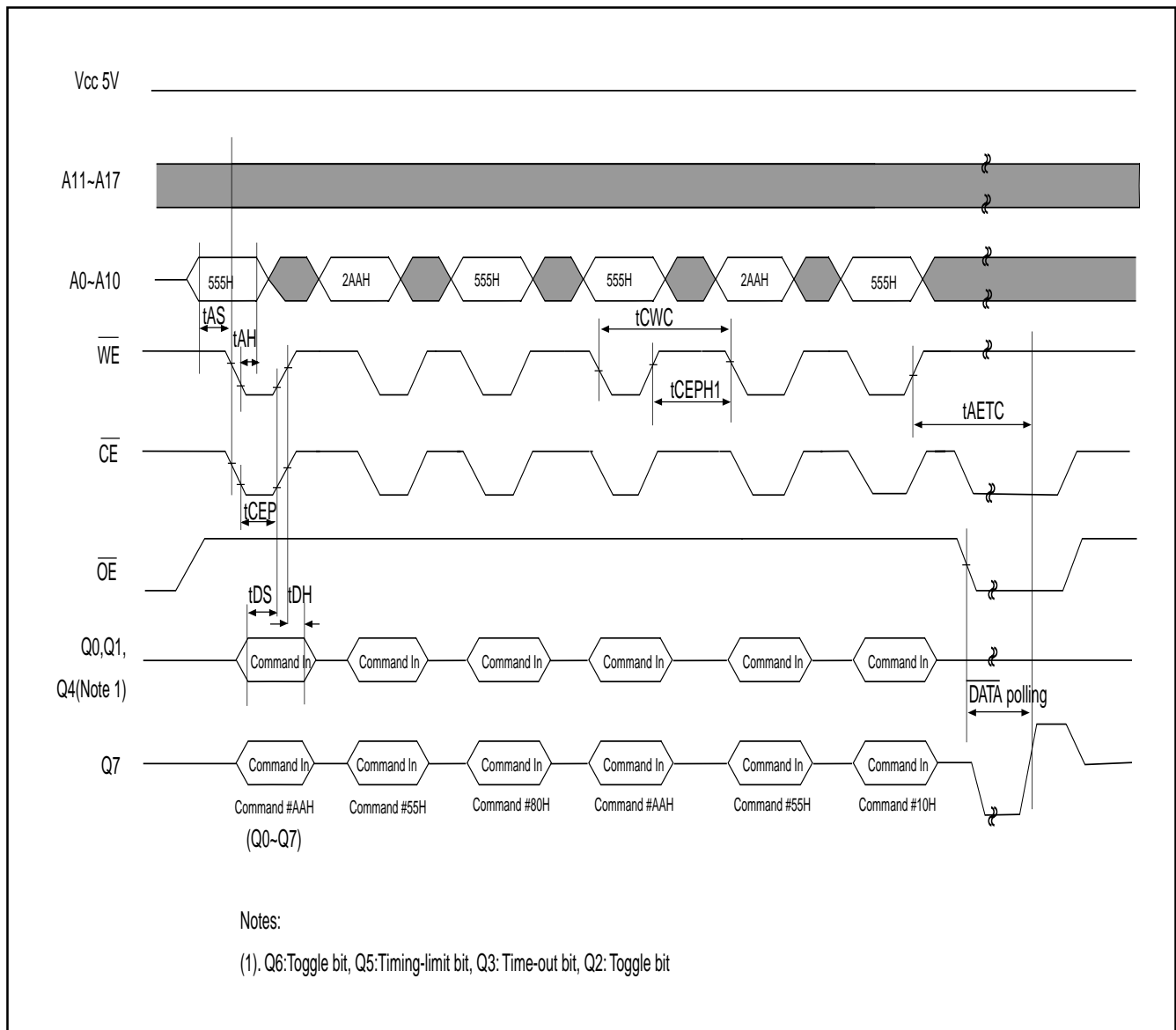

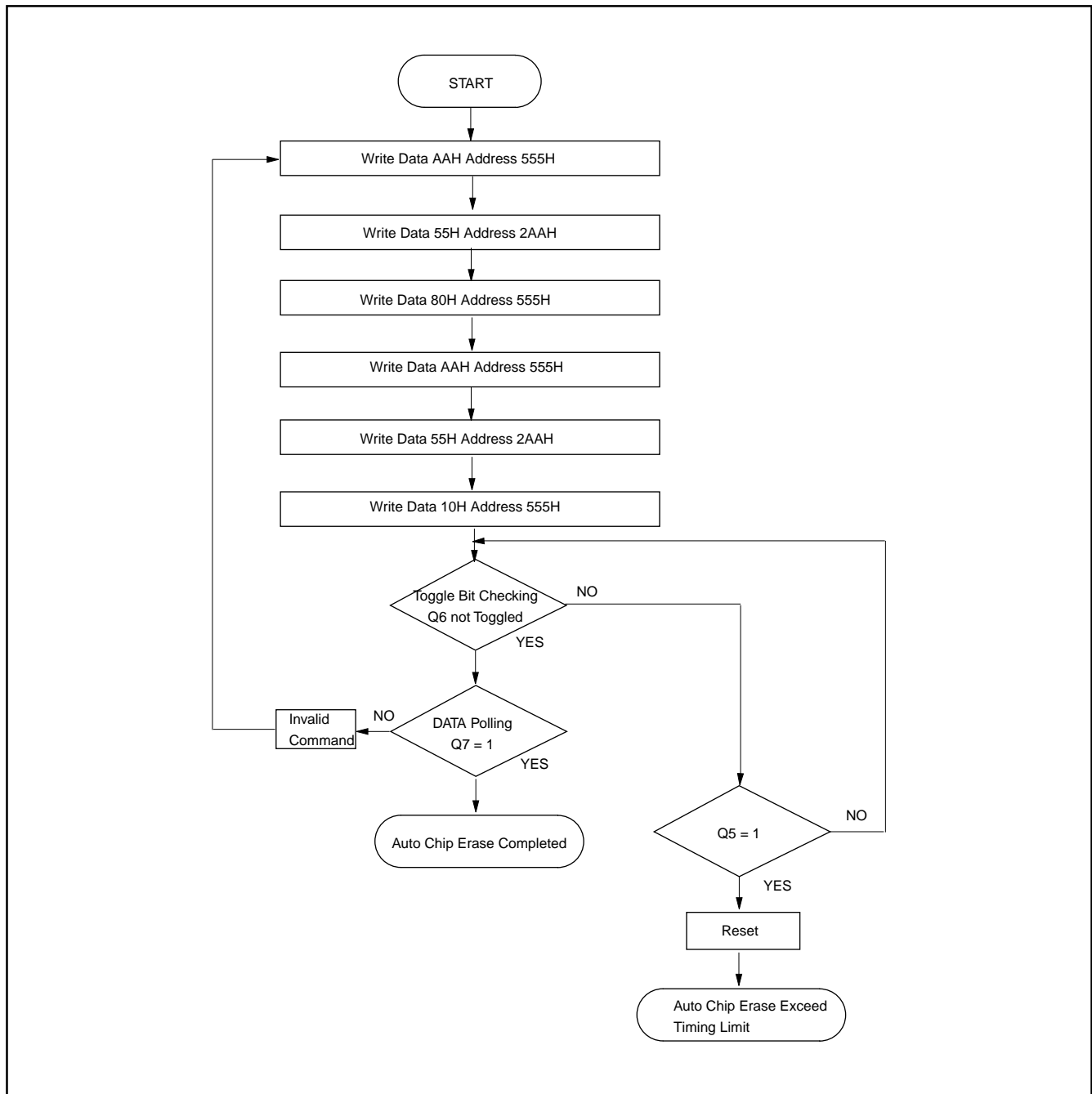
**AUTOMATIC CHIP ERASE ALGORITHM FLOWCHART (WORD MODE)**

**AUTOMATIC SECTOR ERASE TIMING WAVEFORM**

Sector data indicated by A12 to A17 are erased. External erase verify is not required because data are erased automatically by internal control circuit. Erasure completion can be verified by  $\overline{\text{DATA}}$  polling and toggle bit check-

ing after automatic erase starts. Device outputs 0 during erasure and 1 after erasure on Q7. (Q6 is for toggle bit; see toggle bit,  $\overline{\text{DATA}}$  polling, timing waveform)

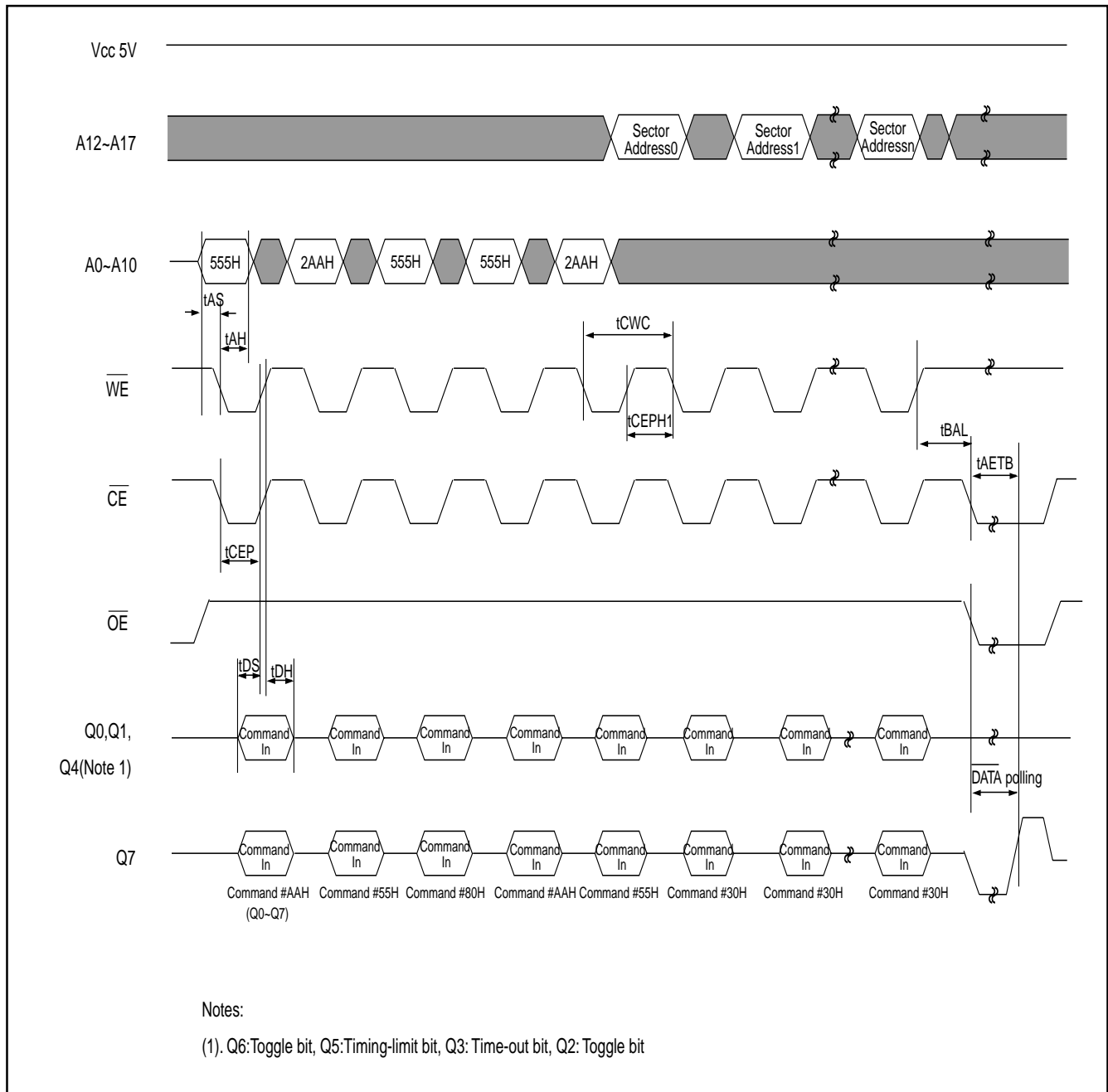
**AUTOMATIC SECTOR ERASE TIMING WAVEFORM (WORD MODE)**

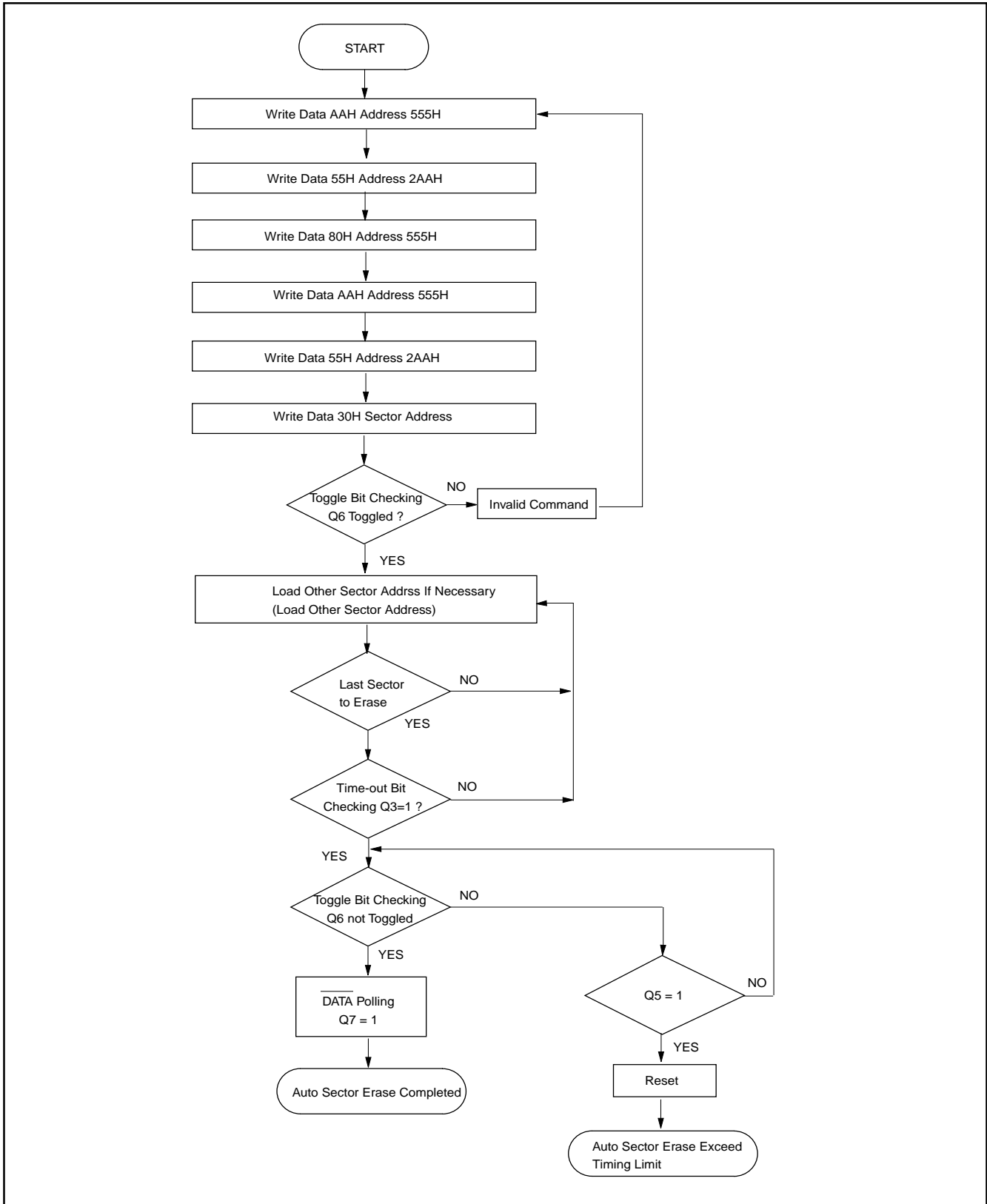
**AUTOMATIC SECTOR ERASE ALGORITHM FLOWCHART (WORD MODE)**

ERASE SUSPEND/ERASE RESUME FLOWCHART

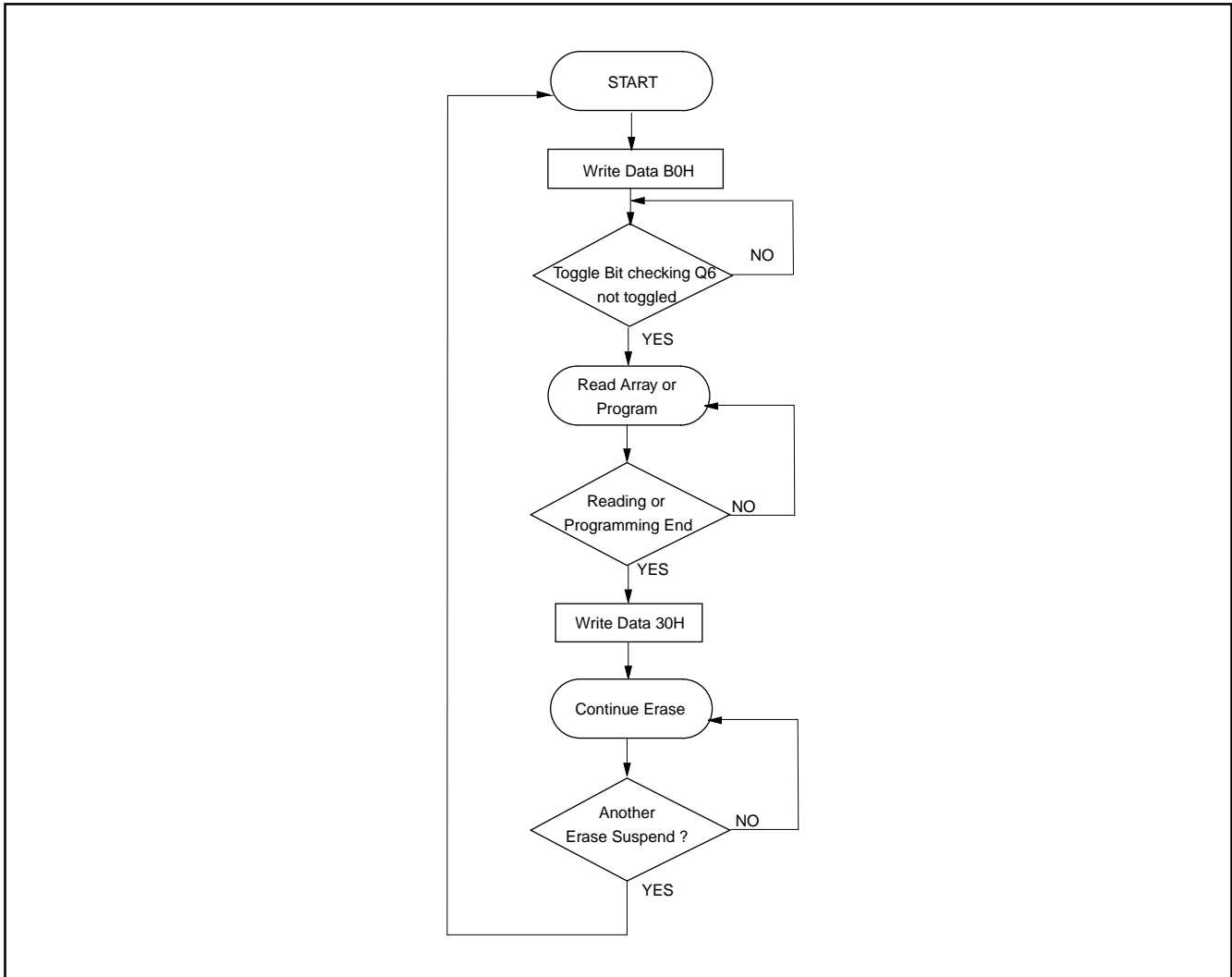

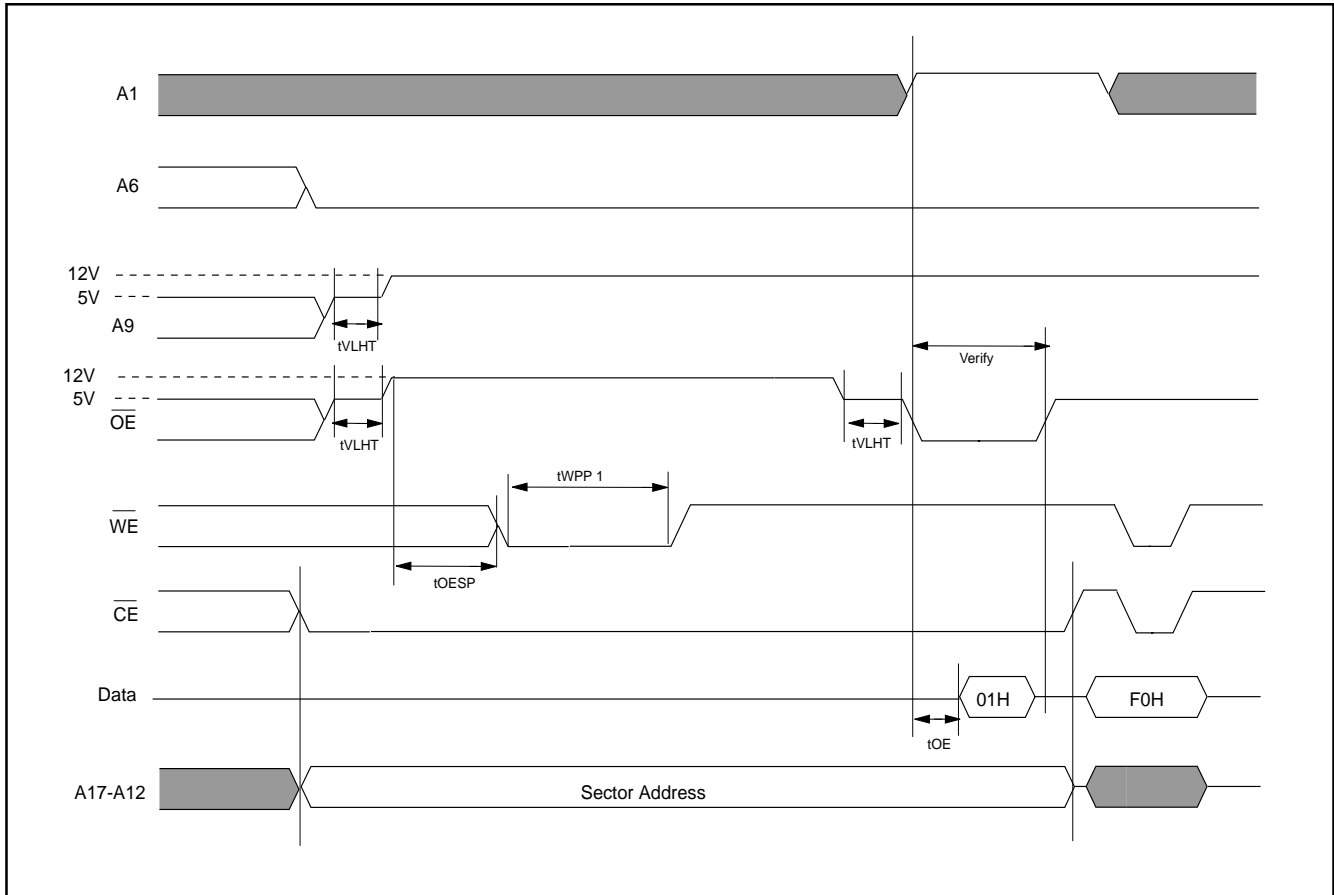
**TIMING WAVEFORM FOR SECTOR PROTECTION FOR SYSTEM WITH 12V**

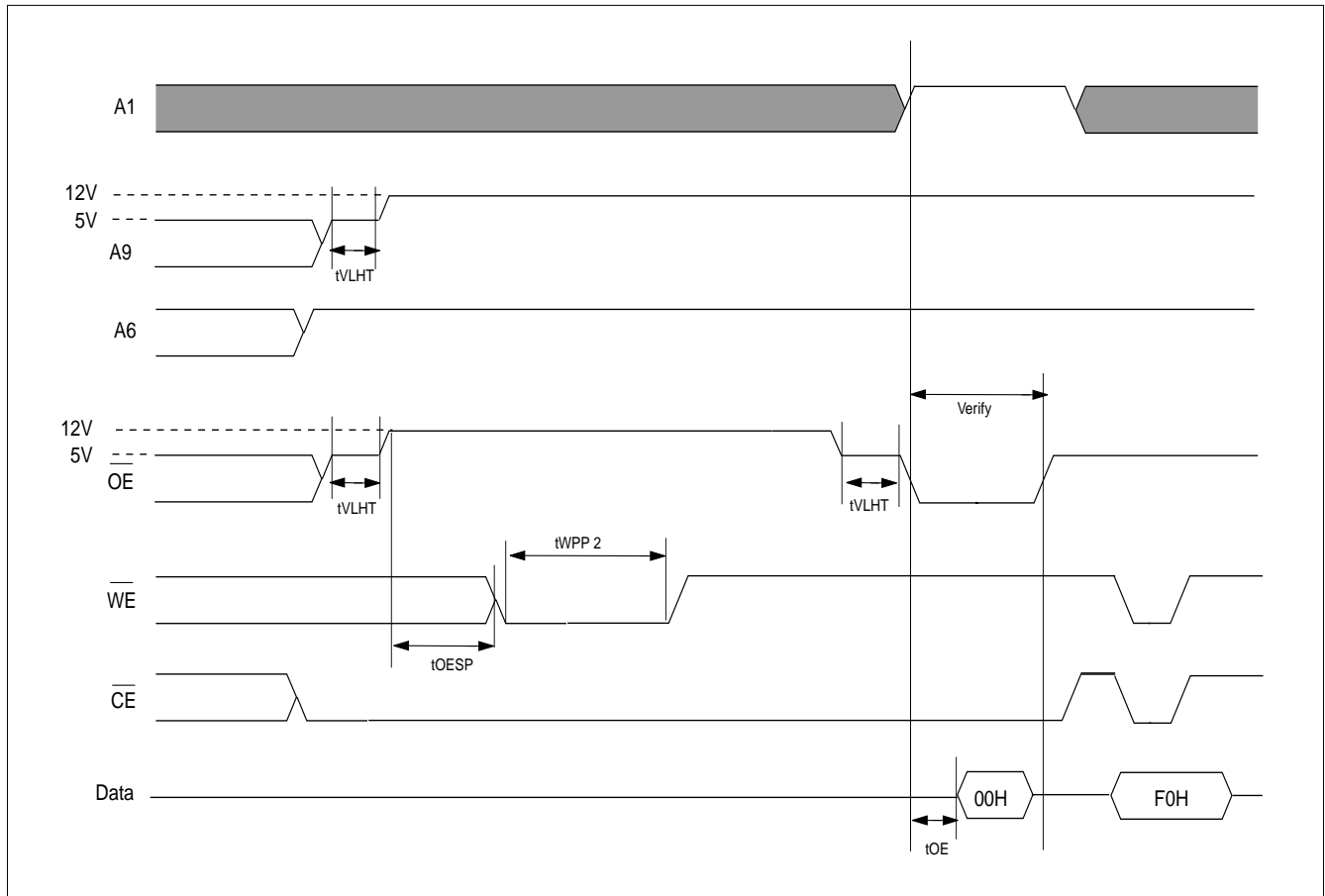
**TIMING WAVEFORM FOR CHIP UNPROTECTION FOR SYSTEM WITH 12V**

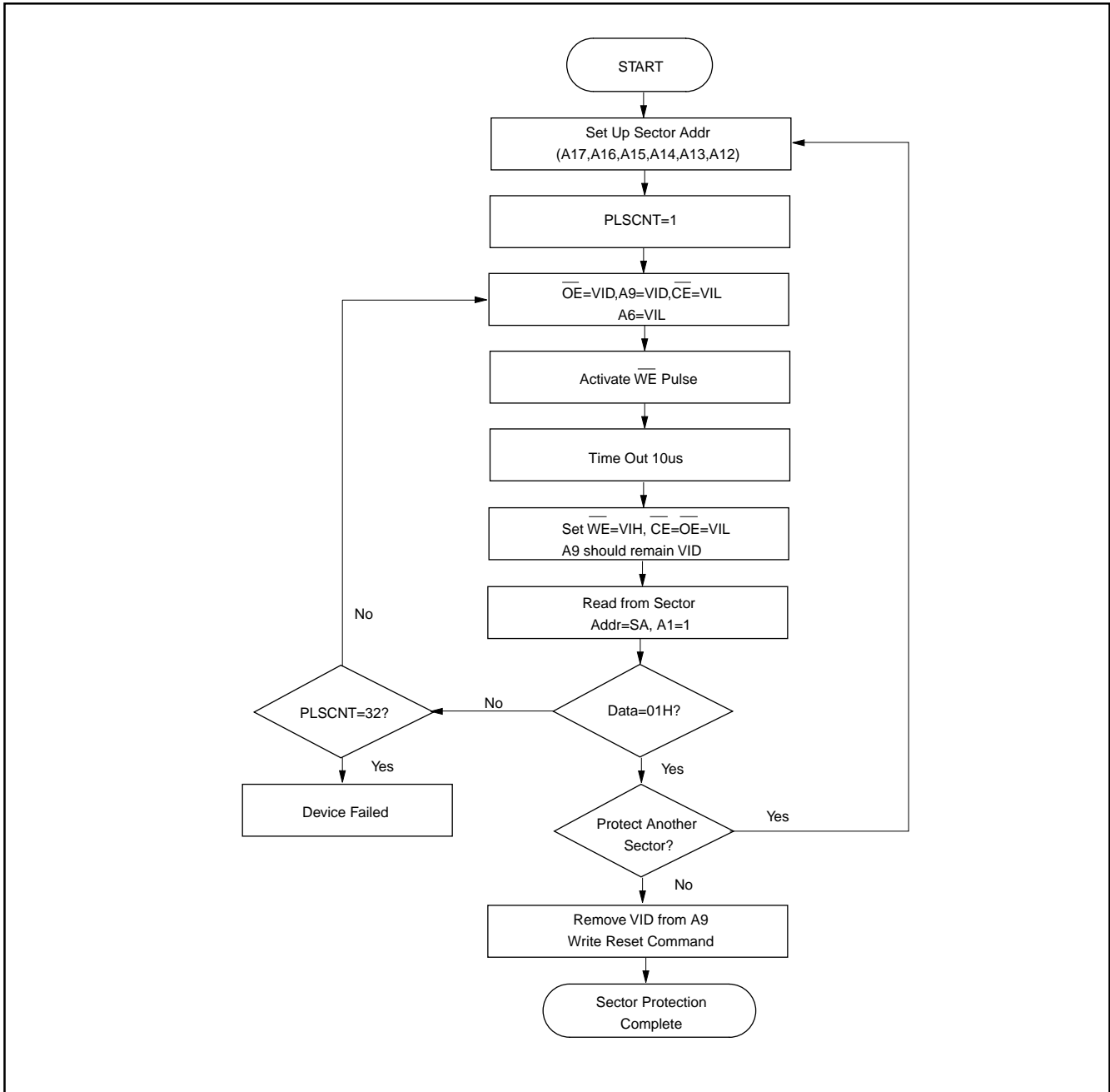
**SECTOR PROTECTION ALGORITHM FOR SYSTEM WITH 12V**

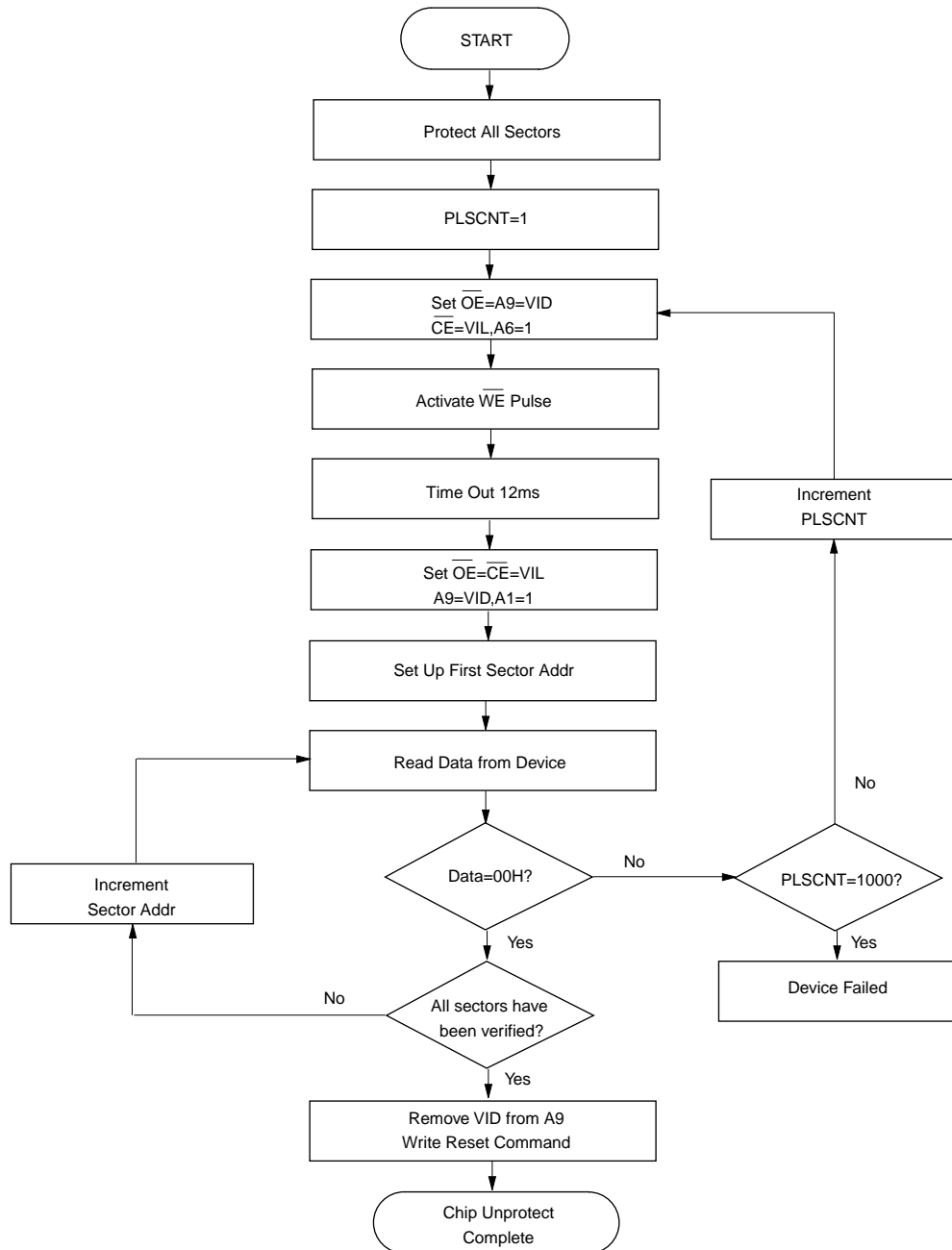

**CHIP UNPROTECTION ALGORITHM FOR SYSTEM WITH 12V**

\* It is recommended before unprotect whole chip, all sectors should be protected in advance.

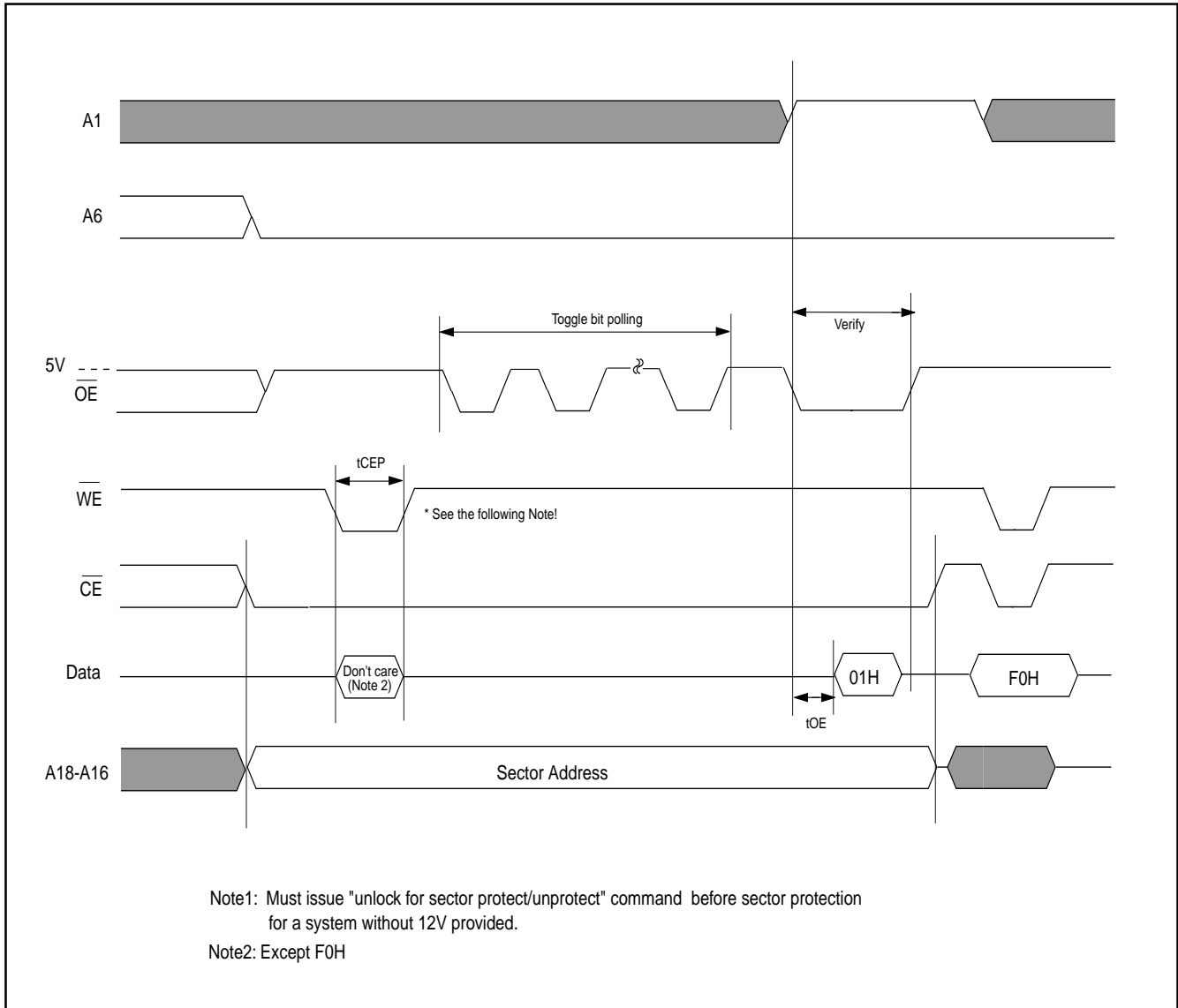
**TIMING WAVEFORM FOR SECTOR PROTECTION FOR SYSTEM WITHOUT 12V**

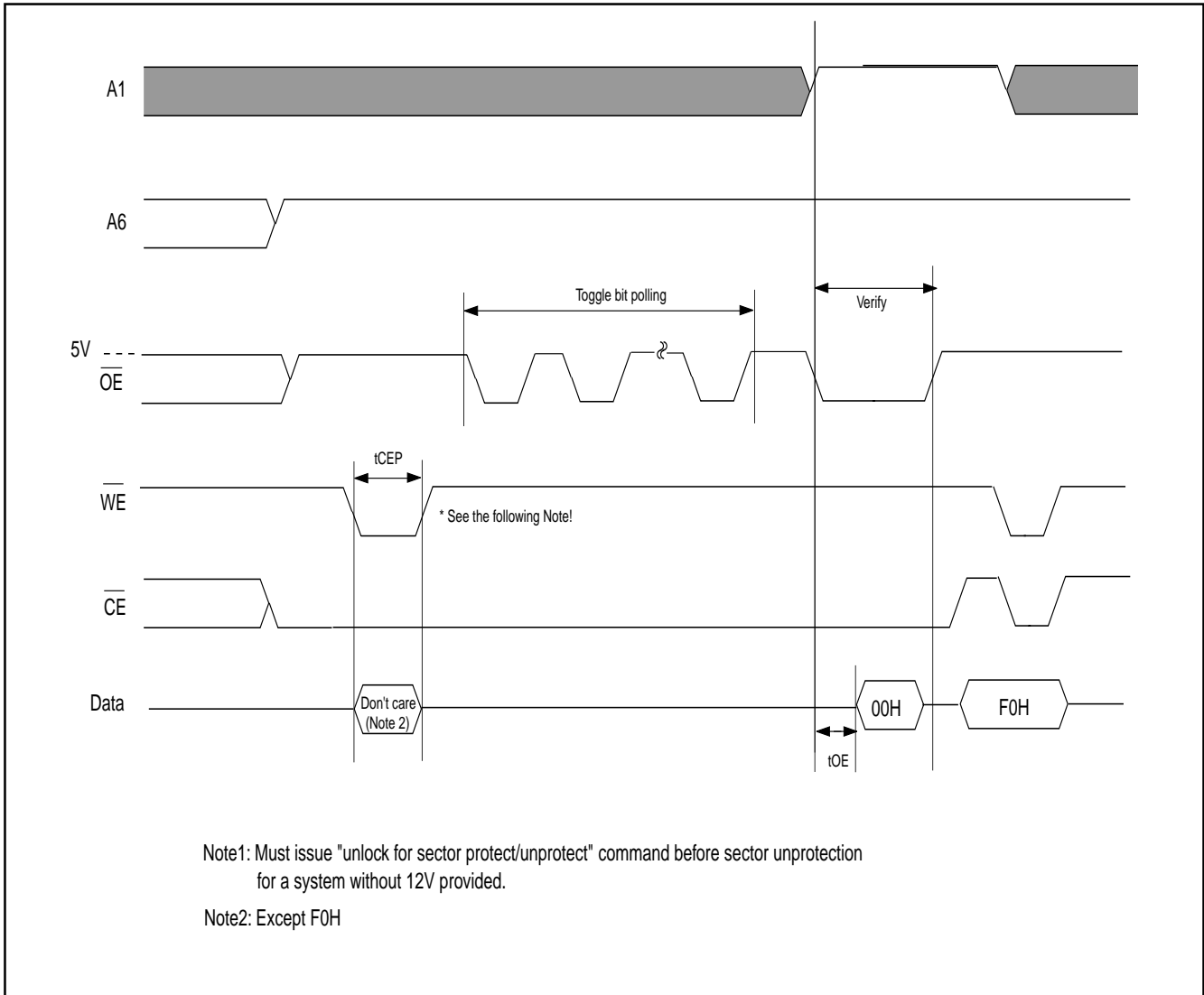
**TIMING WAVEFORM FOR CHIP UNPROTECTION FOR SYSTEM WITHOUT 12V**

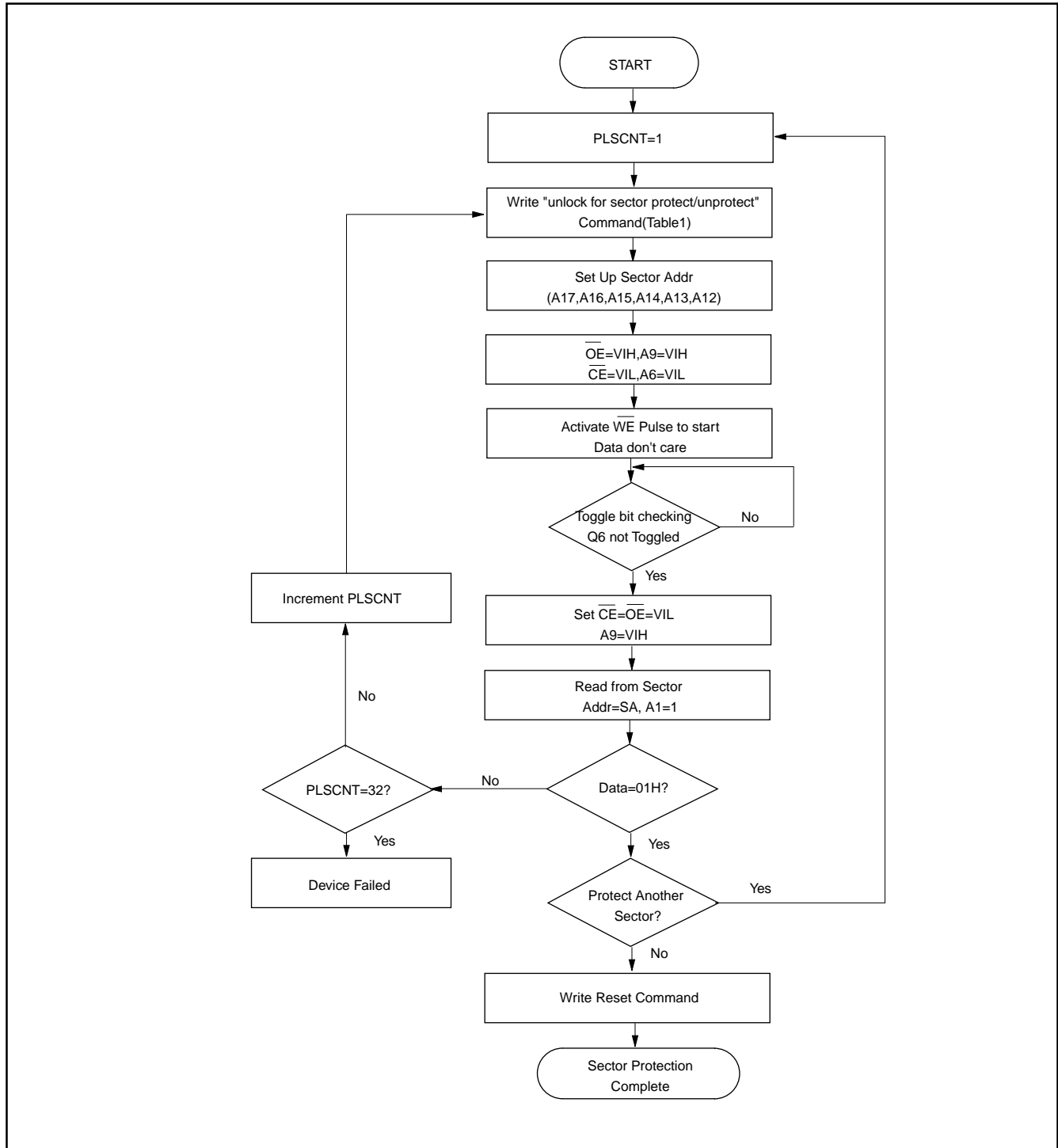
**SECTOR PROTECTION ALGORITHM FOR SYSTEM WITHOUT 12V**

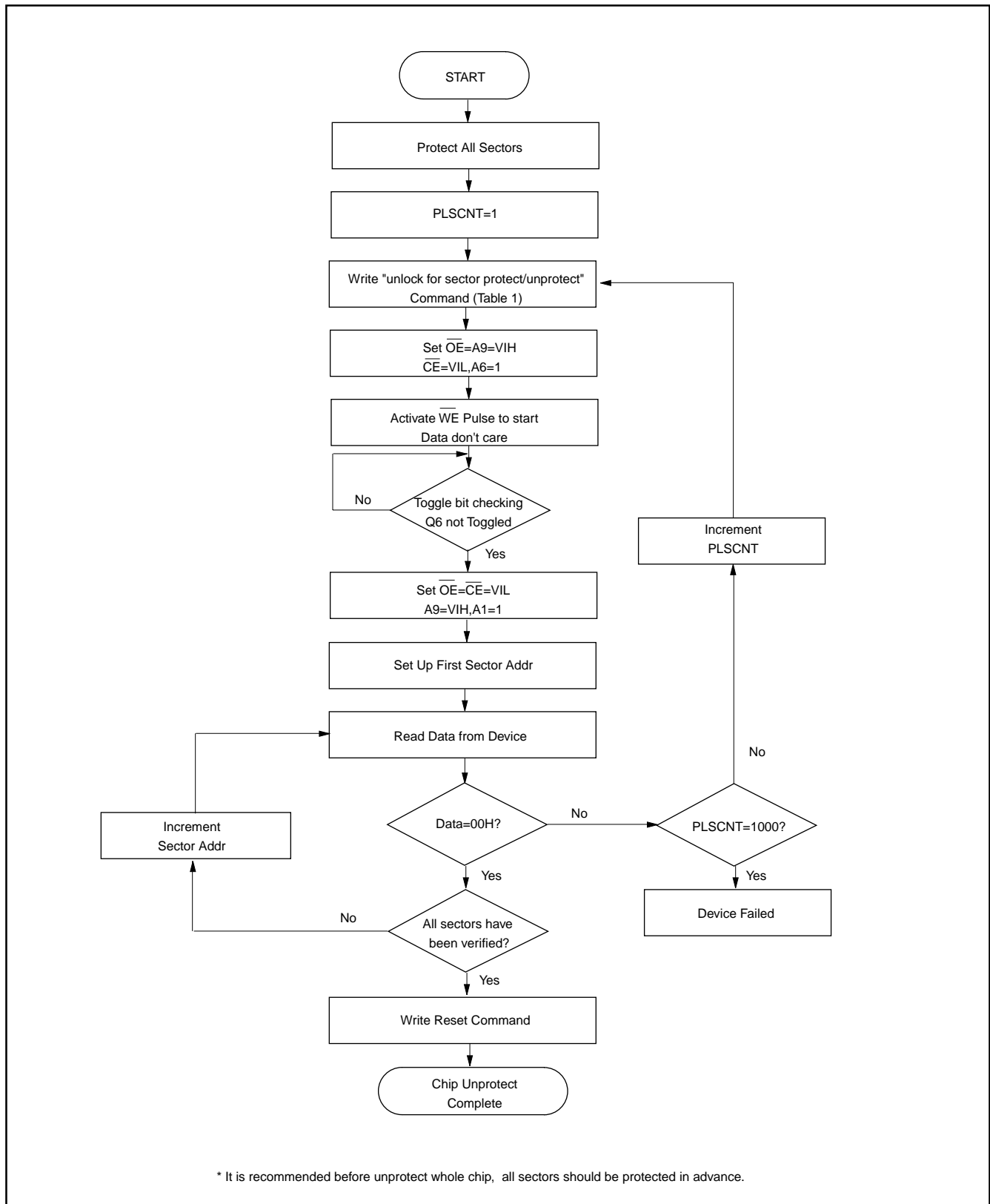
**CHIP UNPROTECTION ALGORITHM FOR SYSTEM WITHOUT 12V**

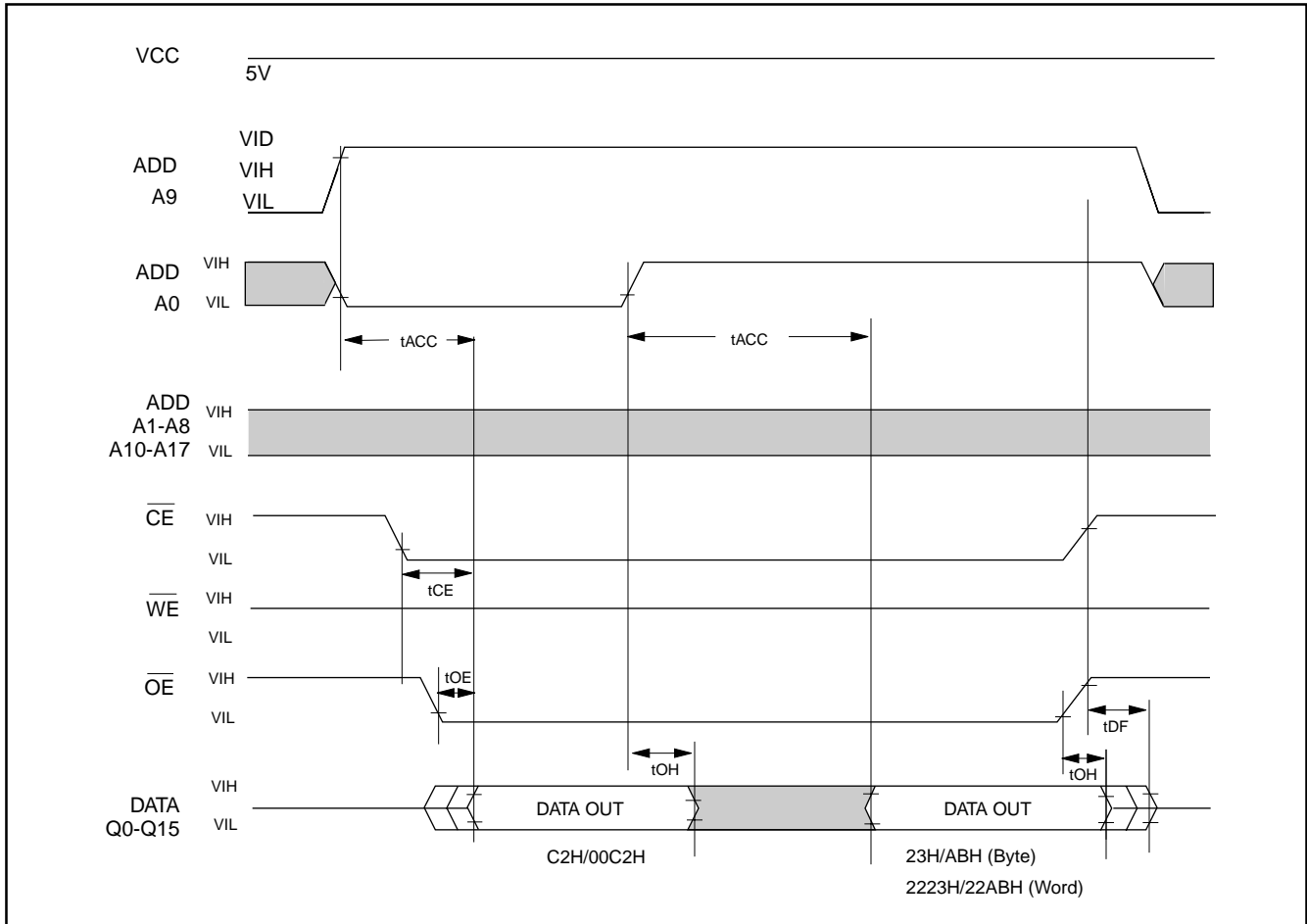
**ID CODE READ TIMING WAVEFORM**

**ERASE AND PROGRAMMING PERFORMANCE(1)**

PARAMETER	LIMITS			UNITS
	MIN.	TYP.(2)	MAX.(3)	
Sector Erase Time		1.3	10.4	sec
Chip Erase Time		4	32	sec
Byte Programming Time		7	210	us
Word Programming Time		12	360	us
Chip Programming Time		4	12	sec
Erase/Program Cycles	100,000			Cycles

Note: 1.Not 100% Tested, Excludes external system level over head.  
 2. Typical values measured at 25°C,5V.  
 3. Maximum values measured at 25°C,4.5V.

**LATCHUP CHARACTERISTICS**

	MIN.	MAX.
Input Voltage with respect to GND on all pins except I/O pins	-1.0V	13.5V
Input Voltage with respect to GND on all I/O pins	-1.0V	Vcc + 1.0V
Current	-100mA	+100mA
Includes all pins except Vcc. Test conditions: Vcc = 5.0V, one pin at a time.		

**DATA RETENTION**

PARAMETER	MIN.	UNIT
Data Retention Time	20	Years



## ORDERING INFORMATION

**PLASTIC PACKAGE** (Top Boot Sector as an sample. For Bottom Boot Sector ones, MX29F400Txx will change to MX29F400Bxx)

<b>PART NO.</b>	<b>Access Time (ns)</b>	<b>Operating Current MAX.(mA)</b>	<b>Standby Current MAX.(uA)</b>	<b>Temperature Range</b>	<b>PACKAGE</b>
MX29F400TMC-55	55	40	5	0°C~70°C	44 Pin SOP
MX29F400TMC-70	70	40	5	0°C~70°C	44 Pin SOP
MX29F400TMC-90	90	40	5	0°C~70°C	44 Pin SOP
MX29F400TMC-12	120	40	5	0°C~70°C	44 Pin SOP
MX29F400TTC-55	55	40	5	0°C~70°C	48 Pin TSOP (Normal Type)
MX29F400TTC-70	70	40	5	0°C~70°C	48 Pin TSOP (Normal Type)
MX29F400TTC-90	90	40	5	0°C~70°C	48 Pin TSOP (Normal Type)
MX29F400TTC-12	120	40	5	0°C~70°C	48 Pin TSOP (Normal Type)
MX29F400TTA-90	90	40	20	-40°C~125°C	48 Pin TSOP (Normal Type)
MX29F400TTA-12	120	40	20	-40°C~125°C	48 Pin TSOP (Normal Type)

Note:MX29F400T/B-55 is supplied by request



## PACKAGE INFORMATION

### 48-PIN PLASTIC TSOP

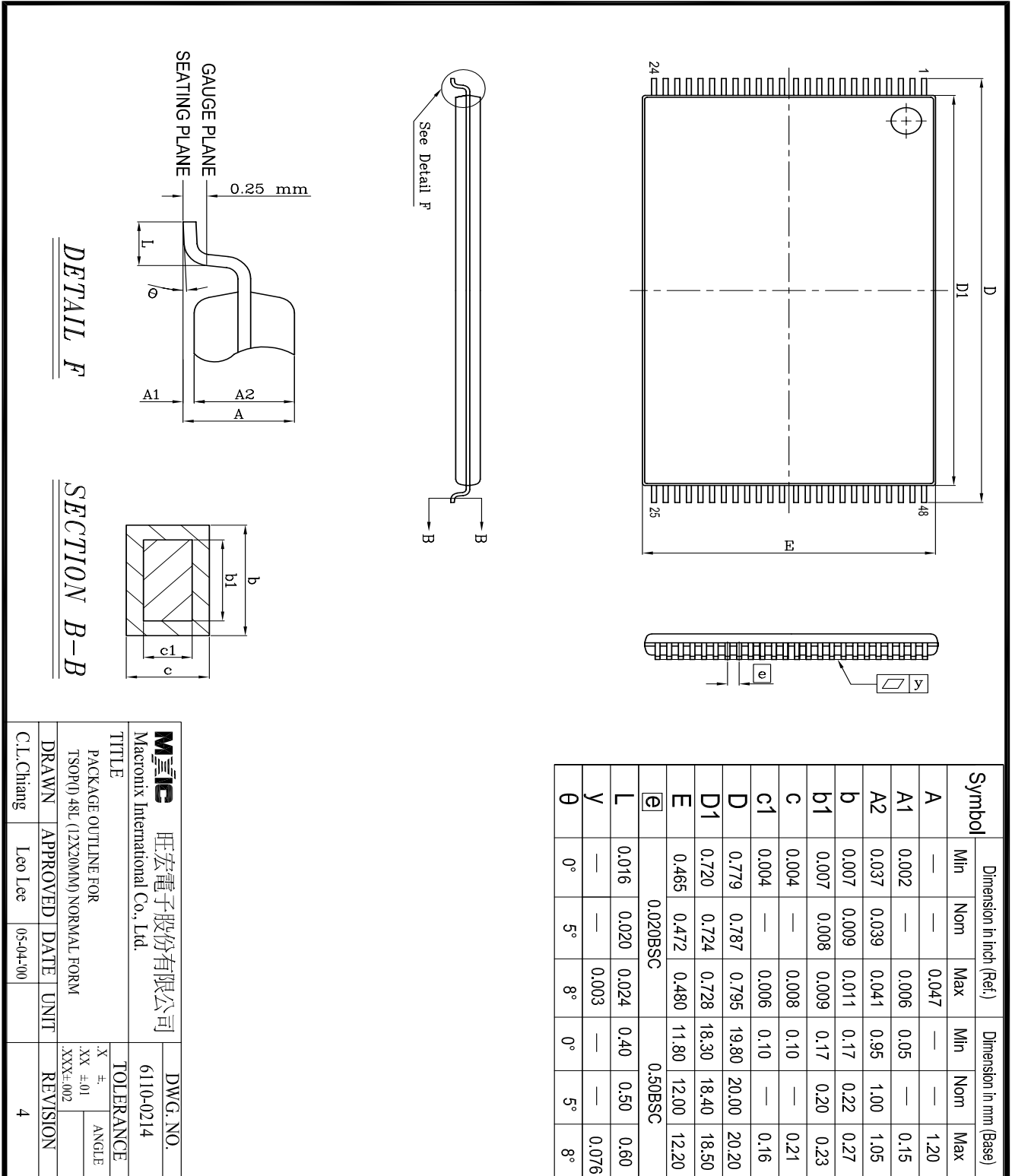

**DETAIL F**

**SECTION B-B**

<b>MIIIC</b> 旺宏電子股份有限公司 Macronix International Co., Ltd.		DWG. NO. 6110-0214	
TITLE PACKAGE OUTLINE FOR TSOP(0.48L (12X20MM)) NORMAL FORM			
TOLERANCE X # XX ±.01 .XXX±.002		ANGLE	
DRAWN C.L.Chiang	APPROVED Leo Lee	DATE 05-04-00	UNIT REVISION 4

## 44-PIN PLASTIC SOP

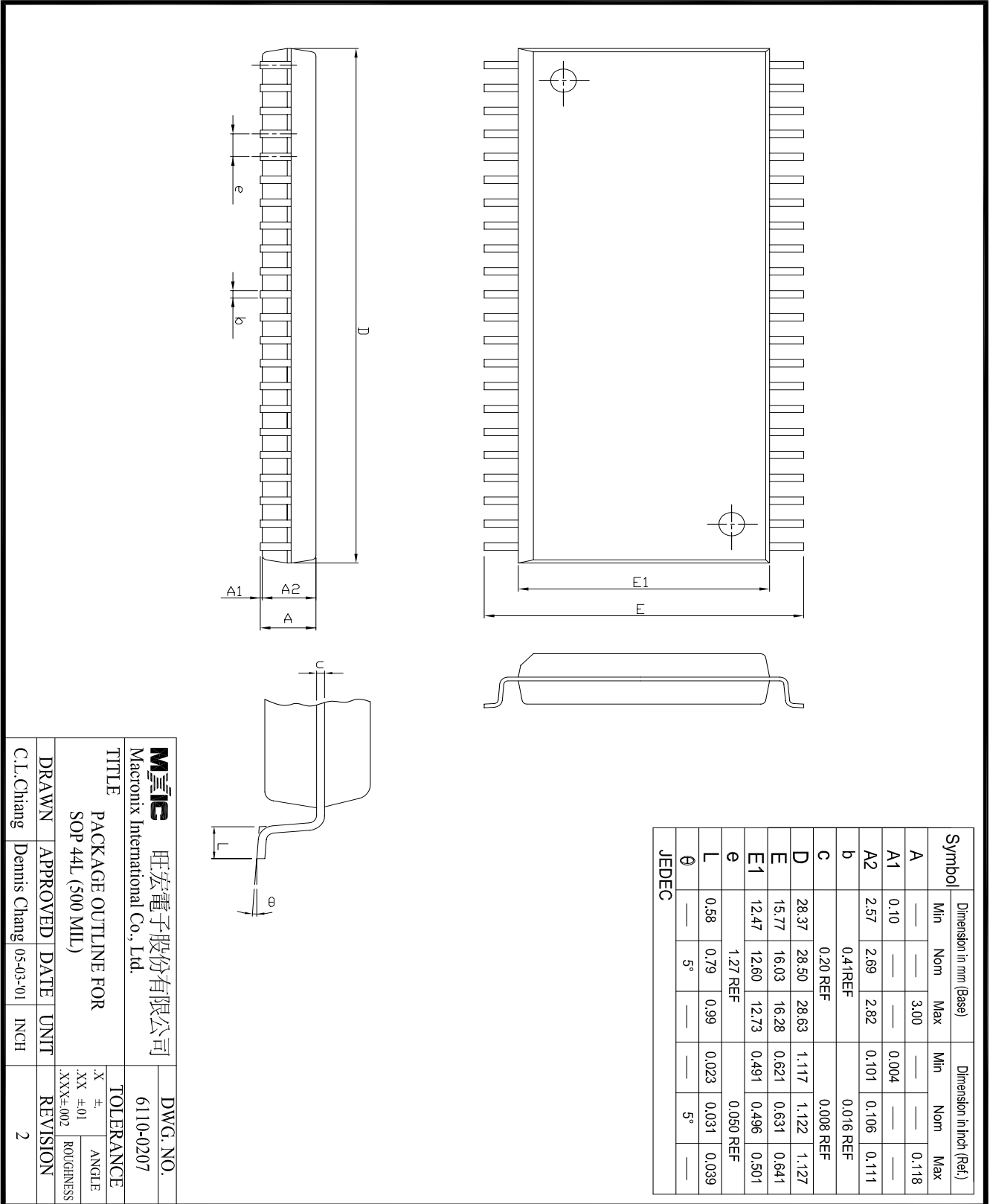

**REVISION HISTORY**

<b>Revision</b>	<b>Description</b>	<b>Page</b>	<b>Date</b>
1.0	To remove "Advanced Information" datasheet marking and contain information on products in full production.	P1	JUL/01/1999
1.1	To correct the typing error on package dimension. In fact,the physical packages are never changed,just correct the previously typing error.	P41	SEP/01/1999
1.2	To add the description for 100K endurance cycles To modify timing of sector address loading period while operating multi-sector erase from 80uS to 30uS To modify tBAL from 80uS to 100uS	P1,P40 P9 P20,P21	SEP/17/1999
1.3	1.Program/erase cycle times:10K cycles-->100K cycles 2.To add data retention minimum 20 years 3.To remove A9 from "timing waveform for sector protection for system without 12V" To remove A9 from "timing waveform for chip unprotection for system without 12V"	P1,34 P1,34 P34 P35	DEC/20/1999
1.4	Add erase suspend ready max. 100us in ERASE SUSPEND's section at page10	P10	MAY/29/2000
1.5	To modify "Package Information"	P41~42	JUN/12/2001
1.6	Add automotive grade	P16-20,40	NOV/12/2001



**MX29F400T/B**

---

---

**MACRONIX INTERNATIONAL Co., LTD.**

**HEADQUARTERS:**

TEL:+886-3-578-6688

FAX:+886-3-563-2888

**EUROPE OFFICE:**

TEL:+32-2-456-8020

FAX:+32-2-456-8021

**JAPAN OFFICE:**

TEL:+81-44-246-9100

FAX:+81-44-246-9105

**SINGAPORE OFFICE:**

TEL:+65-348-8385

FAX:+65-348-8096

**TAIPEI OFFICE:**

TEL:+886-2-2509-3300

FAX:+886-2-2509-2200

**MACRONIX AMERICA, INC.**

TEL:+1-408-453-8088

FAX:+1-408-453-8488

**CHICAGO OFFICE:**

TEL:+1-847-963-1900

FAX:+1-847-963-1909

**[http : //www.macronix.com](http://www.macronix.com)**