

# MICRO ELECTRONICS MSB31DH(S)

**HIGH EFFICIENCY  
LOW CURRENT  
RED LED LAMP**

## DESCRIPTION

MSB31DH(S) is a high efficiency low current red GaAsP/GaP LED lamp encapsulated in a 3.2mm diameter package red diffused lens.

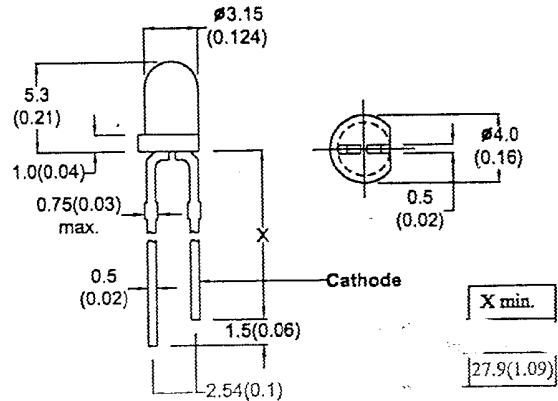

- All dimension in mm(inch)
- No Scale
- Tol. : +/-0.3mm

## ABSOLUTE MAXIMUM RATINGS

Power Dissipation @ Ta=25°C	90mW
Forward Current, DC (IF)	30mA
Reverse Voltage	5V
Operating & Storage Temperature Range	-55 to +100°C
Lead Soldering Temperature (1/16" from body)	260°C for 5 sec.

## ELECTRO-OPTICAL CHARACTERISTICS (Ta=25°C)

PARAMETER	SYMBOL	MIN	TYP	MAX	UNIT	CONDITIONS
Forward Voltage	VF			2.0	V	IF=2mA
Reverse Breakdown Voltage	BVR	5			V	IR=100 μA
Luminous Intensity	IV	1.2	2.0		mcd	IF=2mA
Peak Wavelength	λp		650		nm	IF=20mA
Spectral Line Half Width	Δλ		35		nm	IF=20mA
Viewing Angle	2θ 1/2		70		degree	IF=20mA



MICRO ELECTRONICS LTD.  
38, Hung To Road, Microtron Building, Kwun Tong, Kowloon, Hong Kong.  
Kwun Tong P.O. Box 69477 Hong Kong. Fax No. 2341 0321 Telex:43510 Micro Hx. Tel: 2343 0181-5

**Rev A**  
May-99

# MSB31DH(S)

