

# SMD POWER INDUCTORS

MODEL NO. : SPC-0703 SERIES (CDRH73 COMPATIBLE)

## FEATURES:

- \* SUPERIOR QUALITY FROM AN AUTOMATED PRODUCTION LINE.
- \* PICK AND PLACE COMPATIBLE.
- \* TAPE AND REEL PACKING.

## APPLICATION :

- \* NOTEBOOK COMPUTERS.
- \* DC-DC CONVERTORS.
- \* DC-AC INVERTERS.

## ELECTRICAL SPECIFICATION:

PART NO.	INDUCTANCE ( $\mu$ H) $\pm 20\%$	D.C.R. MAX ( $\Omega$ )	RATED CURRENT (A)
SPC-0703-100	10	0.072	1.68
SPC-0703-120	12	0.098	1.52
SPC-0703-150	15	0.13	1.33
SPC-0703-180	18	0.14	1.2
SPC-0703-220	22	0.19	1.07
SPC-0703-270	27	0.21	0.96
SPC-0703-330	33	0.24	0.91
SPC-0703-390	39	0.32	0.77
SPC-0703-470	47	0.36	0.76
SPC-0703-560	56	0.47	0.68
SPC-0703-680	68	0.52	0.61
SPC-0703-820	82	0.69	0.57
SPC-0703-101	100	0.79	0.50
SPC-0703-121	120	0.89	0.49
SPC-0703-151	150	1.27	0.43
SPC-0703-181	180	1.45	0.39
SPC-0703-221	220	1.85	0.35
SPC-0703-271	270	2.31	0.32
SPC-0703-331	330	2.62	0.28
SPC-0703-391	390	2.94	0.26
SPC-0703-471	470	4.18	0.24
SPC-0703-561	560	4.67	0.22
SPC-0703-681	680	5.73	0.19
SPC-0703-821	820	6.54	0.18
SPC-0703-102	1000	9.44	0.18

## PHYSICAL DIMENSION : (UNIT:mm)

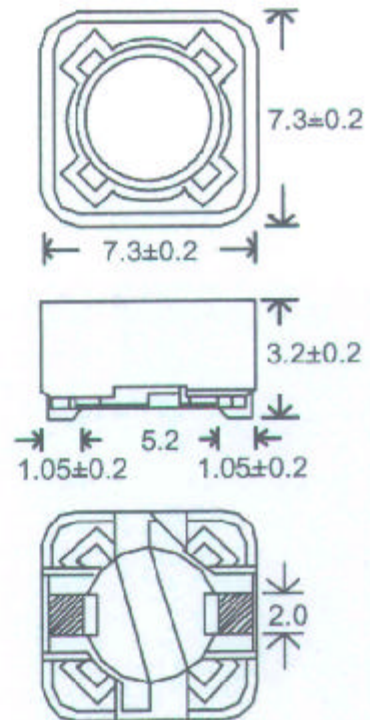

TOLERANCE:  $\pm 0.3$

NOTE(1): TEST FREQUENCY: 1KHz, 1VRMS.

NOTE(2): AT VALUE OF INDUCTANCE WHEN IS 75% DOWN FROM FIRST VALUE AS CHARACTERISTICS OF D.C. CURRENT WHEN TEMPERATURE OF COIL INCREASED UP TO 40°C. ( $T_a=20^\circ\text{C}$ )

## PACKING

### Tape and Reel Orientation

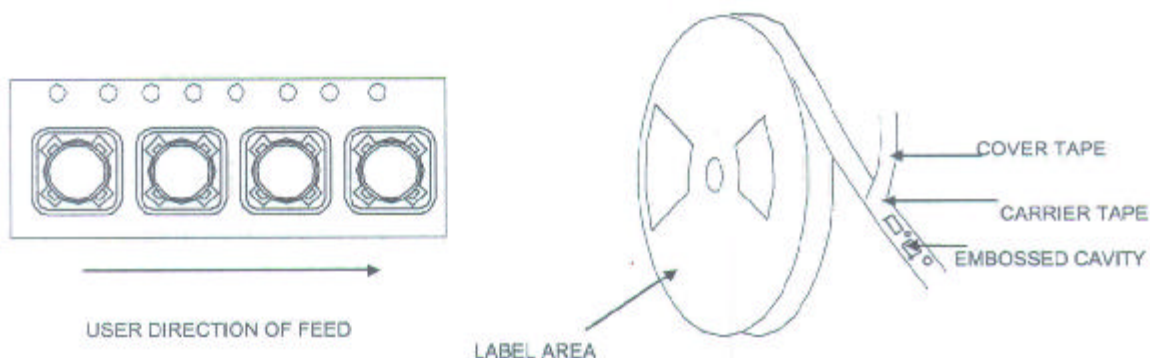

NOTE : Top view shown with cover tape removed.

TAPE WIDTH	REEL WIDTH	COMPONENT PITCH	UNITS PER REEL
16mm	22.4mm	12mm	1500

#### TAPE SPECIFICATIONS:

Carrier Tape Type : Conductive.

Cover Tape Type : Antistatic.

Cover Tape Adhesion to Carrier : 10 - 70 grams.

#### REEL SPECIFICATIONS:

Diameter (flange) : 13" (330.2mm)

STANDARDS : All embossed carrier tape packaging will be accomplished in compliance with latest revision of EIA-481

\*Taping of surface Mount Components for Automatic Placement\*.

## ENVIRONMENTAL PERFORMANCE

ITEM	TEST	CONDITION
1	Thermal Shock	one cycle shall consist of : (1) 30 minutes at temperature -30°C. (2) 15 seconds maximum at room ambient. (3) 30 minutes at temperature +85°C. (4) 15 seconds maximum at room ambient. Subject samples to 10 cycles. Test per applicable devices specification after a 4 hours stabilization at room ambient.
2	Vibration	Inductance deviation within±3.0% after vibration for 1 hour. In each of three orientations at sweep vibration (10~50~10Hz) with 1.5mm P-P amplitude.
3	Solderability	Solder pot at 230°C±5°C, with kester 1544 solder flux. Dip parts into solder pot containing 63/37 molten alloy for 6 second±1 second. Wetting must occur on a minimum of 90% of the terminations.
4	Operating Temperature	-25°C ~+80°C ( coil contain heat).
5	Humidity	Inductance deviation within±5.0%. After 96 hour in 90~95% relative humidity at 40±2°C and 1 hour drying under normal condition.
6	Mechanical Shock	Inductance deviation within ±3.0% after drop down with 981m/s <sup>2</sup> (100G) shock. Attitude upon a rubber block method shock testing machine, for 1 time, in each of three orientations.