

General Description

The MIC2529 is a high-side power switch optimized for self-powered (individual port switching) and bus-powered (ganged port switching) Universal Serial Bus (USB) hub applications. An on-board voltage regulator provides the 3.3V supply voltage needed for many USB microcontrollers reducing board component count.

The MIC2529 satisfies the following USB requirements: it supplies up to 500mA as required by USB downstream devices; the switch's low on-resistance meets USB voltage drop requirements; fault current is limited to typically 750mA, well below the UL 25VA safety requirement; and a flag output is available to indicate fault conditions to the local USB controller. Soft start eliminates the momentary voltage drop on the upstream port that may occur when the switch is enabled in bus-powered applications.

A low-dropout (LDO) regulator provides 3.3V at loads up to 100mA and includes an enable pin for low current shutdown. Both enable inputs are compatible with 3.3V and 5V logic. Thermal shutdown prevents catastrophic failure from high-current loads.

The MIC2529 is available in an 8-pin SOIC package with active-high or active-low enable circuitry on switch.

Features

- Compliant to USB specifications
- UL Recognized Component
- On-board 3.3V, 100mA low-dropout regulator
- 500mA minimum continuous switch load current
- 160mΩ maximum on-resistance
- 750mA typical current limit
- Open-drain fault flag pin for switch
- Output can be forced higher than input (off-state)
- Thermal shutdown
- 1ms turn-on (soft-start) and fast turnoff
- Available with active-high or active-low switch enable
- Active-high enable on 3.3V regulated output
- 8-pin SOIC package

Applications

- USB self-powered hubs
- USB bus-powered hubs
- USB keyboard hubs

Typical Applications

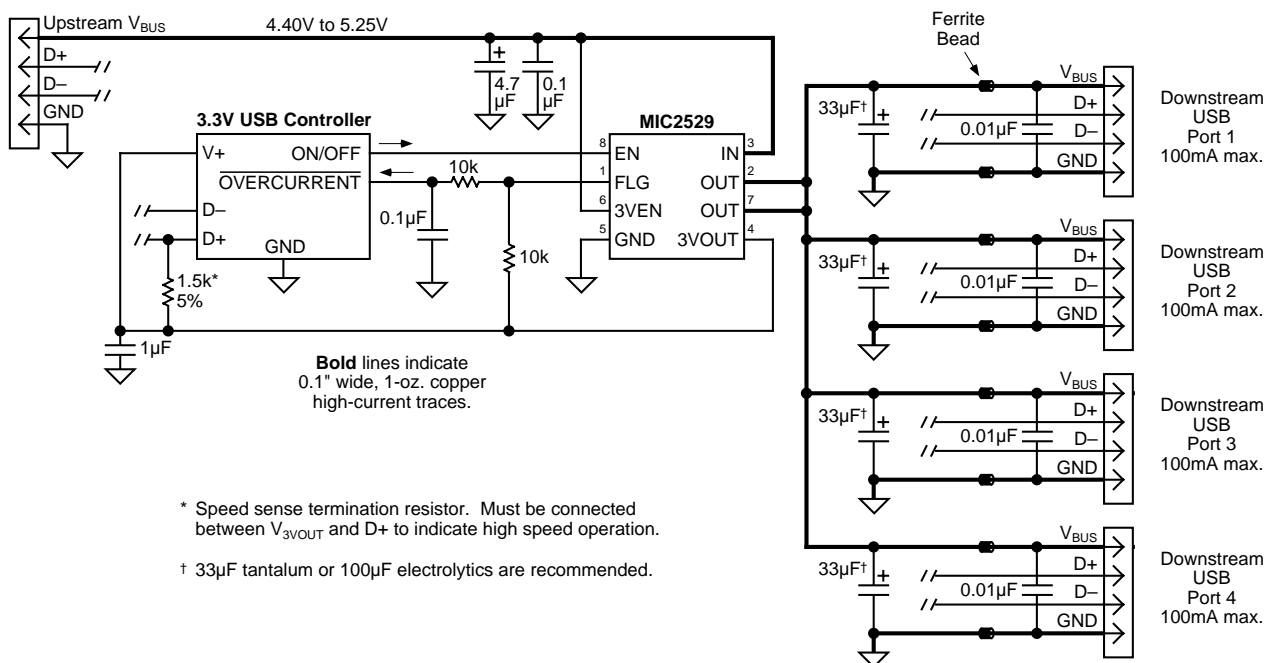

UL Recognized Component

4-Port Ganged Bus-Powered Hub

Ordering Information

Part Number	Switch Enable	Temperature Range	Package
MIC2529-1BM	Active High	-40°C to +85°C	8-Pin SOIC
MIC2529-2BM	Active Low	-40°C to +85°C	8-Pin SOIC

Pin Configuration

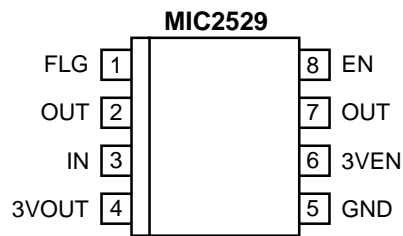

8-Pin SOIC (M)

Pin Description

Pin Number	Pin Name	Pin Function
1	FLG	Fault Flag (Output): Active-low, open-drain output. Indicates overcurrent and thermal shutdown switch conditions.
2, 7	OUT	Switch Output: Output MOSFET source. Typically connected to switched side of load. Pin 2 and 7 must be connected together externally.
3	IN	Supply Voltage Input. Supply to switch and regulator. Connect to positive supply.
4	3VOUT	3.3V Regulator Output
5	GND	Ground: Supply return.
6	3VEN	Regulator Enable (Input): Logic-compatible input. Logic high = enable, logic low or open = shutdown. Do not float.
8	EN	Switch Enable (Input): Logic-compatible enable input. High input = 2.1V typical. Low input = 1.9V typical. (-1 active high, -2 active low) Do not float.

Absolute Maximum Ratings (Note 1)

Supply Voltage (V_{IN})	+6V
Fault Flag Voltage (V_{FLG})	+6V
Fault Flag Current (I_{FLG})	50mA
Switch Output Voltage (OUT)	+6V
Switch Output Current (I_{OUT})	Internally Limited
Switch Control Input (V_{EN})	-0.3V to +12V
Regulator Control Input (V_{3VEN})	-20V to +20V
Storage Temperature (T_S)	-65°C to +150°C
Lead Temperature (soldering 5 sec.)	260°C

Operating Ratings (Note 2)

Supply Voltage (V_{IN})	+3V to +5.5V
Ambient Temperature (T_A)	-40°C to +85°C
Thermal Resistance	
SOIC (θ_{JA})	160°C/W

Electrical Characteristics

$V_{IN} = +5V$; $T_A = 25^\circ C$; unless noted.

Parameter	Condition	Min	Typ	Max	Units
Supply Current	$V_{3VEN} = \text{high}$, switch EN off, Note 3		80	150	μA
	$V_{3VEN} = \text{high}$, switch EN on, OUT = open, Note 3		160	300	μA
EN Input Threshold	low to high transition		2.1	2.4	V
	high to low transition, Note 3	0.8	1.9		V
Enable Input Current	$V_{EN} = 0 - 5.5V$		0.01		μA
Enable Input Capacitance			1		pF
Switch Resistance	$V_{IN} = 5V$; $I_{OUT} = 500mA$		120		m Ω
	$V_{IN} = 3.3V$; $I_{OUT} = 500mA$		160		m Ω
Output Turn-On Delay	$R_L = 10\Omega$		0.25		ms
Output Turn-On Rise Time	$R_L = 10\Omega$		3		ms
Output Turnoff Delay	$R_L = 10\Omega$		1	20	μs
Output Turnoff Fall Time	$R_L = 10\Omega$		1	20	μs
Output Leakage Current				10	μA
Continuous Load Current	FLG not active	0.5			A
Short Circuit Current Limit	enabled into load, $V_{OUT} = 0V$	0.5	0.75	1.25	A
Current-Limit Threshold	ramped load applied to enabled output, $V_{OUT} = 0V$, Note 4		0.95	1.50	A
Overtemperature Shutdown Threshold	T_J increasing		135		$^\circ C$
	T_J decreasing		125		$^\circ C$
Error Flag Output Resistance	$V_{IN} = 5V$, $I_L = 10mA$		20		Ω
	$V_{IN} = 3.3V$, $I_L = 10mA$		30		Ω
Error-Flag Off Current	$V_{FLAG} = 5V$		0.01	1	μA
3VEN Input Threshold	enable input logic-low voltage (regulator shutdown)			0.4	V
	enable input logic-high voltage (regulator enabled)	2.0			V
3VEN Input Current	$V_{IL} \leq 0.4V$		0.01	-1	μA
	$V_{IH} \geq 2.0V$		5	20	μA

Parameter	Condition	Min	Typ	Max	Units
Regulator Output Voltage	$V_{IN} = 4.0V$ to $5.25V$, $I_L = 100mA$	3.14	3.3	3.47	V
Regulator Output Voltage Temperature Coefficient	Note 5		50		ppm/°C
Regulator Line Regulation	$V_{IN} = 4.0V$ to $5.25V$		0.3		mV
Regulator Load Regulation	$I_L = 0.1mA$ to $100mA$		3		mV
Regulator Dropout Voltage	$I_L = 100mA$, Note 6				mV
Regulator Current Limit	$3V_{OUT} = 0V$		320		mA

Note 1. Exceeding the absolute maximum rating may damage the device. Devices are ESD sensitive. Handling precautions recommended.

Note 2. The device is not guaranteed to function outside its operating rating.

Note 3. Off is $\leq 0.8V$ and on is $\geq 2.4V$ for the MIC2529-1 switch. Off is $\geq 2.4V$ and on is $\leq 0.8V$ for the MIC2529-2 switch. The enable input has approximately 200mV of hysteresis. See control threshold charts. Limits do not include $3V_{OUT}$ load current of 100 μA during test.

Note 4. See "Functional Characteristics: Current-Limit Response" photo.

Note 5. Output voltage temperature coefficient is defined as the worst case voltage change divided by the total temperature range.

Note 6. Dropout voltage is defined as the input to output differential at which the output voltage drops 2% below its nominal value measured at 1V differential.

Typical Characteristics

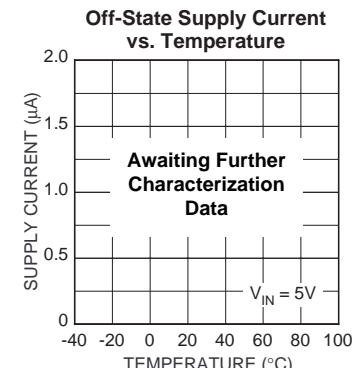
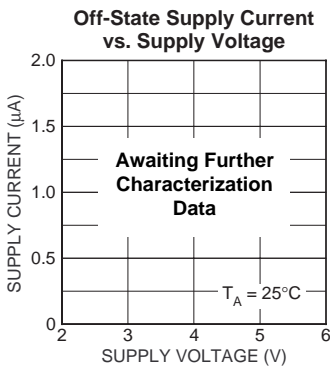
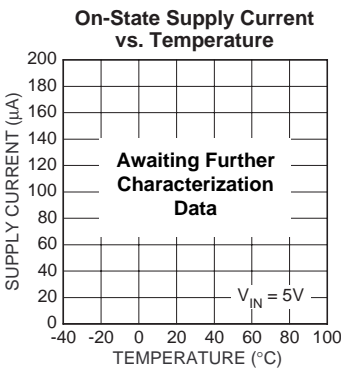
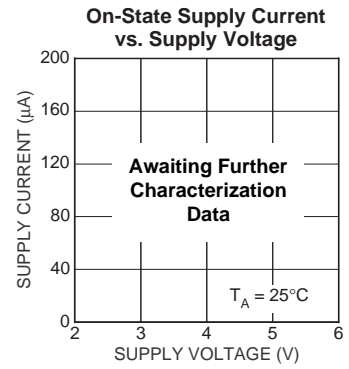
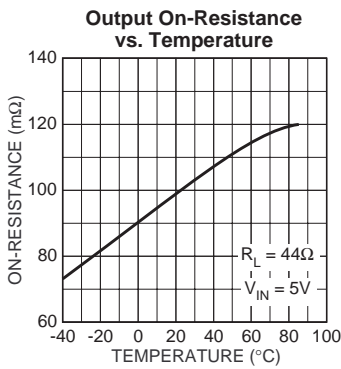
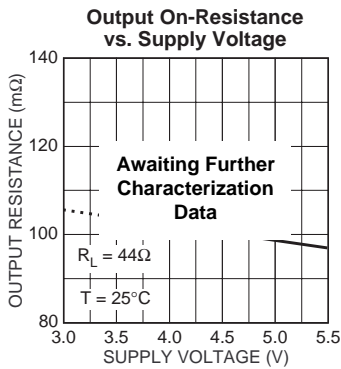

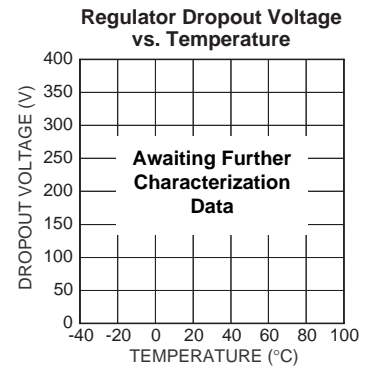
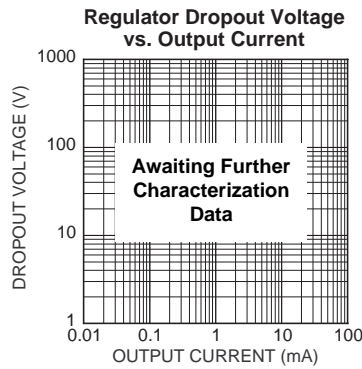
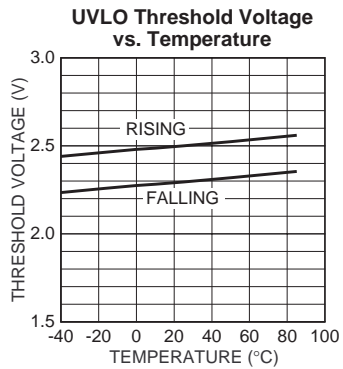
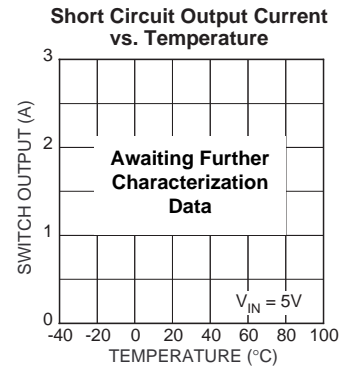
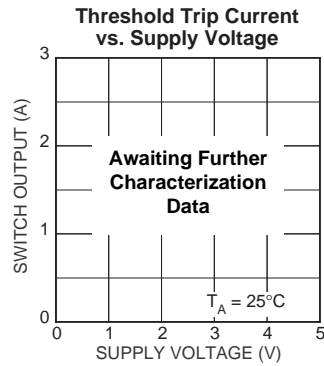
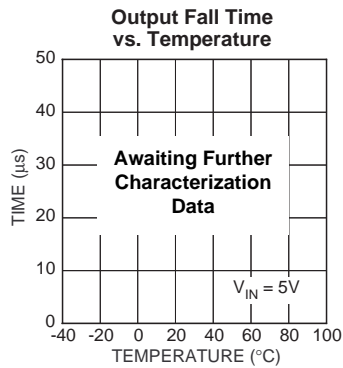
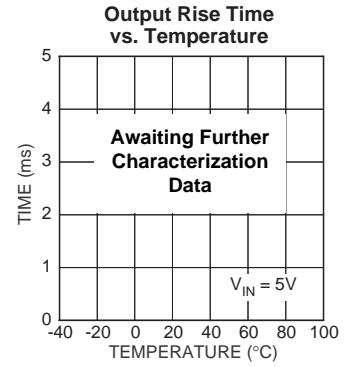
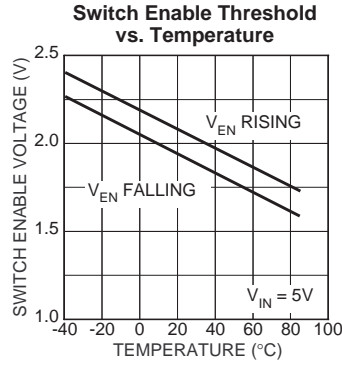
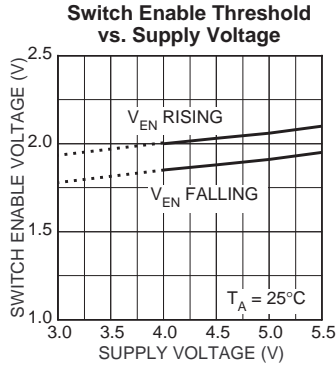

Functional Characteristics

Short-Circuit Response
Short Applied to Output

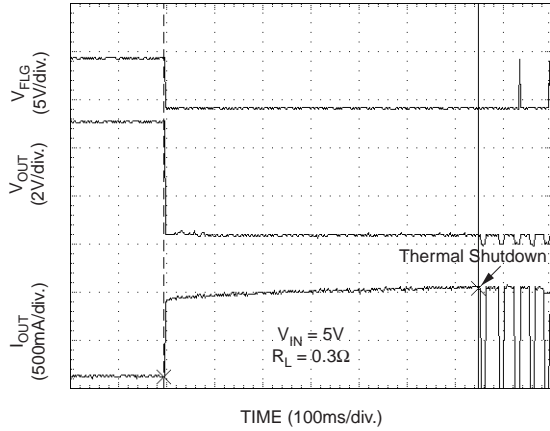

Short Circuit Transient Response
Short Applied to Output

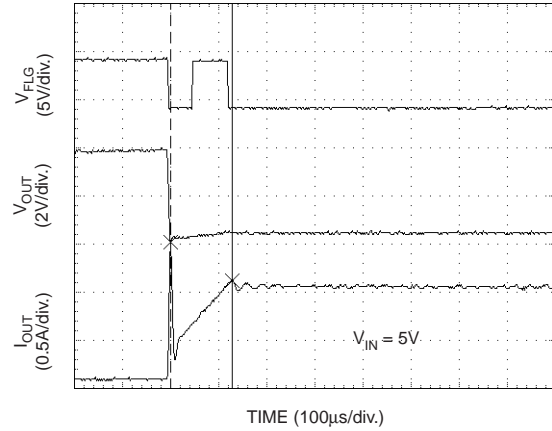

Short Circuit Response
Enabled into Short Circuit

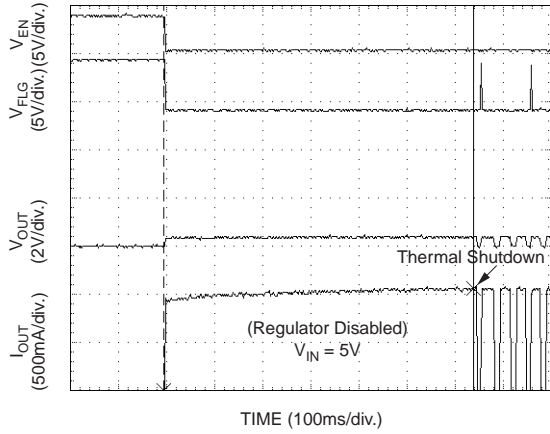

Current Limit Response

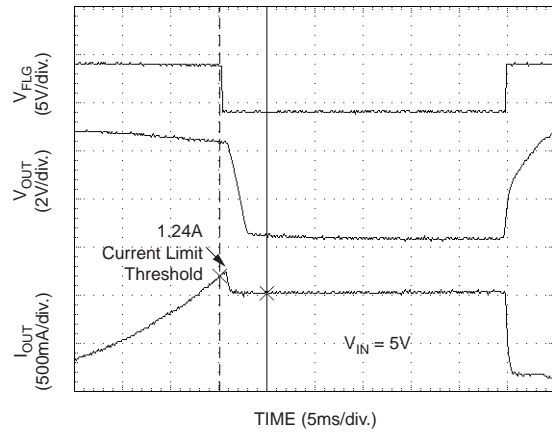

Turn-On and Turnoff
Characteristics

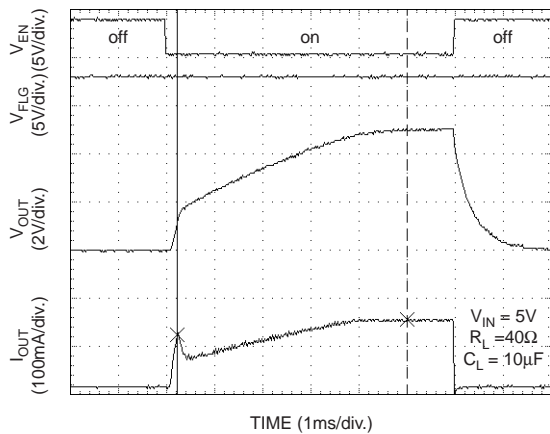

Turn-On and Turnoff
Characteristics

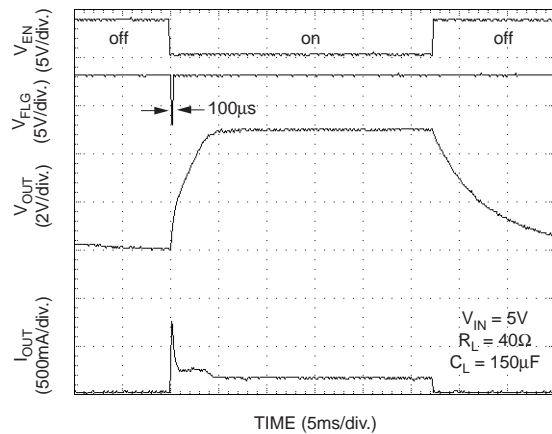

Test Circuit

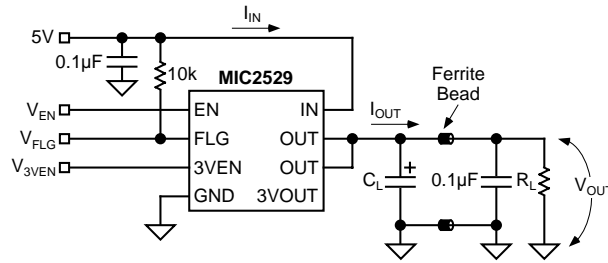

Functional Characteristics Test Circuit

Block Diagram

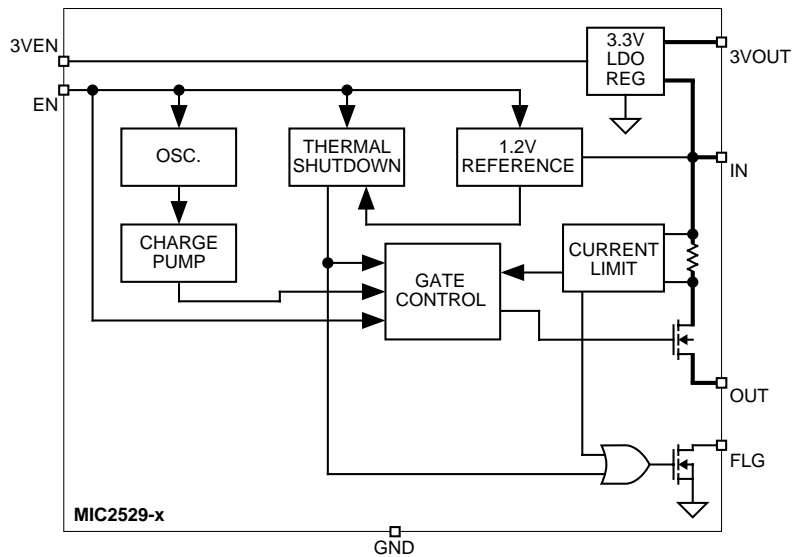

Functional Description

The MIC2529-1 and MIC2529-2 are high-side power switches with on-board voltage regulators. Switch fault conditions turn off or inhibit turn-on of the output transistor, depending upon the type of fault, and activate the open-drain error flag transistor, making it sink current to ground.

Input and Output

IN (input) is the power supply connection to the logic circuitry, drain of the output MOSFET, and the voltage regulator input. 3VOUT is the regulated 3.3V output. OUT (output) is the source of the MOSFET switch. In a typical circuit current flows through the switch from IN to OUT toward the load. Both OUT pins must be connected together externally. If V_{OUT} is greater than V_{IN} when a switch is disabled, current will flow from OUT to IN when the switch is enabled since the switch is bidirectional when enabled.

The output MOSFET and driver circuitry are also designed to allow the MOSFET source to be externally forced to a higher voltage than the drain ($V_{OUT} > V_{IN}$) when the output is off.

Thermal Shutdown

Thermal shutdown shuts off the switch and activates the flag if the die temperature exceeds 135°C. 10°C of hysteresis prevents the switch from turning on until the die temperature drops to 125°C. Switch overtemperature detection functions only when the switch is enabled. The internal LDO regulator has a similar shutdown without flag output.

When an excessive load is applied to the switch output, the MIC2529 will enter a thermal shutdown condition. As shown in the “Electrical Characteristics” short-circuit response graphs, the thermal time constant is about 640ms for the initial condition. If the channel is not shut off, the output will go into thermal oscillation with a frequency of about 20Hz. While this will not damage the device, it is recommended that the port is shut down prior to this occurring.

Switch Current Sensing and Limiting

The current limit threshold is preset internally. The preset level prevents damage to the switch output MOSFET and external load but allows a minimum current of 0.5A through the switch output MOSFET.

The current limit circuit senses a portion of the output switch (FET) current. The current sense resistor shown in the block diagram is virtual and has no voltage drop. The reaction to an overcurrent varies with three scenarios:

Switch Enabled into Short Circuit

If the switch is powered on or enabled into an excessive load or short circuit, the switch current ramps up to a constant current. The fault flag goes low until the load is reduced. See the “Functional Characteristic: Short Circuit Response, Enabled into Short Circuit” photo.

Short Circuit Applied to Outputs

When a heavy load or short circuit is applied to an enabled switch, a large transient current will flow until the current limit circuitry responds. Once this occurs, the device limits current to less than the short circuit current specification. See “Functional Characteristic: Short Circuit Response, Short Applied to Output” graph.

Current-Limit Response

The MIC2529 current-limit profile exhibits a small foldback effect of approximately 200mA. Once this current-limit threshold is exceeded the device enters constant-current mode. This constant current is specified as the short circuit current limit in the “Electrical Characteristics” table. It is important to note that the MIC2529 will deliver load current up to the current-limit threshold. Refer to “Functional Characteristics: Current-Limit Response” photo for details.

Fault Flag

FLG is an open-drain N-channel MOSFET output. The fault flag is active (low) for one or more of the following switch conditions: current limit or thermal shutdown. The flag output MOSFET is capable of sinking a 10mA load to typically 100mV above ground. The flag does not indicate faults in the LDO regulator.

Applications Information

Supply Filtering

A 0.1 μ F to 1 μ F bypass capacitor from IN to GND, located at the device, is strongly recommended to control supply transients. See Figure 1. Without a bypass capacitor, an output short may cause sufficient ringing on the input (from supply lead inductance) to damage internal control circuitry.

Input or output transients must not exceed the absolute maximum supply voltage ($V_{IN(max)} = 6V$) even for a short duration.

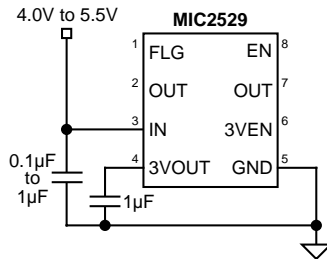

Figure 1. Supply Bypassing

Regulator Output Capacitor

A 1 μ F output capacitor is required between 3VOUT and GND to prevent oscillation. Larger values improve the regulator's transient response. The output capacitor value may be increased without limit.

The output capacitor should have an ESR (effective series resistance) of about 5 Ω or less and a resonant frequency above 1MHz. Most tantalum or aluminum electrolytic capacitors are adequate. Film types will work but are more expensive. Since many aluminum electrolytics have electrolytes that freeze at about -30°C , solid tantalums are recommended for operation below -25°C .

The regulator will remain stable and in regulation with no load other than the internal voltage divider, unlike many other voltage regulators.

Switch Enable Input

EN must be driven logic high or logic low for a clearly defined input. Floating the input may cause unpredictable operation. EN should not be allowed to go negative with respect to GND.

Regulator Enable Input

Forcing 3VEN (regulator enable/shutdown) high enables the regulator. Like EN, 3VEN is compatible with CMOS logic gates.

If the enable/shutdown feature is not required, connect 3VEN to IN.

Transient Overcurrent Fault-Flag Filter

When the MIC2529 is enabled, large values of capacitance at the output of the device may cause inrush currents to flow that exceed the short circuit current-limit threshold of the device and cause the flag to activate. The duration of this time depends on the size of the output capacitance. Refer to

“Functional Characteristics: Switch Turn-On and Turnoff Characteristics” for details. During the charging time, the device enters into constant-current mode and the flag is activated. As the capacitance is charged, the current decreases below the short circuit current-limit threshold and the flag will be deasserted.

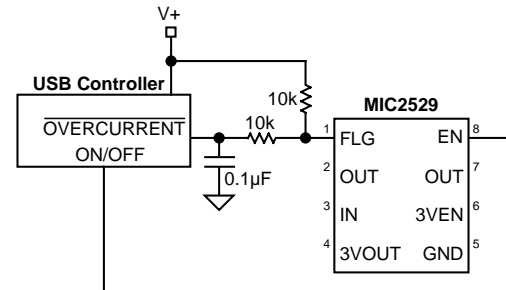

Figure 2. Transient Filter

In USB applications it is required that output bulk capacitance, shown in “Typical Application,” is utilized to meet transient regulation requirements during hot-plug events. When the MIC2529 is enabled into this capacitive load, the flag may go active for about 200 μ s. Additionally, during hot-plug events, inrush currents will also cause the flag to go active for approximately 30 μ s. Since these conditions are not valid overcurrent faults, the USB controller must ignore the flag during these events. To prevent this erroneous overcurrent reporting, a 1ms RC filter must be used (see Figure 2).

Bus-Powered Hub Applications

The MIC2529 was designed for self-powered or bus-powered hubs. The integrated regulator reduces cost and space in applications using a 3.3V USB controller. For self-powered hubs, the MIC2529 will support 1 downstream port. For bus-powered hubs, the MIC2529 will support up to four ganged downstream ports.

Bus-Powered Hub Port Switching

The USB Specification requires that bus-powered hubs implement port switching on either a ganged or individual basis. The specific implementation must be reported via the Hub Descriptor Status Register. Individual port switching does have some advantages in that a fault on one port will not prevent the other ports from operating correctly. In addition, a soft-start circuit must be included in order to reduce inrush currents when the switch is enabled. To meet this requirement, the MIC2529 has been designed to slowly ramp its output.

The USB Specification does not require bus-powered hubs to report overcurrent conditions to the host since the hub is already current-limited at the upstream port. However, if it is desired to report overcurrent, the Hub Descriptor Status Register must be programmed to indicate this. The MIC2529 provides a flag output for this application.

Suspend Current

Universal Serial Bus Specification places a maximum suspend current requirement of 500 μ A on devices. For hubs, *Universal Serial Bus Specification Revision 1.1* clarifies this issue. Revision 1.1, section 7.2.3, stipulates that the maximum suspend current for a configured hub is 2.5mA.

This number is derived by allocating 500 μ A for up to four downstream ports plus 500 μ A for the hub's internal functions. A nonconfigured hub is considered a low-power device and cannot consume more than 500 μ A. In a nonconfigured state all downstream devices will be switched off. In most cases, a nonconfigured hub is not a practical state for the system. Therefore, the 2.5mA specification is the applicable target specification for the suspend state. In a bus-powered hub with less than 4 ports, the hub may use the additional current for internal functions.

The 500 μ A worst-case suspend current must be further divided among the data port termination resistors and internal functions. The termination resistors will consume $3.6V \div (16.5k\Omega - 5\%) = 230\mu A$ worst case. This leaves only 270 μ A for internal functions. Assuming 100 μ A as the maximum USB controller suspend current, 170 μ A remains for the rest of the system. The MIC2529 will consume 150 μ A maximum, leaving a margin of 20 μ A.

USB Voltage Regulation

USB specifications require a minimum downstream voltage supply of 4.40V from a bus-powered hub port (see *Application Note 17* for details). The USB specification allows for a 100mV drop across the hub, leaving 250mV for PCB, upstream cable, and connector resistance. Therefore, the on-resistance of the switch for each port, not including PCB resistance, must be about $100mV \div 100mA = 1\Omega$. For a 4-port ganged hub, this resistance reduces to 250m Ω . The MIC2529 easily satisfies this requirement.

Package Information

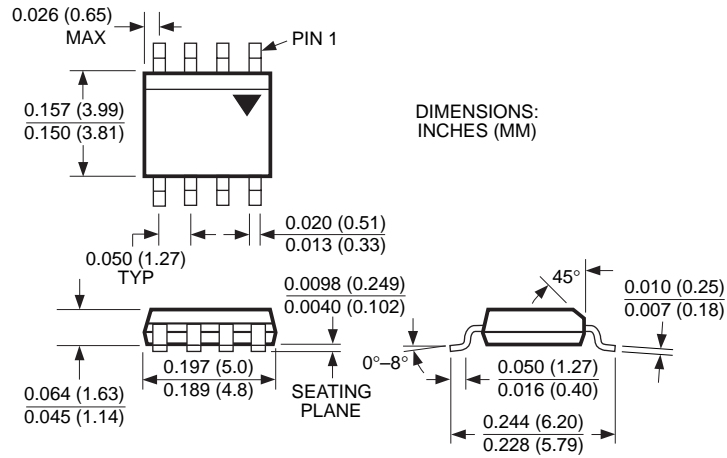

8-Pin SOIC (M)