

### General Description

The MIC2753 and MIC2754 are ultraminiature, full-featured, power supply supervisors featuring active-high and active-low reset outputs, respectively.

The MIC2753/4 includes an undervoltage detector with a power-on reset generator and reset output, an overvoltage detector with a separate output for activating crowbar circuits, and a debounced manual reset input. Typical supply current is a low 30 $\mu$ A.

These devices provide a 140ms minimum reset output at power-on and assert their reset outputs any time the input voltage deviates beyond preset overvoltage or undervoltage thresholds. Reset outputs remain asserted for 140ms (minimum) after the input returns to normal or after releasing the manual reset. When an overvoltage condition is detected, the overvoltage output is immediately activated. Hysteresis on both thresholds prevents erratic operation due to noise.

### Features

- Undervoltage and overvoltage monitor
- Separate overvoltage flag output
- Generates 140ms (minimum) power-on reset pulse
- Debounced manual reset input
- Choice of active-high (MIC2753) or active-low (MIC2754) reset outputs
- Low 30 $\mu$ A typical supply current
- No external components needed
- IttyBitty™ SOT-23-5 package

### Applications

- Computer systems
- Embedded controllers
- Power supplies
- Telecommunications systems

### Typical Application

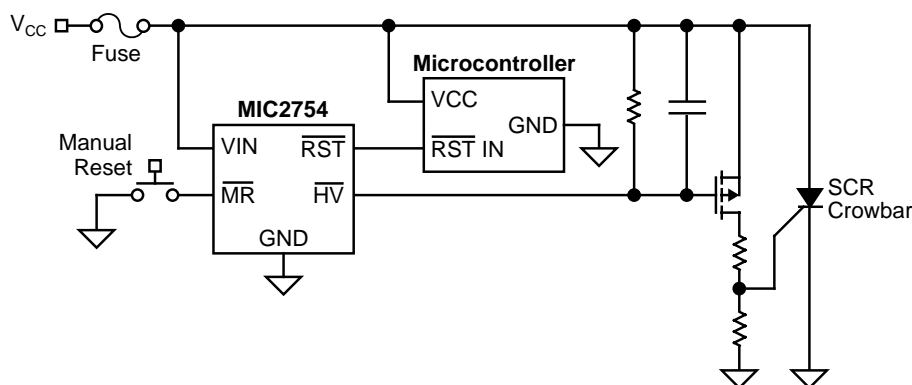

## Ordering Information

Part Number	Mark	Lower Threshold Voltage	Monitored Voltage*	Upper Threshold Voltage	Reset	Temperature Range	Package
MIC2753-RBM5	UDR	2.63V	2.85V±5%	3.08V	Active High	-40°C to +85°C	SOT-23-5
MIC2753-SBM5	UDS	2.93V	3.3V±10%	3.83V	Active High	-40°C to +85°C	SOT-23-5
MIC2753-TBM5	UDT	3.08V	3.3V±5%	3.53V	Active High	-40°C to +85°C	SOT-23-5
MIC2753-MBM5	UDM	4.38V	5.0V±10%	5.81V	Active High	-40°C to +85°C	SOT-23-5
MIC2753-LBM5	UDL	4.63V	5.0V±5%	5.38V	Active High	-40°C to +85°C	SOT-23-5
MIC2754-RBM5	UER	2.63V	2.85V±5%	3.08V	Active Low	-40°C to +85°C	SOT-23-5
MIC2754-SBM5	UES	2.93V	3.3V±10%	3.83V	Active Low	-40°C to +85°C	SOT-23-5
MIC2754-TBM5	UET	3.08V	3.3V±5%	3.53V	Active Low	-40°C to +85°C	SOT-23-5
MIC2754-MBM5	UEM	4.38V	5.0V±10%	5.81V	Active Low	-40°C to +85°C	SOT-23-5
MIC2754-LBM5	UEL	4.63V	5.0V±5%	5.38V	Active Low	-40°C to +85°C	SOT-23-5

\* Contact factory for voltages not listed.

## Pin Configuration

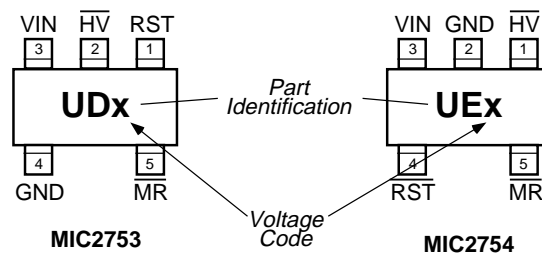

## Pin Description

Pin No. MIC2753	Pin No. MIC2754	Pin Name	Pin Function
1		RST	Reset (Digital Output): Active-high output. Asserted when $V_{IN}$ falls below $V_{THU}$ (undervoltage threshold), or rises above $V_{THO}$ (overvoltage threshold). Deasserted no less than 140ms after $V_{IN}$ returns within threshold limits.
2	1	/HV	High-Voltage Flag (Open-Drain Output): /HV is asserted (active low) when the input voltage exceeds the $V_{THO}$ (overvoltage threshold). It indicates power supply overvoltage and is intended for connection to a protection device such as a "crowbar" circuit.
3	3	VIN	Analog Input: Voltage monitor input and power supply input to the IC.
	4	/RST	Reset (Digital Output): Active-low digital output. This output will be asserted whenever $V_{IN}$ falls below $V_{THU}$ (undervoltage threshold), or rises above $V_{THO}$ (overvoltage threshold). It will be deasserted no less than 140ms after $V_{IN}$ returns within the threshold limits.
4	2	GND	Ground: Ground return for all IC functions.
5	5	/MR	Manual Reset (Digital Input): Logic low initiates immediate, unconditional reset. If $V_{IN}$ is within tolerance thresholds, when /MR is released (returns high), the reset output(s) will be deasserted no less than 140ms later. /MR may be driven by a CMOS or TTL logic signal or a mechanical switch. (Switch debouncing is performed internally.) /MR has an internal pull-up to VIN and may remain open if unused.

**Absolute Maximum Ratings (Note 1)**

Supply Voltage ( $V_{IN}$ )	−0.3V to 10V
Reset Voltage ( $V_{RST}$ )	−0.3V to $V_{IN} + 0.3V$
Manual Reset Voltage ( $V_{MR}$ )	−0.3V to $V_{IN} + 0.3V$
Reset Current ( $I_{RST}$ )	10mA
Continuous Power Dissipation ( $P_D$ at $T_A = +85^\circ C$ )	200mW
Storage Temperature ( $T_S$ )	−65°C to +150°C
ESD Rating, <b>Note 3</b>	

**Operating Ratings (Note 2)**

Supply Voltage ( $V_{IN}$ )	1.5V to 7V
Ambient Temperature ( $T_A$ )	−40°C to +85°C
Junction Temperature ( $T_J$ )	150°C
Manual Reset ( $V_{MR}$ )	0V to $V_{IN}$
Thermal Resistance ( $\theta_{JA}$ )	325°C/W

**Electrical Characteristics**

$V_{IN} = 5.0V$  (L, M voltage code),  $V_{IN} = 3.3V$  (T, S voltage code),  $V_{IN} = 2.85V$  (R voltage code)  $T_A = 25^\circ C$ ;  
**bold** values indicate  $1.5V \leq V_{IN} \leq 7.0V$ ,  $-40^\circ C \leq T_A \leq +85^\circ C$  **Note 4**; unless noted

Symbol	Parameter	Condition	Min	Typ	Max	Units
$V_{IN}$	Input Supply Voltage		<b>1.0</b>		<b>7.0</b>	V
$I_{DD}$	Operating Supply Current	manual reset not asserted		30	<b>100</b>	$\mu A$
$V_{THO}$	Overvoltage Threshold	L voltage code	<b>5.28</b>	5.38	<b>6.00</b>	V
		M voltage code	<b>5.62</b>	5.81	<b>6.00</b>	V
		T voltage code	<b>3.459</b>	3.53	<b>3.96</b>	V
		S voltage code	<b>3.67</b>	3.83	<b>3.96</b>	V
		R voltage code	<b>3.018</b>	3.08	<b>3.28</b>	V
$V_{THU}$	Undervoltage Threshold	L voltage code	<b>4.50</b>	4.63	<b>4.75</b>	V
		M voltage code	<b>4.25</b>	4.38	<b>4.50</b>	V
		T voltage code	<b>3.00</b>	3.08	<b>3.15</b>	V
		S voltage code	<b>2.85</b>	2.93	<b>3.00</b>	V
		R voltage code	<b>2.55</b>	2.63	<b>2.70</b>	V
$V_{HYST+}$	Overvoltage Threshold Hysteresis			−15		mV
$V_{HYST-}$	Undervoltage Threshold Hysteresis			+15		mV
$t_{PROP(RST)}$	Propagation Delay	$V_{IN} = V_{THO (min)} - 100mV$ to $V_{THO (max)} + 100mV$		12	<b>30</b>	$\mu s$
		$V_{IN} = V_{THU (max)} + 100mV$ to $V_{THU (min)} - 100mV$		12	<b>30</b>	$\mu s$
$t_{RST}$	Reset Pulse Width		<b>140</b>	240	<b>560</b>	ms

Symbol	Parameter	Condition	Min	Typ	Max	Units
$V_{OL(RST)}$	Reset Output Voltage Low MIC2753	R/S/T voltage codes, $V_{IN} = V_{THU(max)} + 100mV$ , $I_{SINK} = 50\mu A$			<b>0.5</b>	V
		L/M voltage codes, $V_{IN} = V_{THU(max)} + 100mV$ , $I_{SINK} = 50\mu A$			<b>0.5</b>	V
$V_{OH(RST)}$	Reset Output Voltage High MIC2753	R/S/T voltage codes, $V_{IN} = V_{THU(min)} - 100mV$ , $I_{SOURCE} = 0.5mA$	$V_{IN} - 0.5$			V
		L/M voltage codes, $V_{IN} = V_{THU(min)} - 100mV$ , $I_{SOURCE} = 1.0mA$	$V_{IN} - 0.8$			V
$V_{OL(RST)}$	/Reset Output Voltage Low MIC2754	R/S/T voltage codes, $V_{IN} = V_{THU(min)} - 100mV$ , $I_{SINK} = 0.5mA$			<b>0.5</b>	V
		L/M voltage codes, $V_{IN} = V_{THU(min)} - 100mV$ , $I_{SINK} = 1.0mA$			<b>0.8</b>	V
		$V_{IN} \geq 1.5V$ , $I_{OL} = 50\mu A$			<b>0.5</b>	V
$V_{OH(RST)}$	/Reset Output Voltage High MIC2754	R/S/T voltage codes, $V_{IN} = V_{THU(max)} + 100mV$ , $I_{SOURCE} = 35\mu A$	$V_{IN} - 0.5$			V
		L/M voltage codes, $V_{IN} = V_{THU(max)} + 100mV$ , $I_{SOURCE} = 35\mu A$	$V_{IN} - 0.5$			V
$V_{IH(MR)}$	/MR Input Voltage, High		<b>0.8</b> $V_{IN}$			V
$V_{IL(MR)}$	/MR Input Voltage, Low				<b>0.2</b> $V_{IN}$	V
$t_{PROP(MR)}$	Propagation Delay MIC2753	$V_{MR} \leq V_{IL}$ to $V_{RST} \geq V_{OH}$		1	<b>2</b>	$\mu s$
	Propagation Delay MIC2754	$V_{MR} \leq V_{IL}$ to $V_{RST} \leq V_{OL}$		1	<b>2</b>	$\mu s$
$t_{MR(min)}$	/MR Minimum Input Pulse Width		2.5			$\mu s$
$I_{PU}$	Pull-Up Current, /MR	$V_{MR} = 0V$		0.2	<b>2</b>	$\mu A$
$I_{IH}$	Input Current, /MR	$V_{MR} = V_{IN}$		0.01		$\mu A$
$V_{OL(HV)}$	/HV Output Voltage Low	$V_{IN} > V_{THO(max)}$ , $I_{SINK} = 0.5mA$ , R/S/T voltage codes			<b>0.5</b>	V
		$V_{IN} > V_{THO(max)}$ , $I_{SINK} = 1.0mA$ , L/M voltage codes			<b>0.8</b>	V
$t_{PROP(HV)}$	/HV Propagation Delay	$V_{IN} = V_{THO(min)} - 100mV$ to $V_{THO(max)} + 100mV$		12	<b>30</b>	$\mu s$
$I_{HV}$	/HV Leakage Current	$V_{IN} = V_{THO(min)} - 100mV$	<b>-2</b>		<b>+2</b>	$\mu A$

**Note 1.** Exceeding the absolute maximum rating may damage the device.

**Note 2.** The device is not guaranteed to function outside its operating rating.

**Note 3.** Devices are ESD sensitive. Handling precautions recommended.

**Note 4.** Final test on outgoing product is performed at  $T_A = 25^\circ C$ . Device performance over  $-40^\circ C \leq T_A \leq +85^\circ C$  is guaranteed by design.

# Typical Characteristics

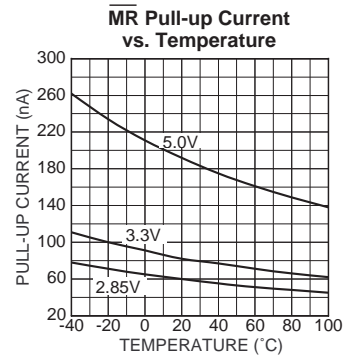
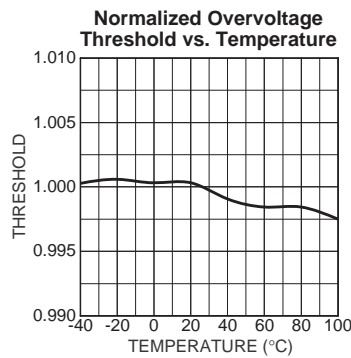
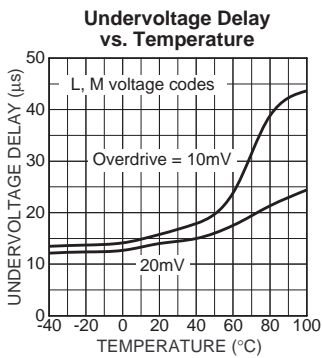
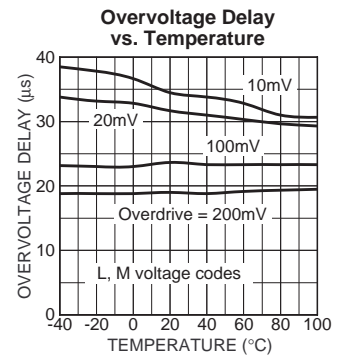
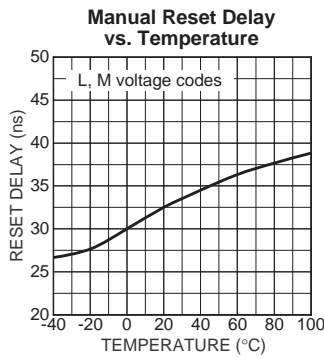
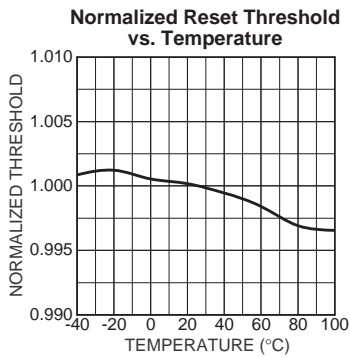
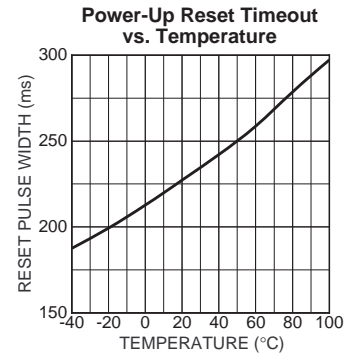
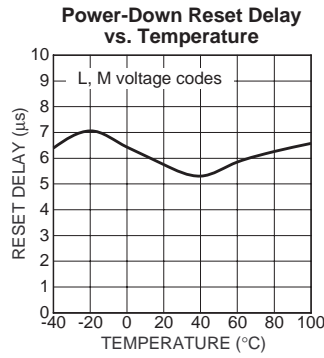
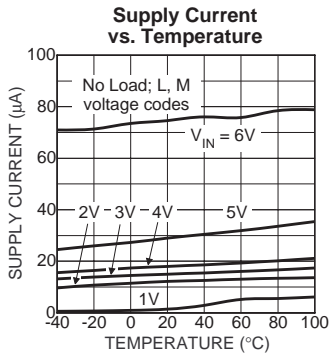

### Functional Diagram

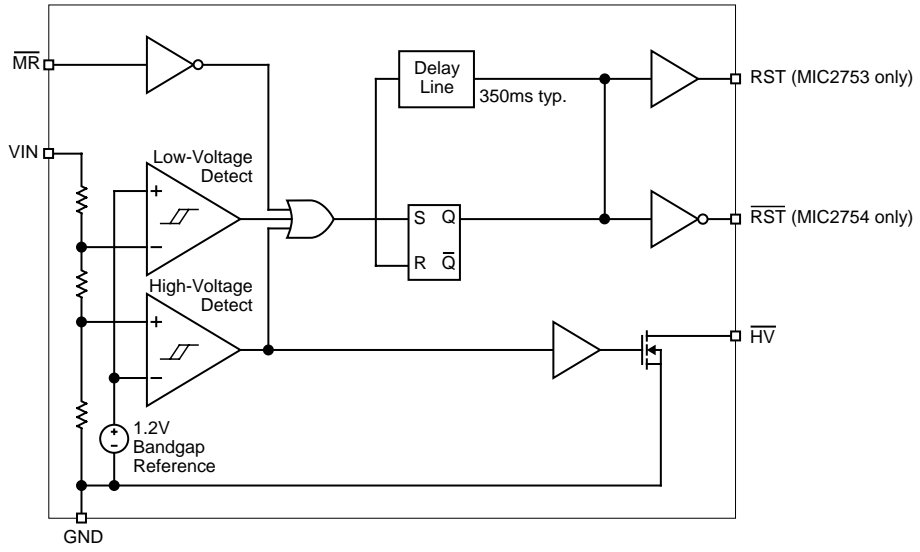

### Timing Diagram

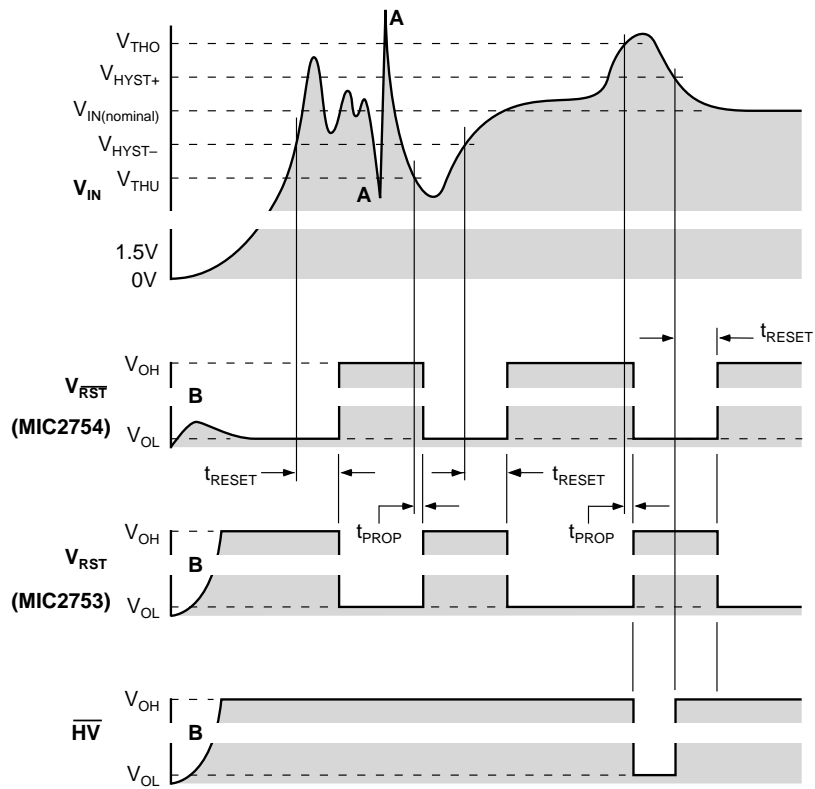

- A. Very short transients will be ignored by the MIC275x. See "Applications Information."
- B. Without external pull-down or pull-up resistors, the output is not guaranteed to be valid when  $V_{IN} < 1.5V$ .

### Manual Reset Timing

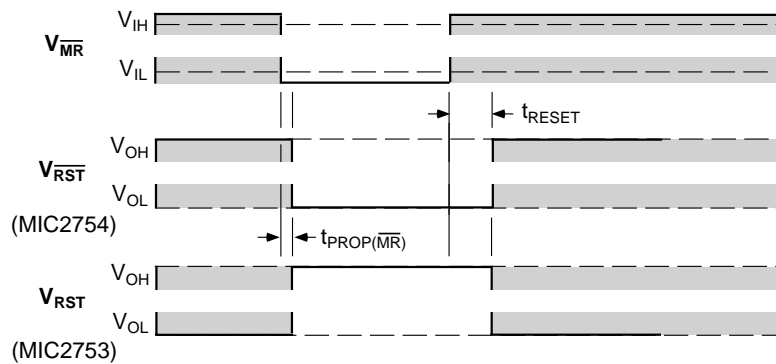

## Functional Description

The MIC275x family of devices are typically used to monitor power supplies of intelligent circuits such as microcontrollers and microprocessors. By connecting the appropriate reset output of an MIC275x to the reset input of a microcontroller or microprocessor, the processor will be properly reset at power-on, and during power-down and brownout conditions. In addition, asserting /MR (manual reset input) activates the reset function.

### Reset Outputs

The /RST and/or RST output is asserted any time /MR is asserted or if  $V_{IN}$  deviates beyond the preset threshold voltages,  $V_{THU}$  and  $V_{THO}$ . Reset output(s) remain asserted for 140ms minimum after  $V_{IN}$  returns within the threshold boundaries and/or /MR is released. A minimum 140ms reset pulse is also generated at power-on. Hysteresis is included in the overvoltage and undervoltage comparators to prevent chattering of the outputs due to noise.

The MIC275x family offers a choice of two reset output options: the MIC2753 has an active-high RST output, and the MIC2754 has an active-low /RST output.

### Manual Reset Input

The ability to initiate a reset from external logic or a manual switch is provided in addition to the MIC275x's automatic supervisory functions. Driving the /MR input low causes an immediate and unconditional reset to occur. Assuming  $V_{IN}$  is within the tolerance thresholds when /MR is released (internally pulled to logic high), the reset output will be deasserted

no less than 140ms later. /MR may be driven by a CMOS or TTL logic signal or a mechanical switch. Typically, a momentary push-button switch is connected such that /MR is shorted to ground when the contacts close. Switch debouncing is performed internally; the switch may be connected directly between /MR and GND. /MR has an internal pull-up to  $V_{IN}$  and may be left open if unused.

### Overvoltage Output

The /HV and reset outputs are immediately and unconditionally asserted any time  $V_{IN}$  exceeds  $V_{THO}$  (overvoltage threshold). /HV is an active-low, open-drain logic output. Overvoltage on a system power supply rail is generally considered to be a catastrophic condition which may cause permanent system damage. If and when an overvoltage condition occurs using a MIC275x, the system is immediately driven into reset mode and /HV (overvoltage flag), is driven active.

Typically, an overvoltage signal, such as /HV, is connected to a "crowbar circuit" using a latching power device such as an SCR. See "Typical Application". The crowbar circuit will clamp the power rail to some low voltage by shunting power supply current to ground. This should cause some upstream power supply protection device to be activated, such as fold-back current limiting, a fuse, or circuit breaker. In this way, the system is most likely to be protected against damage and spurious operation until the condition can be remedied. /HV is an open-drain output and may be wire-ORed with other open-drain logic signals. Some systems may require a pull-up resistor.

## System Block Diagram

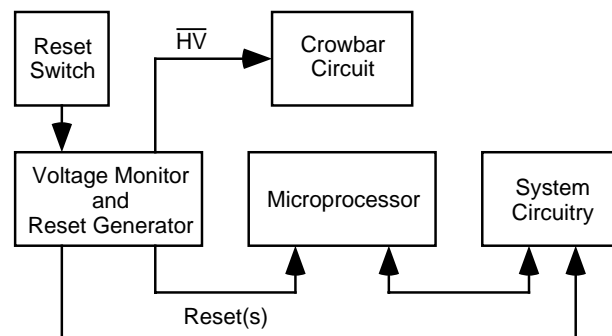



## Application Information

### Supply Transients

The MIC2753/4 are inherently immune to very short “glitches” on  $V_{IN}$ . In the case of *very brief* transients,  $V_{IN}$  may drop below the reset threshold or exceed the overvoltage threshold without activating the RST, /RST or /HV output. As shown in the graphs of Figure 1, the narrower the transient, the deeper the threshold overdrive that will be ignored by the MIC2753/4. The lines on the graph represent the typical allowable transient duration for a given amount of threshold overdrive that will not generate a reset or overvoltage indication. The data from which Figure 1 is derived was taken by adding negative-going square-wave pulses to a dc  $V_{IN}$  set at 0.5V above or below the actual measured threshold for the part being characterized.

In the case of the MIC2754L/M for example (refer to Figure 1), a transient on  $V_{IN}$  which goes below the reset threshold by 100mV and lasts no more than 8.4 $\mu$ s will typically not cause a reset to occur. Bypass capacitance placed as close as physically possible to the device’s VIN and GND pins will increase the transient immunity (0.1 $\mu$ F, for example).

### Ensuring Proper Operation at Low Supply

At levels of  $V_{IN}$  below 1.5V, the MIC2754’s /RST output driver cannot turn on sufficiently to sink current and produce a valid logic-low on the /RST output. In this situation, other CMOS circuits driven by /RST could be allowed to float, causing

undesired operation. (In most cases, however, it is expected that the circuits driven by the MIC2754 will be similarly inoperative at  $V_{CC} \leq 1.5V$ .)

If a given application requires that /RST be valid below  $V_{IN} = 1.5V$ , this can be accomplished by adding a pull-down resistor to the /RST output. A value of 100k $\Omega$  is recommended as this is usually an acceptable compromise of leakage current and pull-down current. The resistor’s value is not critical, however.

The statements above also apply to the MIC2753’s RST output. That is, to ensure valid RST signal levels at  $V_{IN} < 1.5V$ , a pull-up resistor (as opposed to a pull-down) should be added to the RST output. A value of 100k $\Omega$  is typical for this application as well. See Figure 2.

### Interfacing to Processors with Bidirectional Reset Pins

Some microcontrollers and microprocessors utilize reset signal pins that are bidirectional in nature, rather than simply being input only. The Motorola 68HC11 family is one example. To use the MIC2753/4 with these processors, it is necessary to insert a resistor into the signal path between the MIC2753/4’s reset output and the microprocessor’s reset input. This prevents excessive current from flowing due to contention between the two drivers. The signal present at the processor’s reset pin will now be of limited drive capability, so it is necessary to buffer it in order to drive other circuits. This technique is shown in Figure 3.

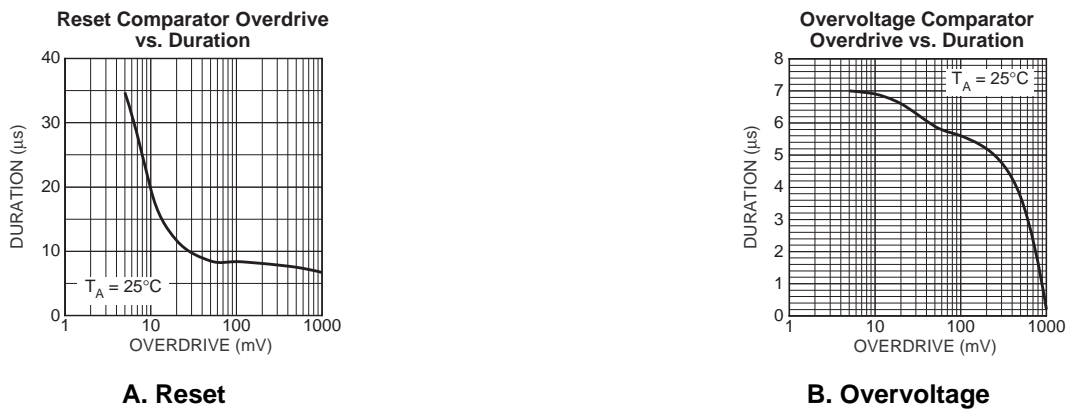

Figure 1. MIC2753/2754 Transient Immunity Behavior

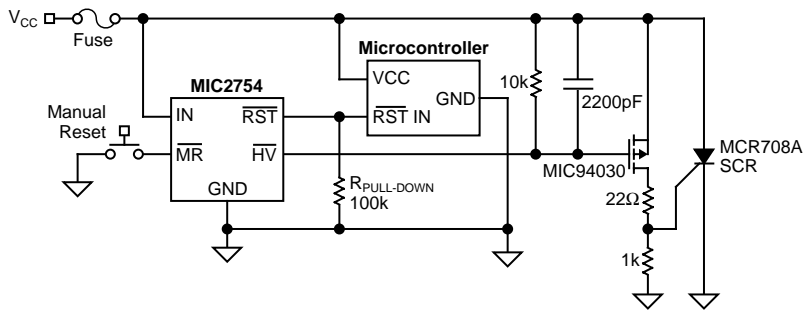

Figure 2a. MIC2754 Valid Reset Below 1.5V

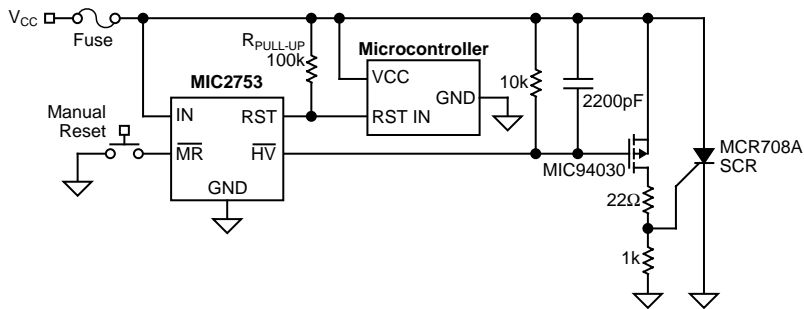

Figure 2b. MIC2753 Valid Reset Below 1.5V

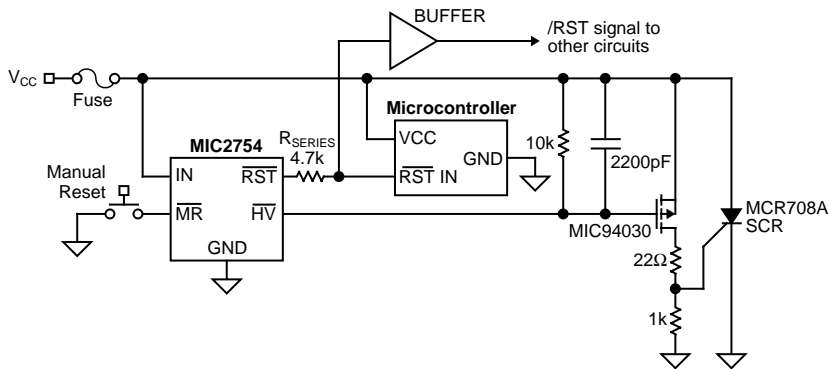

Figure 3. MIC2754 With Processors Using Bidirectional Reset Inputs.

**Crowbar Applications**

The following MIC275x applications diagrams show an SCR crowbar circuit. The function of this circuit is to protect system components from damage caused by excessive supply voltage, as might be generated by a runaway power supply. The low  $R_{DS(on)}$  of the MIC94030 P-channel MOSFET ( $<1\Omega$  at  $V_{GS} = 4.5V$ ) and the  $22\Omega$  resistor assure adequate gate current to trigger the SCR.

The crowbar circuit is designed to be functional over all operating ranges of the MIC275x. Since the lowest upper-threshold voltage of the MIC275x family is only 3.08V, and since the SCR-gate forward voltage is about 1V, there is about 90mA of gate-drive current available:  $2.08V \div 23\Omega = 0.09A$ . The highest upper-threshold voltage is 5.38V, so available gate-drive current is about 190mA:  $4.38V \div 23\Omega = 0.190A$ . The maximum forward gate current of the SCR is

200mA. The SCR trigger characteristics and the gate-drive capability provide a workable solution for the power-supply voltage range in question.

The  $10k\Omega$  resistor is the pull-up for the open-drain /HV output of the MIC275x, and the 2200pF capacitor avoids inadvertent premature triggering of the SCR, which might be caused by a very narrow spike on the /HV line. Similarly, the  $1k\Omega$  resistor from the SCR-gate to ground keeps the SCR-gate biased off.

The fuse shown in the diagrams, which ultimately protects both the system components and the crowbar SCR, should be a fast-blow type. The SCR is rated at 4A(rms), but it can withstand a brief 25A surge. The crowbar circuit shown should, conservatively, be capable of blowing a 5A or 6A fuse.

**Package Information**

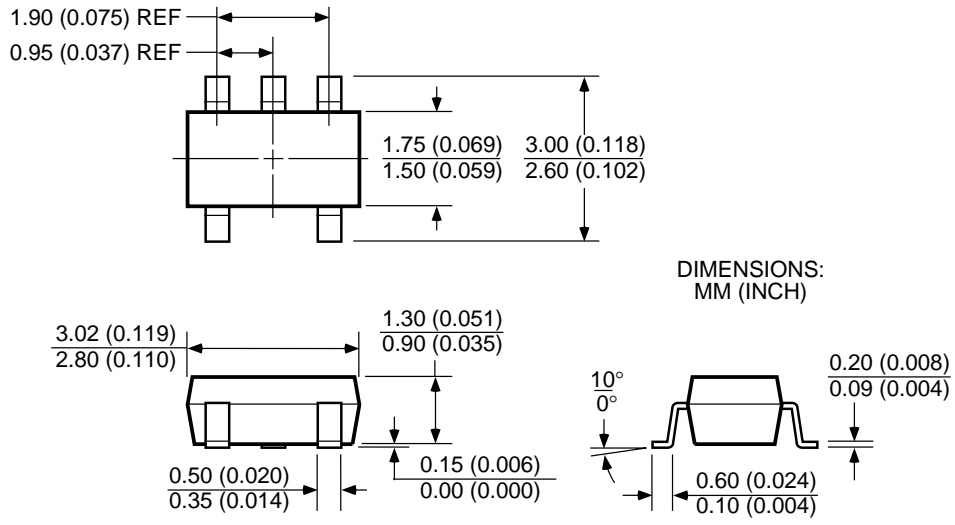

**SOT-23-5 (M5)**

---

**MICREL INC. 1849 FORTUNE DRIVE SAN JOSE, CA 95131 USA**

TEL + 1 (408) 944-0800 FAX + 1 (408) 944-0970 WEB <http://www.micrel.com>

This information is believed to be accurate and reliable, however no responsibility is assumed by Micrel for its use nor for any infringement of patents or other rights of third parties resulting from its use. No license is granted by implication or otherwise under any patent or patent right of Micrel Inc.

© 1999 Micrel Incorporated