

**FEATURES**

- 700MHz min. shift frequency
- Extended 100E VEE range of -4.2V to -5.5V
- 9 bits wide for byte-parity applications
- Asynchronous Master Reset
- Dual clocks
- Fully compatible with industry standard 10KH, 100K ECL levels
- Internal 75KΩ input pulldown resistors
- Fully compatible with Motorola MC10E/100E142
- Available in 28-pin PLCC package

**DESCRIPTION**

The SY10/100E142 are high-speed 9-bit shift registers designed for use in new, high-performance ECL systems. The E142 can accept serial or parallel data to be shifted out in one direction as both serial and parallel outputs. The nine inputs, D<sub>0</sub>-D<sub>8</sub>, accept parallel input data, while S-IN accepts serial input data.

The SEL (Select) control pin serves to determine the mode of operation, either SHIFT or LOAD. The shift direction is from bit 0 to bit 8. The input data has to meet the set-up time before being clocked into the nine input registers on the rising edge of CLK<sub>1</sub> or CLK<sub>2</sub>. Shifting is also performed on the rising edge of either CLK<sub>1</sub> or CLK<sub>2</sub>. The MR (Master Reset) control signal asynchronously resets all nine registers to a logic LOW when a logic HIGH is applied to MR.

The E142 is designed for applications such as diagnostic scan registers, parallel-to-serial conversions and is also suitable for byte-wide parity.

**BLOCK DIAGRAM**

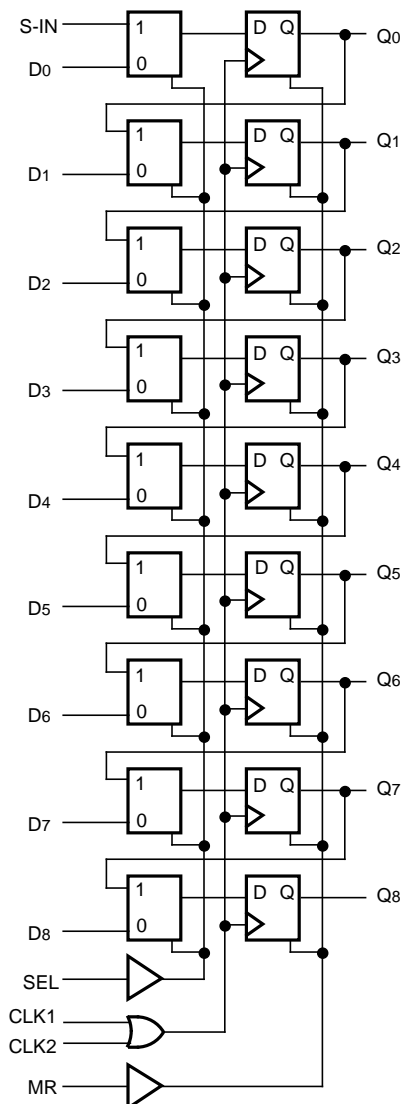

**PIN CONFIGURATION**

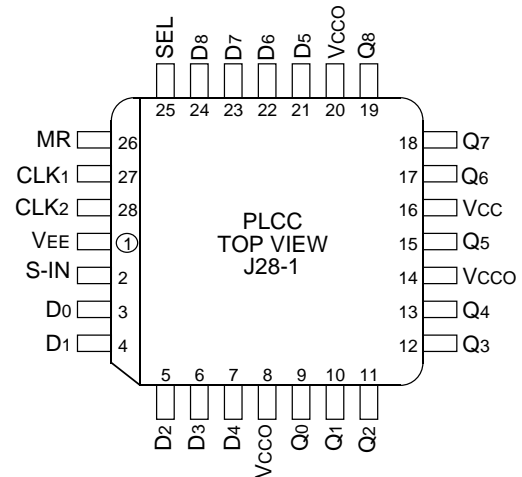

**PIN NAMES**

Pin	Function
D <sub>0</sub> -D <sub>8</sub>	Parallel Data Inputs
S-IN	Serial Data Input
SEL	Mode Select Input
CLK <sub>1</sub> , CLK <sub>2</sub>	Clock Inputs
MR	Master Reset
Q <sub>0</sub> -Q <sub>8</sub>	Data Outputs
V <sub>CCO</sub>	V <sub>CC</sub> to Output

**TRUTH TABLE**

SEL	MODE
L	LOAD
H	SHIFT

**DC ELECTRICAL CHARACTERISTICS**V<sub>EE</sub> = V<sub>EE</sub> (Min.) to V<sub>EE</sub> (Max.); V<sub>CC</sub> = V<sub>CC0</sub> = GND

Symbol	Parameter	T <sub>A</sub> = 0°C			T <sub>A</sub> = +25°C			T <sub>A</sub> = +85°C			Unit	Condition
		Min.	Typ.	Max.	Min.	Typ.	Max.	Min.	Typ.	Max.		
I <sub>IH</sub>	Input HIGH Current	—	—	150	—	—	150	—	—	150	μA	—
I <sub>EE</sub>	Power Supply Current	—	—	—	—	—	—	—	—	—	mA	—
		10E	120	145	120	145	120	145	120	145		
		100E	120	145	120	145	138	165				

**AC ELECTRICAL CHARACTERISTICS**V<sub>EE</sub> = V<sub>EE</sub> (Min.) to V<sub>EE</sub> (Max.); V<sub>CC</sub> = V<sub>CC0</sub> = GND

Symbol	Parameter	T <sub>A</sub> = 0°C			T <sub>A</sub> = +25°C			T <sub>A</sub> = +85°C			Unit	Condition
		Min.	Typ.	Max.	Min.	Typ.	Max.	Min.	Typ.	Max.		
f <sub>SHIFT</sub>	Max. Shift Frequency	700	900	—	700	900	—	700	900	—	MHz	—
t <sub>PLH</sub> t <sub>PHL</sub>	Propagation Delay to Output CLK MR	600 600	800 800	1000 1000	600 600	800 800	1000 1000	600 600	800 800	1000 1000	ps	—
t <sub>s</sub>	Set-up Time D SEL	50 300	-100 150	— —	50 300	-100 150	— —	50 300	-100 150	— —	ps	—
		300 75	100 -150	— —	300 75	100 -150	— —	300 75	100 -150	— —	ps	—
t <sub>RR</sub>	Reset Recovery Time	900	700	—	900	700	—	900	700	—	ps	—
t <sub>PW</sub>	Minimum Pulse Width CLK, MR	400	—	—	400	—	—	400	—	—	ps	—
t <sub>skew</sub>	Within-Device Skew	—	75	—	—	75	—	—	75	—	ps	1
t <sub>r</sub> t <sub>f</sub>	Rise/Fall Time 20% to 80%	300	525	800	300	525	800	300	525	800	ps	—

**NOTE:**

1. Within-device skew is defined as identical transitions on similar paths through a device.

**PRODUCT ORDERING CODE**

Ordering Code	Package Type	Operating Range
SY10E142JC	J28-1	Commercial
SY10E142JCTR	J28-1	Commercial
SY100E142JC	J28-1	Commercial
SY100E142JCTR	J28-1	Commercial

**28 LEAD PLCC (J28-1)**

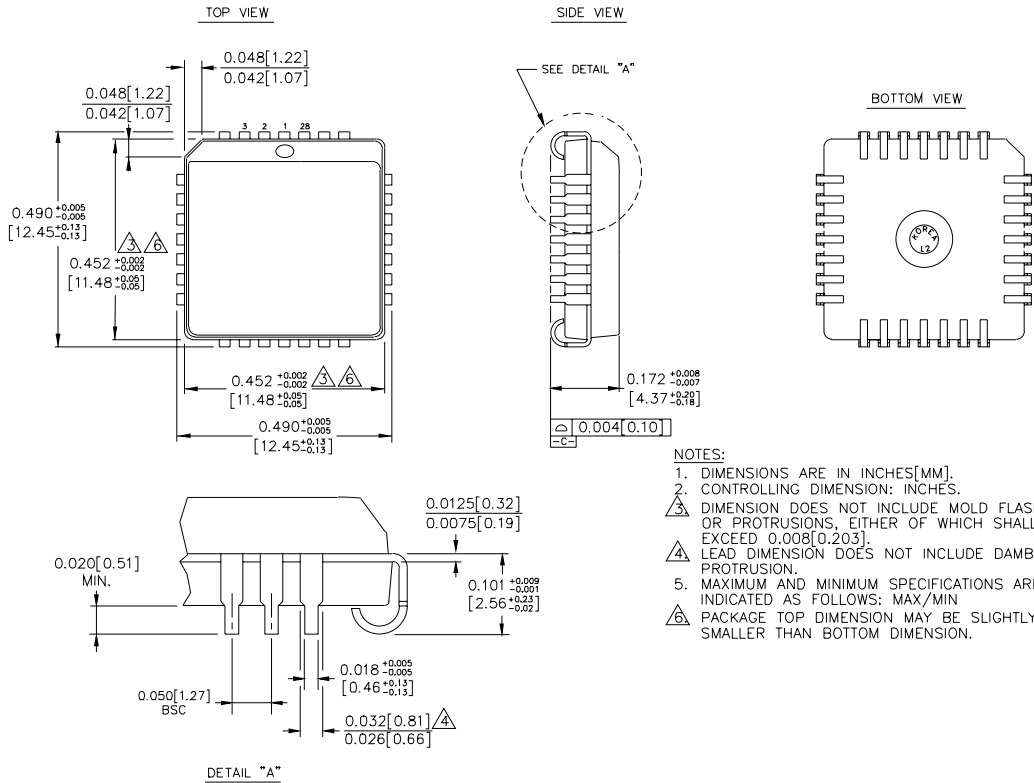

- NOTES:
1. DIMENSIONS ARE IN INCHES[MM].
  2. CONTROLLING DIMENSION: INCHES.
  3. DIMENSION DOES NOT INCLUDE MOLD FLASH OR PROTRUSIONS, EITHER OF WHICH SHALL NOT EXCEED 0.008[0.203].
  4. LEAD DIMENSION DOES NOT INCLUDE DAMBAR PROTRUSION.
  5. MAXIMUM AND MINIMUM SPECIFICATIONS ARE INDICATED AS FOLLOWS: MAX/MIN
  6. PACKAGE TOP DIMENSION MAY BE SLIGHTLY SMALLER THAN BOTTOM DIMENSION.

Rev. 03

---

**MICREL-SYNERGY 3250 SCOTT BOULEVARD SANTA CLARA CA 95054 USA**

TEL + 1 (408) 980-9191 FAX + 1 (408) 914-7878 WEB <http://www.micrel.com>

This information is believed to be accurate and reliable, however no responsibility is assumed by Micrel for its use nor for any infringement of patents or other rights of third parties resulting from its use. No license is granted by implication or otherwise under any patent or patent right of Micrel Inc.

© 2000 Micrel Incorporated

---