

FEATURES

- Differential D, CLK and Q
- Extended 100E VEE range of -4.2V to -5.5V
- VBB output for single-ended use
- 1100MHz min. toggle frequency
- Asynchronous Master Reset
- Fully compatible with Motorola MC10E/100E452
- Available in 28-pin PLCC package

DESCRIPTION

The SY10/100E452 are 5-bit differential registers with differential data (inputs and outputs) and clock. The registers are triggered by a positive transition of the positive clock (CLK) input. A high on the Master Reset (MR) asynchronously resets all registers so that the Q outputs go LOW.

The differential input structures are clamped so that the inputs of unused registers can be left open without upsetting the bias network of the devices. The clamping action will assert the /D and the /CLK sides of the inputs. Because of the edge-triggered flip-flop nature of the devices, simultaneously opening both the clock and data inputs will result in an output which reaches an unidentified but valid state.

The fully differential design of the devices makes them ideal for very high frequency applications where a registered data path is necessary.

BLOCK DIAGRAM

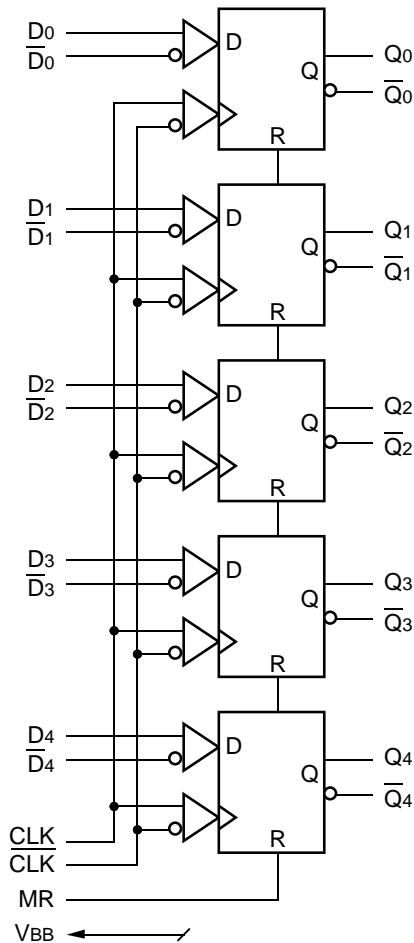

PIN CONFIGURATION

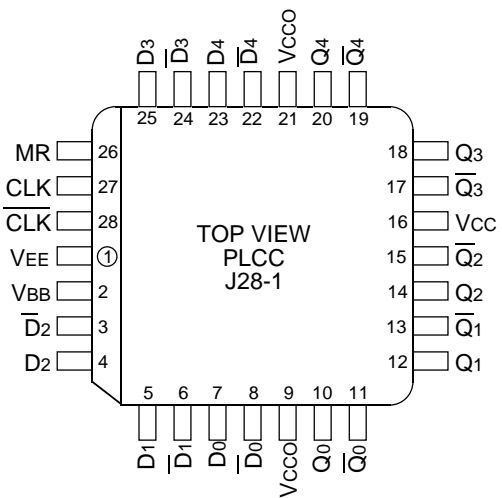

PIN NAMES

Pin	Function
D [0:4], /D [0:4]	Differential Data Inputs
MR	Master Reset Input
CLK, /CLK	Differential Clock Input
VBB	VBB Reference Output
Q [0:4], Q [0:4]	Differential Data Outputs
VCCO	Vcc to Output

DC ELECTRICAL CHARACTERISTICS

VEE = VEE (Min.) to VEE (Max.); VCC = VCCO = GND

Symbol	Parameter	TA = -40°C			TA = 0°C			TA = +25°C			TA = +85°C			Unit	
		Min.	Typ.	Max.	Min.	Typ.	Max.	Min.	Typ.	Max.	Min.	Typ.	Max.		
VBB	Output Reference Voltage	10E	-1.43	—	-1.30	-1.38	—	-1.27	-1.35	—	-1.25	-1.31	—	-1.19	V
		100E	-1.38	—	-1.26	-1.38	—	-1.26	-1.38	—	-1.26	-1.38	—	-1.26	
I _{IH}	Input HIGH Current	—	—	150	—	—	150	—	—	150	—	—	150	μA	
I _{EE}	Power Supply Current	10E	—	74	89	—	74	89	—	74	89	—	74	89	mA
		100E	—	74	89	—	74	89	—	74	89	—	85	102	
V _{CMR}	Common Mode Range ⁽¹⁾	-2.0	—	-0.4	-2.0	—	-0.4	-2.0	—	-0.4	-2.0	—	-0.4	V	

NOTE:

- V_{CMR} is referenced to the most positive side of the differential input signal. Normal operation is obtained when the input signals are within the V_{CMR} range and the input swing is greater than V_{PP} (min.) and <1V.

AC ELECTRICAL CHARACTERISTICS

VEE = VEE (Min.) to VEE (Max.); VCC = VCCO = GND

Symbol	Parameter	TA = -40°C			TA = 0°C			TA = +25°C			TA = +85°C			Unit													
		Min.	Typ.	Max.	Min.	Typ.	Max.	Min.	Typ.	Max.	Min.	Typ.	Max.														
f _{MAX}	Max. Toggle Frequency	1000	1400	—	1100	1400	—	1100	1400	—	1100	1400	—	MHz													
t _{PLH}	Propagation Delay to Output	425	600	850	475	600	800	475	600	800	475	600	800	ps													
t _{PHL}															CLK (Diff)	375	600	900	425	600	850	425	600	850	425	600	850
															CLK (SE) MR	375	625	900	425	625	850	425	625	850	425	625	850
t _S	Set-up Time, D	175	-50	—	150	-50	—	150	-50	—	150	-50	—	ps													
t _H	Hold Time, D	225	50	—	200	50	—	200	50	—	200	50	—	ps													
t _{RR}	Reset Recovery Time	750	450	—	700	450	—	700	450	—	700	450	—	ps													
t _{PW}	Minimum Pulse Width	400	—	—	400	—	—	400	—	—	400	—	—	ps													
															CLK	400	—	—	400	—	—	400	—	—	400	—	—
	MR	400	—	—	400	—	—	400	—	—	400	—	—														
t _{skew}	Within-Device Skew ⁽¹⁾	—	50	—	—	50	—	—	50	—	—	50	—	ps													
V _{PP (AC)}	Minimum Input Swing ⁽²⁾	150	—	—	150	—	—	150	—	—	150	—	—	mV													
t _r	Rise/Fall Time	250	475	725	275	475	675	275	475	675	275	475	675	ps													
t _f															20–80%												

NOTES:

- Within-device skew is defined as identical transitions on similar paths through a device.
- Minimum input swing for which AC parameters are guaranteed.

PRODUCT ORDERING CODE

Ordering Code	Package Type	Operating Range
SY10E452JC	J28-1	Commercial
SY10E452JCTR	J28-1	Commercial
SY100E452JC	J28-1	Commercial
SY100E452JCTR	J28-1	Commercial

Ordering Code	Package Type	Operating Range
SY10E452JI	J28-1	Industrial
SY10E452JITR	J28-1	Industrial
SY100E452JI	J28-1	Industrial
SY100E452JITR	J28-1	Industrial

28 LEAD PLCC (J28-1)

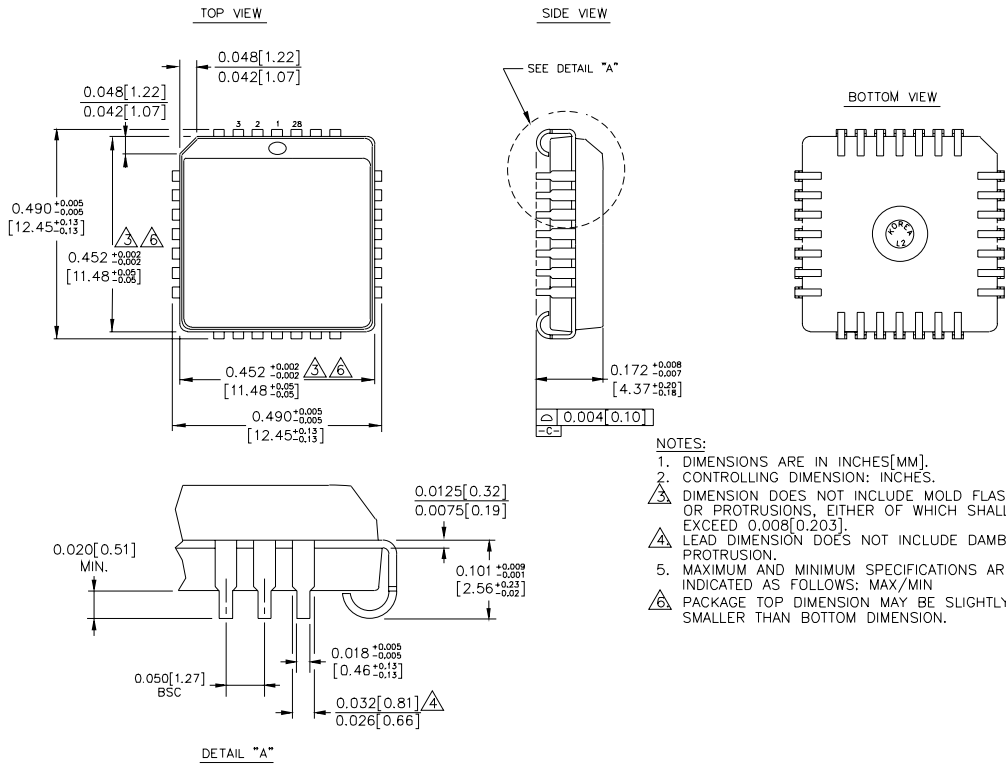

- NOTES:**
1. DIMENSIONS ARE IN INCHES[MM].
 2. CONTROLLING DIMENSION: INCHES.
 3. DIMENSION DOES NOT INCLUDE MOLD FLASH OR PROTRUSIONS, EITHER OF WHICH SHALL NOT EXCEED 0.008[0.203].
 4. LEAD DIMENSION DOES NOT INCLUDE DAMBAR PROTRUSION.
 5. MAXIMUM AND MINIMUM SPECIFICATIONS ARE INDICATED AS FOLLOWS: MAX/MIN
- PACKAGE TOP DIMENSION MAY BE SLIGHTLY SMALLER THAN BOTTOM DIMENSION.

Rev. 03

MICREL-SYNERGY 3250 SCOTT BOULEVARD SANTA CLARA CA 95054 USA

TEL + 1 (408) 980-9191 FAX + 1 (408) 914-7878 WEB <http://www.micrel.com>

This information is believed to be accurate and reliable, however no responsibility is assumed by Micrel for its use nor for any infringement of patents or other rights of third parties resulting from its use. No license is granted by implication or otherwise under any patent or patent right of Micrel Inc.

© 2000 Micrel Incorporated
