

FEATURES

- 230ps propagation delay
- High bandwidth output transitions
- Internal 75KΩ input pull-down resistors
- Available in 8-pin SOIC package

DESCRIPTION

The SY10/100EL01 are 4-input OR/NOR gates. These devices are functionally equivalent to the E101 devices, with higher performance capabilities. With propagation delays and output transition times significantly faster than the E101, the EL01 is ideally suited for those applications which require the ultimate in AC performance.

PIN CONFIGURATION/BLOCK DIAGRAM

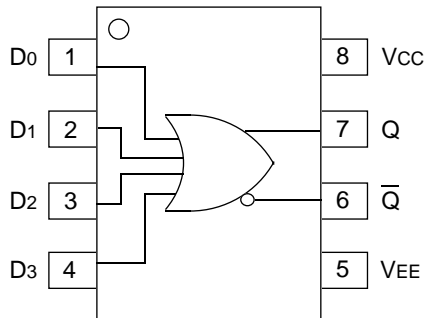

**SOIC
TOP VIEW**

PIN NAMES

Pin	Function
D0-D3	Data Inputs
Q	Data Outputs

DC ELECTRICAL CHARACTERISTICSV_{EE} = V_{EE} (Min.) to V_{EE} (Max.); V_{CC} = GND

Symbol	Parameter	T _A = -40°C			T _A = 0°C			T _A = +25°C			T _A = +85°C			Unit
		Min.	Typ.	Max.	Min.	Typ.	Max.	Min.	Typ.	Max.	Min.	Typ.	Max.	
I _{EE}	Power Supply Current													mA
	10EL	—	14	17	11	14	17	11	14	17	11	14	17	
	100EL	—	14	17	11	14	17	11	14	17	13	16	20	
V _{EE}	Power Supply Voltage													V
	10EL	-4.75	-5.2	-5.5	-4.75	-5.2	-5.5	-4.75	-5.2	-5.5	-4.75	-5.2	-5.5	
	100EL	-4.20	-4.5	-5.5	-4.20	-4.5	-5.5	-4.20	-4.5	-5.5	-4.20	-4.5	-5.5	
I _{IH}	Input HIGH Current	—	—	150	—	—	150	—	—	150	—	—	150	μA

AC ELECTRICAL CHARACTERISTICSV_{EE} = V_{EE} (Min.) to V_{EE} (Max.); V_{CC} = GND

Symbol	Parameter	T _A = -40°C			T _A = 0°C			T _A = +25°C			T _A = +85°C			Unit
		Min.	Typ.	Max.	Min.	Typ.	Max.	Min.	Typ.	Max.	Min.	Typ.	Max.	
t _{PLH} t _{PHL}	Propagation Delay to Output D	70	220	370	120	220	320	130	230	330	150	250	350	ps
t _r t _f	Output Rise/Fall Times Q (20% to 80%)	70	225	350	100	225	350	100	225	350	100	225	350	ps

PRODUCT ORDERING CODE

Ordering Code	Package Type	Operating Range
SY10EL01ZC	Z8-1	Commercial
SY10EL01ZCTR	Z8-1	Commercial
SY100EL01ZC	Z8-1	Commercial
SY100EL01ZCTR	Z8-1	Commercial

8 LEAD SOIC .150" WIDE (Z8-1)

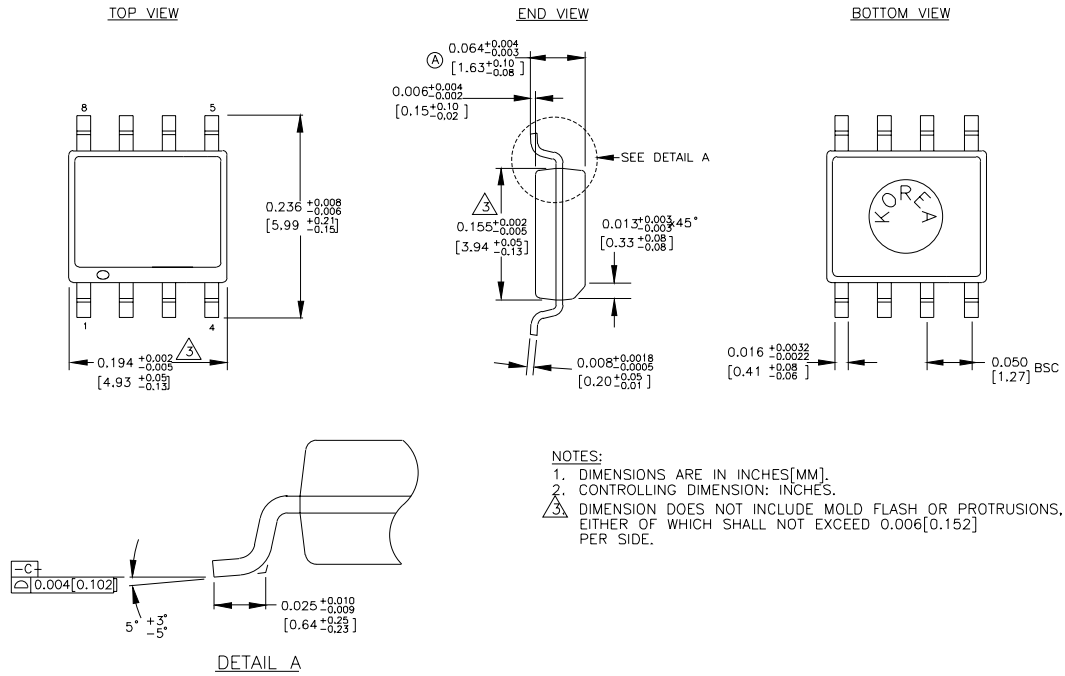

Rev. 03

MICREL-SYNERGY 3250 SCOTT BOULEVARD SANTA CLARA CA 95054 USA

TEL + 1 (408) 980-9191 FAX + 1 (408) 914-7878 WEB <http://www.micrel.com>

This information is believed to be accurate and reliable, however no responsibility is assumed by Micrel for its use nor for any infringement of patents or other rights of third parties resulting from its use. No license is granted by implication or otherwise under any patent or patent right of Micrel Inc.

© 2000 Micrel Incorporated
