

**FEATURES**

- 525ps propagation delay
- 2.2GHz toggle frequency
- High bandwidth output transistions
- Internal 75KΩ input pull-down resistors
- Available in 8-pin SOIC package

**DESCRIPTION**

The SY10/100EL35 are high-speed JK Flip-Flops. The J/K data enters the master portion of the flip-flop when the clock is LOW and is transferred to the slave and, thus, the outputs, upon a positive transition of the clock. The reset pin is asynchronous and is activated with a logic HIGH.

**PIN CONFIGURATION/BLOCK DIAGRAM**

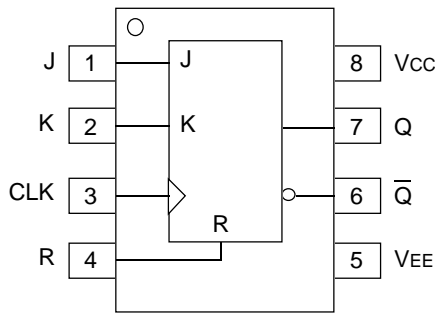

**SOIC  
TOP VIEW**

**TRUTH TABLE<sup>(1)</sup>**

J	K	R	CLK	Q <sub>n+1</sub>
L	L	L	Z	Q <sub>n</sub>
L	H	L	Z	L
H	L	L	Z	H
H	H	L	Z	$\bar{Q}_n$
X	X	H	X	L

**NOTE:**

1. Z = LOW-to-HIGH transition.

**DC ELECTRICAL CHARACTERISTICS**

VEE = VEE (Min.) to VEE (Max.); VCC = GND

Symbol	Parameter	TA = -40°C			TA = 0°C			TA = +25°C			TA = +85°C			Unit
		Min.	Typ.	Max.	Min.	Typ.	Max.	Min.	Typ.	Max.	Min.	Typ.	Max.	
IEE	Power Supply Current	—	27	32	—	27	32	—	27	32	—	27	32	mA
	10EL	—	27	32	—	27	32	—	27	32	—	27	32	
	100EL	—	27	32	—	27	32	—	27	32	—	32	37	
VEE	Power Supply Voltage	—	-5.2	—	-4.75	-5.2	-5.5	-4.75	-5.2	-5.5	-4.75	-5.2	-5.5	V
	10EL	—	-5.2	—	-4.75	-5.2	-5.5	-4.75	-5.2	-5.5	-4.75	-5.2	-5.5	
	100EL	—	-4.5	—	-4.20	-4.5	-5.5	-4.20	-4.5	-5.5	-4.20	-4.5	-5.5	
I <sub>IH</sub>	Input HIGH Current	—	—	150	—	—	150	—	—	150	—	—	150	μA

**AC ELECTRICAL CHARACTERISTICS**

VEE = VEE (Min.) to VEE (Max.); VCC = GND

Symbol	Parameter	TA = -40°C			TA = 0°C			TA = +25°C			TA = +85°C			Unit
		Min.	Typ.	Max.	Min.	Typ.	Max.	Min.	Typ.	Max.	Min.	Typ.	Max.	
f <sub>MAX</sub>	Maximum Toggle Frequency	1.4	2.0	—	1.8	2.2	—	1.8	2.2	—	1.8	2.2	—	GHz
t <sub>PLH</sub> t <sub>PHL</sub>	Propagation Delay CLK to Output	290 225	515 450	—	340 275	515 450	690 625	350 275	525 450	700 625	395 350	570 525	745 700	ps
t <sub>S</sub>	Set-up Time	150	0	—	150	0	—	150	0	—	150	0	—	ps
t <sub>H</sub>	Hold Time	250	100	—	250	100	—	250	100	—	250	100	—	ps
t <sub>RR</sub>	Reset Recovery	400	200	—	400	200	—	400	200	—	400	200	—	ps
t <sub>PW</sub>	Minimum Pulse Width CLK, Reset	400	—	—	400	—	—	400	—	—	400	—	—	ps
t <sub>r</sub> t <sub>f</sub>	Output Rise/Fall Times Q (20% to 80%)	100	225	350	100	225	350	100	225	350	100	225	350	ps

**PRODUCT ORDERING CODE**

Ordering Code	Package Type	Operating Range
SY10EL35ZC	Z8-1	Commercial
SY10EL35ZCTR	Z8-1	Commercial
SY100EL35ZC	Z8-1	Commercial
SY100EL35ZCTR	Z8-1	Commercial

**8 LEAD SOIC .150" WIDE (Z8-1)**

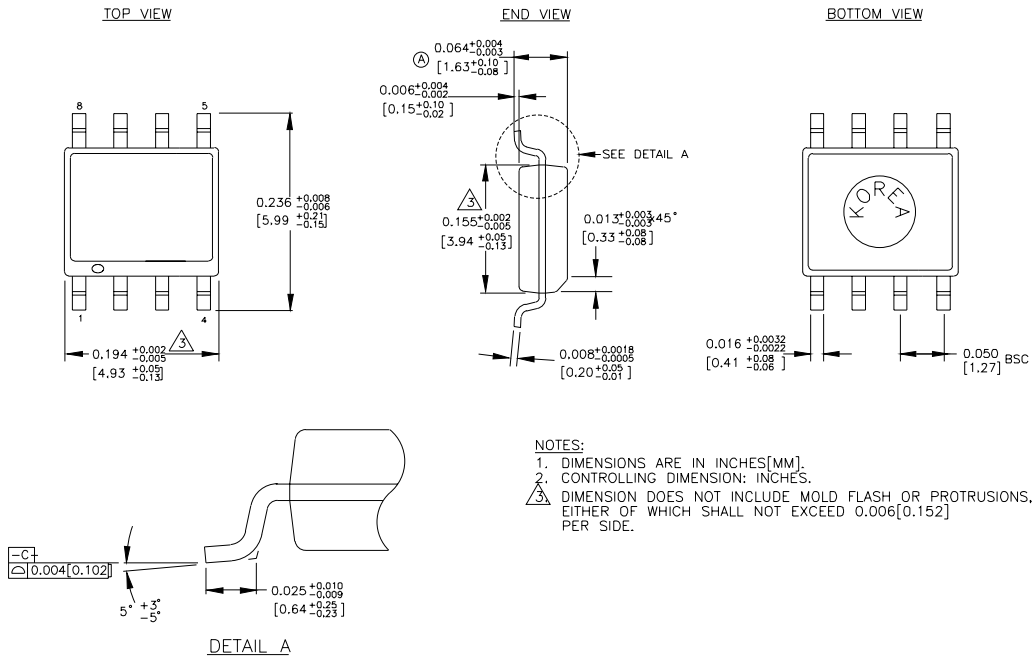

Rev. 03

---

**MICREL-SYNERGY 3250 SCOTT BOULEVARD SANTA CLARA CA 95054 USA**

TEL + 1 (408) 980-9191 FAX + 1 (408) 914-7878 WEB <http://www.micrel.com>

This information is believed to be accurate and reliable, however no responsibility is assumed by Micrel for its use nor for any infringement of patents or other rights of third parties resulting from its use. No license is granted by implication or otherwise under any patent or patent right of Micrel Inc.

© 2000 Micrel Incorporated

---