



## 128Mb: x4, x8, x16 DDR333 SDRAM Addendum

# DOUBLE DATA RATE (DDR) SDRAM

MT46V32M4 – 8 Meg x 4 x 4 banks  
 MT46V16M8 – 4 Meg x 8 x 4 banks  
 MT46V8M16 – 2 Meg x 16 x 4 banks

For the latest data sheet revisions, please refer to the Micron  
 Web site: [www.micron.com/dramds](http://www.micron.com/dramds)

### FEATURES

- 167 MHz Clock, 333 Mb/s/p data rate
- $V_{DD} = +2.5V \pm 0.2V$ ,  $V_{DDQ} = +2.5V \pm 0.2V$
- Bidirectional data strobe (DQS) transmitted/received with data, i.e., source-synchronous data capture (x16 has two - one per byte)
- Internal, pipelined double-data-rate (DDR) architecture; two data accesses per clock cycle
- Differential clock inputs (CK and CK#)
- Commands entered on each positive CK edge
- DQS edge-aligned with data for READS; center-aligned with data for WRITES
- DLL to align DQ and DQS transitions with CK
- Four internal banks for concurrent operation
- Data mask (DM) for masking write data (x16 has two - one per byte)
- Programmable burst lengths: 2, 4, or 8
- Concurrent Auto Precharge option supported
- Auto Refresh and Self Refresh Modes
- FBGA package available
- 2.5V I/O (SSTL<sub>2</sub> compatible)
- <sup>†</sup>RAS lockout (<sup>†</sup>RAP = <sup>†</sup>RCD)
- Backwards compatible with DDR200 and DDR266

### OPTIONS

- Configuration
 

32 Meg x 4 (8 Meg x 4 x 4 banks)	32M4
16 Meg x 8 (4 Meg x 8 x 4 banks)	16M8
8 Meg x 16 (2 Meg x 16 x 4 banks)	8M16
- Plastic Package
 

66-Pin TSOP (OCPL)	TG
60-Ball FBGA (16x9mm)	FJ
- Timing - Cycle Time
 

6ns @ CL = 2.5 (DDR333B-FBGA) <sup>1</sup>	-6
6ns @ CL = 2.5 (DDR333B-TSOP) <sup>1</sup>	-6T
7.5ns @ CL = 2 (DDR266A) <sup>2</sup>	-75Z
- Self Refresh
 

Standard	none
----------	------

**NOTE:** 1. Supports PC2700 modules with 2.5-3-3 timing  
 2. Supports PC2100 modules with 2-3-3 timing

### DDR333 COMPATIBILITY

DDR333 meets or surpasses all DDR266 timing requirements thus assuring full backwards compatibility with current DDR designs. In addition, these devices support concurrent auto-precharge and <sup>†</sup>RAS lockout for improved timing performance. The 128Mb, DDR333 device will support an (<sup>†</sup>REFI) average periodic refresh interval of 15.6 $\mu$ s.

The standard 66-pin TSOP package is offered for point-to-point applications where the FBGA package is intended for the multi-drop systems.

The Micron 128Mb data sheet provides full specifications and functionality unless specified herein.

### CONFIGURATION

Architecture	32 Meg x 4	16 Meg x 8	8 Meg x 16
Configuration	8 Meg x 4 x 4 banks	4 Meg x 8 x 4 banks	2 Meg x 16 x 4 banks
Refresh Count	4K	4K	4K
Row Addressing	4K (A0-A11)	4K (A0-A11)	4K (A0-A11)
Bank Addressing	4 (BA0, BA1)	4 (BA0, BA1)	4 (BA0, BA1)
Column Addressing	2K (A0-A9, A11)	1K (A0-A9)	512 (A0-A8)

### KEY TIMING PARAMETERS<sup>3</sup>

SPEED GRADE	CLOCK RATE		DATA-OUT WINDOW <sup>2</sup>	ACCESS WINDOW	DQS-DQ SKEW
	CL = 2 <sup>1</sup>	CL = 2.5 <sup>1</sup>			
-6	133 MHz	167 MHz	2.15ns	$\pm 0.70$ ns	+0.35ns
-6T	133 MHz	167 MHz	2.0ns	$\pm 0.75$ ns	+0.45ns
-75Z	133 MHz	133 MHz	2.5ns	$\pm 0.75$ ns	+0.50ns

- NOTE:**
1. CL = CAS (Read) Latency
  2. With a 50/50 clock duty cycle and a minimum clock rate @ CL = 2 (-75Z) and CL = 2.5 (-6, -6T).
  3. Slower speeds are included in the 128Mb base data sheet (-75, -8).



# 128Mb: x4, x8, x16 DDR333 SDRAM Addendum

## FBGA 60-BALL PACKAGE DIMENSION

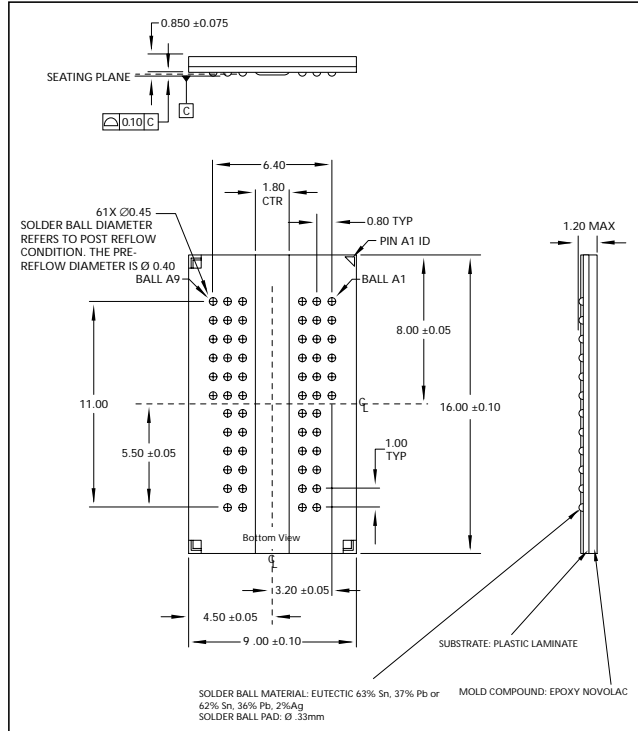

## FBGA PACKAGE MARKING

Due to the physical size of the FBGA package, the full ordering part number is not printed on the package. Instead the following package code is utilized.

Top mark contains five fields **12345**

- Field 1 (Product Family)
  - DRAM **D**
  - DRAM - ES **Z**
- Field 2 (Product Type)
  - 2.5 Volt, DDR SDRAM, 60-ball **L**
- Field 3 (Width)
  - x4 devices **B**
  - x8 devices **C**
  - x16 devices **D**
- Field 4 (Density / Size)
  - 128Mb **F**
- Field 5 (Speed Grade)
  - 6 **J**
  - 75Z **P**
  - 75 **F**
  - 8 **C**

Example top mark for a MT46V32M4FJ-6: **DLBFJ**

## FBGA PACKAGE PINOUT

x4 (Top View)												
	1	2	3	4	5	6	7	8	9			
A	VssQ	NC	Vss	●	●	●	A	VDD	NC	VDDQ		
B	NC	VDDQ	DQ3	●	●	●	B	DQ0	VssQ	NC		
C	NC	VssQ	NC	●	●	●	C	NC	VDDQ	NC		
D	NC	VDDQ	DQ2	●	●	●	D	DQ1	VssQ	NC		
E	NC	VssQ	DQS	●	●	●	E	NC	VDDQ	NC		
F	VREF	Vss	DM	●	●	●	F	NC	VDD	A13		
G		CK	CK#	●	●	●	G	WE#	CAS#			
H		A12	CKE	●	●	●	H	RAS#	CS#			
J		A11	A9	●	●	●	J	BA1	BA0			
K		A8	A7	●	●	●	K	A0	A10			
L		A6	A5	●	●	●	L	A2	A1			
M		A4	Vss	●	●	●	M	VDD	A3			

x8 (Top View)												
	1	2	3	4	5	6	7	8	9			
A	VssQ	DQ7	Vss	●	●	●	A	VDD	DQ0	VDDQ		
B	NC	VDDQ	DQ6	●	●	●	B	DQ1	VssQ	NC		
C	NC	VssQ	DQ5	●	●	●	C	DQ2	VDDQ	NC		
D	NC	VDDQ	DQ4	●	●	●	D	DQ3	VssQ	NC		
E	NC	VssQ	DQS	●	●	●	E	NC	VDDQ	NC		
F	VREF	Vss	DM	●	●	●	F	NC	VDD	A13		
G		CK	CK#	●	●	●	G	WE#	CAS#			
H		A12	CKE	●	●	●	H	RAS#	CS#			
J		A11	A9	●	●	●	J	BA1	BA0			
K		A8	A7	●	●	●	K	A0	A10			
L		A6	A5	●	●	●	L	A2	A1			
M		A4	Vss	●	●	●	M	VDD	A3			

  

x16 (Top View)												
	1	2	3	4	5	6	7	8	9			
A	VssQ	DQ15	Vss	●	●	●	A	VDD	DQ0	VDDQ		
B	DQ14	VDDQ	DQ13	●	●	●	B	DQ2	VssQ	DQ1		
C	DQ12	VssQ	DQ11	●	●	●	C	DQ4	VDDQ	DQ3		
D	DQ10	VDDQ	DQ9	●	●	●	D	DQ6	VssQ	DQ5		
E	DQ8	VssQ	UDQS	●	●	●	E	LDQS	VDDQ	DQ7		
F	VREF	Vss	UDM	●	●	●	F	LDM	VDD	A13		
G		CK	CK#	●	●	●	G	WE#	CAS#			
H		A12	CKE	●	●	●	H	RAS#	CS#			
J		A11	A9	●	●	●	J	BA1	BA0			
K		A8	A7	●	●	●	K	A0	A10			
L		A6	A5	●	●	●	L	A2	A1			
M		A4	Vss	●	●	●	M	VDD	A3			



# 128Mb: x4, x8, x16 DDR333 SDRAM Addendum

## 66-PIN TSOP PACKAGE DIMENSION

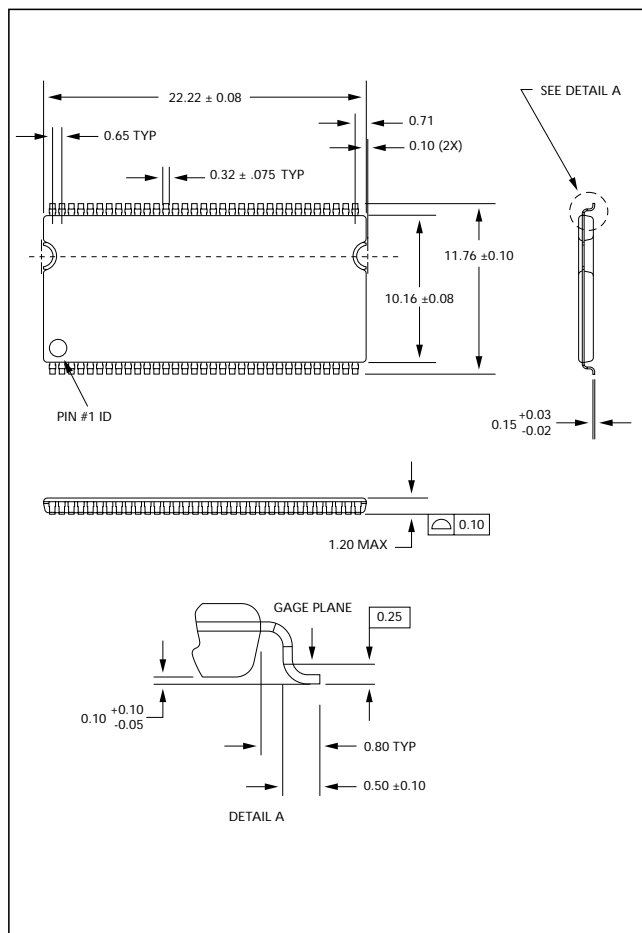

## 66-PIN TSOP PACKAGE PIN ASSIGNMENT

(TOP VIEW)

x4	x8	x16			x16	x8	x4
Vdd	Vdd	Vdd	1	•	66	Vss	Vss
NC	DQ0	DQ0	2		65	DQ15	DQ7
VddQ	VddQ	VddQ	3		64	VssQ	VssQ
NC	NC	DQ1	4		63	DQ14	NC
DQ0	DQ1	DQ2	5		62	DQ13	DQ6
VssQ	VssQ	VssQ	6		61	VddQ	VddQ
NC	NC	DQ3	7		60	DQ12	NC
NC	DQ2	DQ4	8		59	DQ11	DQ5
VddQ	VddQ	VddQ	9		58	VssQ	VssQ
NC	NC	DQ5	10		57	DQ10	NC
DQ1	DQ3	DQ6	11		56	DQ9	DQ4
VssQ	VssQ	VssQ	12		55	VddQ	VddQ
NC	NC	DQ7	13		54	DQ8	NC
NC	NC	NC	14		53	NC	NC
VddQ	VddQ	VddQ	15		52	VssQ	VssQ
NC	NC	LDQS	16		51	UDQS	DQS
NC	NC	NC	17		50	DNU	DNU
Vdd	Vdd	Vdd	18		49	VREF	VREF
DNU	DNU	DNU	19		48	Vss	Vss
NC	NC	LDM	20		47	UDM	DM
WE#	WE#	WE#	21		46	CK#	CK#
CAS#	CAS#	CAS#	22		45	CK	CK
RAS#	RAS#	RAS#	23		44	CKE	CKE
CS#	CS#	CS#	24		43	NC	NC
NC	NC	NC	25		42	A12	A12
BA0	BA0	BA0	26		41	A11	A11
BA1	BA1	BA1	27		40	A9	A9
A10/AP	A10/AP	A10/AP	28		39	A8	A8
A0	A0	A0	29		38	A7	A7
A1	A1	A1	30		37	A6	A6
A2	A2	A2	31		36	A5	A5
A3	A3	A3	32		35	A4	A4
Vdd	Vdd	Vdd	33		34	Vss	Vss

- NOTE:**
1. All dimensions in millimeters.
  2. Package width and length do not include mold protrusion; allowable mold protrusion is 0.25mm per side.



## PIN DESCRIPTIONS

BALL / PIN NUMBERS		SYMBOL	TYPE	DESCRIPTION
FBGA	TSOP			
G2, G3	45, 46	CK, CK#	Input	Clock: CK and CK# are differential clock inputs. All address and control input signals are sampled on the crossing of the positive edge of CK and negative edge of CK#. Output data (DQs and DQS) is referenced to the crossings of CK and CK#.
H3	44	CKE	Input	Clock Enable: CKE HIGH activates and CKE LOW deactivates the internal clock, input buffers and output drivers. Taking CKE LOW provides PRECHARGE POWER-DOWN and SELF REFRESH operations (all banks idle), or ACTIVE POWER-DOWN (row ACTIVE in any bank). CKE is synchronous for POWER-DOWN entry and exit, and for SELF REFRESH entry. CKE is asynchronous for SELF REFRESH exit and for disabling the outputs. CKE must be maintained HIGH throughout read and write accesses. Input buffers (excluding CK, CK# and CKE) are disabled during POWER-DOWN. Input buffers (excluding CKE) are disabled during SELF REFRESH. CKE is an SSTL_2 input but will detect an LVCMOS LOW level after V <sub>DD</sub> is applied.
H8	24	CS#	Input	Chip Select: CS# enables (registered LOW) and disables (registered HIGH) the command decoder. All commands are masked when CS# is registered HIGH. CS# provides for external bank selection on systems with multiple banks. CS# is considered part of the command code.
H7, G8, G7	23, 22, 21	RAS#, CAS#, WE#	Input	Command Inputs: RAS#, CAS#, and WE# (along with CS#) define the command being entered.
3F F7, 3F	47 20, 47	DM LDM, UDM	Input	Input Data Mask: DM is an input mask signal for write data. Input data is masked when DM is sampled HIGH along with that input data during a WRITE access. DM is sampled on both edges of DQS. Although DM pins are input-only, the DM loading is designed to match that of DQ and DQS pins. For the x16, LDM is DM for DQ0-DQ7 and UDM is DM for DQ8-DQ15. Pin 20 is a NC on x4 and x8
J8, J7	26, 27	BA0, BA1	Input	Bank Address Inputs: BA0 and BA1 define to which bank an ACTIVE, READ, WRITE, or PRECHARGE command is being applied.
K7, L8, L7 M8, M2, L3 L2, K3, K2 J3, K8, J2	29-32 32, 35, 36 36, 38, 39 40, 29, 41	A0, A1, A2 A3, A4, A5 A6, A7, A8 A9, A10, A11	Input	Address Inputs: Provide the row address for ACTIVE commands, and the column address and auto precharge bit (A10) for READ/WRITE commands, to select one location out of the memory array in the respective bank. A10 sampled during a PRECHARGE command determines whether the PRECHARGE applies to one bank (A10 LOW, bank selected by BA0, BA1) or all banks (A10 HIGH). The address inputs also provide the op-code during a MODE REGISTER SET command. BA0 and BA1 define which mode register (mode register or extended mode register) is loaded during the LOAD MODE REGISTER command.

(continued on next page)



## PIN DESCRIPTIONS (continued)

BALL / PIN NUMBERS		SYMBOL	TYPE	DESCRIPTION
FBGA	TSOP			
A8, B9, B7 C9, C7, D9 D7, E9, E1 D3, D1, C3 C1, B3, B1, A2	2, 4, 5, 7, 8, 10 11, 13, 54 56, 57, 59 60, 62, 63, 65	DQ0-2 DQ3-5 DQ6-8 DQ9-11 DQ12-14 DQ15	I/O	Data Input/Output: Data bus for <b>x16</b>
A8, B7, C7, D7, D3, C3, B3, A2	2, 5, 8, 11, 56, 59 62, 65	DQ0-2 DQ3-5 DQ6-7	I/O	Data Input/Output: Data bus for <b>x8</b>
B7, D7, D3, B3	5, 11, 56 62	DQ0-2 DQ2	I/O	Data Input/Output: Data bus for <b>x4</b>
E3 E7, E3	51 16, 51	DQS LDQS, UDQS	I/O	Data Strobe: Output with read data, input with write data. DQS is edge-aligned with read data, centered in write data. It is used to capture data. For the x16, LDQS is DQS for DQ0-DQ7 and UDQS is DQS for DQ8-DQ15. Pin 16 (H7) is NC on x4 and x8.
	14, 17, 25, 43, 53	NC	-	No Connect: These pins should be left unconnected.
	19, 50	DNU	-	Do Not Use: Must float to minimize noise on Vref
B2, D2, C8, E8, A9	3, 9, 15, 55, 61	V <sub>DDQ</sub>	Supply	DQ Power Supply: +2.5V ±0.2V. Isolated on the die for improved noise immunity.
A1, E2, B8, D8	6, 12, 52, 58, 64	V <sub>SSQ</sub>	Supply	DQ Ground. Isolated on the die for improved noise immunity.
F8, M7, A7	1, 18, 33	V <sub>DD</sub>	Supply	Power Supply: +2.5V ±0.2V.
A1, A3, F2, M3	34, 48, 66	V <sub>SS</sub>	Supply	Ground.
F1	49	V <sub>REF</sub>	Supply	SSTL_2 reference voltage.
F9	17	A13	I	Address input A13 for 1Gb devices.
H2	42	A12	I	For 256Mb and greater devices.



## GENERAL DESCRIPTION

The DDR333 SDRAM is a high-speed CMOS, dynamic random-access memory that operates at a frequency of 167 MHz ( $t_{CK}=6ns$ ) with a peak data transfer rate of 333Mb/s/p. DDR333 continues to use the JEDEC standard SSTL\_2 interface and the  $2n$ -prefetch architecture.

The standard DDR200/DDR266 data sheets also pertain to the DDR333 device and should be referenced for a complete description of DDR SDRAM function-

ality and operating modes. However, to meet the faster DDR333 operating frequencies, some of the AC timing parameters are slightly tighter. This addendum data sheet will concentrate on the key differences required to support the enhanced speeds.

In addition to the standard 66-pin TSOP package, a 60-ball FBGA package is utilized for DDR333. This JEDEC-defined package promotes better package parasitic parameters and a smaller footprint.

## CAPACITANCE (FBGA)

(Notes: 1-5, 14-17, 33; notes appear in DDR200/266 data sheets)  
( $0^{\circ}C \leq T_A \leq 70^{\circ}C$ ;  $V_{DDQ} = +2.5V \pm 0.2V$ ,  $V_{DD} = +2.5V \pm 0.2V$ )

PARAMETER	SYMBOL	MIN	MAX	UNITS	NOTES
Delta Input/Output Capacitance:					
DQs, DQS, DM (for x4 or x8 devices)	DC <sub>IO</sub>	–	0.50	pF	13, 24
DQ0-DQ7, LDQS, LDM (for lower byte of x16 devices),	DC <sub>IO</sub>	–	0.50	pF	13, 24
DQ8-DQ15, UDQS, UDM (for upper byte of x16 devices)	DC <sub>IO</sub>	–	0.50	pF	13, 29
Delta Input Capacitance: Command and Address	DC <sub>I1</sub>	–	0.50	pF	13, 29
Delta Input Capacitance: CK, CK#	DC <sub>I2</sub>	–	0.25	pF	13, 29
Input/Output Capacitance: DQs, DQS, DM (LDQS, LDM, UDM)	C <sub>IO</sub>	3.50	4.00	pF	13
Input Capacitance: Command and Address	C <sub>I1</sub>	1.50	2.50	pF	13
Input Capacitance: CK, CK#	C <sub>I2</sub>	1.50	2.50	pF	13
Input Capacitance: CKE	C <sub>I3</sub>	1.50	2.50	pF	13

## CAPACITANCE (TSOP)

(Notes: 1-5, 14-17, 33; notes appear in DDR200/266 data sheets)  
( $0^{\circ}C \leq T_A \leq 70^{\circ}C$ ;  $V_{DDQ} = +2.5V \pm 0.2V$ ,  $V_{DD} = +2.5V \pm 0.2V$ )

PARAMETER	SYMBOL	MIN	MAX	UNITS	NOTES
Delta Input/Output Capacitance:					
DQs, DQS, DM (for x4 or x8 devices)	DC <sub>IO</sub>	–	0.50	pF	13, 24
DQ0-DQ7, LDQS, LDM (for lower byte of x16 devices),	DC <sub>IO</sub>	–	0.50	pF	13, 24
DQ8-DQ15, UDQS, UDM (for upper byte of x16 devices)	DC <sub>IO</sub>	–	0.50	pF	13, 24
Delta Input Capacitance: Command and Address	DC <sub>I1</sub>	–	0.50	pF	13, 29
Delta Input Capacitance: CK, CK#	DC <sub>I2</sub>	–	0.25	pF	13, 29
Input/Output Capacitance: DQs, DQS, DM (LDQS, LDM, UDM)	C <sub>IO</sub>	4.0	5.0	pF	13
Input Capacitance: Command and Address	C <sub>I1</sub>	2.0	3.0	pF	13
Input Capacitance: CK, CK#	C <sub>I2</sub>	2.0	3.0	pF	13
Input Capacitance: CKE	C <sub>I3</sub>	2.0	3.0	pF	13



## ELECTRICAL CHARACTERISTICS AND RECOMMENDED AC OPERATING CONDITIONS

(Notes: 1-5, 14-17, 33; notes appear in DDR200/266 data sheets)

( $0^{\circ}\text{C} \leq T_A \leq 70^{\circ}\text{C}$ ;  $V_{DDQ} = +2.5\text{V} \pm 0.2\text{V}$ ,  $V_{DD} = +2.5\text{V} \pm 0.2\text{V}$ )

AC CHARACTERISTICS			-6 (FBGA)		-6T (TSOP)		-75Z			
PARAMETER		SYMBOL	MIN	MAX	MIN	MAX	MIN	MAX	UNITS	NOTES
Access window of DQs from CK/CK#		$t_{AC}$	-0.7	+0.7	-0.7	+0.7	-0.75	+0.75	ns	
CK high-level width		$t_{CH}$	0.45	0.55	0.45	0.55	0.45	0.55	$t_{CK}$	30
CK low-level width		$t_{CL}$	0.45	0.55	0.45	0.55	0.45	0.55	$t_{CK}$	30
Clock cycle time	CL = 2.5	$t_{CK} (2.5)$	6	13	6	13	7.5	13	ns	45,52
	CL = 2	$t_{CK} (2)$	7.5	13	7.5	13	7.5	13	ns	45,52
DQ and DM input hold time relative to DQS		$t_{DH}$	0.45		0.45		0.50		ns	26,31
DQ and DM input setup time relative to DQS		$t_{DS}$	0.45		0.45		0.50		ns	26,31
DQ and DM input pulse width (for each input)		$t_{DIPW}$	1.75		1.75		1.75		ns	31
Access window of DQS from CK/CK#		$t_{DQSCK}$	-0.60	+0.60	-0.60	+0.60	-0.75	+0.75	ns	
DQS input high pulse width		$t_{DQSH}$	0.35		0.35		0.35		$t_{CK}$	
DQS input low pulse width		$t_{DQSL}$	0.35		0.35		0.35		$t_{CK}$	
DQS-DQ skew, DQS to last DQ valid, per group, per access		$t_{DQSQ}$		0.35		0.45		0.50	ns	25, 26
Write command to first DQS latching transition		$t_{DQSS}$	0.75	1.25	0.75	1.25	0.75	1.25	$t_{CK}$	
DQS falling edge to CK rising - setup time		$t_{DSS}$	0.2		0.2		0.2		$t_{CK}$	
DQS falling edge from CK rising - hold time		$t_{DSH}$	0.2		0.2		0.2		$t_{CK}$	
Half clock period		$t_{HP}$	$t_{CH}, t_{CL}$		$t_{CH}, t_{CL}$		$t_{CH}, t_{CL}$		ns	34
Data-out high-impedance window from CK/CK#		$t_{HZ}$		+0.70		+0.70		+0.75	ns	18,42
Data-out low-impedance window from CK/CK#		$t_{LZ}$	-0.70		-0.70		-0.75		ns	18,43
Address and control input hold time (fast slew rate)		$t_{IH_f}$	0.75		0.75		0.90		ns	14
Address and control input setup time (fast slew rate)		$t_{IS_f}$	0.75		0.75		0.90		ns	14
Address and control input hold time (slow slew rate)		$t_{IH_s}$	0.80		0.80		1		ns	14
Address and control input setup time (slow slew rate)		$t_{IS_s}$	0.80		0.80		1		ns	14
Address and control input pulse width		$t_{IPW}$	2.2		2.2		2.2		ns	
LOAD MODE REGISTER command cycle time		$t_{MRD}$	12		12		15		ns	
DQ-DQS hold, DQS to first DQ to go non-valid, per access		$t_{QH}$	$t_{HP}$ - $t_{QHS}$		$t_{HP}$ - $t_{QHS}$		$t_{HP}$ - $t_{QHS}$		ns	25, 26
Data Hold Skew Factor		$t_{QHS}$		0.50		0.60		0.75	ns	
ACTIVE to AUTOPRECHARGE command		$t_{RAP}$	18		18		20		ns	46
ACTIVE to PRECHARGE command		$t_{RAS}$	42	70,000	42	70,000	40	120,000	ns	35
ACTIVE to ACTIVE/AUTO REFRESH command period		$t_{RC}$	60		60		65		ns	
AUTO REFRESH command period		$t_{RFC}$	72		72		75		ns	50
ACTIVE to READ or WRITE delay		$t_{RCD}$	18		18		20		ns	
PRECHARGE command period		$t_{RP}$	18		18		20		ns	
DQS read preamble		$t_{RPRE}$	0.9	1.1	0.9	1.1	0.9	1.1	$t_{CK}$	42
DQS read postamble		$t_{RPST}$	0.4	0.6	0.4	0.6	0.4	0.6	$t_{CK}$	
ACTIVE bank <i>a</i> to ACTIVE bank <i>b</i> command		$t_{RRD}$	12		12		15		ns	
DQS write preamble		$t_{WPRE}$	0.25		0.25		0.25		$t_{CK}$	
DQS write preamble setup time		$t_{WPRES}$	0		0		0		ns	20, 21
DQS write postamble		$t_{WPST}$	0.4	0.6	0.4	0.6	0.4	0.6	$t_{CK}$	19
Write recovery time		$t_{WR}$	15		15		15		ns	
Internal WRITE to READ command delay		$t_{WTR}$	1		1		1		$t_{CK}$	
Data valid output window	na	$t_{QH} - t_{DQSQ}$			$t_{QH} - t_{DQSQ}$		$t_{QH} - t_{DQSQ}$		ns	25
REFRESH to REFRESH command interval		$t_{REFC}$		140.6		140.6		140.6	$\mu\text{s}$	23
Average periodic refresh interval		$t_{REFI}$		15.6		15.6		15.6	$\mu\text{s}$	23
Terminating voltage delay to $V_{DD}$		$t_{VTD}$	0		0		0		ns	
Exit SELF REFRESH to non-READ command		$t_{XSNR}$	75		75		75		ns	
Exit SELF REFRESH to READ command		$t_{XSRD}$	200		200		200		$t_{CK}$	

**PRELIMINARY**



**128Mb: x4, x8, x16  
DDR333 SDRAM Addendum**



**8000 S. Federal Way, P.O. Box 6, Boise, ID 83707-0006, Tel: 208-368-3900**

**E-mail: [prodmktg@micron.com](mailto:prodmktg@micron.com), Internet: <http://www.micron.com>, Customer Comment Line: 800-932-4992**

Micron is a registered trademark and the Micron logo and M logo are trademarks of Micron Technology, Inc.