



FLASH MEMORY

MT28F321P20 MT28F321P18

Low Voltage, Extended Temperature
0.18µm Process Technology

FEATURES

- Flexible dual-bank architecture
 - Support for true concurrent operation with zero latency
 - Read bank *a* during program bank *b* and vice versa
 - Read bank *a* during erase bank *b* and vice versa
- Basic configuration:
 - Seventy-one erasable blocks
 - Bank *a* (4Mb for data storage)
 - Bank *b* (28Mb for program storage)
- V_{CC} , V_{CCQ} , V_{PP} voltages*
 - 1.70V (MIN), 1.90V (MAX) V_{CC} , V_{CCQ} (MT28F321P18)
 - 1.80V (MIN), 2.20V (MAX) V_{CC} , V_{CCQ} (MT28F321P20)
 - 0.9V (MIN) V_{PP} (in-system PROGRAM/ERASE)
 - 12V \pm 5% (HV) V_{PP} tolerant (factory programming compatibility)
- Random access time: 70ns and 80ns @ 1.80V V_{CC} *
- Page Mode read access*
 - Eight-word page
 - Interpage read access: 70ns/80ns @ 1.80V
 - Intrapage read access: 30ns @ 1.80V
- Low power consumption ($V_{CC} = 2.20V$)
 - Asynchronous READ < 15mA
 - Standby < 50µA
 - Automatic power save (APS) feature
- Enhanced write and erase suspend options
 - ERASE-SUSPEND-to-READ within same bank
 - PROGRAM-SUSPEND-to-READ within same bank
 - ERASE-SUSPEND-to-PROGRAM within same bank
- Dual 64-bit chip protection registers for security purposes
- Cross-compatible command support
 - Extended command set
 - Common flash interface
- PROGRAM/ERASE cycle
 - 100,000 WRITE/ERASE cycles per block

* Data based on MT28F321P20 device.

BALL ASSIGNMENT 48-Ball FBGA

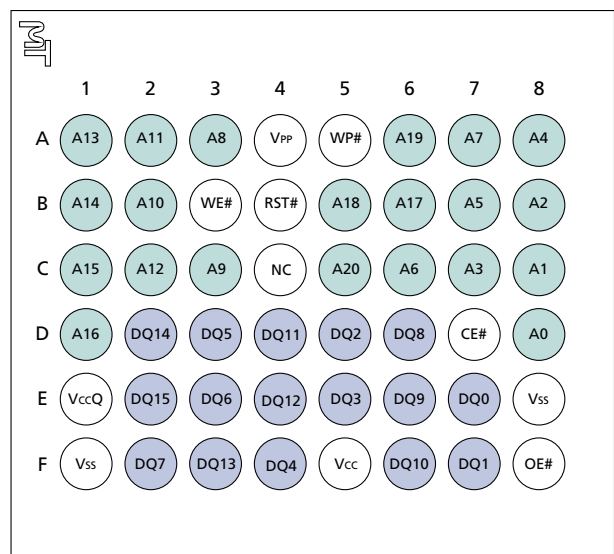

Top View
(Ball Down)

NOTE: See page 7 for Ball Description Table.
See page 33 for mechanical drawing.

OPTIONS

- Timing
 - 70ns access -70
 - 80ns access -80
 - 90ns access -90
- Boot Block Configuration
 - Top T
 - Bottom B
- Package
 - 48-ball FBGA (6 x 8 ball grid) FG
- Operating Temperature Range
 - Extended (-40°C to +85°C) ET

MARKING

Part Number Example:

MT28F321P20FG-70 TET



GENERAL DESCRIPTION

The MT28F321P20 and MT28F321P18 are high-performance, high-density, nonvolatile memory solutions that can significantly improve system performance. This new architecture features a two-memory-bank configuration that supports background operation with no latency.

A high-performance bus interface allows a fast page mode, data transfer; a conventional asynchronous bus interface is provided as well.

The devices allow soft protection for blocks, as read only, by configuring soft protection registers with dedicated command sequences. For security purposes, two 64-bit chip protection registers are provided.

The embedded WORD WRITE and BLOCK ERASE functions are fully automated by an on-chip write state machine (WSM). Two on-chip status registers, one for each of the two memory partitions, can be used to monitor the WSM status and to determine the progress of the program/erase task.

The erase/program suspend functionality allows compatibility with existing EEPROM emulation software packages.

The device is manufactured using 0.18 μ m process technology.

Please refer to Micron's Web site (www.micron.com/flash) for the latest data sheet.

ARCHITECTURE AND MEMORY ORGANIZATION

The Flash devices contain two separate banks of memory (bank *a* and bank *b*) for simultaneous READ and WRITE operations.

The Flash memory devices are available in the following bank segmentation configuration:

- Bank *a* comprises one-eighth of the memory and contains 8 x 4K-word parameter blocks; the remainder of bank *a* is split into 7 x 32K-word blocks.
- Bank *b* represents seven-eighths of the memory, is equally sectored, and contains 48 x 32K-word blocks.

Figures 2 and 3 show the bottom and top memory organizations.

DEVICE MARKING

Due to the size of the package, Micron's standard part number is not printed on the top of each device. Instead, an abbreviated device mark comprised of a five-digit alphanumeric code is used. The abbreviated device marks are cross referenced to Micron part numbers in Table 1.

Table 1
Cross Reference for Abbreviated Device Marks

PART NUMBER	PRODUCT MARKING	SAMPLE MARKING	MECHANICAL SAMPLE MARKING
MT28F321P20FG-70 BET	FW818	FX818	FY818
MT28F321P20FG-70 TET	FW819	FX819	FY819
MT28F321P20FG-80 BET	FW810	FX810	FY810
MT28F321P20FG-80 TET	FW811	FX811	FY811
MT28F321P18FG-90 BET	FW820	FX820	FY820
MT28F321P18FG-90 TET	FW821	FX821	FY821



PART NUMBERING INFORMATION

Micron's low-power devices are available with several different combinations of features (see Figure 1).

Valid combinations of features and their corresponding part numbers are listed in Table 2.

**Figure 1
Part Number Chart**

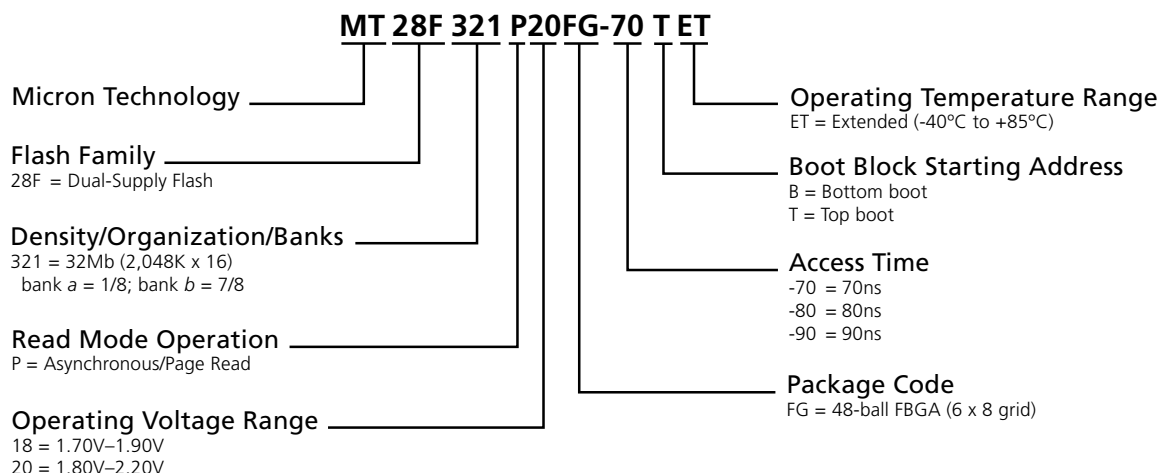

**Table 2
Valid Part Number Combinations**

PART NUMBER	ACCESS TIME (ns)	BOOT BLOCK STARTING ADDRESS	OPERATING TEMPERATURE RANGE
MT28F321P20FG-70 BET	70	Bottom	-40°C to +85°C
MT28F321P20FG-70 TET	70	Top	-40°C to +85°C
MT28F321P20FG-80 BET	80	Bottom	-40°C to +85°C
MT28F321P20FG-80 TET	80	Top	-40°C to +85°C
MT28F321P18FG-90 BET	90	Bottom	-40°C to +85°C
MT28F321P18FG-90 TET	90	Top	-40°C to +85°C



FUNCTIONAL BLOCK DIAGRAM

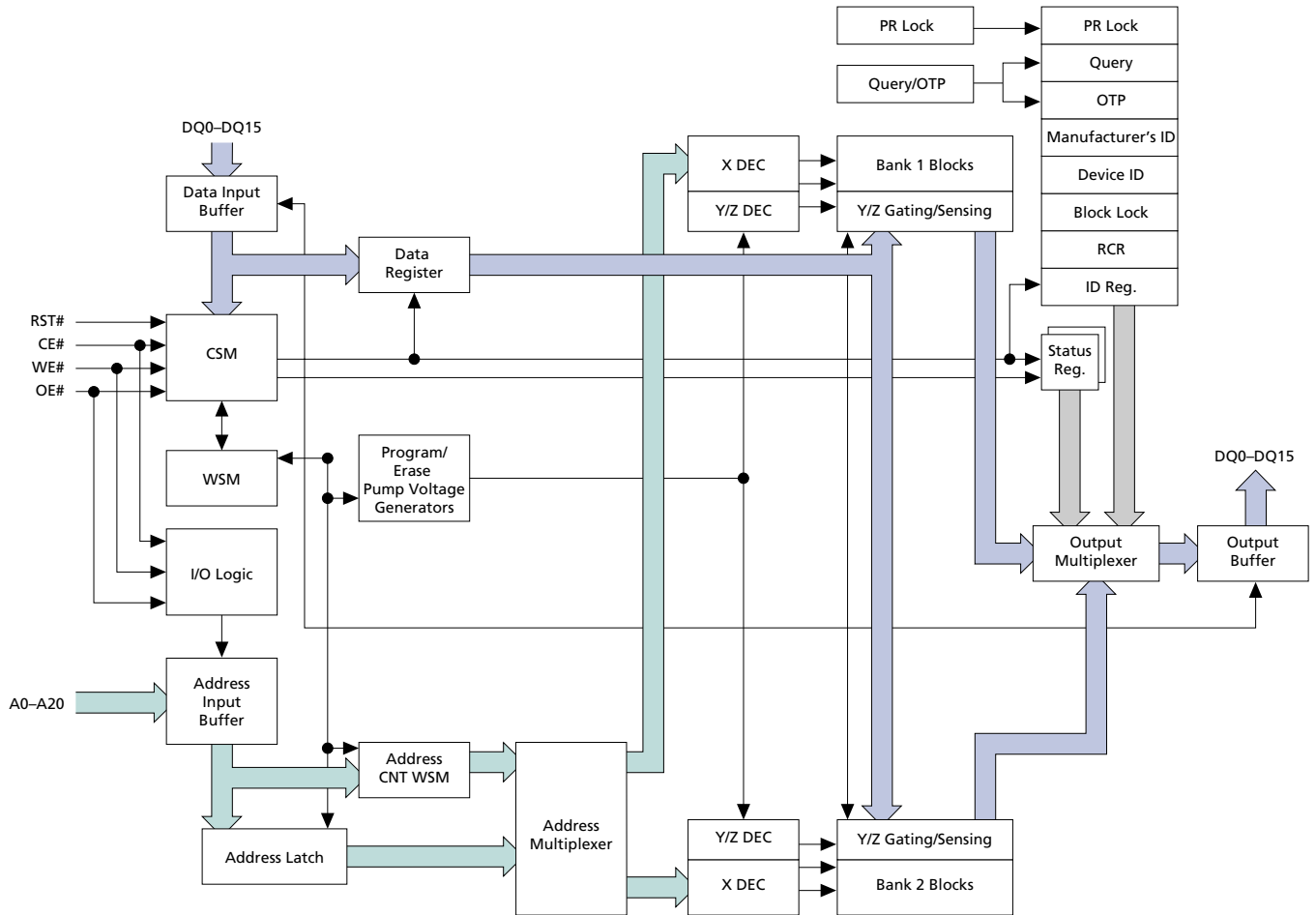



Figure 2
Bottom Boot Block Device

Bank b = 28Mb		
Block	Block Size (K-bytes/K-words)	Address Range (x16)
70	64/32	1F8000h-1FFFFFh
69	64/32	1F0000h-1F7FFFh
68	64/32	1E8000h-1EFFFFh
67	64/32	1E0000h-1E7FFFh
66	64/32	1D8000h-1DFFFFh
65	64/32	1D0000h-1D7FFFh
64	64/32	1C8000h-1CFFFFh
63	64/32	1C0000h-1C7FFFh
62	64/32	1B8000h-1BFFFFh
61	64/32	1B0000h-1B7FFFh
60	64/32	1A8000h-1AFFFFh
59	64/32	1A0000h-1A7FFFh
58	64/32	198000h-19FFFFh
57	64/32	190000h-197FFFh
56	64/32	188000h-18FFFFh
55	64/32	180000h-187FFFh
54	64/32	178000h-17FFFFh
53	64/32	170000h-177FFFh
52	64/32	168000h-16FFFFh
51	64/32	160000h-167FFFh
50	64/32	158000h-15FFFFh
49	64/32	150000h-157FFFh
48	64/32	148000h-14FFFFh
47	64/32	140000h-147FFFh
46	64/32	138000h-13FFFFh
45	64/32	130000h-137FFFh
44	64/32	128000h-12FFFFh
43	64/32	120000h-127FFFh
42	64/32	118000h-11FFFFh
41	64/32	110000h-117FFFh
40	64/32	108000h-10FFFFh
39	64/32	100000h-107FFFh
38	64/32	0F8000h-0FFFFFh
37	64/32	0F0000h-0F7FFFh
36	64/32	0E8000h-0EFFFFh
35	64/32	0E0000h-0E7FFFh
34	64/32	0D8000h-0DFFFFh
33	64/32	0D0000h-0D7FFFh
32	64/32	0C8000h-0CFFFFh
31	64/32	0C0000h-0C7FFFh
30	64/32	0B8000h-0BFFFFh
29	64/32	0B0000h-0B7FFFh
28	64/32	0A8000h-0AFFFFh
27	64/32	0A0000h-0A7FFFh
26	64/32	098000h-097FFFh
25	64/32	090000h-097FFFh
24	64/32	088000h-087FFFh
23	64/32	080000h-087FFFh
22	64/32	078000h-077FFFh
21	64/32	070000h-077FFFh
20	64/32	068000h-067FFFh
19	64/32	060000h-067FFFh
18	64/32	058000h-05FFFFh
17	64/32	050000h-057FFFh
16	64/32	048000h-04FFFFh
15	64/32	040000h-047FFFh

Bank a = 4Mb		
Block	Block Size (K-bytes/K-words)	Address Range (x16)
14	64/32	038000h-03FFFFh
13	64/32	030000h-037FFFh
12	64/32	028000h-02FFFFh
11	64/32	020000h-027FFFh
10	64/32	018000h-01FFFFh
9	64/32	010000h-017FFFh
8	64/32	008000h-00FFFFh
7	8/4	007000h-007FFFh
6	8/4	006000h-006FFFh
5	8/4	005000h-005FFFh
4	8/4	004000h-004FFFh
3	8/4	003000h-003FFFh
2	8/4	002000h-002FFFh
1	8/4	001000h-001FFFh
0	8/4	000000h-000FFFh



Figure 3
Top Boot Block Device

Bank a = 4Mb		
Block	Block Size (K-bytes/K-words)	Address Range (x16)
70	8/4	1FF000h-1FFFFFh
69	8/4	1FE000h-1FEFFFh
68	8/4	1FD000h-1FDFFFh
67	8/4	1FC000h-1FCFFFh
66	8/4	1FB000h-1FBFFFh
65	8/4	1FA000h-1FAFFFh
64	8/4	1F9000h-1F9FFFh
63	8/4	1F8000h-1F8FFFh
62	64/32	1F0000h-1F7FFFh
61	64/32	1E8000h-1E7FFFh
60	64/32	1E0000h-1E7FFFh
59	64/32	1D8000h-1D7FFFh
58	64/32	1D0000h-1D7FFFh
57	64/32	1C8000h-1C7FFFh
56	64/32	1C0000h-1C7FFFh

Bank b = 28Mb		
Block	Block Size (K-bytes/K-words)	Address Range (x16)
55	64/32	1B8000h-1BFFFFh
54	64/32	1B0000h-1B7FFFh
53	64/32	1A8000h-1AFFFFh
52	64/32	1A0000h-1A7FFFh
51	64/32	198000h-19FFFFh
50	64/32	190000h-197FFFh
49	64/32	188000h-18FFFFh
48	64/32	180000h-187FFFh
47	64/32	178000h-17FFFFh
46	64/32	170000h-177FFFh
45	64/32	168000h-16FFFFh
44	64/32	160000h-167FFFh
43	64/32	158000h-15FFFFh
42	64/32	150000h-157FFFh
41	64/32	148000h-14FFFFh
40	64/32	140000h-147FFFh
39	64/32	138000h-13FFFFh
38	64/32	130000h-137FFFh
37	64/32	128000h-12FFFFh
36	64/32	120000h-127FFFh
35	64/32	118000h-11FFFFh
34	64/32	110000h-117FFFh
33	64/32	108000h-10FFFFh
32	64/32	100000h-107FFFh
31	64/32	0F8000h-0FFFFFh
30	64/32	0F0000h-0F7FFFh
29	64/32	0E8000h-0EFFFFh
28	64/32	0E0000h-0E7FFFh
27	64/32	0D8000h-0DFFFFh
26	64/32	0D0000h-0D7FFFh
25	64/32	0C8000h-0CFFFFh
24	64/32	0C0000h-0C7FFFh
23	64/32	0B8000h-0BFFFFh
22	64/32	0B0000h-0B7FFFh
21	64/32	0A8000h-0AFFFFh
20	64/32	0A0000h-0A7FFFh
19	64/32	098000h-09FFFFh
18	64/32	090000h-097FFFh
17	64/32	088000h-08FFFFh
16	64/32	080000h-087FFFh
15	64/32	078000h-07FFFFh
14	64/32	070000h-077FFFh
13	64/32	068000h-06FFFFh
12	64/32	060000h-067FFFh
11	64/32	058000h-05FFFFh
10	64/32	050000h-057FFFh
9	64/32	048000h-04FFFFh
8	64/32	040000h-047FFFh
7	64/32	038000h-03FFFFh
6	64/32	030000h-037FFFh
5	64/32	028000h-02FFFFh
4	64/32	020000h-027FFFh
3	64/32	018000h-01FFFFh
2	64/32	010000h-017FFFh
1	64/32	008000h-00FFFFh
0	64/32	000000h-007FFFh

BALL DESCRIPTIONS

48-BALL FBGA NUMBERS	SYMBOL	TYPE	DESCRIPTION
D8, C8, B8, C7, A8, B7, C6, A7, A3, C3, B2, A2, C2, A1, B1, C1, D1, B6, B5, A6, C5	A0–A20	Input	Address Inputs: Inputs for the address during READ and WRITE operations. Addresses are internally latched during READ and WRITE cycles.
D7	CE#	Input	Chip Enable: Activates the device when LOW. When CE# is HIGH, the device is disabled and goes into standby power mode.
F8	OE#	Input	Output Enable: Enables the output buffer when LOW. When OE# is HIGH, the output buffers are disabled.
B3	WE#	Input	Write Enable: Determines if a given cycle is a WRITE cycle. If WE# is LOW, the cycle is either a WRITE to the command state machine (CSM) or to the memory array.
B4	RST#	Input	Reset: When RST# is a logic LOW, the device is in reset mode, which drives the outputs to High-Z and resets the write state machine (WSM). When RST# is at logic HIGH, the device is in standard operation. When RST# transitions from logic LOW to logic HIGH, the device resets all blocks to locked and defaults to the read array mode.
A5	WP#	Input	Write Protect: Controls the lock down function of the flexible locking feature.
A4	V _{PP}	Input	Program/Erase Enable: [0.9V–2.2V or 11.4V–12.6V] Operates as input at logic levels to control complete device protection. Provides factory programming compatibility when driven to 11.4V–12.6V.
E7, F7, D5, B5, F4, D3, E3, F2, D6, 36, F6, D4, E4, F3, D2, E2	DQ0–DQ15	Input/ Output	Data Inputs/Outputs: Input array data on the second CE# and WE# cycle during PROGRAM command. Input commands to the command user interface when CE# and WE# are active. DQ0–DQ15 output data when CE# and OE# are active.
E8, F1	V _{SS}	Supply	Do not float any ground ball.
F5	V _{CC}	Supply	Device Power Supply: [1.70V–1.90V (MT28F321P18) or 1.80V–2.20V (MT28F321P20)] Supplies power for device operation.
E1	V _{CCQ}	Supply	I/O Power Supply: [1.70V–1.90V (MT28F321P18) or 1.80V–2.20V (MT28F321P20)] Supplies power for input/output buffers.
C4	NC	–	Internally not connected.



COMMAND STATE MACHINE (CSM)

Commands are issued to the command state machine (CSM) using standard microprocessor write timings. The CSM acts as an interface between external microprocessors and the internal WSM. The available commands are listed in Table 3, their definitions are given in Table 4, and their descriptions in Table 5. Program and erase algorithms are automated by an on-chip WSM. For more specific information about the CSM transition states, see Micron technical note TN-28-33, "Command State Machine Description and Command Definition."

Once a valid PROGRAM/ERASE command is entered, the WSM executes the appropriate algorithm, which generates the necessary timing signals to control the device internally and accomplish the requested operation. A command is valid only if the exact sequence of WRITES is completed. After the WSM completes its task, the WSM status bit (SR7) (see Table 7) is set to a logic HIGH level (1), allowing the CSM to respond to the full command set again.

OPERATIONS

Device operations are selected by entering a standard JEDEC 8-bit command code with conventional microprocessor timings into an on-chip CSM through I/Os DQ0–DQ7. The number of bus cycles required to activate a command is typically one or two. The first operation is always a WRITE. Control signals CE# and WE# must be at a logic LOW level (V_{IL}), and OE# and RST# must be at logic HIGH (V_{IH}). The second operation, when needed, can be a WRITE or a READ depending upon the command. During a READ operation, control signals CE# and OE# must be at a logic LOW

level (V_{IL}), and WE# and RST# must be at logic HIGH (V_{IH}).

Table 6 shows the bus operations for all the modes: write, read, reset, standby, and output disable.

When the device is powered up, internal reset circuitry initializes the chip to a read array mode of operation. Changing the mode of operation requires that a command code be entered into the CSM. For each one of the two memory partitions, an on-chip status register is available. These two registers allow the progress of the various operations that can take place on a memory bank to be monitored. One of the two status registers is interrogated by entering a READ STATUS REGISTER command onto the CSM (cycle 1), specifying an address within the memory partition boundary, and reading the register data on I/Os DQ0–DQ7 (cycle 2). Status register bits SR0–SR7 correspond to DQ0–DQ7 (see Table 7).

COMMAND DEFINITION

Once a specific command code has been entered, the WSM executes an internal algorithm, generating the necessary timing signals to program, erase, and verify data. See Table 4 for the CSM command definitions and data for each of the bus cycles.

STATUS REGISTER

The status register allows the user to determine whether the state of a PROGRAM/ERASE operation is pending or complete. The status register is monitored by toggling OE# and CE#, and reading the resulting status code on I/Os DQ0–DQ7. The high-order I/Os (DQ8–DQ15) are set to 00h internally, so only the low-

Table 3
Command State Machine Codes For Device Mode Selection

COMMAND DQ0–DQ7	CODE ON DEVICE MODE
40h/10h	Program setup/alternate program setup
20h	Block erase setup
50h	Clear status register
60h	Protection configuration setup
70h	Read status register
90h	Read protection configuration register
98h	Read query
B0h	Program/erase suspend
C0h	Protection register program/lock
D0h	Program/erase resume – erase confirm
FFh	Read array



order I/Os (DQ0–DQ7) need to be interpreted. Address lines select the status register pertinent to the selected memory partition.

Register data is updated and latched on the falling edge of OE# or CE#, whichever occurs last. Latching the data prevents errors from occurring if the register input changes during a status register read.

The status register provides the internal state of the WSM to the external microprocessor. During periods when the WSM is active, the status register can be polled to determine the WSM status. Table 7 defines the status register bits.

After monitoring the status register during a PROGRAM/ERASE operation, the data appearing on DQ0–DQ7 remains as status register data until a new command is issued to the CSM. To return the device to other modes of operation, a new command must be issued to the CSM.

CSM OPERATIONS

The CSM decodes instructions for read array, read protection configuration register, read query, read status register, clear status register, program, erase, erase suspend, erase resume, program suspend, program resume, lock block, unlock block, and lock down block, chip protection program, and set read configuration register. The 8-bit command code is input to the device on DQ0–DQ7 (see Table 3 for CSM codes and Table 4 for command definitions). During a PROGRAM or ERASE cycle, the CSM informs the WSM that a PROGRAM or ERASE cycle has been requested.

During a PROGRAM cycle, the WSM controls the program sequences and the CSM responds to a PROGRAM SUSPEND command only.

During an ERASE cycle, the CSM responds to an ERASE SUSPEND command only. When the WSM has completed its task, the WSM status bit (SR7) is set to a logic HIGH level and the CSM responds to the full com-

Table 4
Command Definitions

COMMAND	FIRST BUS CYCLE			SECOND BUS CYCLE		
	OPERATION	ADDRESS ¹	DATA	OPERATION	ADDRESS ¹	DATA ¹
READ ARRAY	WRITE	WA	FFh			
READ PROTECTION CONFIGURATION REGISTER	WRITE	IA	90h	READ	IA	ID
READ STATUS REGISTER	WRITE	BA	70h	READ	X	SRD
CLEAR STATUS REGISTER	WRITE	BA	50h			
READ QUERY	WRITE	QA	98h	READ	QA	QD
BLOCK ERASE SETUP	WRITE	BA	20h	WRITE	BA	D0h
PROGRAM SETUP/ALTERNATE PROGRAM SETUP	WRITE	WA	40h/10h	WRITE	WA	WD
PROGRAM/ERASE SUSPEND	WRITE	BA	B0h			
PROGRAM/ERASE RESUME - ERASE CONFIRM	WRITE	BA	D0h			
LOCK BLOCK	WRITE	BA	60h	WRITE	BA	01h
UNLOCK BLOCK	WRITE	BA	60h	WRITE	BA	D0h
LOCK DOWN BLOCK	WRITE	BA	60h	WRITE	BA	2Fh
PROTECTION REGISTER PROGRAM	WRITE	PA	C0h	WRITE	PA	PD
PROTECTION REGISTER LOCK	WRITE	LPA	C0h	WRITE	LPA	FFFDh

- NOTE:** 1. BA: Address within the block
 IA: Identification code address
 ID: Identification code data
 LPA: Lock protection register address
 PA: Protection register address
 PD: Data to be written at the location PA
 QA: Query code address
 QD: Query code data
 SRD: Data read from the status register
 WA: Word address of memory location to be written, or read
 WD: Data to be written at the location WA
 X: "Don't Care"



Table 5
Command Descriptions

CODE	DEVICE MODE	BUS CYCLE	DESCRIPTION
10h	Alt. Program Setup	First	Operates the same as a PROGRAM SETUP command.
20h	Erase Setup	First	Prepares the CSM for an ERASE CONFIRM command. If the next command is not an ERASE CONFIRM command, the command will be ignored, and the bank will go to read status mode and wait for another command.
40h	Program Setup	First	A two-cycle command: The first cycle prepares for a PROGRAM operation, and the second cycle latches addresses and data and initiates the WSM to execute the program algorithm. The Flash device outputs status register data on the falling edge of OE# or CE#, whichever occurs first.
50h	Clear Status Register	First	The WSM can set the block lock status (SR3), program status (SR4), and erase status (SR5) bits in the status register to "1," but it cannot clear them to "0." Issuing this command clears those bits to "0."
60h	Protection Configuration Setup	First	Prepares the CSM for changes to the block locking status. If the next command is not BLOCK UNLOCK, BLOCK LOCK or BLOCK LOCK DOWN, the command will be ignored, and the device will go to read status mode.
70h	Read Status Register	First	Places the device into read status register mode. Reading the device will output the contents of the status register for the addressed bank. The device will automatically enter this mode for the addressed bank after a PROGRAM or ERASE operation has been initiated.
90h	Read Protection Configuration	First	Puts the device into the read protection configuration mode so that reading the device will output the manufacturer/device codes or block lock status.
98h	Read Query	First	Puts the device into the read query mode so that reading the device will output common flash interface information.
B0h	Program/Erase Suspend	First	Suspends the currently executing PROGRAM/ERASE operation. The status register will indicate when the operation has been successfully suspended by setting either the program suspend (SR2) or erase suspend (SR6), and the WSM status bit (SR7) to a "1" (ready). The WSM will continue to idle in the suspend state, regardless of the state of all input control signals except RST#, which will immediately shut down the WSM and the remainder of the chip if RST# is driven to V _{IL} .
C0h	Program Device Protection Register	First	Writes a specific code into the device protection register.
	Lock Device Protection Register	First	Locks the device protection register; data can no longer be changed.

(continued on the next page)

**Table 5
Command Descriptions (continued)**

CODE	DEVICE MODE	BUS CYCLE	DESCRIPTION
D0h	Erase Confirm	Second	If the previous command was an ERASE SETUP command, then the CSM will close the address and data latches, and it will begin erasing the block indicated on the address bus. During programming/erase, the device will respond only to the READ STATUS REGISTER, PROGRAM SUSPEND, or ERASE SUSPEND commands and will output status register data on the falling edge of OE# or CE#, whichever occurs last.
	Program/Erase Resume	First	If a PROGRAM or ERASE operation was previously suspended, this command will resume the operation.
FFh	Read Array	First	During the array mode, array data will be output on the data bus.
01h	Lock Block	Second	If the previous command was PROTECTION CONFIGURATION SETUP, the CSM will latch the address and lock the block indicated on the address bus.
2Fh	Lock Down	Second	If the previous command was PROTECTION CONFIGURATION SETUP, the CSM will latch the address and lock down the block indicated on the address bus.
D0h	Unlock Block	Second	If the previous command was PROTECTION CONFIGURATION SETUP, the CSM will latch the address and unlock the block indicated on the address bus. If the block had been previously set to lock down, this operation will have no effect.
00h	Invalid /Reserved		Unassigned command that should not be used.

mand set. The CSM stays in the current command state until the microprocessor issues another command.

The WSM successfully initiates an ERASE or PROGRAM operation only when V_{PP} is within its correct voltage range.

CLEAR STATUS REGISTER

The internal circuitry can set, but not clear, the block lock status bit (SR1), the V_{PP} status bit (SR3), the program status bit (SR4), and the erase status bit (SR5) of the status register. The CLEAR STATUS REGISTER command (50h) allows the external microprocessor to clear these status bits and synchronize to the internal operations. When the status bits are cleared, the device returns to the read array mode.

READ OPERATIONS

The following READ operations are available: READ ARRAY, READ PROTECTION CONFIGURATION REGISTER, READ QUERY and READ STATUS REGISTER.

READ ARRAY

The array is read by entering the command code FFh on DQ0–DQ7. Control signals CE# and OE# must

be at a logic LOW level (V_{IL}), and WE# and RST# must be at logic HIGH level (V_{IH}) to read data from the array. Data is available on DQ0–DQ15. Any valid address within any of the blocks selects that address and allows data to be read from that address. Upon initial power-up or device reset, the device defaults to the read array mode.

READ PROTECTION CONFIGURATION DATA

The chip identification mode outputs three types of information: the manufacturer/device identifier, the block locking status, and the protection register. Two bus cycles are required for this operation: the chip identification data is read by entering the command code 90h on DQ0–DQ7 to the bank containing address 00h and the identification code address on the address lines. Control signals CE# and OE# must be at a logic LOW level (V_{IL}), and WE# and RST# must be at a logic HIGH level (V_{IH}) to read data from the protection configuration register. Data is available on DQ0–DQ15. After data is read from the protection configuration register, the READ ARRAY command, FFh, must be issued to the bank containing address 00h prior to issuing other commands. See Table 9 for further details.



READ QUERY

The read query mode outputs common flash interface (CFI) data when the device is read (see Table 11). Two bus cycles are required for this operation. It is possible to access the query by writing the read query command code 98h on DQ0–DQ7 to the bank containing address 0h. Control signals CE# and OE# must be at a logic LOW level (V_{IL}), and WE# and RST# must be at a logic HIGH level (V_{IH}) to read data from the query. The CFI data structure contains information such as block size, density, command set, and electrical specifications. To return to read array mode, write the read array command code FFh on DQ0–DQ7.

READ STATUS REGISTER

The status register is read by entering the command code 70h on DQ0–DQ7. Two bus cycles are required for this operation: one to enter the command code and the block address and a second to read the status register. In a READ cycle, the address is latched and register data is updated on the falling edge of OE# or CE#, whichever occurs last. Register data is updated and latched on the falling edge of OE# or CE#, whichever occurs last.

PROGRAMMING OPERATIONS

There are two CSM commands for programming: PROGRAM SETUP and ALTERNATE PROGRAM SETUP (see Table 3).

After the desired command code is entered (10h or 40h command code on DQ0–DQ7), the WSM takes over and correctly sequences the device to complete the PROGRAM operation. The WRITE operation may be monitored through the status register (see the Status Register section). During this time, the CSM will only respond to a PROGRAM SUSPEND command until the PROGRAM operation has been completed, after which time all commands to the CSM become valid again. The PROGRAM operation can be suspended by issuing a PROGRAM SUSPEND command (B0h). Once the WSM reaches the suspend state, it allows the CSM to respond only to READ ARRAY, READ STATUS REGISTER, READ PROTECTION CONFIGURATION, READ QUERY, PROGRAM SETUP, or PROGRAM RESUME. During the PROGRAM SUSPEND operation, array data should be read from an address other than the one being programmed. To resume the PROGRAM operation, a PROGRAM RESUME command (D0h) must be issued to cause the CSM to clear the suspend state previously set (see Figure 4 for programming operation and Figure 5 for program suspend and program resume).

Taking RST# to V_{IL} during programming aborts the PROGRAM operation. During programming, V_{PP} must remain in the appropriate V_{PP} voltage range as shown in the recommended operating conditions table.

ERASE OPERATIONS

An ERASE operation must be used to initialize all bits in an array block to “1s.” After BLOCK ERASE confirm is issued, the CSM responds only to an ERASE SUSPEND command until the WSM completes its task.

Block erasure inside the memory array sets all bits within the address block to logic 1s. Erase is accomplished only by blocks; data at single address locations within the array cannot be erased individually. The block to be erased is selected by using any valid address within that block. Block erasure is initiated by a command sequence to the CSM: BLOCK ERASE setup (20h) followed by BLOCK ERASE CONFIRM (D0h) (see Figure 6). A two-command erase sequence protects against accidental erasure of memory contents.

When the BLOCK ERASE CONFIRM command is complete, the WSM automatically executes a sequence of events to complete the block erasure. During this sequence, the block is programmed with logic 0s, data is verified, all bits in the block are erased, and finally verification is performed to ensure that all bits are correctly erased. The ERASE operation may be monitored through the status register (see the Status Register section).

During the execution of an ERASE operation the ERASE SUSPEND command (B0h) can be entered to direct the WSM to suspend the ERASE operation. Once the WSM has reached the suspend state, it allows the CSM to respond only to the READ ARRAY, READ STATUS REGISTER, READ QUERY, READ CHIP PROTECTION CONFIGURATION, PROGRAM SETUP, PROGRAM RESUME, ERASE RESUME and LOCK SETUP (see the Block Locking section). During the ERASE SUSPEND operation, array data must be read from a block other than the one being erased. To resume the ERASE operation, an ERASE RESUME command (D0h) must be issued to cause the CSM to clear the suspend state previously set (see Figure 7). It is also possible to suspend an ERASE in any bank and initiate a WRITE to another block in the same bank. After the completion of a WRITE, an ERASE can be resumed by writing an ERASE RESUME command.



**Table 6
Bus Operations**

MODE	RST#	CE#	OE#	WE#	ADDRESS	DQ0-DQ15
Read (array, status registers, device identification register, or query)	V _{IH}	V _{IL}	V _{IL}	V _{IH}	X	D _{OUT}
Standby	V _{IH}	V _{IH}	X	X	X	High-Z
Output Disable	V _{IH}	V _{IH}	X	X	X	High-Z
Reset	V _{IL}	X	X	X	X	High-Z
Write	V _{IH}	V _{IL}	V _{IH}	V _{IL}	X	D _{IN}

**Table 7
Status Register Bit Definition**

WSMS	ESS	ES	PS	V _{PP} S	PSS	BLS	R
7	6	5	4	3	2	1	0

STATUS BIT #	STATUS REGISTER BIT	DESCRIPTION
SR7	WRITE STATE MACHINE STATUS (WSMS) 1 = Ready 0 = Busy	Check write state machine bit first to determine word program or block erase completion, before checking program or erase status bits.
SR6	ERASE SUSPEND STATUS (ESS) 1 = BLOCK ERASE Suspended 0 = BLOCK ERASE in Progress/Completed	When ERASE SUSPEND is issued, WSM halts execution and sets both WSMS and ESS bits to "1." ESS bit remains set to "1" until an ERASE RESUME command is issued.
SR5	ERASE STATUS (ES) 1 = Error in Block Erasure 0 = Successful BLOCK ERASE	When this bit is set to "1," WSM has applied the maximum number of erase pulses to the block and is still unable to verify successful block erasure.
SR4	PROGRAM STATUS (PS) 1 = Error in PROGRAM 0 = Successful PROGRAM	When this bit is set to "1," WSM has attempted but failed to program a word.
SR3	V _{PP} STATUS (V _{PP} S) 1 = V _{PP} Low Detect, Operation Abort 0 = V _{PP} = OK	The V _{PP} status bit does not provide continuous indication of the V _{PP} level. The WSM interrogates the V _{PP} level only after the program or erase command sequences have been entered and informs the system if V _{PP} < 0.9V. The V _{PP} level is also checked before the PROGRAM/ERASE operation is verified by the WSM.
SR2	PROGRAM SUSPEND STATUS (PSS) 1 = PROGRAM Suspended 0 = PROGRAM in Progress/Completed	When PROGRAM SUSPEND is issued, WSM halts execution and sets both WSMS and PSS bits to "1." PSS bit remains set to "1" until a PROGRAM RESUME command is issued.
SR1	BLOCK LOCK STATUS (BLS) 1 = PROGRAM/ERASE Attempted on a Locked Block; Operation Aborted 0 = No Operation to Locked Blocks	If a PROGRAM or ERASE operation is attempted to one of the locked blocks, this is set by the WSM. The operation specified is aborted and the device is returned to read status mode.
SR0	RESERVED FOR FUTURE ENHANCEMENT	This bit is reserved for future use.



Figure 4
Automated Word Programming
Flowchart

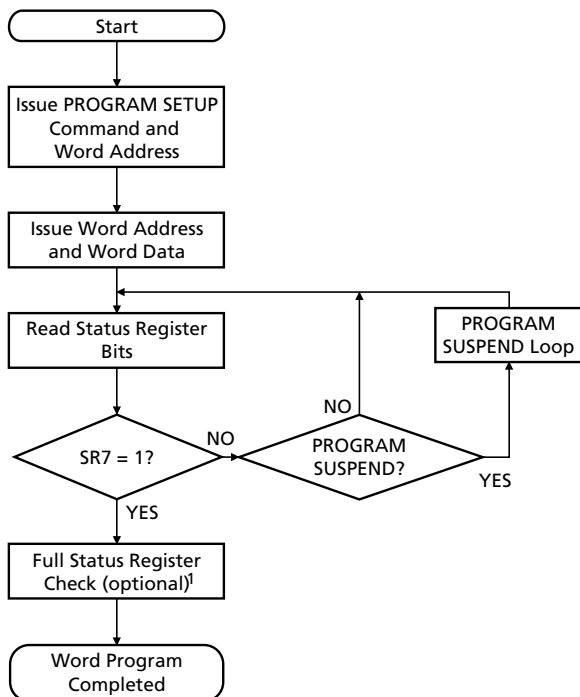

FULL STATUS REGISTER CHECK FLOW

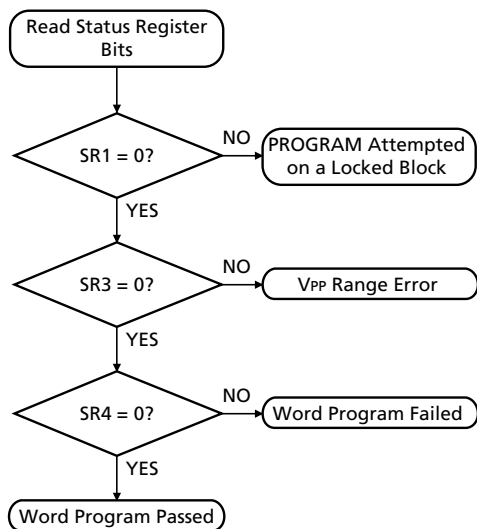

BUS OPERATION	COMMAND	COMMENTS
WRITE	WRITE PROGRAM SETUP	Data = 40h or 10h Addr = Address of word to be programmed
WRITE	WRITE DATA	Data = Word to be programmed Addr = Address of word to be programmed
READ		Status register data Toggle OE# or CE# to update status register.
Standby		Check SR7 1 = Ready, 0 = Busy
Repeat for subsequent words. Write FFh after the last word programming operation to reset the device to read array mode.		

BUS OPERATION	COMMAND	COMMENTS
Standby		Check SR1 1 = Detect locked block
Standby		Check SR3 ² 1 = Detect VPP LOW
Standby		Check SR4 ³ 1 = Word program error

- NOTE:**
1. Full status register check can be done after each word or after a sequence of words.
 2. SR3 must be cleared before attempting additional PROGRAM/ERASE operations.
 3. SR4 is cleared only by the CLEAR STATUS REGISTER command, but it does not prevent additional program operation attempts.



Figure 5
**PROGRAM SUSPEND/
PROGRAM RESUME Flowchart**

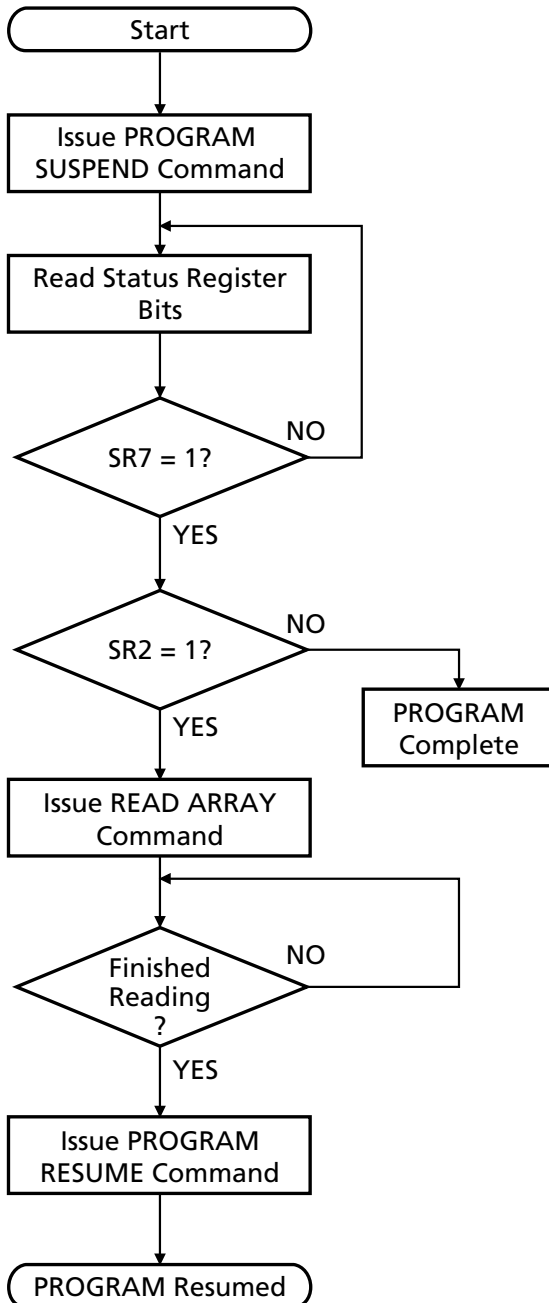

BUS OPERATION	COMMAND	COMMENTS
WRITE	PROGRAM SUSPEND	Data = B0h
READ		Status register data Toggle OE# or CE# to update status register.
Standby		Check SR7 1 = Ready
Standby		Check SR2 1 = Suspended
WRITE	READ ARRAY	Data = FFh
READ		Read data from block other than that being programmed.
WRITE	PROGRAM RESUME	Data = D0h

- NOTE:**
1. Full status register check can be done after each word or after a sequence of words.
 2. SR3 must be cleared before attempting additional PROGRAM/ERASE operations.
 3. SR5 is cleared only by the CLEAR STATUS REGISTER command in cases where multiple blocks are erased before full status is checked.



Figure 6
BLOCK ERASE Flowchart

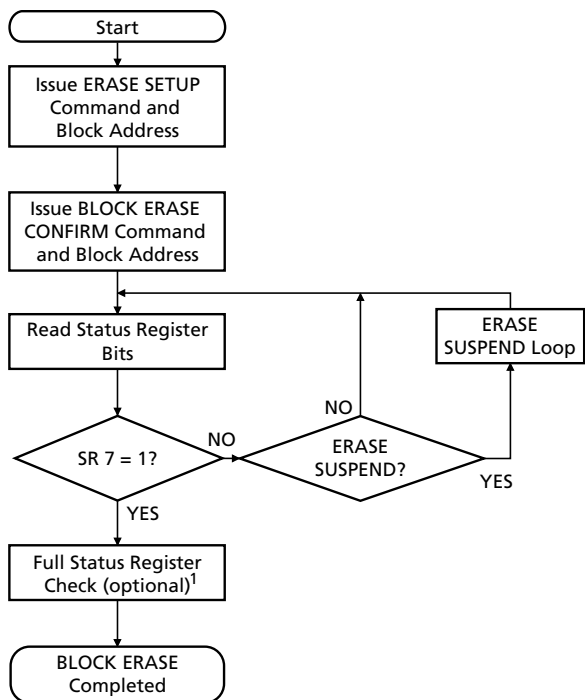

FULL STATUS REGISTER CHECK FLOW

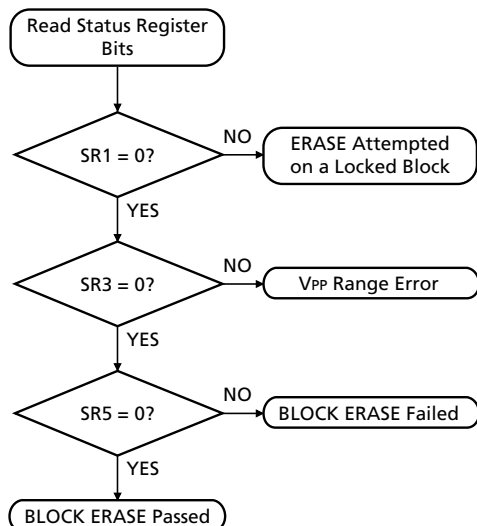

BUS OPERATION	COMMAND	COMMENTS
WRITE	WRITE ERASE SETUP	Data = 20h Block Addr = Address within block to be erased
WRITE	ERASE	Data = D0h Block Addr = Address within block to be erased
READ		Status register data Toggle OE# or CE# to update status register.
Standby		Check SR7 1 = Ready, 0 = Busy
Repeat for subsequent blocks. Write FFh after the last BLOCK ERASE operation to reset the device to read array mode.		

BUS OPERATION	COMMAND	COMMENTS
Standby		Check SR1 1 = Detect locked block
Standby		Check SR3 ² 1 = Detect V _{PP} block
Standby		Check SR5 ³ 1 = BLOCK ERASE error

- NOTE:**
1. Full status register check can be done after each block or after a sequence of blocks.
 2. SR3 must be cleared before attempting additional PROGRAM/ERASE operations.
 3. SR5 is cleared only by the CLEAR STATUS REGISTER command in cases where multiple blocks are erased before full status is checked.



Figure 7
ERASE SUSPEND/ERASE RESUME
Flowchart

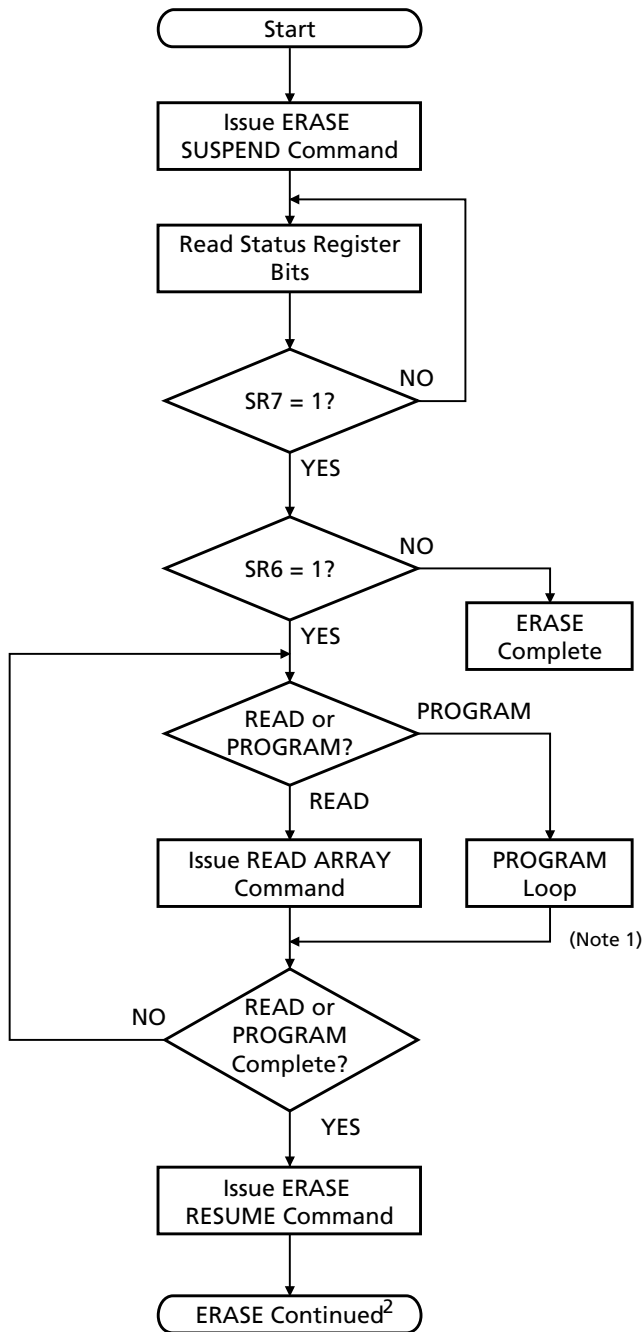

BUS OPERATION	COMMAND	COMMENTS
WRITE	ERASE SUSPEND	Data = B0h
READ		Status register data Toggle OE# or CE# to update status register.
Standby		Check SR7 1 = Ready
Standby		Check SR6 1 = Suspended
WRITE	READ ARRAY	Data = FFh
READ		Read data from block other than that being erased.
WRITE	ERASE RESUME	Data = D0h

NOTE: 1. See BLOCK ERASE Flowchart for complete erasure procedure.
2. See Word Programming Flowchart for complete programming procedure.



READ-WHILE-WRITE/ERASE CONCURRENCY

It is possible for the device to read from one bank while erasing/writing to another bank. Once a bank enters the WRITE/ERASE operation, the other bank automatically enters read array mode. For example, during a READ CONCURRENCY operation, if a PROGRAM/ERASE command is issued in bank *a*, then bank *a* changes to the read status mode and bank *b* defaults to the read array mode. The device will read from bank *b* if the latched address resides in bank *b* (see Figure 8). Similarly, if a PROGRAM/ERASE command is issued in bank *b*, then bank *b* changes to read status mode and bank *a* defaults to read array mode. When returning to bank *a*, the device will read PROGRAM/ERASE status if the latched address resides in bank *a*. A correct bank address must be specified to read status register after returning from concurrent read in the other bank.

When reading the CFI or the chip protection register, concurrent operation is not allowed on the top boot device. Concurrent READ of the CFI or the chip protection register is only allowed when a PROGRAM or ERASE operation is performed on bank *b* on the bottom boot device. For a bottom boot device, reading of the CFI table or the chip protection register is only allowed if bank *b* is in read array mode. For a top boot device, reading of the CFI table or the chip protection register is only allowed if bank *a* is in read array mode.

Figure 8
READ-While-WRITE Concurrency

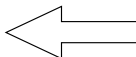
Bank <i>a</i>	Bank <i>b</i>
1 - Erasing/writing to bank <i>a</i> 2 - Erasing in bank <i>a</i> can be suspended, and a WRITE to another block in bank <i>a</i> can be initiated. 3 - After the WRITE in that block is complete, an ERASE can be resumed by writing an ERASE RESUME command.	 1 - Reading from bank <i>b</i>
1 - Reading bank <i>a</i> 	1 - Erasing/writing to bank <i>b</i> 2 - Erasing in bank <i>b</i> can be suspended, and a WRITE to another block in bank <i>b</i> can be initiated. 3 - After the WRITE in that block is complete, an ERASE can be resumed by writing an ERASE RESUME command.



BLOCK LOCKING

The Flash memory devices provide a flexible locking scheme which allows each block to be individually locked or unlocked with no latency.

The devices offer two-level protection for the blocks. The first level allows software-only control of block locking (for data which needs to be changed frequently), while the second level requires hardware interaction before locking can be changed (code which does not require frequent updates).

Control signals WP#, DQ0, and DQ1 define the state of a block; for example, state [001] means WP# = 0, DQ0 = 1 and DQ1 = 0.

Table 8 defines all of the possible locking states.

NOTE: All blocks are software-locked upon power-up sequence completion.

LOCKED STATE

After a power-up sequence completion, or after a reset sequence, all blocks are locked (states [001] or [101]). This means full protection from alteration. Any PROGRAM or ERASE operations attempted on a locked block will return an error on bit SR1 of the status register. The status of a locked block can be changed to unlocked or lock down using the appropriate software commands. Writing the lock command sequence, 60h followed by 01h, can lock an unlocked block.

UNLOCKED STATE

Unlocked blocks (states [000], [100], [110]) can be programmed or erased. All unlocked blocks return to the locked state when the device is reset or powered down. An unlocked block can be locked or locked down using the appropriate software command sequence, 60h followed by D0h (see Table 4).

LOCKED DOWN STATE

Blocks that are locked down (state [011]) are protected from PROGRAM and ERASE operations, but their protection status cannot be changed using software commands alone. A locked or unlocked block can be locked down by writing the lock down command sequence, 60h followed by 2Fh. Locked down blocks revert to the locked state when the device is reset or powered down.

The LOCK DOWN function is dependent on the WP# input. When WP# = 0, blocks in lock down [011] are protected from program, erase, and lock status changes. When WP# = 1, the lock down function is disabled ([111]), and locked down blocks can be individually unlocked by a software command to the [110] state, where they can be erased and programmed. These blocks can then be relocked [111] and unlocked [110] as desired while WP# remains HIGH. When WP# goes LOW, blocks that were previously locked down return to the locked down state [011] regardless of any changes made while WP# was HIGH. Device reset or power-down resets all locks, including those in lock down, to locked state (see Table 9).

READING A BLOCK'S LOCK STATUS

The lock status of every block can be read in the read device identification mode. To enter this mode, write 90h to the the bank containing address 00h. Subsequent READs at block address +00002 will output the lock status of that block. The lowest two outputs, DQ0 and DQ1, represent the lock status. DQ0 indicates the block lock/unlock status and is set by the LOCK command and cleared by the UNLOCK command. It is also automatically set when entering lock down. DQ1 indicates lock down status and is set by the LOCK DOWN

**Table 8
Block Locking State Transition**

WP#	DQ1	DQ0	NAME	ERASE/PROGRAM ALLOWED	LOCK	UNLOCK	LOCK DOWN
0	0	0	Unlocked	Yes	To [001]	No Change	To [011]
0	0	1	Locked (Default)	No	No Change	To [000]	To [011]
0	1	1	Lock Down	No	No Change	No Change	No Change
1	0	0	Unlocked	Yes	To [101]	No Change	To [111]
1	0	1	Locked	No	No Change	To [100]	To [111]
1	1	0	Lock Down Disabled	Yes	To [111]	No Change	To [111]
1	1	1	Lock Down Disabled	No	No Change	To [110]	No Change

command. It can only be cleared by reset or power-down, not by software. Table 8 shows the locking state transition scheme. The READ ARRAY command, FFh, must be issued to the bank containing address 00h prior to issuing other commands.

LOCKING OPERATIONS DURING ERASE SUSPEND

Changes to block lock status can be performed during an ERASE SUSPEND by using the standard locking command sequences to unlock, lock, or lock down. This is useful in the case when another block needs to be updated while an ERASE operation is in progress.

To change block locking during an ERASE operation, first write the ERASE SUSPEND command (B0h), then check the status register until it indicates that the ERASE operation has been suspended. Next, write the desired lock command sequence to block lock, and the lock status will be changed. After completing any desired LOCK, READ, or PROGRAM operations, resume the ERASE operation with the ERASE RESUME command (D0h).

If a block is locked or locked down during an ERASE SUSPEND on the same block, the locking status bits will be changed immediately. When the ERASE is resumed, the ERASE operation will complete.

A locking operation cannot be performed during a PROGRAM SUSPEND.

CHIP PROTECTION REGISTER

A 128-bit chip protection register can be used to fulfill the security considerations in the system (preventing the device substitution).

The 128-bit security area is divided into two 64-bit segments. The first 64 bits are programmed at the manufacturing site with a unique 64-bit unchangeable number. The other segment is left blank for customers to program as desired. (See Figure 9).

Figure 9
Protection Register Memory Map

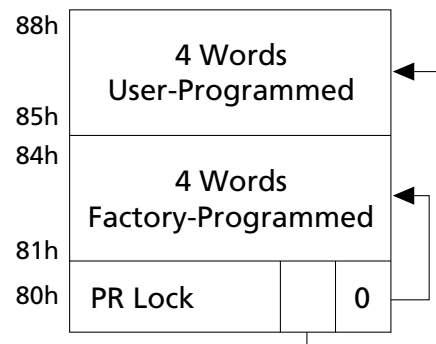

Table 9
Chip Configuration Addressing¹

ITEM	ADDRESS ²	DATA
Manufacturer Code (x16)	00000h	002Ch
Device Code	00001h	44B2h 44B3h
Block Lock Configuration	XX002h	Lock DQ0 = 0 DQ0 = 1 DQ1 = 1
Chip Protection Register Lock	80h	PR Lock
Chip Protection Register 1	81h-84h	Factory Data
Chip Protection Register 2	85h-88h	User Data

- NOTE:**
1. Other locations within the configuration address space are reserved by Micron for future use.
 2. "XX" specifies the block address of lock configuration.



READING THE CHIP PROTECTION REGISTER

The chip protection register is read in the device identification mode. To enter this mode, load the 90h command to the bank containing address 00h. Once in this mode, READ cycles from addresses shown in Table 9 retrieve the specified information. To return to the read array mode, write the READ ARRAY command (FFh). The READ ARRAY command, FFh, must be issued to the bank containing address 00h prior to issuing other commands.

PROGRAMMING THE CHIP PROTECTION REGISTER

The first 64 bits (PR1) of the protection register (addresses 81h–84h) are programmed with a unique identifier at the factory. DQ0 of the PR lock register (address 80h) is programmed to a “0” state, locking the first 64 bits and preventing any further programming. The second 64 bits (PR2) is a user area (addresses 85h–88h), where the user can program any information into this area as long as DQ1 of the PR lock register remains unprogrammed. After DQ1 of the PR lock register is programmed, no further programming is allowed on PR2. The programming sequence is similar to array programming except that the PROTECTION REGISTER PROGRAMMING SETUP command (C0h) is issued instead of an ARRAY PROGRAMMING SETUP command (40h), followed by the data to be programmed at addresses 85h–88h.

To program the PR lock bit for PR2 (to prevent further programming), use the above sequence on address 80h, with data of FFFDh (DQ1 = 0).

ASYNCHRONOUS READ CYCLE

When accessing addresses in a random order or when switching between pages, the access time is given by t_{AA} .

When CE# and OE# are LOW, the data is placed on the data bus and the processor can read the data.

PAGE READ MODE

The initial portion of the page mode cycle is the same as the asynchronous access cycle. Holding CE# LOW and toggling addresses A0–A2 allows random access of other words in the page. The page word size is eight words.

V_{PP} / V_{CC} PROGRAM AND ERASE VOLTAGES

The MT28F321P20 Flash memory provides in-system programming and erase with V_{PP} in the 0.9V–2.2V range. The 12V V_{PP} mode programming is offered for compatibility with existing programming equipment and does not enhance program/erase performance.

The device can withstand 100,000 WRITE/ERASE operations when V_{PP} = V_{PP1} or 100 WRITE/ERASE operations and 10 cumulative hours when V_{PP} = V_{PP2}.

In addition to the flexible block locking, the V_{PP} programming voltage can be held low for absolute hardware write protection of all blocks in the Flash device. When V_{PP} is below V_{PLK}, any PROGRAM or ERASE operation will result in an error, prompting the corresponding status register bit (SR3) to be set.

During WRITE and ERASE operations, the WSM monitors the V_{PP} voltage level. WRITE/ERASE operations are allowed only when V_{PP} is within the ranges specified in Table 10.

When V_{CC} is below V_{LKO}, any WRITE/ERASE operation will be disabled.

Table 10
V_{PP} Range (V)

	MIN	MAX
In-System	0.9	2.2
In-Factory	11.4	12.6



STANDBY MODE

Icc supply current is reduced by applying a logic HIGH level on CE# and RST# to enter the standby mode. In the standby mode, the outputs are placed in High-Z. Applying a CMOS logic HIGH level on CE# and RST# reduces the current to Icc3 (MAX). If the device is deselected during an ERASE operation or during programming, the device continues to draw current until the operation is complete.

AUTOMATIC POWER SAVE MODE (APS)

Substantial power savings are realized during periods when the array is not being read and the device is in the active mode. During this time the device switches to the automatic power save mode. When the device switches to this mode, Icc is reduced to a level comparable to Icc3. Further power savings can be realized by applying a logic HIGH level on CE# to place the device in standby mode. The low level of power is maintained until another operation is initiated. In this mode, the I/Os retain the data from the last memory address read until a new address is read. This mode is entered automatically if no address or control signals toggle.

DEVICE RESET

To correctly reset the Flash memory devices, the RST# signal must be asserted (RST# = VIL) for a minimum of ^tRP. After reset, the devices can be accessed for a READ operation with a delayed access time of ^tRWH from the rising edge of RST#. The circuitry used for generating the RST# signal needs to be common with the rest of the system reset to ensure that correct system initialization occurs. Please refer to the timing diagram for further details.

POWER-UP SEQUENCE

The following power-up sequence is recommended to properly initialize internal chip operations:

- At power-up, RST# should be kept at VIL for 2μs after Vcc reaches Vcc (MIN).
- VccQ should not come up before Vcc.
- Vpp should be kept at VIL to maximize data integrity.

When the power-up sequence is completed, RST# should be brought to VIH. To ensure a proper power-up, the rise time of RST# (10%–90%) should be <10μs.



ABSOLUTE MAXIMUM RATINGS*

Voltage to Any Ball Except Vcc and Vpp
 with Respect to Vss -0.5V to +2.45V
 Vpp Voltage (for BLOCK ERASE and PROGRAM
 with Respect to Vss) -0.5V to +13.5V**
 Vcc and VccQ Supply Voltage
 with Respect to Vss -0.3V to +2.45V
 Output Short Circuit Current 100mA
 Operating Temperature Range -40°C to +85°C
 Storage Temperature Range -55°C to +125°C
 Soldering Cycle 260°C for 10s

*Stresses greater than those listed under “Absolute Maximum Ratings” may cause permanent damage to the device. This is a stress rating only and functional operation of the device at these or any other conditions above those indicated in the operational sections of this specification is not implied. Exposure to absolute maximum rating conditions for extended periods may affect reliability.

**Maximum DC voltage on Vpp may overshoot to +13.5V for periods <20ns.

OPERATING CONDITIONS

PARAMETER	SYMBOL	MIN	MAX	UNITS	NOTE
Operating temperature	t _A	-40	+85	°C	
Vcc supply voltage (MT28F321P18)	Vcc	1.70	1.90	V	
Vcc supply voltage (MT28F321P20)	Vcc	1.80	2.20	V	
I/O supply voltage (MT28F321P18)	VccQ	1.70	1.90	V	
I/O supply voltage (MT28F321P20)	VccQ	1.80	2.20	V	
Vpp voltage	Vpp1	0.9	2.2	V	
Vpp in-factory programming voltage	Vpp2	11.4	12.6	V	
Block erase cycling	Vpp = Vpp1	Vpp1	–	100,000	Cycles
	Vpp = Vpp2	Vpp2	–	100	Cycles

NOTE: 1. Vpp = Vpp2 is a maximum of 10 cumulative hours.

**Figure 10
AC Input/Output Reference Waveform**

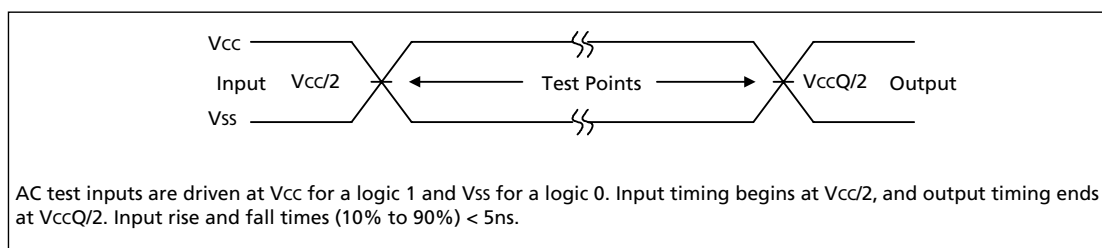

**Figure 11
Output Load Circuit**

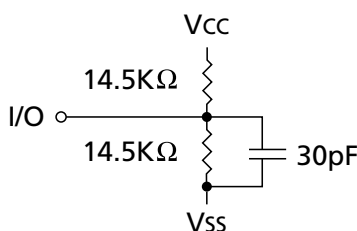

DC CHARACTERISTICS¹

PARAMETER	SYMBOL	V _{CC} /V _{CCQ} = 1.70V–1.90V or 1.80V–2.20V		UNITS	NOTES
		MIN	MAX		
Input Low Voltage	V _{IL}	0	0.4	V	2
Input High Voltage	V _{IH}	V _{CCQ} - 0.4V	V _{CCQ}	V	2
Output Low Voltage I _{OL} = 100μA	V _{OL}	–	0.10	V	
Output High Voltage I _{OH} = -100μA	V _{OH}	V _{CCQ} - 0.1V	–	V	
V _{PP} Lockout Voltage	V _{PP} LOCK	–	0.4	V	
V _{PP} During PROGRAM/ERASE Operations	V _{PP} 1	0.9	2.2	V	
	V _{PP} 2	11.4	12.6	V	
V _{CC} Program/Erase Lock Voltage	V _{LKO}	1	–	V	
Input Leakage Current	I _L	–	1	μA	
Output Leakage Current	I _{OZ}	–	1	μA	
V _{CC} Random Read Current, 70ns cycle	I _{CC} 1	–	15	mA	3, 4
V _{CC} Page Mode Read Current, 70ns/30ns cycle	I _{CC} 2	–	5	mA	3, 4
V _{CC} Standby Current	I _{CC} 3	–	50	μA	
V _{CC} Program Current	I _{CC} 4	–	55	mA	
V _{CC} Erase Current	I _{CC} 5	–	65	mA	
V _{CC} Erase Suspend Current	I _{CC} 6	–	50	μA	5
V _{CC} Program Suspend Current	I _{CC} 7	–	50	μA	5
Read-While-Write Current	I _{CC} 8	–	80	mA	
V _{PP} Current (Read, Standby, Erase Suspend, Program Suspend) V _{PP} = V _{PP} 1 V _{PP} = V _{PP} 2	I _{PP} 1	–	1	μA	
		–	200	μA	

- NOTE:**
1. All currents are in RMS unless otherwise noted.
 2. V_{IL} may decrease to -0.4V and V_{IH} may increase to V_{CCQ} + 0.3V for durations not to exceed 20ns.
 3. Test conditions: V_{CC} = V_{CC} (MAX), CE# = V_{IL}, OE# = V_{IH}. All other inputs = V_{IH} or V_{IL}.
 4. APS mode reduces I_{CC} to approximately I_{CC}3 levels.
 5. I_{CC}6 and I_{CC}7 values are valid when the device is deselected. Any READ operation performed while in suspend mode will have an additional current draw of suspend current (I_{CC}6 or I_{CC}7).



CAPACITANCE

($T_A = +25^\circ\text{C}$; $f = 1\text{ MHz}$)

PARAMETER/CONDITION	SYMBOL	TYP	MAX	UNITS
Input Capacitance	C	7	12	pF
Output Capacitance	C _{OUT}	9	12	pF

READ CYCLE TIMING REQUIREMENTS¹

MT28F321P20 ($V_{CC} = 1.80\text{V} - 2.20\text{V}$)

PARAMETER	SYMBOL	-70		-80		UNITS
		MIN	MAX	MIN	MAX	
READ cycle time	t _{RC}		70		80	ns
Address to output delay	t _{AA}		70		80	ns
CE# LOW to output delay	t _{ACE}		70		80	ns
Page address access	t _{APA}		30		30	ns
OE# LOW to output delay	t _{AOE}		25		30	ns
RST# HIGH to output delay	t _{RWH}		200		200	ns
CE# or OE# HIGH to output High-Z	t _{OD}		15		25	ns
Output hold from address, CE# or OE# change	t _{OH}	0		0		ns

READ CYCLE TIMING REQUIREMENTS¹

MT28F321P18 ($V_{CC} = 1.70\text{V} - 1.90\text{V}$)

PARAMETER	SYMBOL	-90		UNITS
		MIN	MAX	
READ cycle time	t _{RC}		90	ns
Address to output delay	t _{AA}		90	ns
CE# LOW to output delay	t _{ACE}		90	ns
Page address access	t _{APA}		35	ns
OE# LOW to output delay	t _{AOE}		30	ns
RST# HIGH to output delay	t _{RWH}		250	ns
CE# or OE# HIGH to output High-Z	t _{OD}		25	ns
Output hold from address, CE# or OE# change	t _{OH}	0		ns

NOTE: 1. See Figures 11 and 12 for timing requirements and load configuration.

WRITE CYCLE TIMING REQUIREMENTS

PARAMETER	SYMBOL	-70/-80/-90		UNITS
		MIN	MAX	
HIGH recovery to WE# going LOW	t_{RS}	150		ns
CE# setup to WE# going LOW	t_{CS}	0		ns
Write pulse width	t_{WP}	50		ns
Data setup to WE# going HIGH	t_{DS}	50		ns
Address setup to WE# going HIGH	t_{AS}	50		ns
CE# hold from WE# HIGH	t_{CH}	0		ns
Data hold from WE# HIGH	t_{DH}	0		ns
Address hold from WE# HIGH	t_{AH}	9		ns
Write pulse width HIGH	t_{WPH}	30		ns
RST# pulse width	t_{RP}	100		ns
WP# setup to WE# going HIGH	t_{RHS}	0		ns
V _{PP} setup to WE# going HIGH	t_{VPS}	200		ns
Write recovery before READ	t_{WOS}	50		ns
WP# hold from valid SRD	t_{RHH}	0		ns
V _{PP} hold from valid SRD	t_{VPPH}	0		ns
WE# HIGH to data valid	t_{WB}		$t_{AA} + 50$	ns

ERASE AND PROGRAM TIMING REQUIREMENTS

PARAMETER	-70/-80/-90		UNITS
	TYP	MAX	
4KW block program time	40	800	ms
32KW block program time	320	6400	ms
Word program time	8	10,000	μs
4KW block erase time	0.3	6	s
32KW block erase time	0.5	6	s
Program suspend latency	5	10	μs
Erase suspend latency	5	20	μs



SINGLE ASYNCHRONOUS READ OPERATION

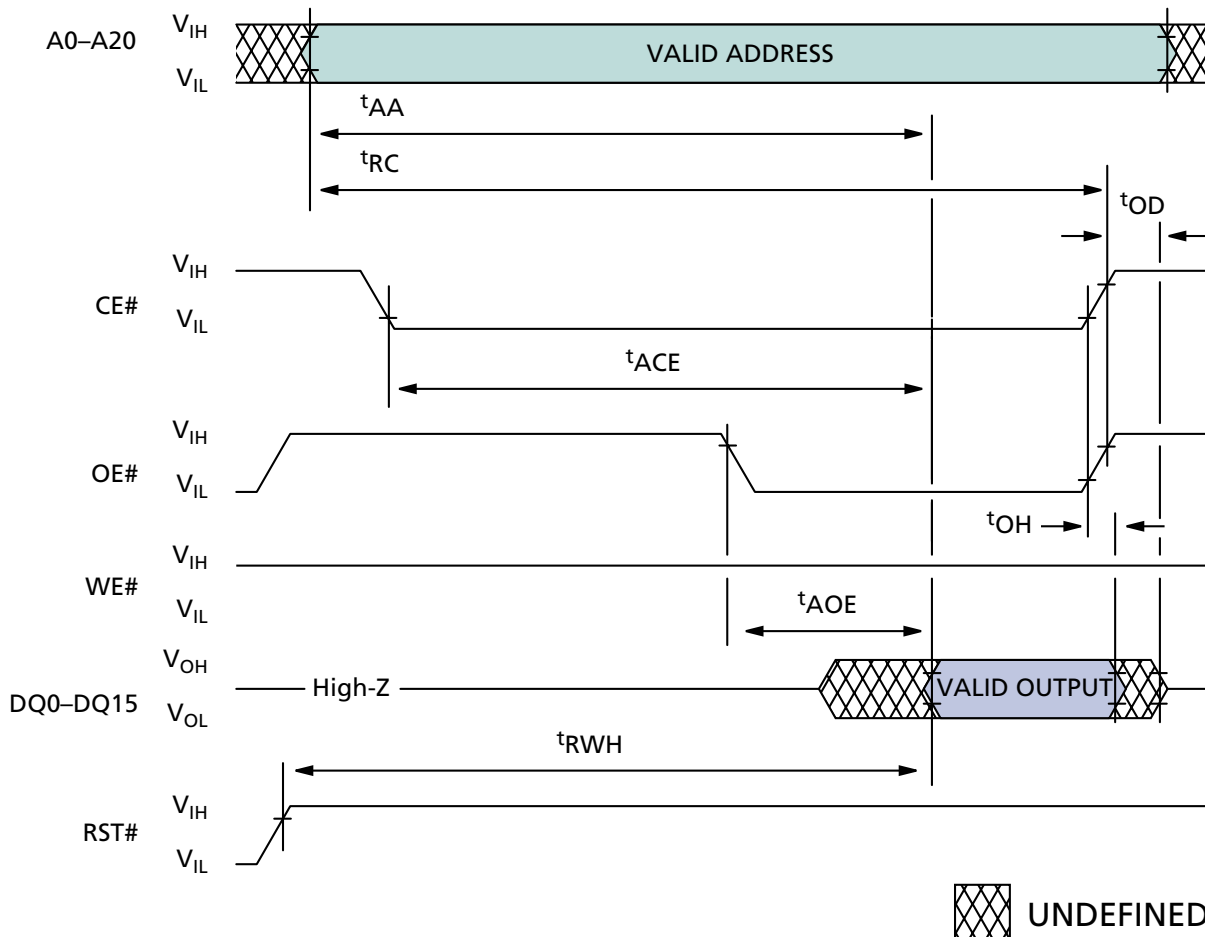

READ TIMING PARAMETERS

MT28F321P20 (V_{CC} = 1.80V–2.20V)

SYMBOL	-70		-80		UNITS
	MIN	MAX	MIN	MAX	
t _{AA}		70		80	ns
t _{ACE}		70		80	ns
t _{AOE}		25		30	ns
t _{RC}		70		80	ns
t _{RWH}		200		200	ns
t _{OD}		15		25	ns
t _{OH}	0		0		ns

READ TIMING PARAMETERS

MT28F321P18 (V_{CC} = 1.70V–1.90V)

SYMBOL	-90		UNITS
	MIN	MAX	
t _{AA}		90	ns
t _{ACE}		90	ns
t _{AOE}		30	ns
t _{RC}		90	ns
t _{RWH}		250	ns
t _{OD}		25	ns
t _{OH}	0		ns

ASYNCHRONOUS PAGE MODE READ OPERATION

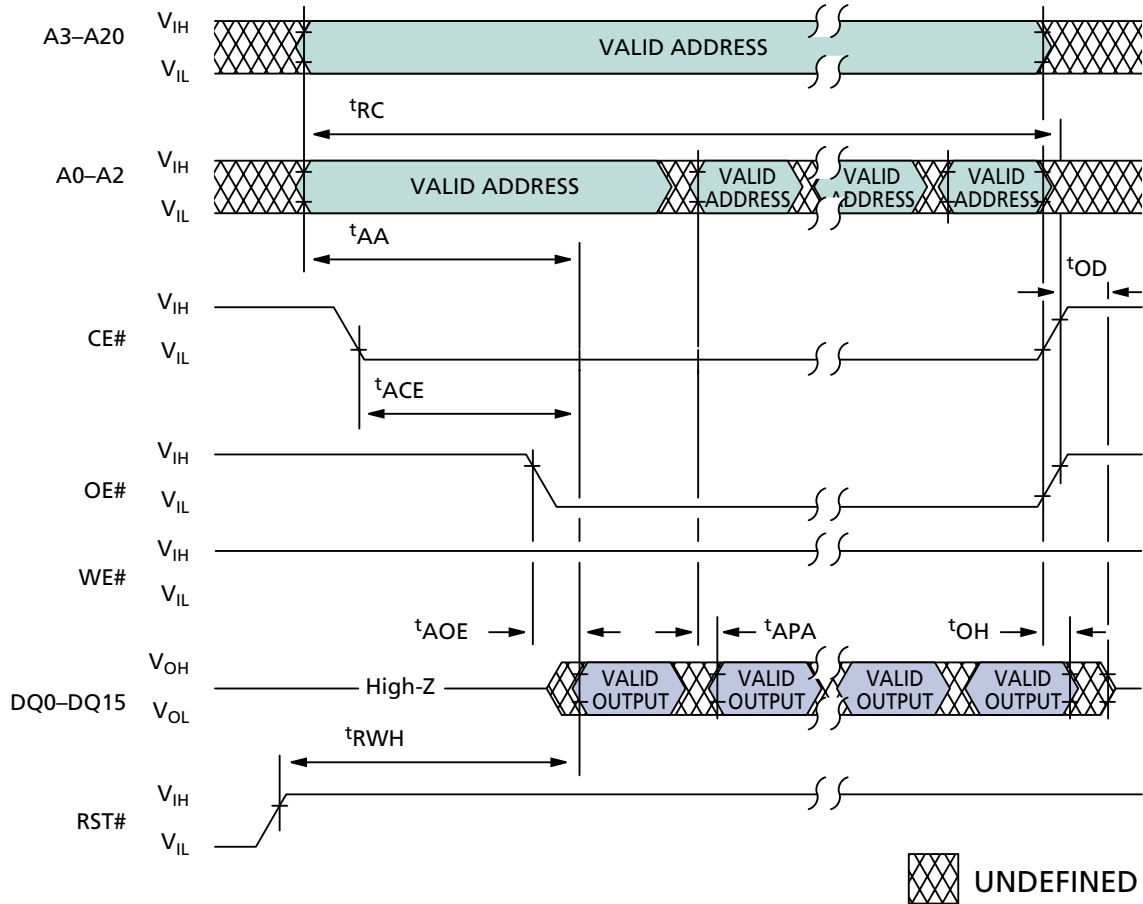

READ TIMING PARAMETERS
MT28F321P20 (V_{CC} = 1.80V–2.20V)

SYMBOL	-70		-80		UNITS
	MIN	MAX	MIN	MAX	
t _{AA}		70		80	ns
t _{ACE}		70		80	ns
t _{APA}		30		30	ns
t _{AOE}		25		30	ns
t _{RC}		70		80	ns
t _{RWH}		200		200	ns
t _{OD}		15		25	ns
t _{OH}	0		0		ns

READ TIMING PARAMETERS
MT28F321P18 (V_{CC} = 1.70V–1.90V)

SYMBOL	-90		UNITS
	MIN	MAX	
t _{AA}		90	ns
t _{ACE}		90	ns
t _{APA}		35	ns
t _{AOE}		30	ns
t _{RC}		90	ns
t _{RWH}		250	ns
t _{OD}		25	ns
t _{OH}	0		ns



TWO-CYCLE PROGRAMMING/ERASE OPERATION

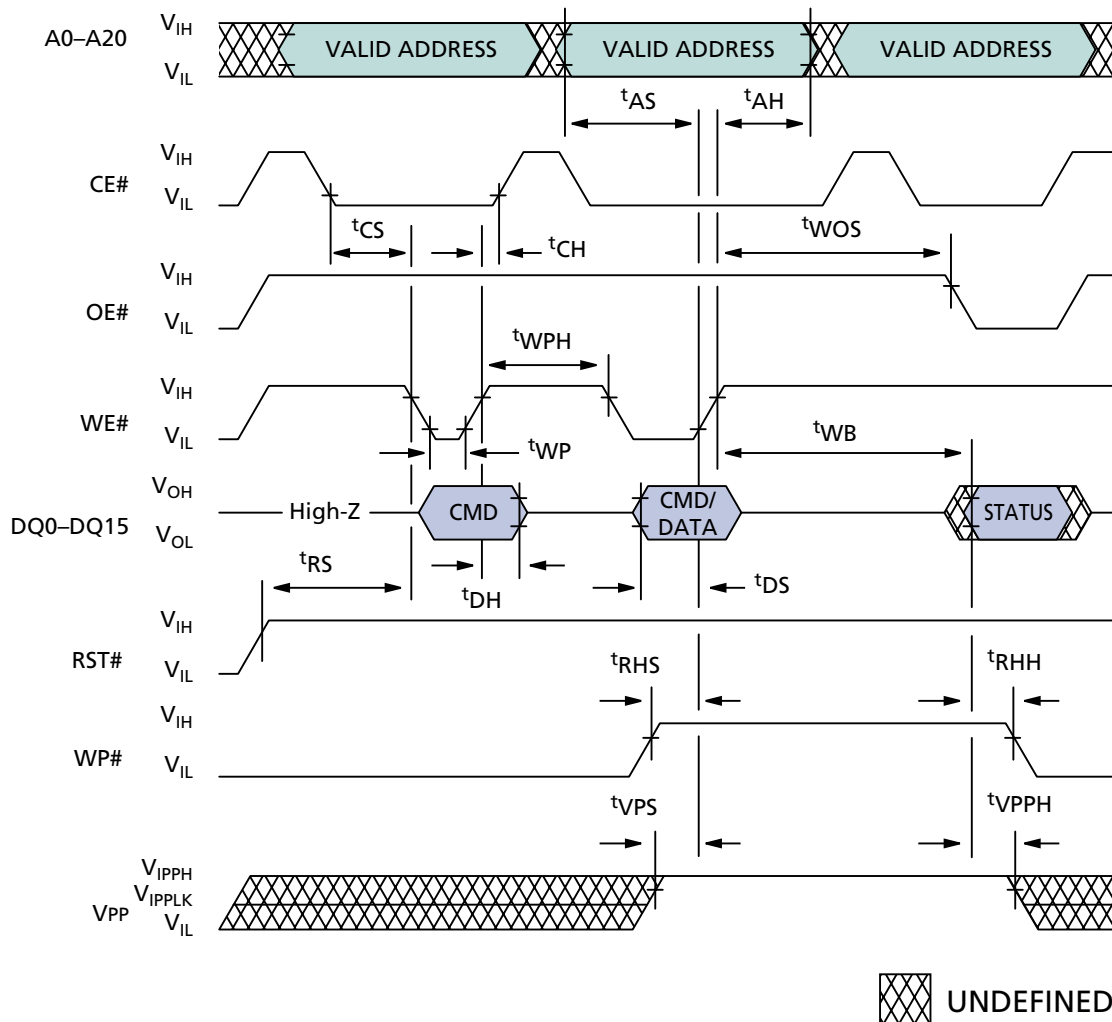

WRITE TIMING PARAMETERS

SYMBOL	-70/-80/-90		UNITS
	MIN	MAX	
t _{RS}	150		ns
t _{CS}	0		ns
t _{WP}	50		ns
t _{DS}	50		ns
t _{AS}	50		ns
t _{CH}	0		ns
t _{DH}	0		ns

SYMBOL	-70/-80/-90		UNITS
	MIN	MAX	
t _{AH}	9		ns
t _{RHS}	0		ns
t _{VPS}	200		ns
t _{WOS}	50		ns
t _{RHH}	0		ns
t _{VPPH}	0		ns
t _{WB}		t _{AA} + 50	ns



RESET OPERATION

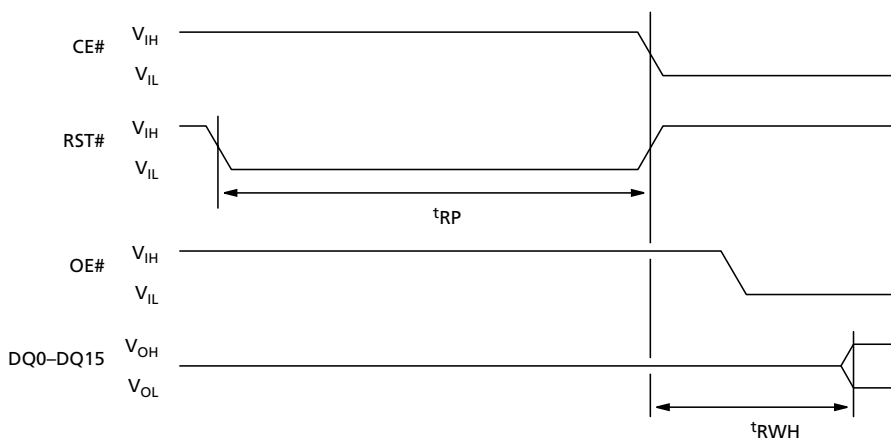

READ AND WRITE TIMING PARAMETERS

SYMBOL	-70/-80		-90		UNITS
	MIN	MAX	MIN	MAX	
t _{RWH}		200		250	ns
t _{RP}	100		100		ns

**Table 11
CFI**

OFFSET	DATA	DESCRIPTION
00	2Ch	Manufacturer code
01	B2h	Top boot block device code
	B3h	Bottom boot block device code
02–0F	reserved	Reserved
10, 11	0051, 0052	“QR”
12	0059	“Y”
13, 14	0003, 0000	Primary OEM command set
15, 16	0039, 0000	Address for primary extended table
17, 18	0000, 0000	Alternate OEM command set
19, 1A	0000, 0000	Address for OEM extended table
1B	0017	V _{CC} MIN for Erase/Write; Bit7–Bit4 Volts in BCD; Bit3–Bit0 100mV in BCD
1C	0022	V _{CC} MAX for Erase/Write; Bit7–Bit4 Volts in BCD; Bit3–Bit0 100mV in BCD
1D	00B4	V _{PP} MIN for Erase/Write; Bit7–Bit4 Volts in Hex; Bit3–Bit0 100mV in BCD
1E	00C6	V _{PP} MAX for Erase/Write; Bit7–Bit4 Volts in Hex; Bit3–Bit0 100mV in BCD
1F	0003	Typical timeout for single byte/word program, 2 ⁿ μs, 0000 = not supported
20	0000	Typical timeout for maximum size multiple byte/word program, 2 ⁿ μs, 0000 = not supported
21	0009	Typical timeout for individual block erase, 2 ⁿ ms, 0000 = not supported
22	0000	Typical timeout for full chip erase, 2 ⁿ ms, 0000 = not supported
23	000C	Maximum timeout for single byte/word program, 2 ⁿ μs, 0000 = not supported
24	0000	Maximum timeout for maximum size multiple byte/word program, 2 ⁿ μs, 0000 = not supported
25	0003	Maximum timeout for individual block erase, 2 ⁿ ms, 0000 = not supported
26	0000	Maximum timeout for full chip erase, 2 ⁿ ms, 0000 = not supported
27	0016	Device size, 2 ⁿ bytes
28	0001	Bus Interface x16 = 1
29	0000	Flash device interface description 0000 = async
2A, 2B	0000, 0000	Maximum number of bytes in multi-byte program or page, 2 ⁿ
2C	0003	Number of erase block regions within device (4K words and 32K words)
2D, 2E	0037, 0000	Top boot block device erase block region information 1, 8 blocks ...
	0007, 0000	Bottom boot block device erase block region information 1, 8 blocks ...
2F, 30	0000, 0001	Top boot block device.....of 8KB
	0020, 0000	Bottom boot block device.....of 8KB
31, 32	0006, 0000	15 blocks of
33, 34	0000, 000164KB

(continued on the next page)



Table 11
CFI (continued)

OFFSET	DATA	DESCRIPTION
35, 36	0007, 0000	Top boot block device.....48 block of
	0037, 0000	Bottom boot block device.....48 block of
37, 38	0020, 0000	Top boot block device.....64KB
	0000, 0001	Bottom boot block device.....64KB
39, 3A	0050, 0052	"PR"
3B	0049	"I"
3C	0030	Major version number, ASCII
3D	0031	Minor version number, ASCII
3E	00E6	Optional Feature and Command Support
3F	0002	Bit 0 Chip erase supported no = 0
40	0000	Bit 1 Suspend erase supported = yes = 1
41	0000	Bit 2 Suspend program supported = yes = 1
		Bit 3 Chip lock/unlock supported = no = 0
		Bit 4 Queued erase supported = no = 0
		Bit 5 Instant individual block locking supported = yes = 1
		Bit 6 Protection bits supported = yes = 1
		Bit 7 Page mode read supported = yes = 1
		Bit 8 Synchronous read supported = no = 0
		Bit 9 Simultaneous operation supported = yes = 1
42	0001	Program supported after erase suspend = yes
43, 44	0003, 0000	Bit 0 block lock status active = yes; Bit 1 block lock down active = yes
45	0018	V _{CC} supply optimum, 00 = not supported, Bit7–Bit4 Volts in BCD; Bit3–Bit0 100mV in BCD
46	00C0	V _{PP} supply optimum, 00 = not supported, Bit7–Bit4 Volts in BCD; Bit3–Bit0 100mV in BCD
47	0001	Number of protection register fields in JEDEC ID space
48, 49	0080, 0000	Lock bytes LOW address, lock bytes HIGH address
4A, 4B	0003, 0003	2 ⁿ factory programmed bytes, 2 ⁿ user programmable bytes
4C	0002	Background Operation 0000 = Not used 0001 = 4% block split 0002 = 12% block split 0003 = 25% block split 0004 = 50% block split
4D	0000	Burst Mode Type 0000 = No burst mode 00x1 = 4 words MAX 00x2 = 8 words MAX 00x3 = 16 words MAX 001x = Linear burst, and/or 002x = Interleaved burst, and/or 004x = Continuous burst

(continued on the next page)

**Table 11
CFI (continued)**

OFFSET	DATA	DESCRIPTION
4E	0002	Page Mode Type 0000 = No page mode 0001 = 4-word page 0002 = 8-word page 0003 = 16-word page 0004 = 32-word page
4F	0000	Not used



48-BALL FBGA

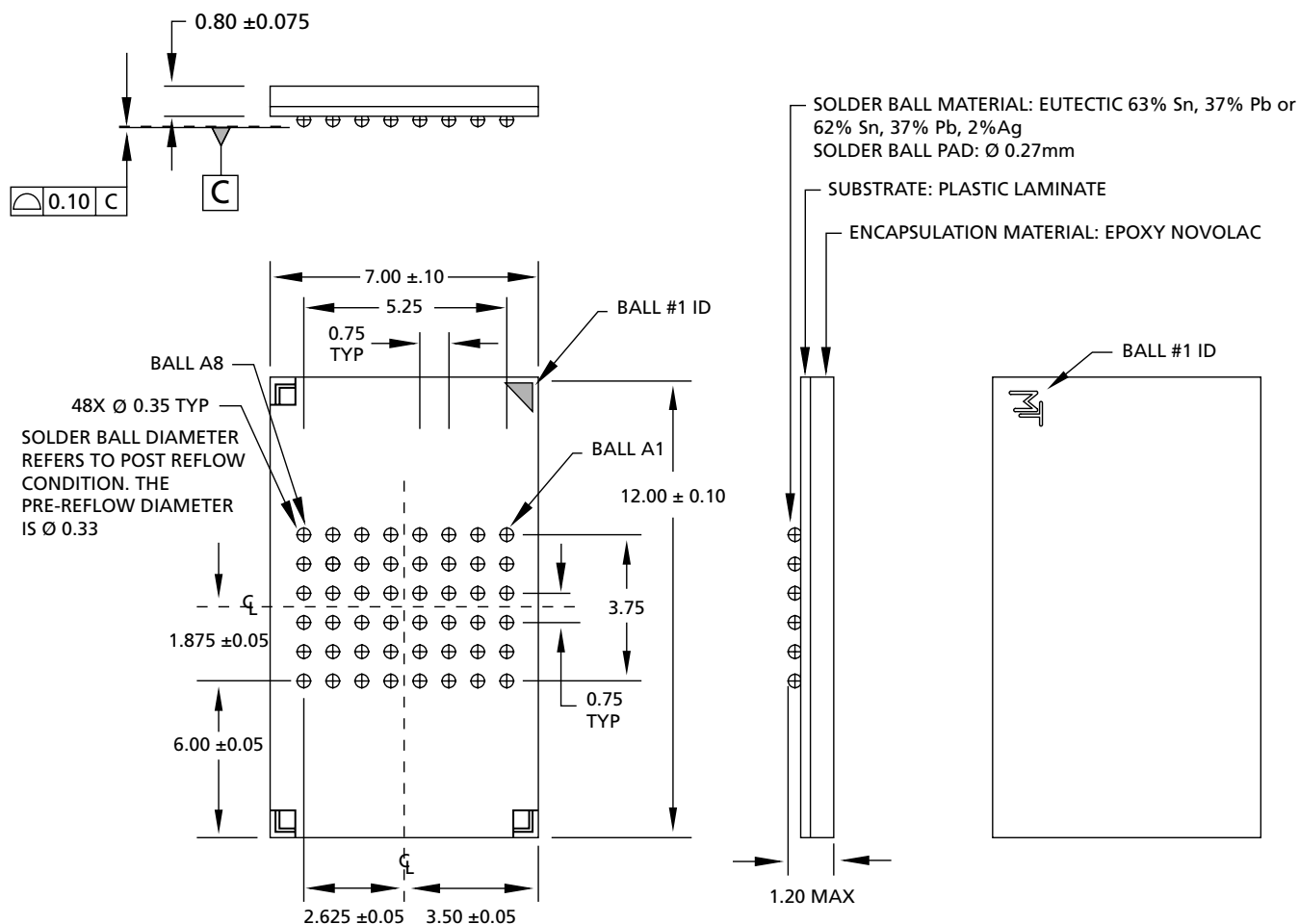

- NOTE:** 1. All dimensions in millimeters.
2. Package width and length do not include mold protrusion; allowable mold protrusion is 0.27mm per side.

DATA SHEET DESIGNATION

Preliminary: This data sheet contains initial characterization limits that are subject to change upon full characterization of production devices.



8000 S. Federal Way, P.O. Box 6, Boise, ID 83707-0006, Tel: 208-368-3900
E-mail: prodmktg@micron.com, Internet: <http://www.micron.com>, Customer Comment Line: 800-932-4992
Micron and the M logo are registered trademarks and the Micron logo is a trademark of Micron Technology, Inc.



REVISION HISTORY

Rev. 3, PRELIMINARY 7/02

- Added Programming the Chip Protection Register section
- Updated Status Register section
- Changed low power consumption voltage from 1.80V to 2.20
- Updated command descriptions
- Updated Read-While-Write/EraseConcurency section
- Updated timing diagrams

Rev. 2, PRELIMINARY 3/02

- Added Notes 2 and 3 to DC Characteristics table

Original document, PRELIMINARY, Rev. 1 1/02