

66133 **3N261**
 3N262
 3N263

SINGLE CHANNEL OPTOCOUPLERS
(REPLACEMENT FOR TIL 120)

Mii
OPTOELECTRONIC PRODUCTS
DIVISION

REVISION A 9/15/00

Features:

- Electrically similar to 4N47, 4N48, 4N49
- Base lead eliminated for improved noise immunity
- Rugged package
- +1kV electrical isolation
- Stability over wide temperature range

Applications:

- Eliminate ground loops
- Level shifting
- Line receiver
- Switching power supplies
- Motor control

DESCRIPTION

The **66133** single channel optocoupler consists of a Gallium Arsenide infrared LED and a high gain N-P-N silicon phototransistor packaged in a hermetically sealed metal case. The **3N261**, **3N262** and **3N263**'s can be tested to customer specifications, as well as to MIL-PRF-19500 using Micropac's extensive in-house test facilities.

ABSOLUTE MAXIMUM RATINGS

Input to Output Voltage	1kV
Emitter-Collector Voltage	7V
Collector-Emitter Voltage (V_{CEO} , $I_F = 0$)	40V
Reverse Input Voltage	2V
Input Diode Continuous Forward Current at (or below) 65°C Free-Air Temperature (see note 1)	40mA
Peak Forward Input Current (Value applies for $t_w \leq 1\mu s$, PRR < 300 pps)	1A
Continuous Collector Current	20mA
Continuous Transistor Power Dissipation at (or below) 25°C Free-Air Temperature (see Note 2)	275mW
Storage Temperature	-65°C to +150°C
Operating Free-Air Temperature Range	-55°C to +100°C
Lead Solder Temperature (10 seconds max.)	240°C

Notes:

1. Derate linearly to 100°C free-air temperature at the rate of 1.14 mA/°C above 65°C.
2. Derate linearly to 100°C free-air temperature at the rate of 7.8 mW/°C above 65°C.

Package Dimensions

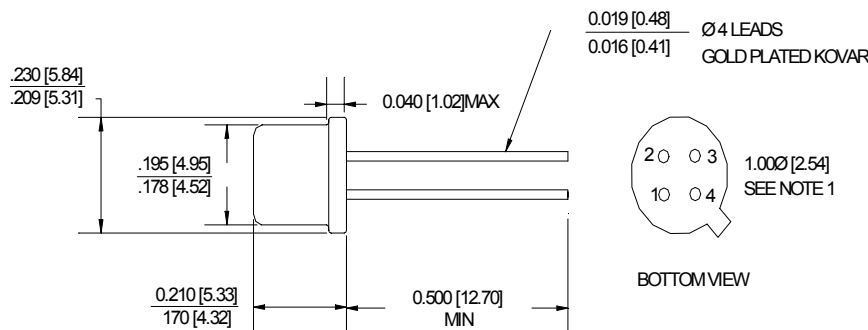

NOTE 1: THIS DIMENSION IS CONTROLLED AT THE HOUSING SURFACE.
 DIMENSIONS ARE IN INCHES [MILLIMETERS]

Schematic Diagram

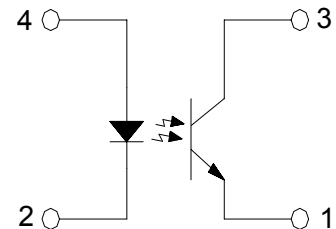

THE COLLECTOR IS IN ELECTRICAL CONTACT WITH THE CASE

REVISION A 9/15/00

ELECTRICAL CHARACTERISTICS

T_A = 25°C

PARAMETER	SYMBOL	MIN	TYP	MAX	UNITS	TEST CONDITIONS
Input Diode Static Reverse Current	I _R			100	μA	V _R = 2V
				100		
				100		
Input Diode Static Forward Voltage	V _F	0.8		1.5	V	I _F = 10mA
		0.8		1.5		
		0.8		1.5		

OUTPUT TRANSISTOR

T_A = 25°C

PARAMETER	SYMBOL	MIN	TYP	MAX	UNITS	TEST CONDITIONS
Collector-Emitter Breakdown Voltage	V _{(BR)CEO}	40			V	I _C = 1mA, I _F = 0
Emitter-Collector Breakdown Voltage	V _{(BR)ECO}	7			V	I _E = 100μA, I _F = 0
Collector Dark Current	I _D			100	nA	V _{CE} = 20V, I _F = 0mA

COUPLED CHARACTERISTICS

T_A = 25°C

PARAMETER	SYMBOL	MIN	TYP	MAX	UNITS	TEST CONDITIONS
On State Collector Current	I _{C(ON)}	0.5			mA	V _{CE} = 5V, I _F = 1mA
On State Collector Current	I _{C(ON)}	1			mA	V _{CE} = 5V, I _F = 1mA
On State Collector Current	I _{C(ON)}	2			mA	V _{CE} = 5V, I _F = 1mA
Collector-Emitter Saturation Voltage	V _{CE(SAT)}			0.3	V	I _F = 2mA, I _C = 0.5mA
	V _{CE(SAT)}			0.3	V	I _F = 2mA, I _C = 1mA
	V _{CE(SAT)}			0.3	V	I _F = 2mA, I _C = 2mA
Rise Time	t _r		10	20	μs	V _{CC} = 10V, I _F = 5mA, R _L = 100Ω
	t _r		10	20	μs	
	t _r		15	25	μs	
Fall Time	t _f		10	20	μs	V _{CC} = 10V, I _F = 5mA, R _L = 100Ω
	t _f		10	20	μs	
	t _f		15	25	μs	

RECOMMENDED OPERATING CONDITIONS:

PARAMETER	SYMBOL	MIN	MAX	UNITS
Input Current, Low Level	I _{FL}	0	1	μA
Input Current, High Level	I _{FH}	10	20	mA
Supply Voltage	V _{CE}	5	10	V

SELECTION GUIDE

PART NUMBER	PART DESCRIPTION
66133-001	3N261, Single Channel Optocoupler, Commercial
66133-002	3N262, Single Channel Optocoupler, Commercial
66133-003	3N263, Single Channel Optocoupler, Commercial
66133-101	3N261, Single Channel Optocoupler with JTX screening
66133-102	3N262, Single Channel Optocoupler with JTX screening
66133-103	3N263, Single Channel Optocoupler with JTX screening