

MITSUBISHI (OPTICAL DEVICES)

FU-68PDF-V520MxxxB

**1.58 μm (L-Band) DFB-LD MODULE WITH POLARIZATION MAINTAINING FIBER PIGTAIL
(WAVELENGTH SELECTED, BIAS CIRCUIT INTEGRATED, DIGITAL APPLICATION)**

DESCRIPTION

Module type FU-68PDF-V520MxxxB is a 1.58 μm (L-Band) DFB-LD module with polarization maintaining optical fiber.

This module is suitable to a CW light source for external modulator for use in 2.5Gb/s and 10Gb/s digital optical communication systems.

This module is prepared to expand the wavelength channels into L-Band for Dense-WDM transmission.

FEATURES

- Multi quantum wells (MQW) DFB Laser Diode module (100GHz spacing)
- Input impedance is 25 Ω
- Emission wavelength is in 1.58 μm band
- Polarization maintaining optical fiber pig-tail
- Built-in optical isolator
- Built-in thermal electric cooler
- Butterfly package
- With photodiode for optical output monitor

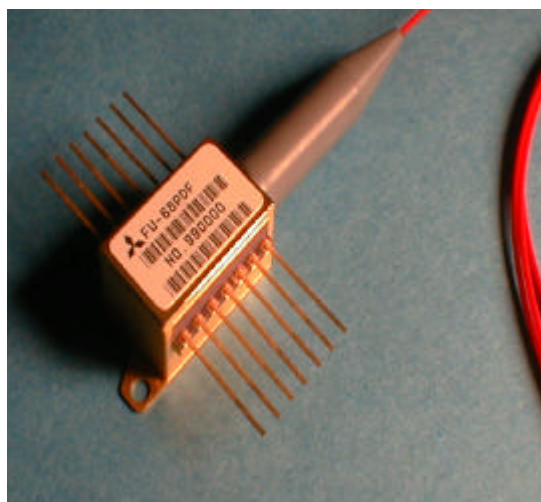

APPLICATION

High speed transmission systems (~10Gb/s)
Dense-WDM systems

OPTION

- Wavelength option:
1565nm~1625nm are available

ABSOLUTE MAXIMUM RATINGS (T_{ld}=T_{set})

Parameter		Symbol	Conditions	Rating	Unit
Laser diode	Optical output power	Pf	CW	24	mW
	Forward current	I _f	CW	150	mA
	Reverse voltage	V _{rl}	-	2	V
Photodiode	Reverse voltage	V _{rd}	-	20	V
	Forward current	I _{fd}	-	2	mA
Thermo-electric cooler (Note)	Cooler current	I _{pe}	-	1.3	A
	Cooler voltage	V _{pe}	-	3.1	V
Operating case temperature		T _c	-	-20 ~ 70	°C
Storage temperature		T _{stg}	-	-40 ~ 85	°C

Note) Even if the thermo-electric cooler (TEC) is operated within the rated conditions, uncontrolled current loading or operation without heatsink may easily damage the module by exceeding the storage temperature range. Thermistor resistance should be properly monitored by the feedback circuit during TEC operation to avoid the catastrophic damage.

FU-68PDF-V520MxxxB

**1.58 μm (L-Band) DFB-LD MODULE WITH POLARIZATION MAINTAINING FIBER PIGTAIL
(WAVELENGTH SELECTED, BIAS CIRCUIT INTEGRATED, DIGITAL APPLICATION)**

ELECTRICAL/OPTICAL CHARACTERISTICS (T_{ld}=T_{set}, T_c=25°C unless otherwise noted)

Parameter	Symbol	Test Conditions	Limits			Unit
			Min.	Typ.	Max.	
Threshold current	I _{th}	CW	-	10	25	mA
Operating current	I _{op}	CW, P _f =20mW	-	-	130	mA
Operating voltage	V _{op}	CW, P _f =20mW	-	-	2	V
Input impedance	Z _{in}	P _f =20mW	-	25	-	W
Light-emission central wavelength	λ_c	CW, P _f =20mW	(Note 1)			nm
Central wavelength drift with case temp.	$\Delta\lambda_c/\Delta T_c$	T _c =-20~70°C	-1	-	0	pm/°C
Laser operating temperature	T _{set}	-	15	-	35	°C
Spectral line width	Δf	CW, P _f =20mW	-	-	20	MHz
Side mode suppression ratio	S _r	CW, P _f =20mW	33	40	-	dB
Cutoff frequency (-1.5dB optical)	f _c	P _f =20mW	2	-	-	GHz
Polarization extinction ratio	E _x	CW, P _f =20mW	20	25	-	dB
Relative intensity noise	N _r	CW, P _f =20mW, 0.5~3GHz	-	-155	-145	dB/Hz
Tracking error (Note 2)	E _r	T _c =-20~70°C, APC, ATC	-	-	0.5	dB
Differential efficiency	η	CW, P _f =20mW	0.15	-	-	mW/ mA
Monitor current	I _{mon}	CW, P _f =20mW, V _{rd} =5V	0.2	-	4	mA
Optical isolation	I _{so}	T _c =25°C	35	-	-	dB
		T _c =-20~70°C	23	-	-	
Dark current (PD)	I _d	V _{rd} =5V, T _c =-20~70°C	-	-	0.1	μA
Capacitance (PD)	C _t	V _{rd} =5V, f=1MHz	-	-	10	pF

Note 1) See Table 1.

Note 2) $E_r = \max\{10 \times \log(P_f / P_{f@25^\circ\text{C}})\}$

FU-68PDF-V520MxxxB

**1.58 μm (L-Band) DFB-LD MODULE WITH POLARIZATION MAINTAINING FIBER PIGTAIL
(WAVELENGTH SELECTED, BIAS CIRCUIT INTEGRATED, DIGITAL APPLICATION)**

THERMAL CHARACTERISTICS (T_{ld}=T_{set}, T_c=-20~70°C)

Parameter	Symbol	Test Conditions	Limits			Unit
			Min.	Typ.	Max.	
Thermistor resistance	R _{th}	T _{ld} =25°C	9.5	10	10.5	k W
B constant of R _{th}	B	-	-	3950	-	K
Cooling capacity	ΔT	P _f =20mW, T _c =70°C	55	-	-	°C
Cooler current	I _{pe}	P _f =20mW, T _c =65°C, T _{ld} =T _{set}	-	0.7	1	A
		P _f =20mW, T _c =70°C, T _{ld} =T _{set}	-	0.9	1.2	A
Cooler voltage	V _{pe}	P _f =20mW, T _c =65°C, T _{ld} =T _{set}	-	1.4	2.3	V
		P _f =20mW, T _c =70°C, T _{ld} =T _{set}	-	2	2.6	V

FIBER PIGTAIL SPECIFICATIONS

Parameter	Limits	Unit
Type	PM (Note 3)	-
Mode field diameter	11+/-1	μm
Cladding diameter	125+/-3	μm
Secondary coating outer diameter	0.9+/-0.1	mm
Polarization axis	slow axis	-
Connector	FC/PC	-
Optical return loss of connector	40 (min)	dB

Note 3) PMF - Sumitomo Panda fiber (PM-155)

DOCUMENTATION (T_{ld}=T_{set})

- Fiber output power vs. Laser forward current at T_{ld}=T_{set} and T_c=-20,25,70°C
- Threshold current (I_{th})
- Laser forward current (I_{op}) at P_f=20mW
- Laser forward voltage (V_{op}) at P_f=20mW
- Laser operating temperature (T_{set}) at λ_c (Note 4)
- Monitor current (I_{mon}) at P_f=20mW
- Thermistor resistance (R_{th})
- Cooler current (I_{pe}) at P_f=20mW and T_c=70°C
- Cooler voltage (V_{pe}) at P_f=20mW and T_c=70°C

Note 4) T_{set} is attached as a reference data. R_{th} should be used in order to tune the wavelength to the specified value accurately.

FU-68PDF-V520MxxxB

**1.58 μm (L-Band) DFB-LD MODULE WITH POLARIZATION MAINTAINING FIBER PIGTAIL
(WAVELENGTH SELECTED, BIAS CIRCUIT INTEGRATED, DIGITAL APPLICATION)**

Table 1.

Type number	λ_c (nm)	Type number	λ_c (nm)	Type number	λ_c (nm)
FU-68PDF-V520M103B	1567.13	FU-68PDF-V520M139B	1582.02	FU-68PDF-V520M175B	1597.19
FU-68PDF-V520M104B	1567.54	FU-68PDF-V520M140B	1582.44	FU-68PDF-V520M176B	1597.62
FU-68PDF-V520M105B	1567.95	FU-68PDF-V520M141B	1582.85	FU-68PDF-V520M177B	1598.04
FU-68PDF-V520M106B	1568.36	FU-68PDF-V520M142B	1583.27	FU-68PDF-V520M178B	1598.47
FU-68PDF-V520M107B	1568.77	FU-68PDF-V520M143B	1583.69	FU-68PDF-V520M179B	1598.89
FU-68PDF-V520M108B	1569.18	FU-68PDF-V520M144B	1584.11	FU-68PDF-V520M180B	1599.32
FU-68PDF-V520M109B	1569.59	FU-68PDF-V520M145B	1584.53	FU-68PDF-V520M181B	1599.75
FU-68PDF-V520M110B	1570.01	FU-68PDF-V520M146B	1584.95	FU-68PDF-V520M182B	1600.17
FU-68PDF-V520M111B	1570.42	FU-68PDF-V520M147B	1585.36	FU-68PDF-V520M183B	1600.60
FU-68PDF-V520M112B	1570.83	FU-68PDF-V520M148B	1585.78	FU-68PDF-V520M184B	1601.03
FU-68PDF-V520M113B	1571.24	FU-68PDF-V520M149B	1586.20	FU-68PDF-V520M185B	1601.46
FU-68PDF-V520M114B	1571.65	FU-68PDF-V520M150B	1586.62	FU-68PDF-V520M186B	1601.88
FU-68PDF-V520M115B	1572.06	FU-68PDF-V520M151B	1587.04	FU-68PDF-V520M187B	1602.31
FU-68PDF-V520M116B	1572.48	FU-68PDF-V520M152B	1587.46	FU-68PDF-V520M188B	1602.74
FU-68PDF-V520M117B	1572.89	FU-68PDF-V520M153B	1587.88	FU-68PDF-V520M189B	1603.17
FU-68PDF-V520M118B	1573.30	FU-68PDF-V520M154B	1588.30	FU-68PDF-V520M190B	1603.60
FU-68PDF-V520M119B	1573.71	FU-68PDF-V520M155B	1588.73	FU-68PDF-V520M191B	1604.03
FU-68PDF-V520M120B	1574.13	FU-68PDF-V520M156B	1589.15	FU-68PDF-V520M192B	1604.46
FU-68PDF-V520M121B	1574.54	FU-68PDF-V520M157B	1589.57	FU-68PDF-V520M193B	1604.88
FU-68PDF-V520M122B	1574.95	FU-68PDF-V520M158B	1589.99	FU-68PDF-V520M194B	1605.31
FU-68PDF-V520M123B	1575.37	FU-68PDF-V520M159B	1590.41	FU-68PDF-V520M195B	1605.74
FU-68PDF-V520M124B	1575.78	FU-68PDF-V520M160B	1590.83	FU-68PDF-V520M196B	1606.17
FU-68PDF-V520M125B	1576.20	FU-68PDF-V520M161B	1591.26	FU-68PDF-V520M197B	1606.60
FU-68PDF-V520M126B	1576.61	FU-68PDF-V520M162B	1591.68	FU-68PDF-V520M198B	1607.04
FU-68PDF-V520M127B	1577.03	FU-68PDF-V520M163B	1592.10	FU-68PDF-V520M199B	1607.47
FU-68PDF-V520M128B	1577.44	FU-68PDF-V520M164B	1592.52	FU-68PDF-V520M200B	1607.90
FU-68PDF-V520M129B	1577.86	FU-68PDF-V520M165B	1592.95	FU-68PDF-V520M201B	1608.33
FU-68PDF-V520M130B	1578.27	FU-68PDF-V520M166B	1593.37	FU-68PDF-V520M202B	1608.76
FU-68PDF-V520M131B	1578.69	FU-68PDF-V520M167B	1593.79	FU-68PDF-V520M203B	1609.19
FU-68PDF-V520M132B	1579.10	FU-68PDF-V520M168B	1594.22	FU-68PDF-V520M204B	1609.62
FU-68PDF-V520M133B	1579.52	FU-68PDF-V520M169B	1594.64	FU-68PDF-V520M205B	1610.06
FU-68PDF-V520M134B	1579.93	FU-68PDF-V520M170B	1595.06	FU-68PDF-V520M206B	1610.49
FU-68PDF-V520M135B	1580.35	FU-68PDF-V520M171B	1595.49	FU-68PDF-V520M207B	1610.92
FU-68PDF-V520M136B	1580.77	FU-68PDF-V520M172B	1595.91	FU-68PDF-V520M208B	1611.35
FU-68PDF-V520M137B	1581.18	FU-68PDF-V520M173B	1596.34	FU-68PDF-V520M209B	1611.79
FU-68PDF-V520M138B	1581.60	FU-68PDF-V520M174B	1596.76		

All wavelengths are referred to vacuum.

Tolerance is $\lambda_c \pm 0.05\text{nm}$.

MITSUBISHI (OPTICAL DEVICES)

FU-68PDF-V520MxxxB

1.58 μm (L-Band) DFB-LD MODULE WITH POLARIZATION MAINTAINING FIBER PIGTAIL
(WAVELENGTH SELECTED, BIAS CIRCUIT INTEGRATED, DIGITAL APPLICATION)

OUTLINE DIAGRAM

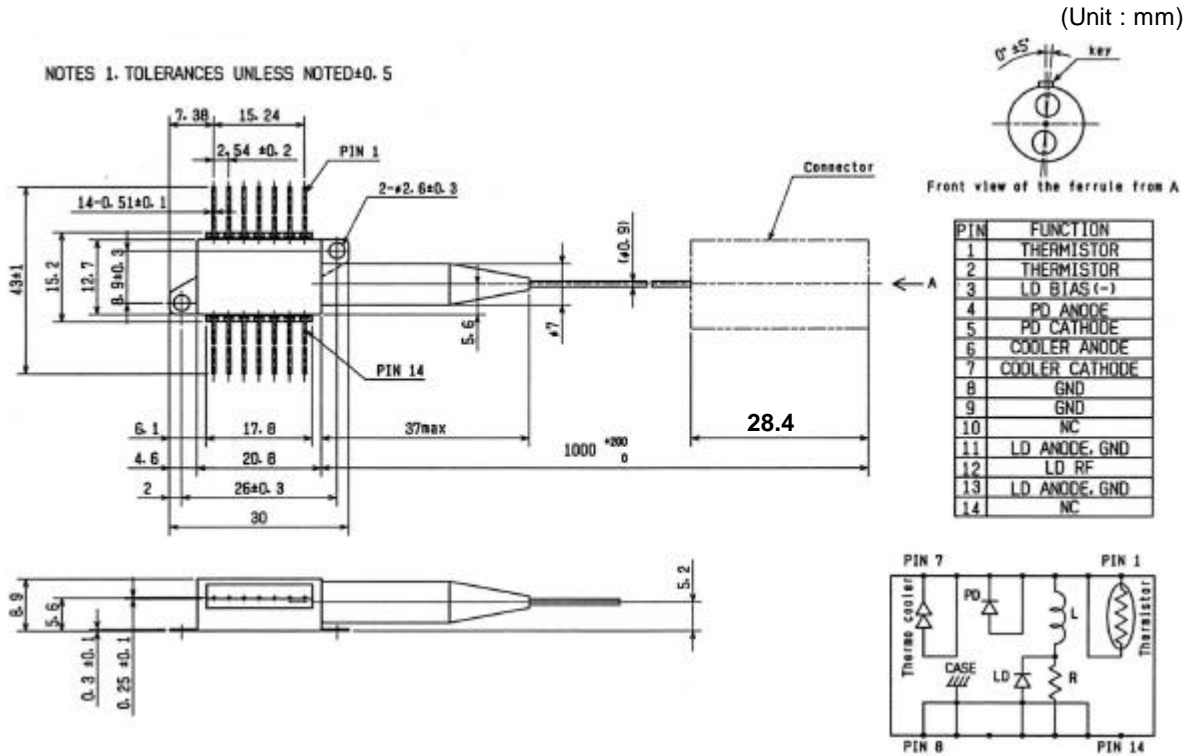

FU-68PDF-V520MxxxB