

PRELIMINARY
 Notice ; This is not a final specification.
 some parametric limits are subject to change

MITSUBISHI SOUND PROCESSORS

M615XXFP

Digital controlled Sound Controller

Tone and Volume controller with 6ch selector

APPLICATION

Mini Stereo / AV Amplifier / TV

FEATURE

- ◆ Input Selector (6ch+MUTE)
- ◆ Input ATT (-5dB) [ON/OFF]
- ◆ Tone ATT (-8dB,-13dB)
- ◆ 5 Band Tone Control
 - 3 Band resonate type
 - L , H Band shelving type(LPF,HPF type)
- ◆ Master Volume 1dB step, 2ch independent control
(2ch 0 to -79dB,mute) L , R ch
- ◆ Trim Volume 1dB step, 2ch independent control
(2ch 0 to -15dB) L , R ch
- ◆ SURROUND Volume 6 step(0 to -10dB)
- ◆ Multiple sound select(REC OUT) [L/Ronly]
- ◆ DPL Input Select
- ◆ REC Output 2ch(Between 1ch with MUTE)
- ◆ Output for Spectrum Analyzer (L+R/2)
- ◆ Correspond to Key control
- ◆ Bass Boost circuit [ON/OFF]
- ◆ Super Woofer Output
- ◆ Sound Effect circuit (Sound clearly)
- ◆ Power Supply : \pm power and Single power available (When use single power , need the power for reference)

Package Outline

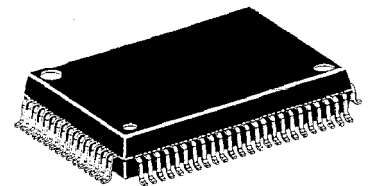

80P6N

lead pitch : 0.8 mm

size : 20.0mm x 14.0mm x 2.8mm

RECOMMENDED OPERATION VOLTAGE

SUPPLY VOLTAGE RANGE : \pm 4.0 to \pm 5.0V [Single power 8.0 to 10.0V]

FUNCTION BLOCK DIAGRAM

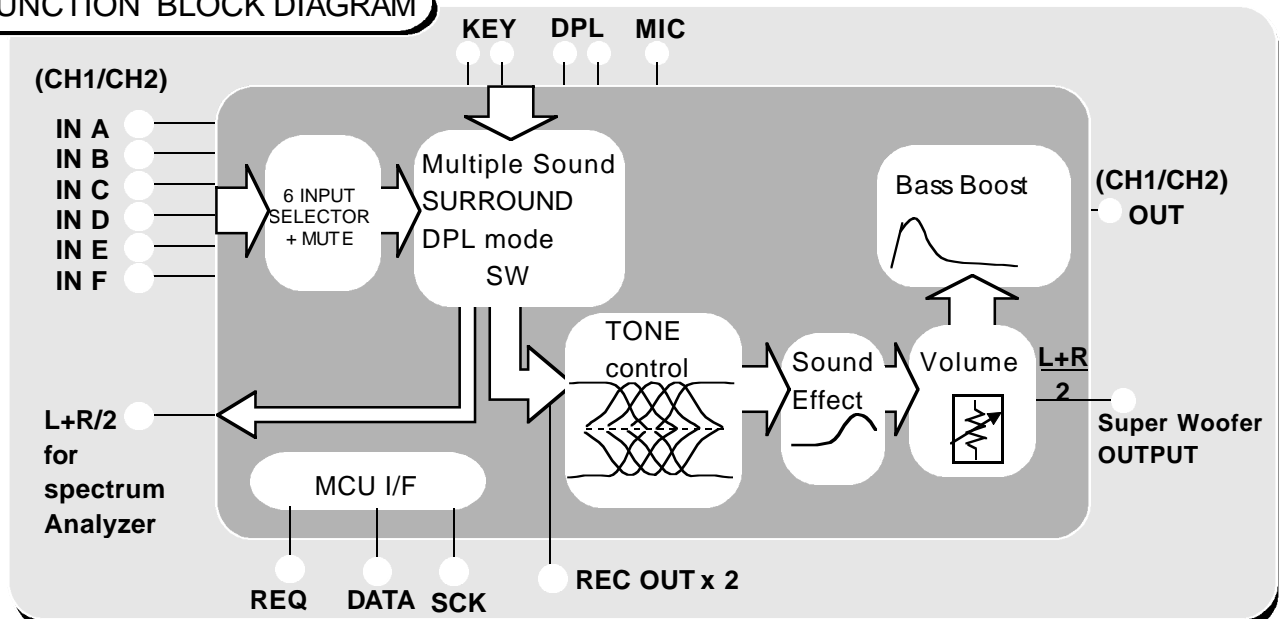

PRELIMINARY
 Notice ; This is not a final specification.
 Some parametric limits are subject to change

M615XFP

Digital controlled Sound Controller

BLOCK
 DIAGRAM

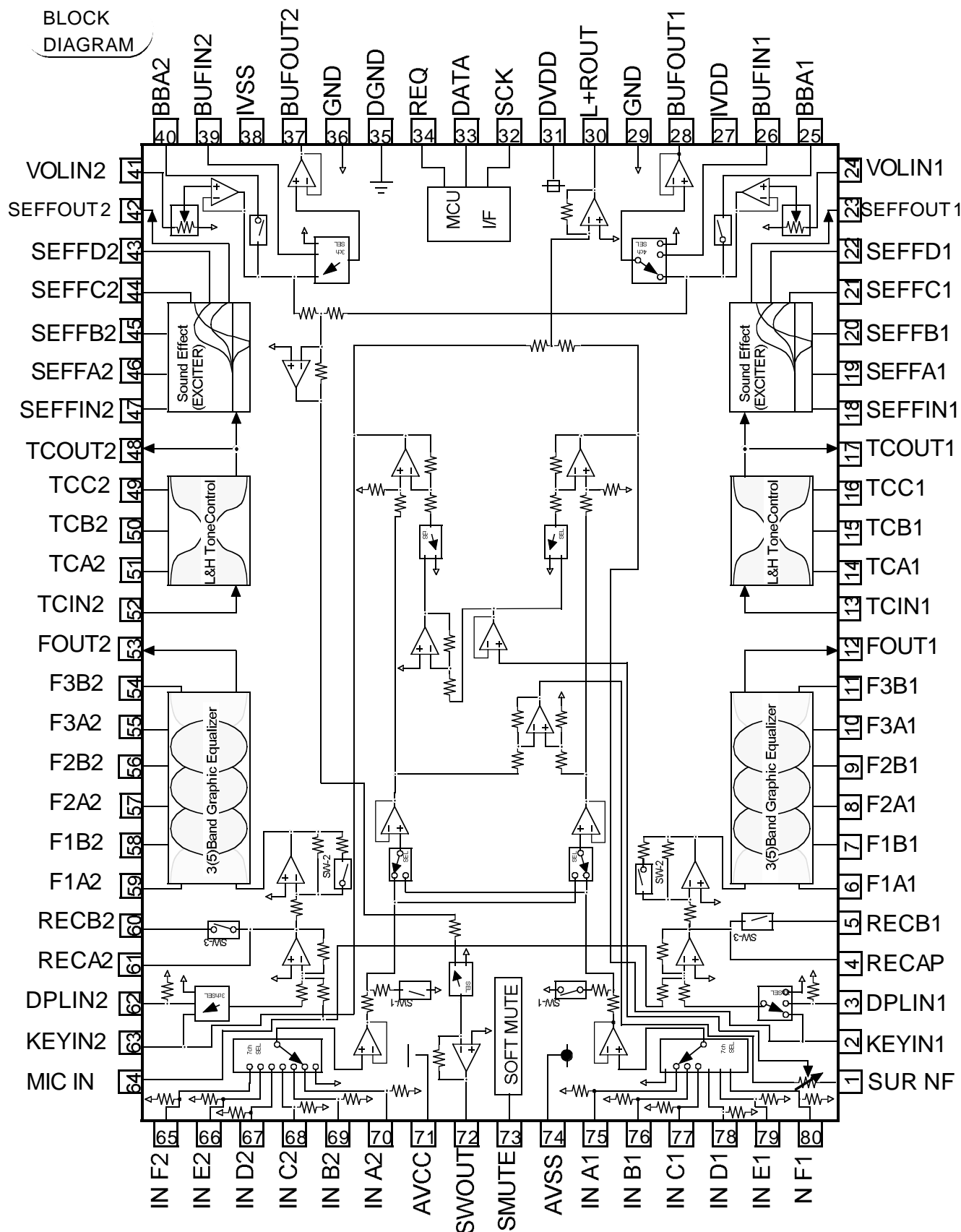

PRELIMINARY
 Notice ; This is not a final specification.
 some parametric limits are subject to change

M615XXFP

Digital controlled Sound Controller

Electric Characteristics

(1).Absolute Maximum ratings

(Ta=25 °C,AVDD=4.5V,AVSS=-4.5V,DVDD=5.0V ,f=1kHz unless otherwise noted)
 (Normal mode , Tone control and Bass boost controlled 0dB)

Symbol	Parameter	Conditions	Ratings	Units
Vcc	Supply Voltage		± 5.25 (10.5)	V
VDD			6.5	V
Pd	Power Dissipation		1.4	W
Topr	Operating Temperature		-20 to +75	C
Tstg	Storage Temperature		-40 to +125	C

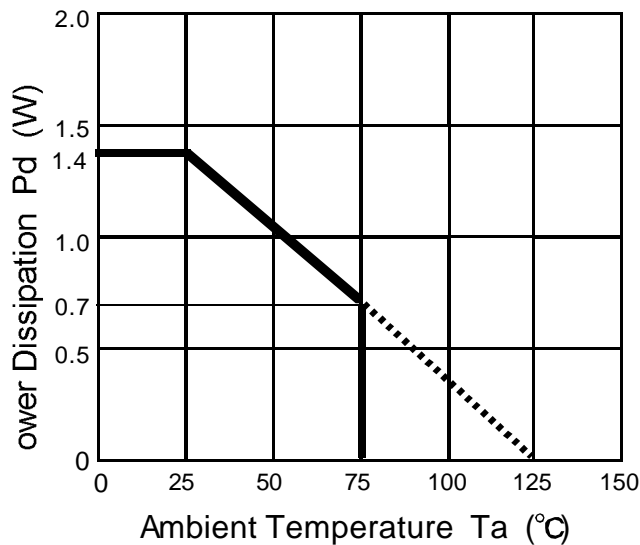

(2)RECommended Operating Condition

Parameter	symbol	Test conditions	Limits			Units
			Min	typ	Max	
Analog positive supply current	AICC	AVCC=4.5V, AVSS= -4.5V 71pin current No signal	—	30	50	mA
Analog negative supply current	AISS	AVCC=4.5V, AVSS= -4.5V 74pin current No signal	-50	-30	—	mA
Digital supply current	DIdd	DVDD= 5V 31pin current No signal	—	0.5	1.0	mA

PRELIMINARY
 Notice ; This is not a final specification.
 some parametric limits are subject to change

M615XXFP

Digital controlled Sound Controller

(3) Characteristics of output /input

($T_a=25\text{ }^\circ\text{C}$, $AVDD=4.5\text{V}$, $AVSS=-4.5\text{V}$, $DVDD=5.0\text{V}$, $f=1\text{kHz}$ unless otherwise noted)
 (Normal mode , Tone control and Bass boost controlled 0dB)

Parameter	symbol	Test conditions	Limits			Units	
			Min	typ	Max		
Input Resistance	Rin	75pin,70Pin	40	60	80	K Ω	
Maximum Output Voltage	VIM	(75,70)pin Input,(28,37)pin Output RL =10K Ω , THD=1%	1.5	1.8	—	Vrms	
Output terminal Voltage	Vodc	28pin,37pin, No signal	-0.4	0.0	0.4	V	
	VRECdc	4pin,61pin, No signal	-0.4	0.0	0.4	V	
Through Gain	Gv	Vin=1Vrms,FLAT,(75,70pin) - (28,37pin)gain	-10.0	-8.0	-6.0	dB	
Maximum Attenuation	ATT	Vo=1Vrms,28,37pin JIS-A filter	—	-85	-77	dB	
Output Noise Voltage	Vono	JIS-A filter No signal,Rg=10K	28,37pin	—	4.0	10.0	μVrms
	VRECno	FLAT(pass)	4,61pin	—	4.0	8.0	μVrms
Distortion	THD	28pin,37pin, BW=400 to 30kHz Vo=300mVrms , RL=10K Ω	—	0.01	0.05	%	
	THDRECA	4pin,61pin, BW=400 to 30kHz Vo=300mVrms , RL=30K Ω	—	0.01	0.05	%	
	THDRECB	5pin,60pin, BW=400 to 30kHz Vo=300mVrms , RL=51K Ω	—	0.01	0.05	%	
Channel cross-talk	CT	Vo=0.5Vrms , RL=10K Ω ,JIS-A 28pin-37pin Rg=10K Ω	—	-70	-55	dB	
	CTREC	Vo=0.5Vrms , RL=30K Ω ,JIS-A 4pin-61pin Rg=10K Ω	—	-70	-55	dB	

PRELIMINARY
 Notice ; This is not a final specification.
 Some parametric limits are subject to change

M615XXFP

Digital controlled Sound Controller

(4)TONE CONTROL CHARACTERISTICS

Parameter	symbol		Test conditions	Limits			Units
				Min	typ	Max	
LO Tone Output Gain	GboostL	LO	+13dB	10	13	16	dB
	GcutL	LO	-13dB	-10	-13	-16	dB
Tone Output Gain	Gboost*	F1 to F3	+8 dB	6	8	10	dB
	Gcut*	F1 to F3	-8 dB	-6	-8	-10	dB
HI Tone Output Gain	GboostH	HI	+8 dB	6	8	10	dB
	GcutH	HI	-8 dB	-6	-8	-10	dB
Channel Balance	BALton		f=1KHz,Vo=1Vrms,6,59pin Input, 21,44pin Output each Boost +8,-6dB	-1.5	0	+1.5	dB

(5)CH1 / CH2 Mix Signal

(This character is regulated only one channel input.)

Parameter		symbol	Test conditions	Limits			Units
				Min	typ	Max	
Super Woofer Output	Gain	GvSW	The same condition Gv RL=30KΩ	-8.0	-6.0	-4.0	dB
	Distortion	THDSW	BW=400 to 30kHz Vo=0.5Vrms , RL=30KΩ	—	0.03	0.15	%
	Output Noise Voltage	VnoSW	No signal: JIS-A filter The same condition Vono	—	50	100	μVrms
(L+R)/2(spectrum)output gain		GvLR	The same condition Gv RL=51KΩ	-8.0	-6.0	-4.0	dB

*In case of CH1,CH2 same phase,same amplitude,output gain is 0dB.

PRELIMINARY
 Notice ; This is not a final specification.
 Some parametric limits are subject to change

M615XXFP

Digital controlled Sound Controller

INPUT DATA FORMAT

DATA is read at the rising edge of SCK, and loaded last 16 bits at the rising edge of REQ.

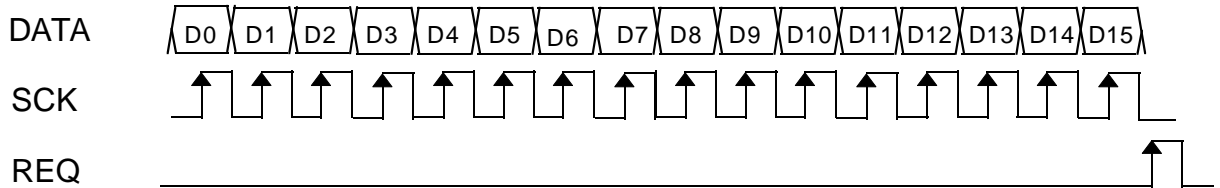

(Please all data of 4 format initialize at Power supply.)

	D0	D1	D2	D3	D4	D5	D6	D7	D8	D9	D10	D11	D12	D13	D14	D15
A	0	0	'(1) INPUT Selector			'(2)	'(3)	'(4) Multiple Sound		'(5)	'(6)	'(7) SURROUND ATT				
B	0	1	'(8) TONE Selector			'(9) TONE control				'(10)	'(11)	'(12) Sound Effect				
C	1	0	'(16)	(13)-L Lch Trim Volume			(14)-L Lch ShiftVolume		(15)-L Lch Master Volume				Chip Address 1 1			
D	1	1	'(17)	(13)-R Rch Trim Volume			(14)-R Rch ShiftVolume		(15)-R Rch Master Volume							

(1)INPUT SELECTOR

INPUT SEL	D2A	D3A	D4A
A	0	0	0
B	0	0	1
C	0	1	0
D	0	1	1
E	1	0	0
F	1	0	1
MUTE	1	1	1

(2)INPUT ATT

INPUT ATT	D5A	SW-1
0dB	0	OFF
-5dB	1	ON

(3)Tone ATT

TONE ATT	D6A	SW-2
-8dB	0	OFF
-13dB	1	ON

(4)Multiple Sound

CH SEL.	D7A	D8A
NORMAL	0	0
CH1 ONLY	0	1
CH2 ONLY	1	0
(CH1<->CH2)	1	1

(5)SURROUND / Normal

SEL	D9A
NORMAL	0
SURROUND	1

(6)REC B MUTE

REC B	D10A	SW-3
THRU	0	ON
MUTE	1	OFF

(7)SURROUND ATT

INPUT SEL	D11A	D12A	D13A
0dB	0	0	0
-1dB	0	0	1
-2dB	0	1	0
-4dB	0	1	1
-6dB	1	0	0
-10dB	1	0	1

(11)DPL Selector

DPL SEL.	D10B
THRU	0
DPL	1

* Don't Input the Illegal DATA.

PRELIMINARY
 Notice ; This is not a final specification.
 Some parametric limits are subject to change

M615XXFP

Digital controlled Sound Controller

(8) TONE Selector

TONE SEL.	D2B	D3B	D4B
LO TONE	0	0	0
TONE1(F1)	0	0	1
TONE2(F2)	0	1	0
TONE3(F3)	0	1	1
HI TONE	1	0	0
ALL BAND	1	1	1

(10) Bass Boost

Bus Boost	D9B
No Boost	0
Boost ON	1

(9) Tone control

LO	F1-F3,HI	D8B	D7B	D6B	D5B
+13dB	+8dB	1	1	0	0
+9dB	+6dB	1	0	1	1
+6dB	+4dB	1	0	1	0
+3dB	+2dB	1	0	0	1
+0dB	+0dB	1	0	0	0
-0dB	-0dB	0	0	0	0
-3dB	-2dB	0	0	0	1
-6dB	-4dB	0	0	1	0
-9dB	-6dB	0	0	1	1
-13dB	-8dB	0	1	0	0

(12) Sound Effect

	TONE SEL.	D13B	D12B	D11B
+phase	0dB	0	0	0
	+3dB	0	0	1
	+6dB	0	1	0
	+9dB	0	1	1
-phase	0dB	1	0	0
	-3dB	1	0	1
	-6dB	1	1	0
	-9dB	1	1	1

* 0dB=Effect through (Both Mode)

(13) Trim Volume(Lch,Rch)

TONE SEL.	D6C,D	D5C,D	D4C,D	D3C,D
0dB	0	0	0	0
-1dB	0	0	0	1
-2dB	0	0	1	0
-3dB	0	0	1	1
-4dB	0	1	0	0
-5dB	0	1	0	1
-6dB	0	1	1	0
-7dB	0	1	1	1
-8dB	1	0	0	0
-9dB	1	0	0	1
-10dB	1	0	1	0
-11dB	1	0	1	1
-12dB	1	1	0	0
-13dB	1	1	0	1
-14dB	1	1	1	0
-15dB	1	1	1	1

(15) Master Volume (Lch,Rch)

ATT	D13C,D	D12C,D	D11C,D	D10C,D	D9C,D
0dB	0	0	0	0	0
-2.0dB	1	0	0	0	0
-4.0dB	0	1	0	0	0
-6.0dB	1	1	0	0	0
-8.0dB	0	0	1	0	0
-10.0dB	1	0	1	0	0
-12.0dB	0	1	1	0	0
-14.0dB	1	1	1	0	0
-16.0dB	0	0	0	1	0
-18.0dB	1	0	0	1	0
-20.0dB	0	1	0	1	0
-22.0dB	1	1	0	1	0
-24.0dB	0	0	1	1	0
-26.0dB	1	0	1	1	0
-28.0dB	0	1	1	1	0
-30.0dB	1	1	1	1	0
-32.0dB	0	0	0	0	1
-34.0dB	1	0	0	0	1
-36.0dB	0	1	0	0	1
-38.0dB	1	1	0	0	1
-40.0dB	0	0	1	0	1
-42.0dB	1	0	1	0	1
-44.0dB	0	1	1	0	1
-48.0dB	1	1	1	0	1
-52.0dB	0	0	0	1	1
-56.0dB	1	0	0	1	1
-60.0dB	0	1	0	1	1
-64.0dB	1	1	0	1	1
-68.0dB	0	0	1	1	1
-72.0dB	1	0	1	1	1
-76.0dB	0	1	1	1	1
MUTE	1	1	1	1	1

(14) Shift Volume(Lch,Rch)

INPUT SEL.	D8C,D	D7C,D
0dB	0	0
-1dB	0	1
-2dB	1	0
-3dB	1	1

(16) All MUTE

DPL	D2C
NO MUTE	0
ALL MUTE	1

(17) SW MUTE

SW	D2D
SWOUT	0
SWMUTE	1

All MUTE condition:
 Master Volume (L,R)=MUTE,
 INPUT SELECTOR=MUTE

* Don't Input the Illegal DATA.

PRELIMINARY
 Notice ; This is not a final specification.
 some parametric limits are subject to change

MITSUBISHI SOUND PROCESSORS

M615XXFP

Digital controlled Sound Controller

DATA TIMING

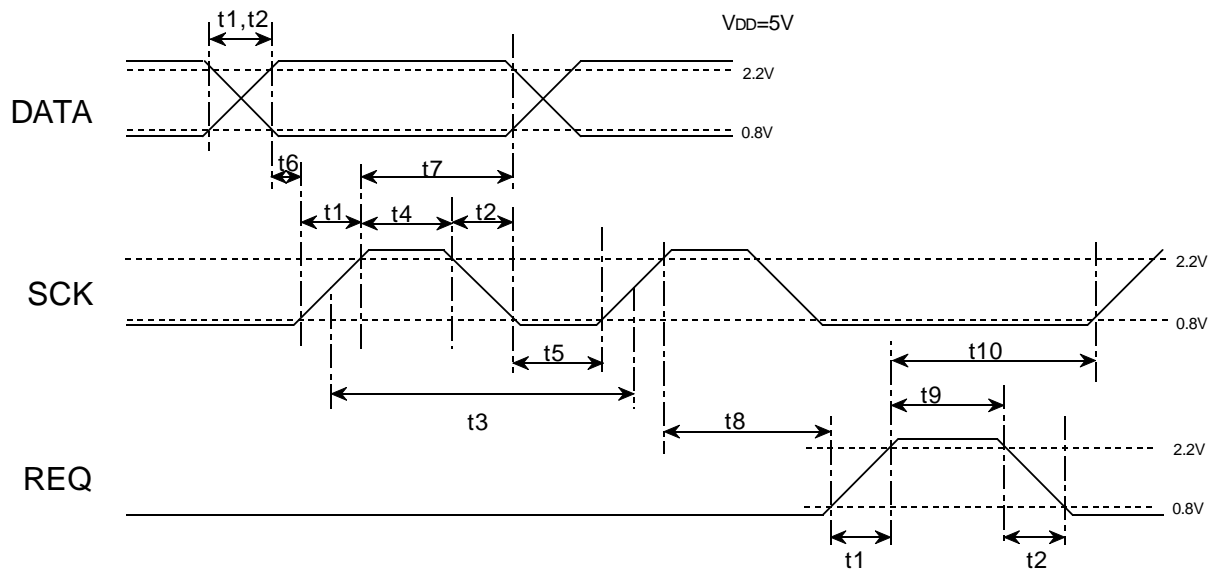

Symbol	Name	Min	Typ	Max	Units
t1	Signal rise time	—	—	0.5	μ S
t2	Signal fall time	—	—	0.5	μ S
t3	SCK clock width	2	—	—	μ S
t4	SCK "H" pulse width	0.8	—	—	μ S
t5	SCK "L" pulse width	0.8	—	—	μ S
t6	DATA setup time	0.8	—	—	μ S
t7	DATA hold time	0.8	—	—	μ S
t8	REQ rise hold time	1.6	—	—	μ S
t9	REQ "H" pulse width	0.8	—	—	μ S
t10	SCK setup time	1.6	—	—	μ S

PRELIMINARY
 Notice ; This is not a final specification.
 Some parametric limits are subject to change

M615XXFP

Digital controlled Sound Controller

DESCRIPTION OF FUNCTION

(1) Input Selector , Input Attenuator

2ch 6 Input+MUTE Selector built-in.

Input Selector is controlled ATT SW.(0dB/-5dB)

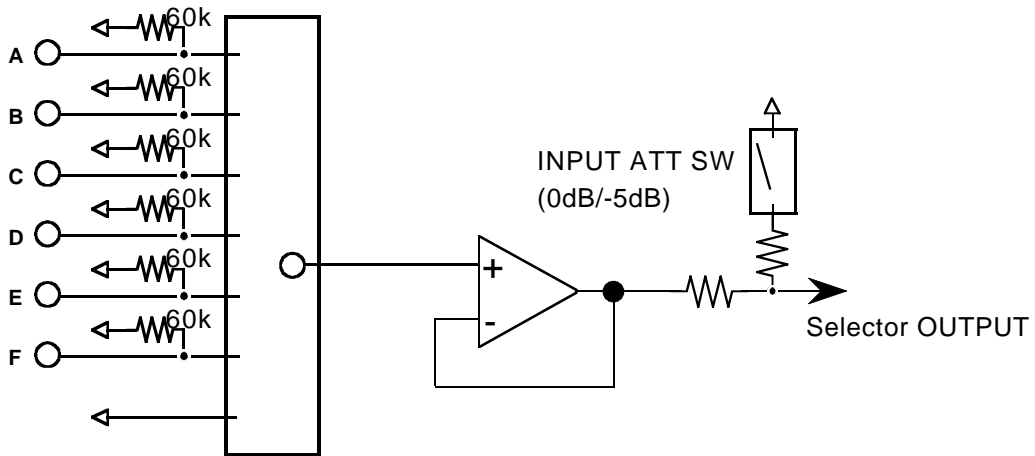

(2) Master Volume(CH1,CH2) , Trim Volume

This IC have 2 channel electric volume, 2 channel independent control.

It has low distortion and low noise.

It is able to control each Master and Trim Volume.

Master Volume : 0dB to -79dB / 1dB step , MUTE

Trim Volume : 0dB to -15dB / 1dB step

Volume output consist of adding Master volume and Trim volume.

In case (Trim) + (Master) under -88dB , TOTAL ATT = -87dB.

Only Master Volume = MUTE , TOTAL ATT = MUTE

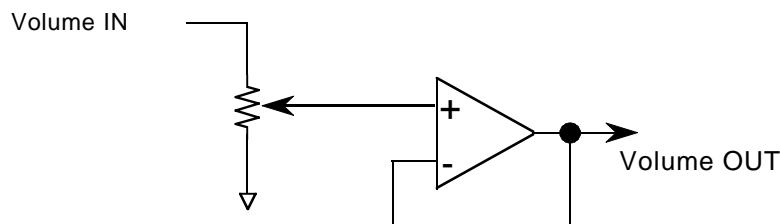

Master Volume: 0dB to -79dB/1dB step , MUTE

Trim Volume : 0dB to -15dB/1dB step

PRELIMINARY
 Notice ; This is not a final specification.
 Some parametric limits are subject to change

M615XXFP

Digital controlled Sound Controller

(3) Tone control circuit

3-1 3Band resonate type (Boost Mode)

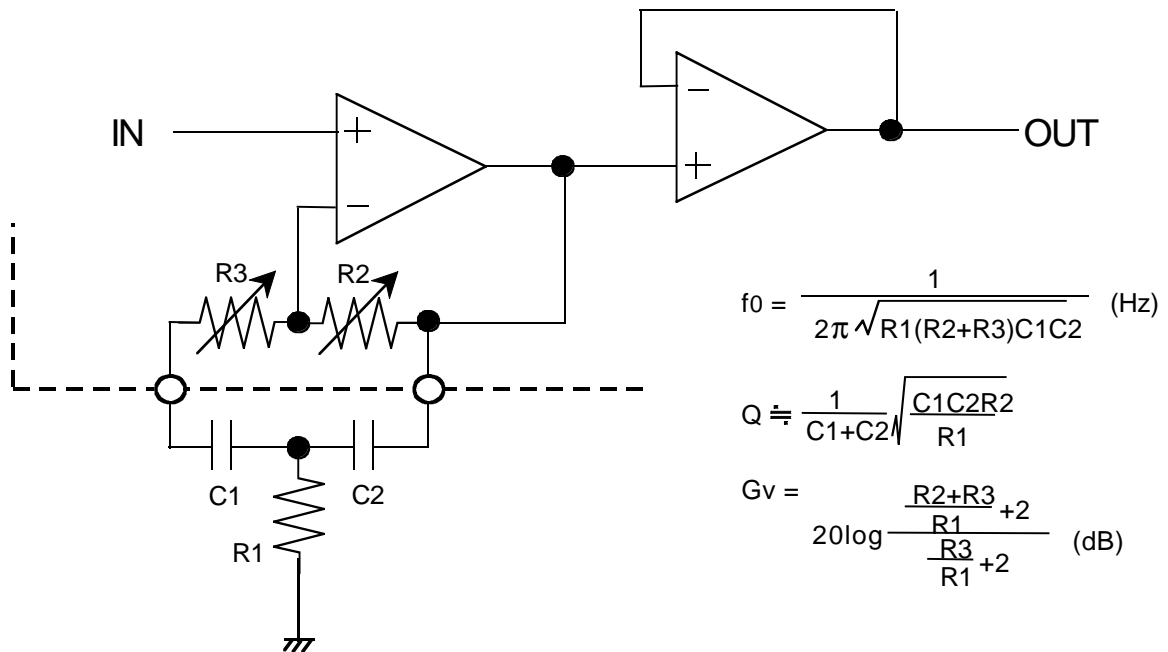

3-2 3Band resonate type (Cut Mode)

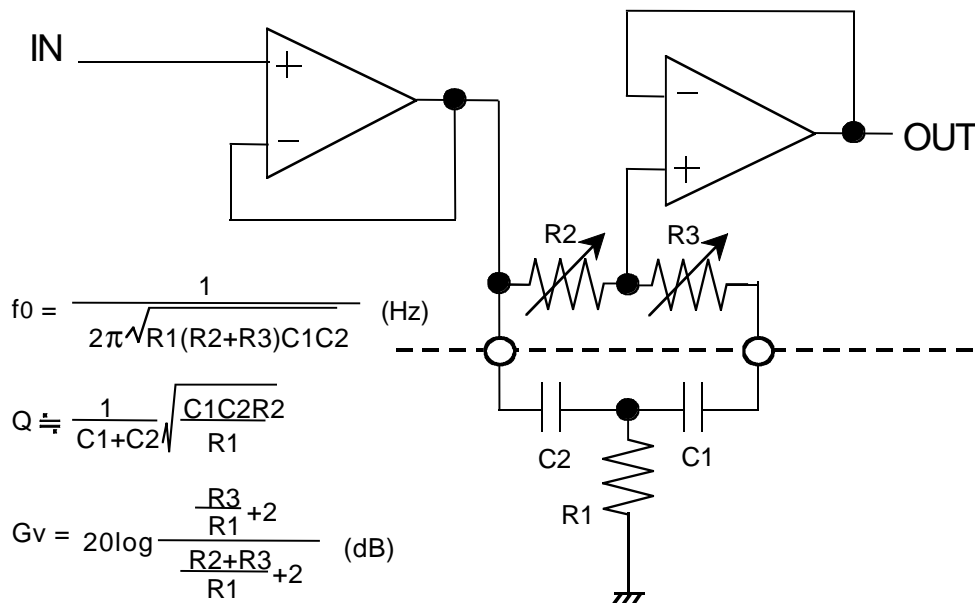

PRELIMINARY
 Notice ; This is not a final specification.
 Some parametric limits are subject to change

MITSUBISHI SOUND PROCESSORS

M615XXFP

Digital controlled Sound Controller

3-3 LO and HI Tone control circuit

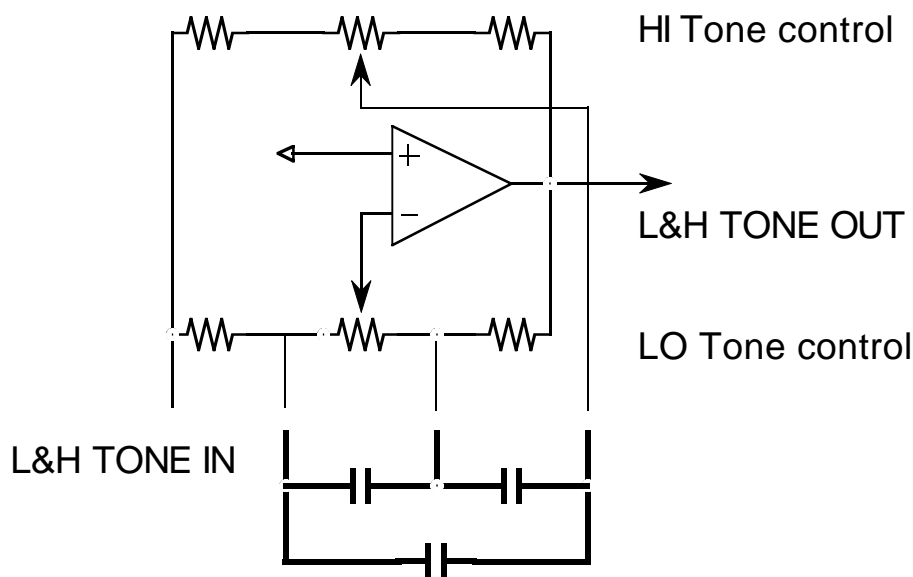

<Frequency Characteristic>

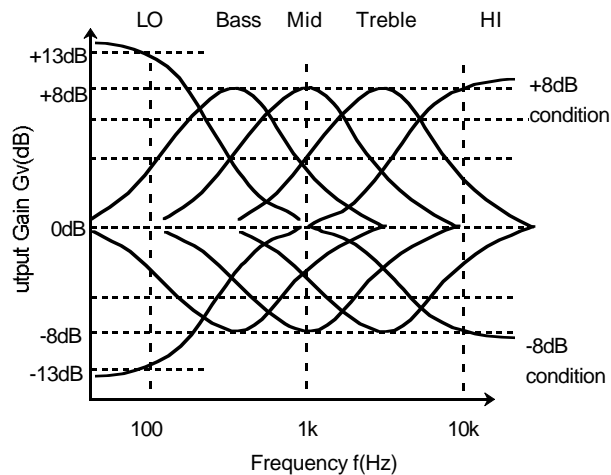

PRELIMINARY
 Notice ; This is not a final specification.
 some parametric limits are subject to change

M615XXFP

Digital controlled Sound Controller

(4) Bass Boost circuit

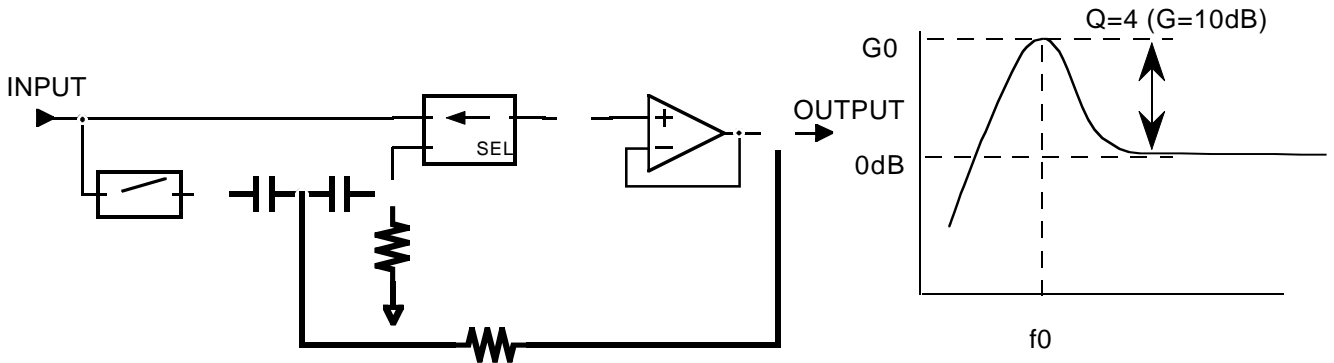

Positive feedback 2 order HPF circuit

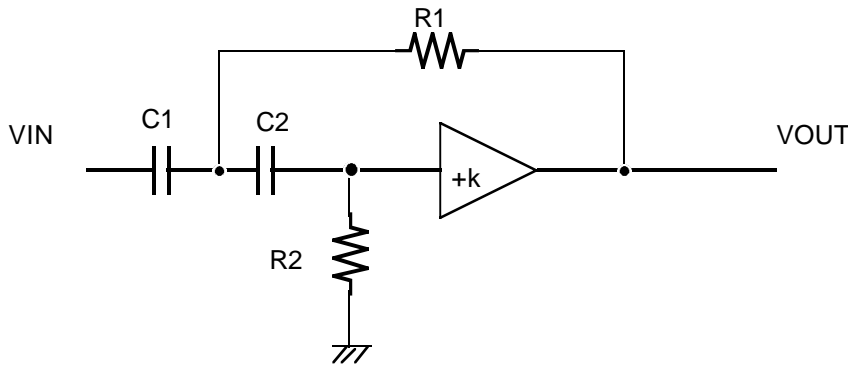

2 order HPF Gain Characteristic (ex.)

Q	g0
1	0 to 1 dB
2	6 dB
4	10 dB
5	13 dB
10	20 dB

$$\frac{V_{OUT}}{V_{IN}} = \frac{Ks^2}{s^2 + s \left[\frac{1}{R2C1} + \frac{1}{R2C2} + (1-K) \frac{1}{R1C1} \right] + \frac{1}{R1R2C1C2}}$$

$$\omega_0^2 = \frac{1}{R1R2C1C2}$$

$$Q = \frac{1}{\sqrt{\frac{R1C1}{R2C2}} + \sqrt{\frac{R1C2}{R2C1}} + (1-K)\sqrt{\frac{R2C2}{R1C1}}}$$

Bass boost consist of positive feedback 2 order HPF circuit
 Method of calculation indicate below.

In this condition

$C1 = C2 = C_f, K = +1$ calculated $R_f = 1/((\omega_0 C_f))$ (1) $R1 = R_f/2Q$ (2) $R2 = 2QR_f$ (3)
--

$F_c = 70\text{Hz}, Q=4$

$\omega_0 = 2\pi \times 70\text{Hz}, Q=4$

In this condition

$C1=C2=C_f=0.1\mu\text{F},$
 from (1), (2), (3)

$R_f=22.7\text{K}\Omega$

$R1 = 2.84\text{K}\Omega$

$R2 = 182\text{K}\Omega$

$R1, R2 = \text{about } 3.0\text{K}\Omega, 200\text{K}\Omega$

PRELIMINARY
 Notice ; This is not a final specification.
 Some parametric limits are subject to change

M615XXFP

Digital controlled Sound Controller

(5) SURROUND Mode

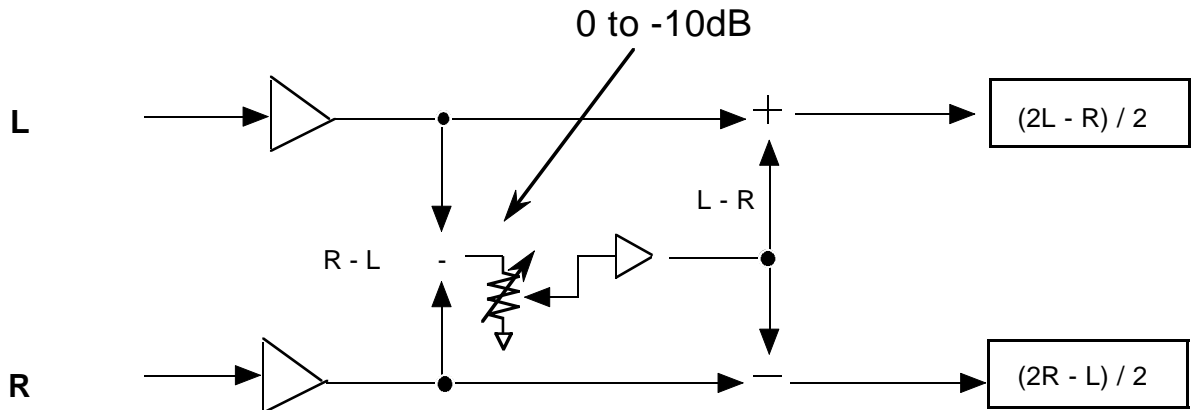

(6) DPL Mode select

8-1 Thru Mode

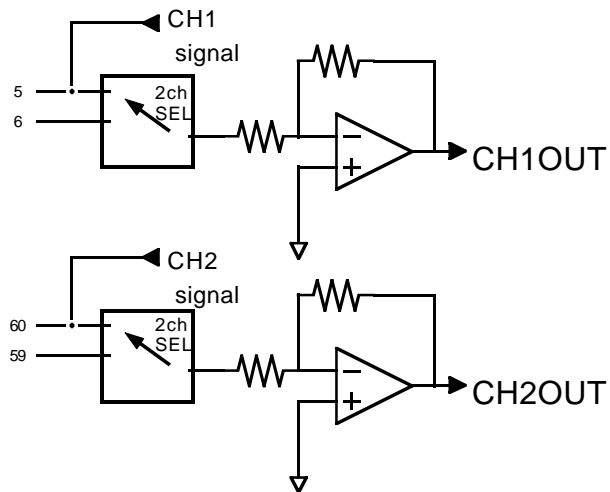

8-2 DPL Mode

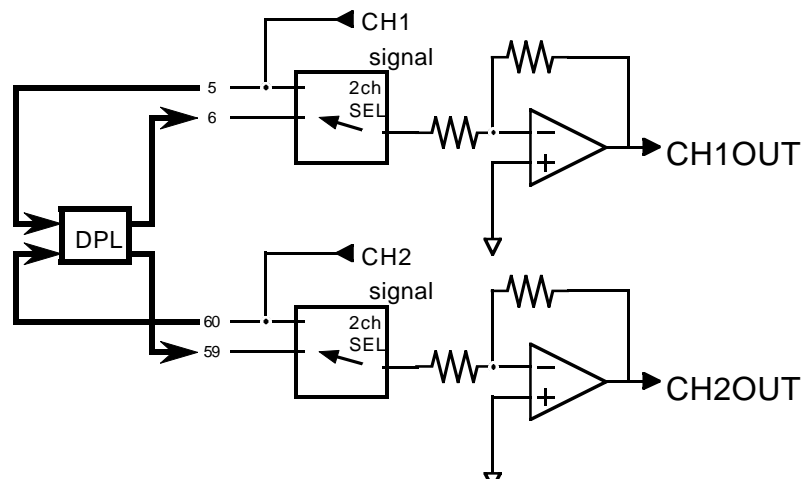

PRELIMINARY
 Notice ; This is not a final specification.
 Some parametric limits are subject to change

M615XFP

Digital controlled Sound Controller

(7)Sound Effect

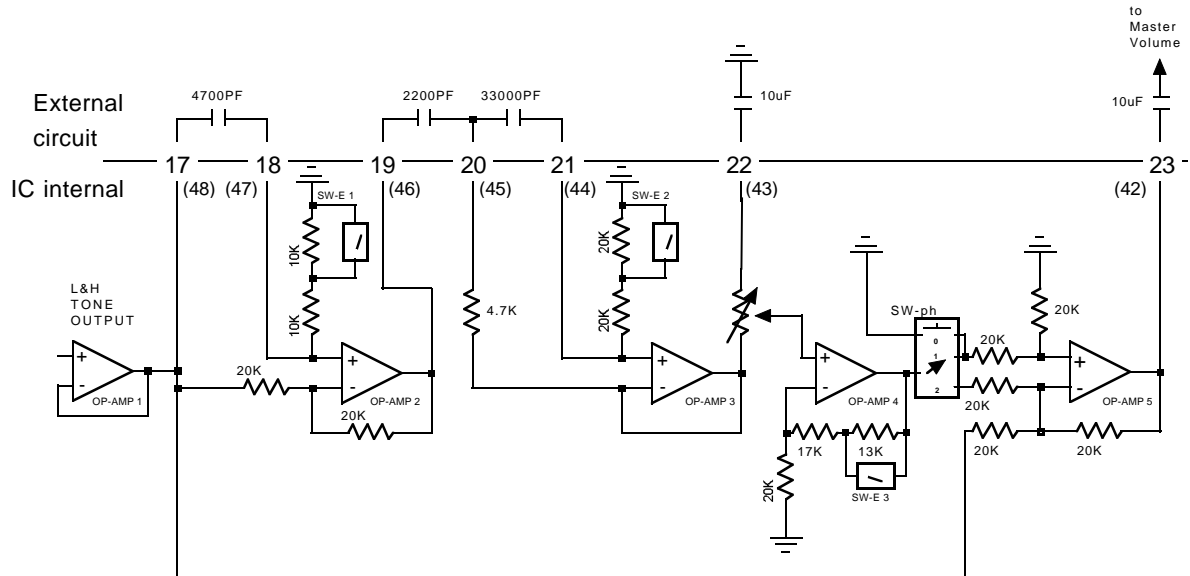

SW-E1,SW-E2,SW-E3,SW-ph

Condition	SW-E1,E2	SW-E3	SW-ph
-phase	ON	OFF	1
+phase	OFF	ON	2
0dB(through)	-	-	0 (1,2:off)

Sound Effect Frequency Characteristic

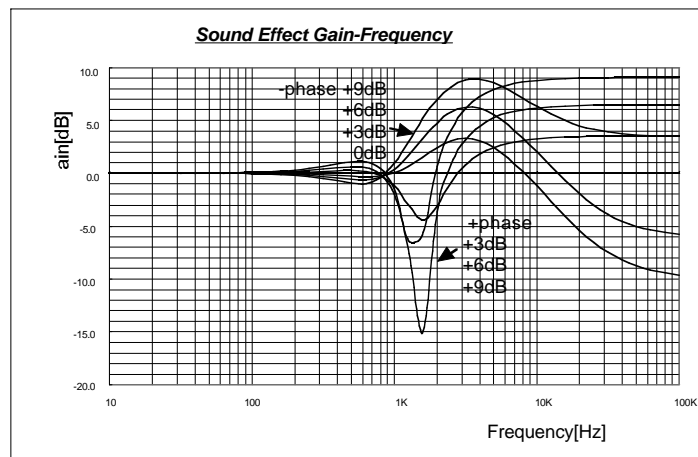

PRELIMINARY
 Notice ; This is not a final specification.
 some parametric limits are subject to change

M615XXFP

Digital controlled Sound Controller

LEVEL DIAGRAM

(1) Stereo, L mono, R mono

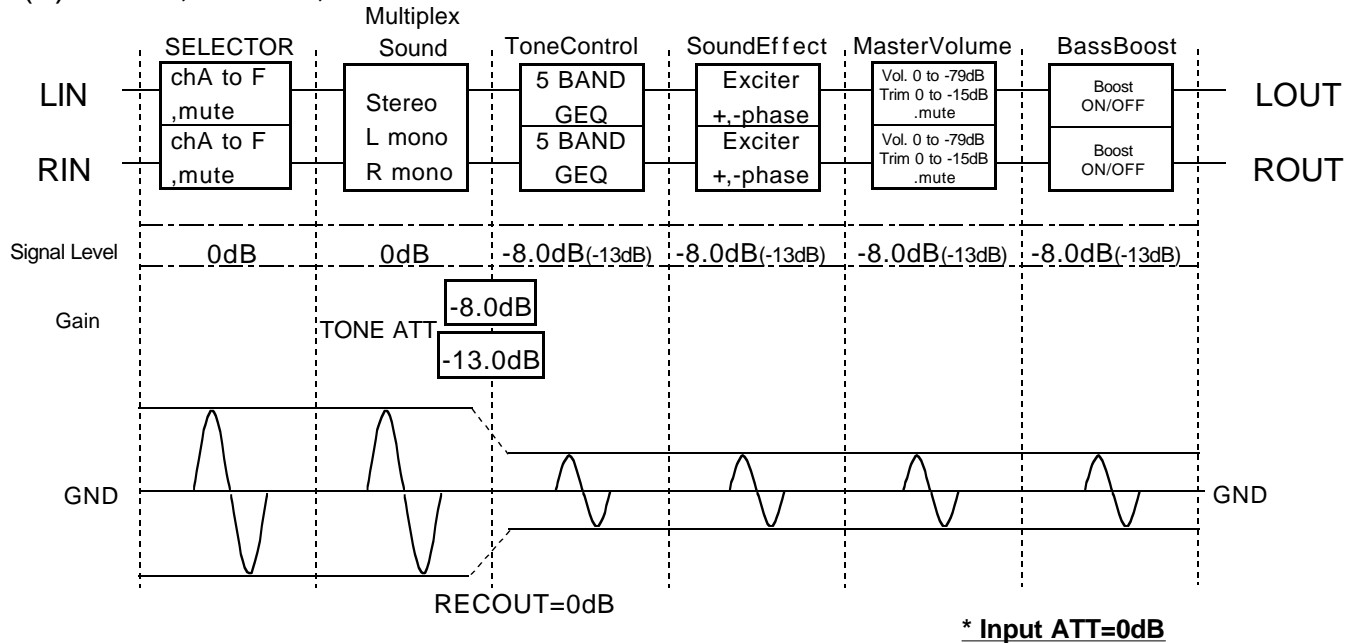

(2) SURROUND

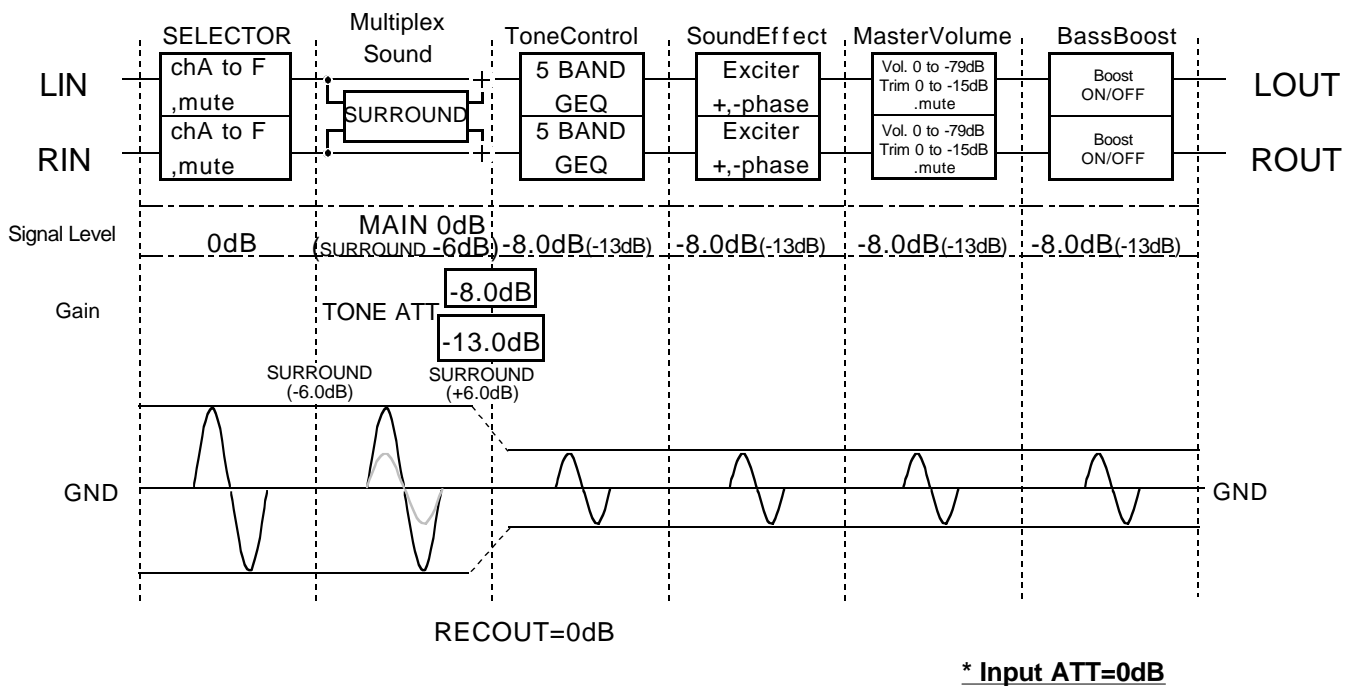

PRELIMINARY
 Notice ; This is not a final specification.
 Some parametric limits are subject to change

M615XFP

Digital controlled Sound Controller

