

MITSUBISHI LSIs
M6MGB/T160S4BVP

16,777,216-BIT (1,048,576 -WORD BY 16-BIT / 2,097,152-WORD BY 8-BIT) CMOS
3.3V-ONLY FLASH MEMORY &
4,194,304-BIT (262,144WORD BY 16-BIT / 524,288-WORD BY 8-BIT) CMOS SRAM
Stacked-MCP (Multi Chip Package)

DESCRIPTION

The MITSUBISHI M6MGB/T160S4BVP is a Stacked Multi Chip Package (S-MCP) that contents 16M-bits flash memory and 4M-bits Static RAM in a 48-pin TSOP (TYPE-I).

16M-bits Flash memory is a 2097152 bytes /1048576 words, 3.3V-only, and high performance non-volatile memory fabricated by CMOS technology for the peripheral circuit and DINOR(DIvided bit-line NOR) architecture for the memory cell.

4M-bits SRAM is a 524288bytes / 262144words unsynchronous SRAM fabricated by silicon-gate CMOS technology.

M6MGB/T160S4BVP is suitable for the application of the mobile-communication-system to reduce both the mount space and weight .

FEATURES

- Access time

Flash Memory	90ns (Max.)
SRAM	85ns (Max.)
- Supply voltage V_{cc}=2.7 ~ 3.6V
- Ambient temperature

W version	T _a =-20 ~ 85°C
-----------	----------------------------
- Package : 48-pin TSOP (Type-I) , 0.4mm lead pitch

APPLICATION

Mobile communication products

PIN CONFIGURATION (TOP VIEW)

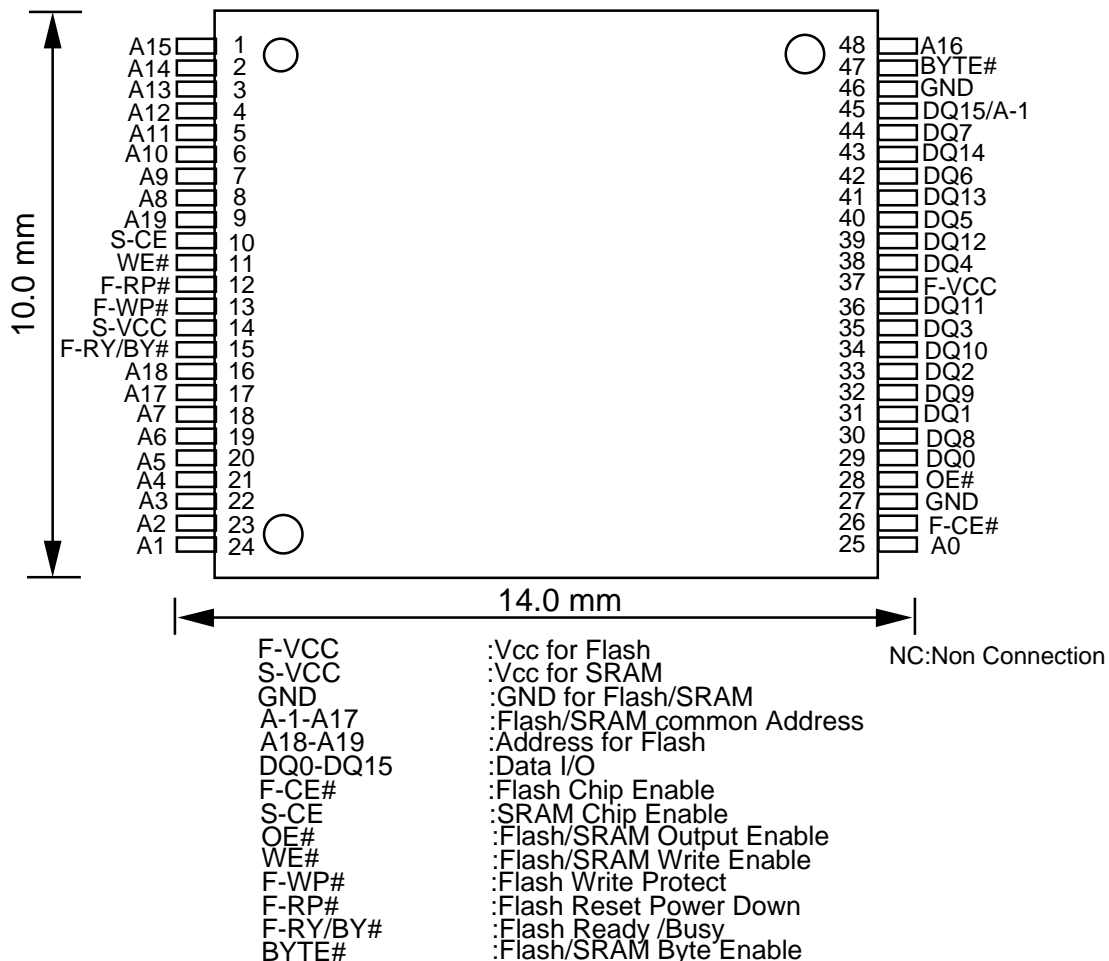

MITSUBISHI LSIs
M6MGB/T160S4BVP

16,777,216-BIT (1,048,576 -WORD BY 16-BIT / 2,097,152-WORD BY 8-BIT) CMOS
 3.3V-ONLY FLASH MEMORY &
 4,194,304-BIT (262,144WORD BY 16-BIT / 524,288-WORD BY 8-BIT) CMOS SRAM
 Stacked-MCP (Multi Chip Package)

BLOCK DIAGRAM

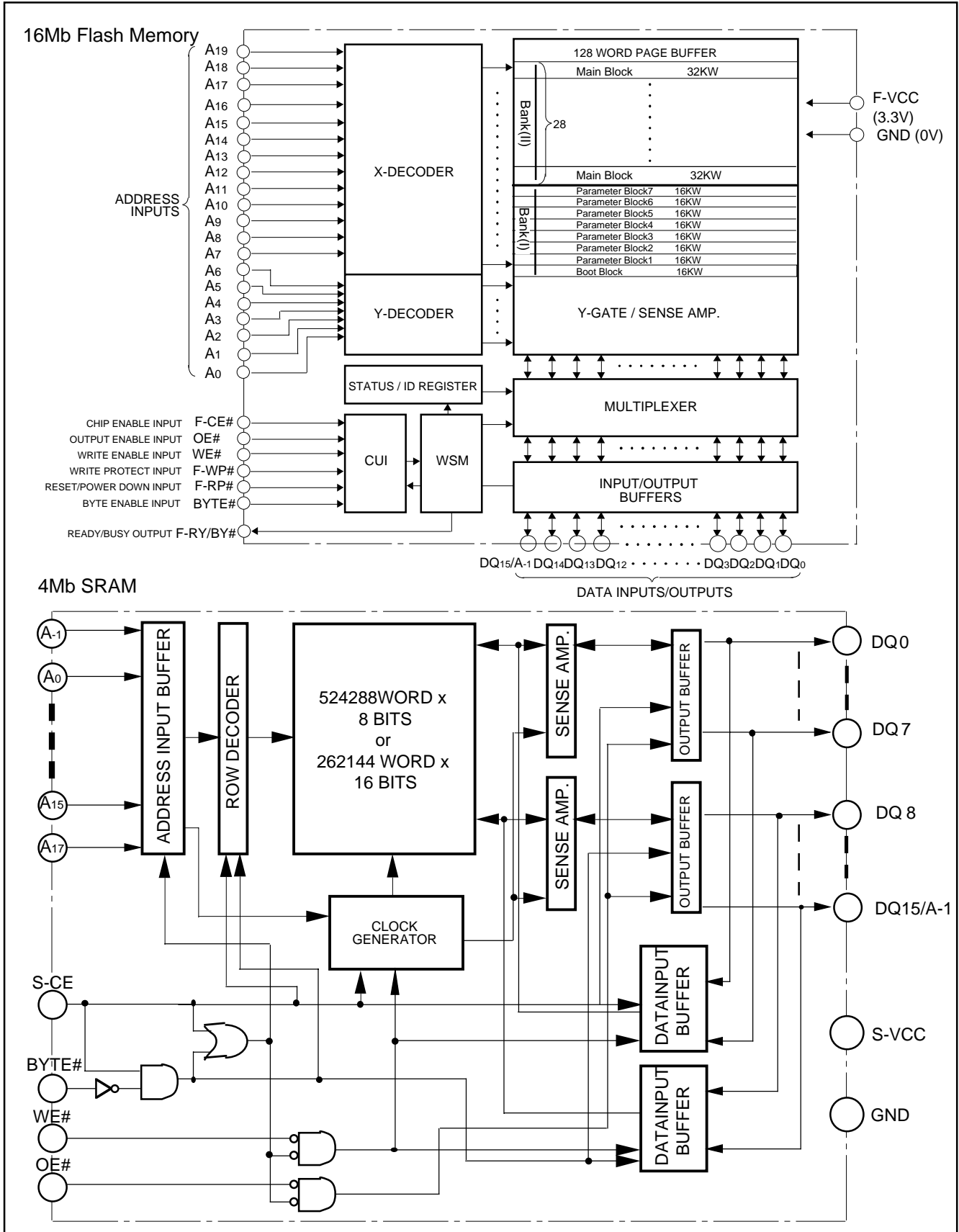

1. Flash Memory

DESCRIPTION

The Flash Memory of M6MGB/T160S4BVP is 3.3V-only high speed 16,777,216-bit CMOS boot block Flash Memories with alternating BGO (Back Ground Operation) feature. The BGO feature of the device allows Program or Erase operations to be performed in one bank while the device simultaneously allows Read operations to be performed on the other bank. This BGO feature is suitable for mobile and personal computing, and communication products. The Flash Memory of M6MGB/T160S4BVP is fabricated by CMOS technology for the peripheral circuits and DINOR(Divided bit line NOR) architecture for the memory cells.

FEATURES

- Organization
 -1048,576 word x 16bit
 -2,097,152 word x 8 bit
- Supply voltage Vcc = 2.7~3.6V
- Access time 90ns(Max.)
- Power Dissipation
 - Read 54 mW (Max. at 5MHz)
 - (After Automatic Power saving) 0.33μW (typ.)
 - Program/Erase144 mW (Max.)
 - Standby 0.33μW (typ.)
 - Deep power down mode 0.33μW (typ.)
- Auto program for Bank(I)
 - Program Time 4ms (typ.)
 - Program Unit
 - (Byte Program)1word/1byte
 - (Page Program) 128word/256byte
- Auto program for Bank(II)
 - Program Time 4ms (typ.)
 - Program Unit 128word/256byte
- Auto Erase
 - Erase time 40 ms (typ.)
 - Erase Unit
 - Bank(I) Boot Block 16Kword/32Kbyte x 1
 - Parameter Block 16Kword/32Kbyte x 7
 - Bank(II) Main Block 32Kword/64Kbyte x 28
- Program/Erase cycles100Kcycles
- Boot Block
 - M6MGB160S4BVP Bottom Boot
 - M6MGT160S4BVP Top Boot
- Other Functions
 - Soft Ware Command Control
 - Selective Block Lock
 - Erase Suspend/Resume
 - Program Suspend/Resume
 - Status Register Read
 - Alternating Back Ground Program/Erase Operation
Between Bank(I) and Bank(II)

FUNCTION

The Flash Memory of M6MGB/T160S4BVP includes on-chip program/erase control circuitry. The Write State Machine (WSM) controls block erase and byte/page program operations. Operational modes are selected by the commands written to the Command User Interface (CUI). The Status Register indicates the status of the WSM and when the WSM successfully completes the desired program or block erase operation.

A Deep Powerdown mode is enabled when the RP# pin is at GND, minimizing power consumption.

Read

The Flash Memory of M6MGB/T160S4BVP has three read modes, which accesses to the memory array, the Device Identifier and the Status Register. The appropriate read command are required to be written to the CUI. Upon initial device powerup or after exit from deep powerdown, the Flash Memory automatically resets to read array mode. In the read array mode, low level input to F-CE# and OE#, high level input to WE# and RP#, and address signals to the address inputs (A19-A-1:Byte Mode, A19-A0:Word Mode) output the data of the addressed location to the data input/output (D7-D0:Byte Mode, D15-D0:Word Mode).

Write

Writes to the CUI enables reading of memory array data, device identifiers and reading and clearing of the Status Register. They also enable block erase and program. The CUI is written by bringing WE# to low level, while F-CE# is at low level and OE# is at high level. Address and data are latched on the earlier rising edge of WE# and F-CE#. Standard micro-processor write timings are used.

Alternating Background Operation (BGO)

The Flash Memory of M6MGB/T160S4BVP allows to read array from one bank while the other bank operates in software command write cycling or the erasing / programming operation in the background. Read array operation with the other bank in BGO is performed by changing the bank address without any additional command. When the bank address points the bank in software command write cycling or the erasing / programming operation, the data is read out from the status register. The access time with BGO is the same as the normal read operation.

Output Disable

When OE# is at VIH, output from the devices is disabled. Data input/output are in a high-impedance(High-Z) state.

Standby

When F-CE# is at VIH, the device is in the standby mode and its power consumption is reduced. Data input/output are in a high-impedance(High-Z) state. If the memory is deselected during block erase or program, the internal control circuits remain active and the device consume normal active power until the operation completes.

Deep Power-Down

When RP# is at VIL, the device is in the deep powerdown mode and its power consumption is substantially low. During read modes, the memory is deselected and the data input/output are in a high-impedance(High-Z) state. After return from powerdown, the CUI is reset to Read Array, and the Status Register is cleared to value 80H.

During block erase or program modes, RP# low will abort either operation. Memory array data of the block being altered become invalid.

Automatic Power-Saving (APS)

The Automatic Power-Saving minimizes the power consumption during read mode. The device automatically turns to this mode when any addresses or F-CE# isn't changed more than 200ns after the last alternation. The power consumption becomes the same as the stand-by mode. While in this mode, the output data is latched and can be read out. New data is read out correctly when addresses are changed.

SOFTWARE COMMAND DEFINITIONS

The device operations are selected by writing specific software command into the Command User Interface.

Read Array Command (FFH)

The device is in Read Array mode on initial device power up and after exit from deep powerdown, or by writing FFH to the Command User Interface. After starting the internal operation the device is set to the read status register mode automatically.

Read Device Identifier Command (90H)

It can normally read device identifier codes when Read Device Identifier Code Command(90H) is written to the command latch. Following the command write, the manufacturer code and the device code can be read from address 0000H and 0001H, respectively.

Read Status Register Command (70H)

The Status Register is read after writing the Read Status Register command of 70H to the Command User Interface. Also, after starting the internal operation the device is set to the Read Status Register mode automatically.

The contents of Status Register are latched on the later falling edge of OE# or F-CE#. So F-CE# or OE# must be toggled every status read.

Clear Status Register Command (50H)

The Erase Status, Program Status and Block Status bits are set to "1"s by the Write State Machine and can only be reset by the Clear Status Register command of 50H. These bits indicates various failure conditions.

Block Erase / Confirm Command (20H/D0H)

Automated block erase is initiated by writing the Block Erase command of 20H followed by the Confirm command of D0H. An address within the block to be erased is required. The WSM executes iterative erase pulse application and erase verify operation.

Program Commands

A)Word/Byte Program (40H)

Word/Byte program is executed by a two-command sequence. The Word/Byte Program Setup command of 40H is written to the Command Interface, followed by a second write specifying the address and data to be written. The WSM controls the program pulse application and verify operation. The Word/Byte Program Command is Valid for only Bank(I).

B)Page Program for Data Blocks (41H)

Page Program for Bank(I) and Bank(II) allows fast programming of 128words/256bytes of data. Writing of 41H initiates the page program operation for the Data area. From 2nd cycle to 257th cycle (Byte Mode)129th cycle (Word Mode), write data must be serially inputted. Address A6-A0,A-1 (Byte Mode) / A6-A0 (Word Mode) have to be incremented from 00H to 7FH/FFH. After completion of data loading, the WSM controls the program pulse application and verify operation.

C)Single Data Load to Page Buffer (74H) / Page Buffer to Flash (0EH/D0H)

Single data load to the page buffer is performed by writing 74H followed by a second write specifying the column address and data. Distinct data up to 256byte/128word can be loaded to the page buffer by this two-command sequence. On the other hand, all of the loaded data to the page buffer is programmed simultaneously by writing Page Buffer to Flash command of 0EH followed by the confirm command of D0H. After completion of programming the data on the page buffer is cleared automatically. This command is valid for only Bank(I) alike Word/Byte Program.

Clear Page Buffer Command (55H)

Loaded data to the page buffer is cleared by writing the Clear Page Buffer command of 55H followed by the Confirm command of D0H. This command is valid for clearing data loaded by Single Data Load to Page Buffer command.

Suspend/Resume Command (B0H/D0H)

Writing the Suspend command of B0H during block erase operation interrupts the block erase operation and allows read out from another block of memory. Writing the Suspend command of B0H during program operation interrupts the program operation and allows read out from another block of memory. The Bank address is required when writing the Suspend/Resume Command. The device continues to output Status Register data when read, after the Suspend command is written to it. Polling the WSM Status and Suspend Status bits will determine when the erase operation or program operation has been suspended. At this point, writing of the Read Array command to the CUI enables reading data from blocks other than that which is suspended. When the Resume command of D0H is written to the CUI, the WSM will continue with the erase or program processes.

DATA PROTECTION

The Flash Memory of M6MGB/T160S4BVP provides selectable block locking of memory blocks. Each block has an associated nonvolatile lock-bit which determines the lock status of the block. In addition, the Flash Memory has a master Write Protect pin (WP#) which prevents any modifications to memory blocks whose lock-bits are set to "0", when WP# is low. When WP# is high, all blocks can be programmed or erased regardless of the state of the lock-bits, and the lock-bits are cleared to "1" by erase. See the BLOCK LOCKING table on P.9 for details.

Power Supply Voltage

When the power supply voltage (F-Vcc) is less than VLKO, Low Vcc Lock-Out voltage, the device is set to the Read-only mode. Regarding DC electrical characteristics of VLKO, see P.10.

A delay time of 2 us is required before any device operation is initiated. The delay time is measured from the time F-Vcc reaches F-Vccmin (2.7V).

During power up, RP#=GND is recommended. Falling in Busy status is not recommended for possibility of damaging the device.

MEMORY ORGANIZATION

The Flash Memory of M6MGB/T16S2BVP has one 32Kbyte boot block, seven 32Kbyte parameter blocks, for Bank(I) and twenty-eight 64Kbyte main blocks for Bank(II). A block is erased independently of other blocks in the array.

MITSUBISHI LSIs
M6MGB/T160S4BVP

16,777,216-BIT (1,048,576 -WORD BY 16-BIT / 2,097,152-WORD BY 8-BIT) CMOS
3.3V-ONLY FLASH MEMORY &
4,194,304-BIT (262,144WORD BY 16-BIT / 524,288-WORD BY 8-BIT) CMOS SRAM
Stacked-MCP (Multi Chip Package)

MEMORY ORGANIZATION

x8 (Byte mode)	x16 (Word mode)		x8 (Byte mode)	x16 (Word mode)	
1F0000H-1FFFFFFH	F8000H-FFFFFFH	32Kword MAIN BLOCK 35	1F8000H-1FFFFFFH	FC000H-FFFFFFH	16Kword BOOT BLOCK 35
1E0000H-1EFFFFFFH	F0000H-F7FFFFH	32Kword MAIN BLOCK 34	1F0000H-1F7FFFFH	F8000H-FBFFFFH	16Kword PARAMETER BLOCK 34
1D0000H-1DFFFFFFH	E8000H-EFFFFFFH	32Kword MAIN BLOCK 33	1E8000H-1EFFFFFFH	F4000H-F7FFFFH	16Kword PARAMETER BLOCK 33
1C0000H-1CFFFFFFH	E0000H-E7FFFFH	32Kword MAIN BLOCK 32	1E0000H-1E7FFFFH	F0000H-F3FFFFH	16Kword PARAMETER BLOCK 32
1B0000H-1BFFFFFFH	D8000H-DFFFFFFH	32Kword MAIN BLOCK 31	1D8000H-1DFFFFFFH	EC000H-EFFFFFFH	16Kword PARAMETER BLOCK 31
1A0000H-1AFFFFFFH	D0000H-D7FFFFH	32Kword MAIN BLOCK 30	1D0000H-1D7FFFFH	E8000H-EBFFFFH	16Kword PARAMETER BLOCK 30
190000H-19FFFFFFH	C8000H-CFFFFFFH	32Kword MAIN BLOCK 29	1C8000H-1CFFFFFFH	E4000H-E7FFFFH	16Kword PARAMETER BLOCK 29
180000H-18FFFFFFH	C0000H-C7FFFFH	32Kword MAIN BLOCK 28	1C0000H-1C7FFFFH	E0000H-E3FFFFH	16Kword PARAMETER BLOCK 28
170000H-17FFFFFFH	B8000H-BFFFFFFH	32Kword MAIN BLOCK 27	1B0000H-1BFFFFFFH	D8000H-DFFFFFFH	32Kword MAIN BLOCK 27
160000H-16FFFFFFH	B0000H-B7FFFFH	32Kword MAIN BLOCK 26	1A0000H-1AFFFFFFH	D0000H-D7FFFFH	32Kword MAIN BLOCK 26
150000H-15FFFFFFH	A8000H-AFFFFFFH	32Kword MAIN BLOCK 25	190000H-19FFFFFFH	C8000H-CFFFFFFH	32Kword MAIN BLOCK 25
140000H-14FFFFFFH	A0000H-A7FFFFH	32Kword MAIN BLOCK 24	180000H-18FFFFFFH	C0000H-C7FFFFH	32Kword MAIN BLOCK 24
130000H-13FFFFFFH	98000H-9FFFFFFH	32Kword MAIN BLOCK 23	170000H-17FFFFFFH	B8000H-BFFFFFFH	32Kword MAIN BLOCK 23
120000H-12FFFFFFH	90000H-97FFFFH	32Kword MAIN BLOCK 22	160000H-16FFFFFFH	B0000H-B7FFFFH	32Kword MAIN BLOCK 22
110000H-11FFFFFFH	88000H-8FFFFFFH	32Kword MAIN BLOCK 21	150000H-15FFFFFFH	A8000H-AFFFFFFH	32Kword MAIN BLOCK 21
100000H-10FFFFFFH	80000H-87FFFFH	32Kword MAIN BLOCK 20	140000H-14FFFFFFH	A0000H-A7FFFFH	32Kword MAIN BLOCK 20
F0000H-FFFFFFH	78000H-7FFFFFFH	32Kword MAIN BLOCK 19	130000H-13FFFFFFH	98000H-9FFFFFFH	32Kword MAIN BLOCK 19
E0000H-EFFFFFFH	70000H-77FFFFH	32Kword MAIN BLOCK 18	120000H-12FFFFFFH	90000H-97FFFFH	32Kword MAIN BLOCK 18
D0000H-DFFFFFFH	68000H-6FFFFFFH	32Kword MAIN BLOCK 17	110000H-11FFFFFFH	88000H-8FFFFFFH	32Kword MAIN BLOCK 17
C0000H-CFFFFFFH	60000H-67FFFFH	32Kword MAIN BLOCK 16	100000H-10FFFFFFH	80000H-87FFFFH	32Kword MAIN BLOCK 16
B0000H-BFFFFFFH	58000H-5FFFFFFH	32Kword MAIN BLOCK 15	F0000H-FFFFFFH	78000H-7FFFFFFH	32Kword MAIN BLOCK 15
A0000H-AFFFFFFH	50000H-57FFFFH	32Kword MAIN BLOCK 14	E0000H-EFFFFFFH	70000H-77FFFFH	32Kword MAIN BLOCK 14
90000H-9FFFFFFH	48000H-4FFFFFFH	32Kword MAIN BLOCK 13	D0000H-DFFFFFFH	68000H-6FFFFFFH	32Kword MAIN BLOCK 13
80000H-8FFFFFFH	40000H-47FFFFH	32Kword MAIN BLOCK 12	C0000H-CFFFFFFH	60000H-67FFFFH	32Kword MAIN BLOCK 12
70000H-7FFFFFFH	38000H-3FFFFFFH	32Kword MAIN BLOCK 11	B0000H-BFFFFFFH	58000H-5FFFFFFH	32Kword MAIN BLOCK 11
60000H-6FFFFFFH	30000H-37FFFFH	32Kword MAIN BLOCK 10	A0000H-AFFFFFFH	50000H-57FFFFH	32Kword MAIN BLOCK 10
50000H-5FFFFFFH	28000H-2FFFFFFH	32Kword MAIN BLOCK 9	90000H-9FFFFFFH	48000H-4FFFFFFH	32Kword MAIN BLOCK 9
40000H-4FFFFFFH	20000H-27FFFFH	32Kword MAIN BLOCK 8	80000H-8FFFFFFH	40000H-47FFFFH	32Kword MAIN BLOCK 8
38000H-3FFFFFFH	1C000H-1FFFFH	16Kword PARAMETER BLOCK 7	70000H-7FFFFFFH	38000H-3FFFFFFH	32Kword MAIN BLOCK 7
30000H-37FFFFH	18000H-1BFFFFH	16Kword PARAMETER BLOCK 6	60000H-6FFFFFFH	30000H-37FFFFH	32Kword MAIN BLOCK 6
28000H-2FFFFFFH	14000H-17FFFFH	16Kword PARAMETER BLOCK 5	50000H-5FFFFFFH	28000H-2FFFFFFH	32Kword MAIN BLOCK 5
20000H-27FFFFH	10000H-13FFFFH	16Kword PARAMETER BLOCK 4	40000H-4FFFFFFH	20000H-27FFFFH	32Kword MAIN BLOCK 4
18000H-1FFFFFFH	0C000H-0FFFFFFH	16Kword PARAMETER BLOCK 3	30000H-3FFFFFFH	18000H-1FFFFFFH	32Kword MAIN BLOCK 3
10000H-17FFFFH	08000H-0BFFFFH	16Kword PARAMETER BLOCK 2	20000H-2FFFFFFH	10000H-17FFFFH	32Kword MAIN BLOCK 2
08000H-0FFFFFFH	04000H-07FFFFH	16Kword PARAMETER BLOCK 1	10000H-1FFFFFFH	08000H-0FFFFFFH	32Kword MAIN BLOCK 1
00000H-07FFFFH	00000H-03FFFFH	16Kword BOOT BLOCK 0	00000H-0FFFFFFH	00000H-07FFFFH	32Kword MAIN BLOCK 0

Flash Memory of M6MGB160S4BVP
Memory Map

Flash Memory of M6MGT160S4BVP
Memory Map

MITSUBISHI LSIs
M6MGB/T160S4BVP

16,777,216-BIT (1,048,576 -WORD BY 16-BIT / 2,097,152-WORD BY 8-BIT) CMOS
3.3V-ONLY FLASH MEMORY &
4,194,304-BIT (262,144WORD BY 16-BIT / 524,288-WORD BY 8-BIT) CMOS SRAM
Stacked-MCP (Multi Chip Package)

BUS OPERATIONS

Bus Operations for Word-Wide Mode

Mode \ Pins		F-CE#	OE#	WE#	RP#	DQ0-15	RY/BY#
Read	Array	V _{IL}	V _{IL}	V _{IH}	V _{IH}	Data out	VOH (Hi-Z)
	Status Register	V _{IL}	V _{IL}	V _{IH}	V _{IH}	Status Register Data	X ¹⁾
	Lock Bit Status	V _{IL}	V _{IL}	V _{IH}	V _{IH}	Lock Bit Data (DQ6)	X
	Identifier Code	V _{IL}	V _{IL}	V _{IH}	V _{IH}	Identifier Code	VOH (Hi-Z)
Output disable		V _{IL}	V _{IH}	V _{IH}	V _{IH}	Hi-Z	X
Stand by		V _{IH}	X ²⁾	X	V _{IH}	Hi-Z	X
Write	Program	V _{IL}	V _{IH}	V _{IL}	V _{IH}	Command/Data in	X
	Erase	V _{IL}	V _{IH}	V _{IL}	V _{IH}	Command	X
	Others	V _{IL}	V _{IH}	V _{IL}	V _{IH}	Command	X
Deep Power Down		X	X	X	V _{IL}	Hi-Z	VOH (Hi-Z)

Bus Operations for Byte-Wide Mode

Mode \ Pins		F-CE#	OE#	WE#	RP#	DQ0-7	RY/BY#
Read	Array	V _{IL}	V _{IL}	V _{IH}	V _{IH}	Data out	VOH (Hi-Z)
	Status Register	V _{IL}	V _{IL}	V _{IH}	V _{IH}	Status Register Data	X ¹⁾
	Lock Bit Status	V _{IL}	V _{IL}	V _{IH}	V _{IH}	Lock Bit Data (DQ6)	X
	Identifier Code	V _{IL}	V _{IL}	V _{IH}	V _{IH}	Identifier Code	VOH (Hi-Z)
Output disable		V _{IL}	V _{IH}	V _{IH}	V _{IH}	Hi-Z	X
Stand by		V _{IH}	X ²⁾	X	V _{IH}	Hi-Z	X
Write	Program	V _{IL}	V _{IH}	V _{IL}	V _{IH}	Command/Data in	X
	Erase	V _{IL}	V _{IH}	V _{IL}	V _{IH}	Command	X
	Others	V _{IL}	V _{IH}	V _{IL}	V _{IH}	Command	X
Deep Power Down		X	X	X	V _{IL}	Hi-Z	VOH (Hi-Z)

1) X at RY/BY# is VOL or VOH(Hi-Z).

*The RY/BY# is an open drain output pin and indicates status of the internal WSM. When low, it indicates that the WSM is Busy performing an operation. A pull-up resistor of 10K-100K Ohms is required to allow the RY/BY# signal to transition high indicating a Ready WSM condition.

2) X can be V_{IH} or V_{IL} for control pins.

MITSUBISHI LSIs
M6MGB/T160S4BVP

16,777,216-BIT (1,048,576 -WORD BY 16-BIT / 2,097,152-WORD BY 8-BIT) CMOS
3.3V-ONLY FLASH MEMORY &
4,194,304-BIT (262,144WORD BY 16-BIT / 524,288-WORD BY 8-BIT) CMOS SRAM
Stacked-MCP (Multi Chip Package)

SOFTWARE COMMAND DEFINITION

Command List

Command	1st bus cycle			2nd bus cycle			3rd ~257th bus cycles (Byte Mode) 3rd ~129th bus cycles (Word Mode)		
	Mode	Address	Data (DQ7-0) ¹⁾ (DQ15-0)	Mode	Address	Data (DQ7-0) (DQ15-0)	Mode	Address	Data (DQ7-0) (DQ15-0)
Read Array	Write	X	FFH						
Device Identifier	Write	X	90H	Read	IA ²⁾	ID ²⁾			
Read Status Register	Write	Bank ³⁾	70H	Read	Bank	SRD ⁴⁾			
Clear Status Register	Write	X	50H						
Clear Page Buffer	Write	X	55H	Write	X	D0H ¹⁾			
Byte/Word Program ⁵⁾	Write	Bank(I) ⁵⁾	40H	Write	WA ⁶⁾	WD ⁶⁾			
Page Program ⁷⁾	Write	Bank	41H	Write	WA0 ⁷⁾	WD0 ⁷⁾	Write	WAn ⁷⁾	WDn ⁷⁾
Single Data Load to Page Buffer ⁵⁾	Write	Bank(I) ⁵⁾	74H	Write	WA	WD			
Page Buffer to Flash ⁵⁾	Write	Bank(I) ⁵⁾	0EH	Write	WA ⁸⁾	D0H ¹⁾			
Block Erase / Confirm	Write	Bank	20H	Write	BA ⁹⁾	D0H ¹⁾			
Suspend	Write	Bank	B0H						
Resume	Write	Bank	D0H						
Read Lock Bit Status	Write	X	71H	Read	BA	DQ6 ¹⁰⁾			
Lock Bit Program / Confirm	Write	Bank	77H	Write	BA	D0H ¹⁾			
Erase All Unlocked Blocks	Write	X	A7H	Write	X	D0H ¹⁾			

1) In the word-wide version(Byte#=H), upper byte data (DQ8-DQ15) is ignored.

2) IA=ID Code Address : A0=VIL (Manufacturer's Code) : A0=VIH (Device Code), ID=ID Code

3) Bank = Bank Address (Bank(I) or Bank(II)) : A19-A17.

4) SRD = Status Register Data

5) Byte/Word Program, Single Data Load and Page Buffer to Flash Command is valid for only Bank(I).

6) WA = Write Address, WD = Write Data

7) WA0,WAn=Write Address, WD0,WDn=Write Data.

Byte Mode : Write Address and Write Data must be provided sequentially from 00H to FFH for A6-A0,A-1. Page size is 256Byte (256byte x 8bit), and also A19-A7(Block Address, Page Address) must be valid.

Word Mode : Write Address and Write Data must be provided sequentially from 00H to 7FH for A6-A0. Page size is 128word (128word x 16bit), and also A19-A7(Block Address, Page Address) must be valid.

8) WA = Write Address : Upper page address, A19-A7(Block Address, Page Address) must be valid.

9) BA = Block Address : BA = Block Address : A19-A14(Bank1) A19-A15(Bank2)

10) DQ6 provides Block Lock Status, DQ6 = 1 : Block Unlock, DQ6 = 0 : Block Locked.

MITSUBISHI LSIs
M6MGB/T160S4BVP

16,777,216-BIT (1,048,576 -WORD BY 16-BIT / 2,097,152-WORD BY 8-BIT) CMOS
3.3V-ONLY FLASH MEMORY &
4,194,304-BIT (262,144WORD BY 16-BIT / 524,288-WORD BY 8-BIT) CMOS SRAM
Stacked-MCP (Multi Chip Package)

BLOCK LOCKING

RP#	WP#	Lock Bit (Internally)	Write Protection Provided				Note
			BANK(I)		BANK(II)	Lock Bit	
			Boot	Parameter	Data		
V _{IL}	X	X	Locked	Locked	Locked	Locked	Deep Power Down Mode
V _{IH}	V _{IL}	0	Locked	Locked	Locked	Locked	
		1	Locked	Unlocked	Unlocked	Locked	
	V _{IH}	X	Unlocked	Unlocked	Unlocked	Unlocked	All Blocks Unlocked

- 1) DQ6 provides Lock Status of each block after writing the Read Lock Status command (71H).
F-WP# pins must not be switched during performing Erase / Write operations or WSM Busy (WSMS = 0).
2) Erase/Write command for locked blocks is aborted. At this time read mode is not array read mode but status read mode and 00B0H is read. Please issue Clear Status Register command plus Read Array command to change the mode from status read mode to array read mode.

STATUS REGISTER

Symbol	Status	Definition	
		"1"	"0"
SR.7 (DQ7)	Write State Machine Status	Ready	Busy
SR.6 (DQ6)	Suspend Status	Suspended	Operation in Progress / Completed
SR.5 (DQ5)	Erase Status	Error	Successful
SR.4 (DQ4)	Program Status	Error	Successful
SR.3 (DQ3)	Block Status after Program	Error	Successful
SR.2 (DQ2)	<i>Reserved</i>	-	-
SR.1 (DQ1)	<i>Reserved</i>	-	-
SR.0 (DQ0)	<i>Reserved</i>	-	-

*The F-RY/BY# is an open drain output pin and indicates status of the internal WSM. When low, it indicates that the WSM is Busy performing an operation. A pull-up resistor of 10K-100K Ohms is required to allow the F-RY/BY# signal to transition high indicating a Ready WSM condition.
*DQ3 indicates the block status after the page programming, byte/word programming and page buffer to flash. When DQ3 is "1", the page has the over-programmed cell. If over-program occurs, the device is block fail. However if DQ3 is "1", please try the block erase to the block. The block may revive.

MITSUBISHI LSIs
M6MGB/T160S4BVP

16,777,216-BIT (1,048,576 -WORD BY 16-BIT / 2,097,152-WORD BY 8-BIT) CMOS
3.3V-ONLY FLASH MEMORY &
4,194,304-BIT (262,144WORD BY 16-BIT / 524,288-WORD BY 8-BIT) CMOS SRAM
Stacked-MCP (Multi Chip Package)

DEVICE IDENTIFIER CODE

Code \ Pins	A ₀	DQ ₇	DQ ₆	DQ ₅	DQ ₄	DQ ₃	DQ ₂	DQ ₁	DQ ₀	Hex. Data
Manufacturer Code	V _{IL}	0	0	0	1	1	1	0	0	1CH
Device Code (-T160S4BVP)	V _{IH}	1	0	1	0	0	0	0	0	A0H
Device Code (-B160S4BVP)	V _{IH}	1	0	1	0	0	0	0	1	A1H

In the word-wide mode, the upper data(D₁₅₋₈) is "0".

ABSOLUTE MAXIMUM RATINGS

Symbol	Parameter	Conditions	Min	Max	Unit
F-V _{cc}	Flash V _{cc} voltage	With respect to Ground	-0.2	4.6	V
V _{I1}	All input or output voltage ¹⁾		-0.6	4.6	V
T _a	Ambient temperature		-20	85	°C
T _{bs}	Temperature under bias		-50	95	°C
T _{stg}	Storage temperature		-65	125	°C
I _{OUT}	Output short circuit current			100	mA

¹⁾ Minimum DC voltage is -0.5V on input/output pins. During transitions, this level may undershoot to -2.0V for periods <20ns. Maximum DC voltage on input/output pins is F-V_{cc}+0.5V which, during transitions, may overshoot to F-V_{cc}+1.5V for periods <20ns.

CAPACITANCE

Symbol	Parameter	Test conditions	Limits			Unit
			Min	Typ	Max	
C _{IN}	Input capacitance (Address, Control Pins)	T _a = 25°C, f = 1MHz, V _{in} = V _{out} = 0V			8	pF
C _{OUT}	Output capacitance				12	pF

Note: The value of common pins to Flash Memory is the sum of Flash Memory and SRAM.

DC ELECTRICAL CHARACTERISTICS (T_a = -20~ 85°C, F-V_{cc} = 2.7V ~ 3.6V, unless otherwise noted)

Symbol	Parameter	Test conditions	Limits			Unit
			Min	Typ ¹⁾	Max	
I _{LI}	Input leakage current	0V ≤ V _{IN} ≤ F-V _{CC}			±2.0	μA
I _{LO}	Output leakage current	0V ≤ V _{OUT} ≤ F-V _{CC}			±11	μA
ISB1	F-V _{cc} standby current	F-V _{CC} = 3.6V, V _{IN} =V _{IL} /V _{IH} , F-CE# = F-RP# = F-WP# = V _{IH}		50	200	μA
ISB2		F-V _{CC} = 3.6V, V _{IN} =GND or F-V _{CC} , F-CE# = F-RP# = F-WP# = F-V _{CC} ±0.3V		0.1	5	μA
ISB3	F-V _{cc} deep powerdown current	F-V _{CC} = 3.6V, V _{IN} =V _{IL} /V _{IH} , F-RP# = V _{IL}		5	15	μA
ISB4		F-V _{CC} = 3.6V, V _{IN} =GND or V _{CC} , F-RP# = GND±0.3V		0.1	5	μA
I _{CC1}	F-V _{cc} read current for Word or Byte	F-V _{CC} = 3.6V, V _{IN} =V _{IL} /V _{IH} , F-CE# = V _{IL} , 5MHz		8	15	mA
		F-RP# = OE# = V _{IH} , I _{OUT} = 0mA, 1MHz		2	4	
I _{CC2}	F-V _{cc} Write current for Word or Byte	F-V _{CC} = 3.6V, V _{IN} =V _{IL} /V _{IH} , F-CE# = WE# = V _{IL} , F-RP# = OE# = V _{IH}			15	mA
I _{CC3}	F-V _{cc} program current	F-V _{CC} = 3.6V, V _{IN} =V _{IL} /V _{IH} , F-CE# = F-RP# = F-WP# = V _{IH}			35	mA
I _{CC4}	F-V _{cc} erase current	F-V _{CC} = 3.6V, V _{IN} =V _{IL} /V _{IH} , F-CE# = F-RP# = F-WP# = V _{IH}			35	mA
I _{CC5}	F-V _{cc} suspend current	F-V _{CC} = 3.6V, V _{IN} =V _{IL} /V _{IH} , F-CE# = F-RP# = F-WP# = V _{IH}			200	μA
V _{IL}	Input low voltage		-0.5		0.8	V
V _{IH}	Input high voltage		2.0		F-V _{cc} +0.5	V
V _{OL}	Output low voltage	I _{OL} = 4.0mA			0.45	V
V _{OH1}	Output high voltage	I _{OH} = -2.0mA	0.85(F-V _{cc})			V
V _{OH2}		I _{OH} = -100μA	F-V _{cc} -0.4			V
V _{LKO}	Low V _{cc} Lock-Out voltage ²⁾		1.5		2.2	V

All currents are in RMS unless otherwise noted.

¹⁾ Typical values at F-V_{cc}=3.3V, T_a=25°C

²⁾ To protect against initiation of write cycle during V_{cc} power-up/ down, a write cycle is locked out for V_{cc} less than V_{LKO}.

If V_{cc} is less than V_{LKO}, Write State Machine is reset to read mode. When the Write State Machine is in Busy state, if V_{cc} is less than V_{LKO}, the alteration of memory contents may occur.

MITSUBISHI LSIs
M6MGB/T160S4BVP

16,777,216-BIT (1,048,576 -WORD BY 16-BIT / 2,097,152-WORD BY 8-BIT) CMOS
3.3V-ONLY FLASH MEMORY &
4,194,304-BIT (262,144WORD BY 16-BIT / 524,288-WORD BY 8-BIT) CMOS SRAM
Stacked-MCP (Multi Chip Package)

AC ELECTRICAL CHARACTERISTICS (Ta = -20 ~85°C)

Read-Only Mode

Symbol		Parameter	Limits			Unit
			Speed Item: -90			
		F-Vcc=2.7~3.6V				
		Min	Typ	Max		
tRC	tAVAV	Read cycle time	90			ns
ta (AD)	tAVQV	Address access time			90	ns
ta (CE)	tELQV	Chip enable access time			90	ns
ta (OE)	tGLQV	Output enable access time			30	ns
tCLZ	tELQX	Chip enable to output in low-Z	0			ns
tDF(CE)	tEHQZ	Chip enable high to output in high Z			25	ns
tOLZ	tGLQX	Output enable to output in low-Z	0			ns
tDF(OE)	tGHQZ	Output enable high to output in high Z			25	ns
tPHZ	tPLQZ	F-RP# low to output high-Z			150	ns
ta(BYTE)	tFL/HQV	BYTE# access time			90	ns
tBHZ	tFLQZ	BYTE# low to output high-Z			25	ns
tOH	tOH	Output hold from F-CE#, OE#, addresses	0			ns
tBCD	tELFL/H	F-CE# low to BYTE# high or low			5	ns
tBAD	tAVFL/H	Address to BYTE# high or low			5	ns
tOEH	tWHGL	OE# hold from WE# high	10			ns
tPS	tPHL	F-RP# recovery to F-CE# low	150			ns

Timing measurements are made under AC waveforms for read operations.

AC ELECTRICAL CHARACTERISTICS (Ta = -20 ~85°C)

Write Mode (WE# control)

Symbol		Parameter	Limits			Unit
			Speed Item: -90			
		F-Vcc=2.7~3.6V				
		Min	Typ	Max		
tWC	tAVAV	Write cycle time	90			ns
tAS	tAVWH	Address set-up time	50			ns
tAH	tWHAX	Address hold time	0			ns
tDS	tDVWH	Data set-up time	50			ns
tDH	tWHDX	Data hold time	0			ns
tOEH	tWHGL	OE# hold from WE# high	10			ns
tRE	-	Latency between Read and Write FFH or 71H	30			ns
tCS	tELWL	Chip enable set-up time	0			ns
tCH	tWHEH	Chip enable hold time	0			ns
tWP	tWLWH	Write pulse width	60			ns
tWPH	tWHWL	Write pulse width high	30			ns
tBS	tFL/HWH	Byte enable high or low set-up time	50			ns
tBH	tWHFL/H	Byte enable high or low hold time	90			ns
tGHWL	tGHWL	OE# hold to WE# Low	0			ns
tBLS	tPHHWH	Block Lock set-up to write enable high	90			ns
tBLH	tQVPH	Block Lockhold from valid SRD	0			ns
tDAP	tWHRH1	Duration of auto-program operation		4	80	ms
tDAE	tWHRH2	Duration of auto-block erase operation		40	600	ms
tWHRL	tWHRL	WE# high to RY/BY# low			90	ns
tPS	tPHWL	F-RP# high recovery to write enable low	150			ns

Read timing parameters during command write operations mode are the same as during read-only operations mode.
Typical values at F-Vcc=3.3V, Ta=25°C

MITSUBISHI LSIs
M6MGB/T160S4BVP

16,777,216-BIT (1,048,576 -WORD BY 16-BIT / 2,097,152-WORD BY 8-BIT) CMOS
3.3V-ONLY FLASH MEMORY &
4,194,304-BIT (262,144WORD BY 16-BIT / 524,288-WORD BY 8-BIT) CMOS SRAM
Stacked-MCP (Multi Chip Package)

AC ELECTRICAL CHARACTERISTICS (Ta = -20 ~ 85°C)

Write Mode (CE# control)

Symbol	Parameter	Limits			Unit	
		Speed Item: -90				
		F-Vcc=2.7~3.6V				
		Min	Typ	Max		
tWC	tAVAV	Write cycle time	90			ns
tAS	tAVWH	Address set-up time	50			ns
tAH	tEHAX	Address hold time	0			ns
tDS	tDVWH	Data set-up time	50			ns
tDH	tEHDX	Data hold time	0			ns
tOE#	tEHGL	OE# hold from F-CE# high	10			ns
tRE	-	Latency between Read and Write FFH or 71H	30			ns
tWS	tWLEL	Write enable set-up time	0			ns
tWH	tEHWL	Write enable hold time	0			ns
tCEP	tELEH	F-CE# pulse width	60			ns
tCEPH	tEHEL	F-CE# pulse width high	30			ns
tBS	tFL/HWH	Byte enable high or low set-up time	50			ns
tBH	tWHFL/H	Byte enable high or low hold time	90			ns
tGHEL	tGHEL	OE# hold to F-CE# Low	90			ns
tBLS	tPHHEH	Block Lock set-up to write enable high	90			ns
tBLH	tQVPH	Block Lockhold from valid SRD	0			ns
tDAP	tEHRH1	Duration of auto-program operation		4	80	ms
tDAE	tEHRH2	Duration of auto-block erase operation		40	600	ms
tEHL	tEHL	F-CE# high to RY/BY# low			90	ns
tPS	tPHWL	F-RP# high recovery to write enable low	150			ns

Read timing parameters during command write operation mode are the same as during read-only operation mode.
Typical values at F-Vcc=3.3V, Ta=25°C

Erase and Program Performance

Parameter	Min	Typ	Max	Unit
Block Erase Time		40	600	ms
Main Block Write Time (Page Mode)		1.0	1.8	sec
Page Write Time		4	80	ms

Program Suspend Latency / Erase Suspend Time

Parameter	Min	Typ	Max	Unit
Program Suspend Latency			15	μs
Erase Suspend Time			15	μs

Please see page 19.

Vcc Power Up / Down Timing

Symbol	Parameter	Min	Typ	Max	Unit
tvCS	RP# =VIH set-up time from Vccmin	2			μs

Please see page 12.

During power up/down, by the noise pulses on control pins, the device has possibility of accidental erasure or programming.
The device must be protected against initiation of write cycle for memory contents during power up/down.
The delay time of min.2μsec is always required before read operation or write operation is initiated from the time F-Vcc reaches F-Vccmin during power up/down.
By holding F-RP# VIL, the contents of memory is protected during F-Vcc power up/down.
During power up, F-RP# must be held VIL for min.2μs from the time F-Vcc reaches F-Vccmin.
During power down, F-RP# must be held VIL until Vcc reaches GND.
F-RP# doesn't have latch mode ,therefore F-RP# must be held VIH during read operation or erase/program operation.

MITSUBISHI LSIs
M6MGB/T160S4BVP

16,777,216-BIT (1,048,576 -WORD BY 16-BIT / 2,097,152-WORD BY 8-BIT) CMOS
 3.3V-ONLY FLASH MEMORY &
 4,194,304-BIT (262,144WORD BY 16-BIT / 524,288-WORD BY 8-BIT) CMOS SRAM
 Stacked-MCP (Multi Chip Package)

Vcc POWER UP / DOWN TIMING

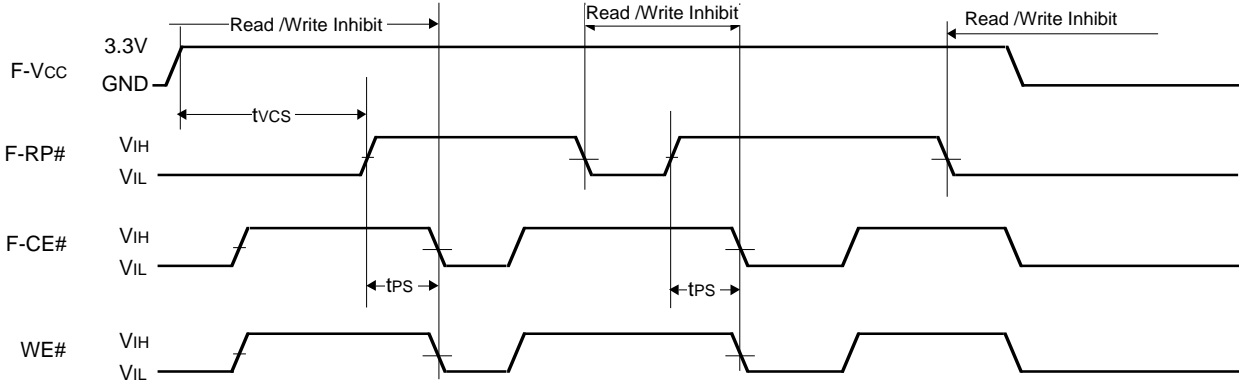

AC WAVEFORMS FOR READ OPERATION AND TEST CONDITIONS

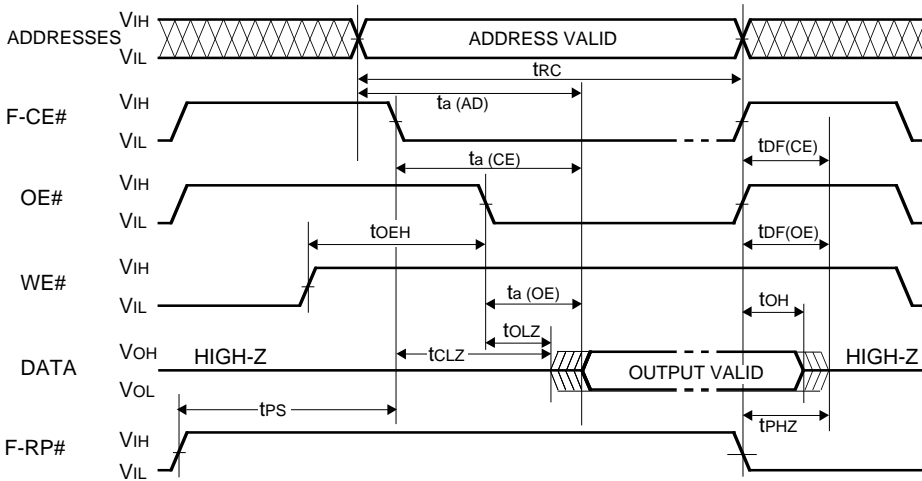

TEST CONDITIONS FOR AC CHARACTERISTICS

Input voltage : $V_{IL} = 0V$, $V_{IH} = 3.0V$
 Input rise and fall times : $\leq 5ns$
 Reference voltage at timing measurement : 1.5V

Output load : 1TTL gate + $CL(30pF)$

or

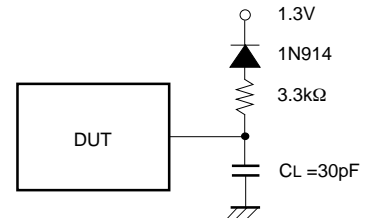

AC WAVEFORMS FOR WRITE FFH or 71H AND READ OPERATION

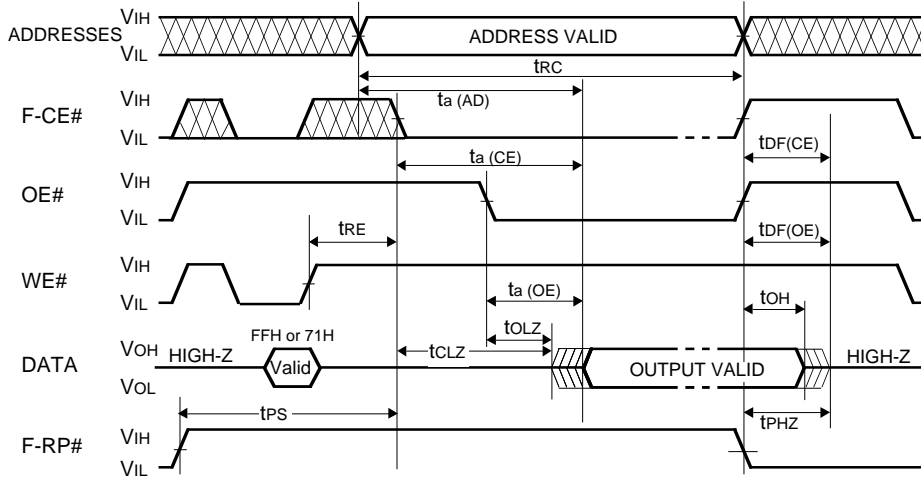

In the case of use F-CE# is Low fixed, it is allowed to define a timing specification of tRE from rising edge of WE# to falling edge of OE#, and valid data is read after spec of tRE+ta(CE). (This is only for FFH,71H program and read)

BYTE AC WAVEFORMS FOR READ OPERATION

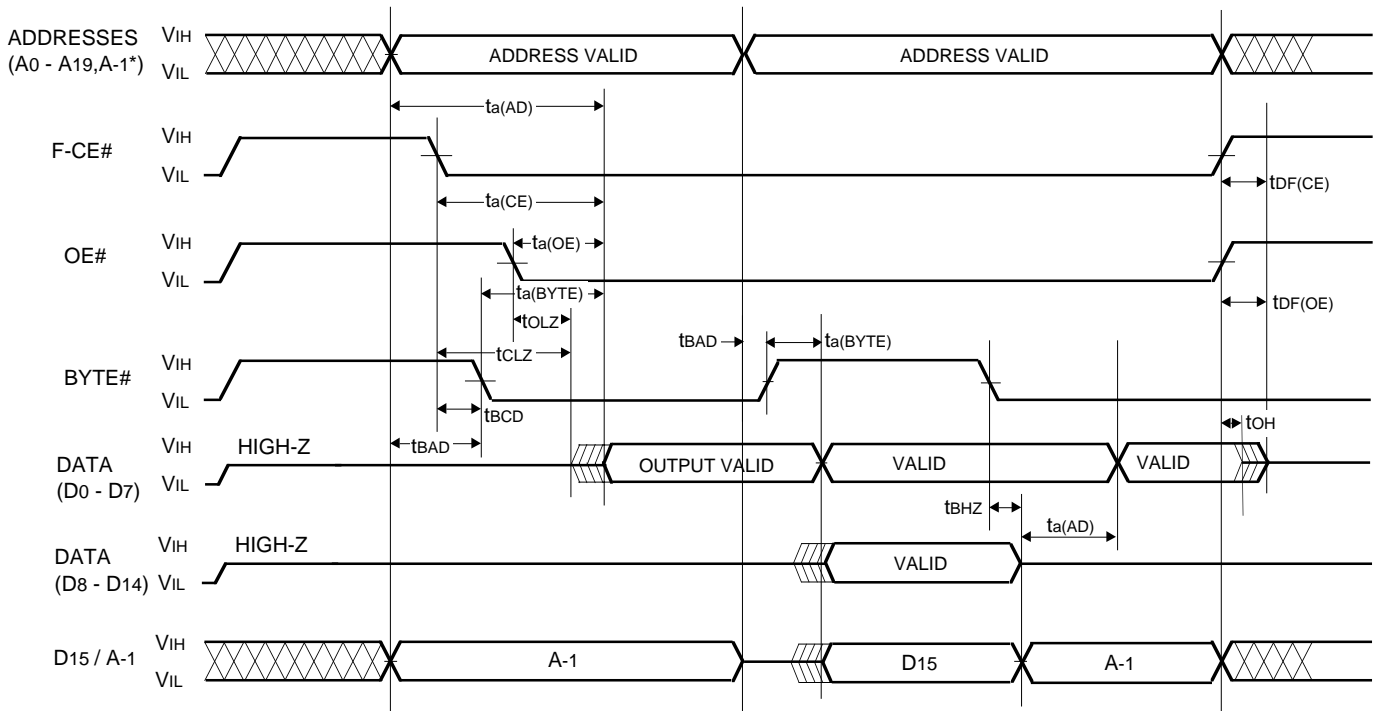

When BYTE#=VIH, F-CE#=OE#=VIL, D15/A-1 is output status. At this time, input signal must not be applied.

MITSUBISHI LSIs
M6MGB/T160S4BVP

16,777,216-BIT (1,048,576 -WORD BY 16-BIT / 2,097,152-WORD BY 8-BIT) CMOS
 3.3V-ONLY FLASH MEMORY &
 4,194,304-BIT (262,144WORD BY 16-BIT / 524,288-WORD BY 8-BIT) CMOS SRAM
 Stacked-MCP (Multi Chip Package)

AC WAVEFORMS FOR PAGE PROGRAM OPERATION (WE# control)

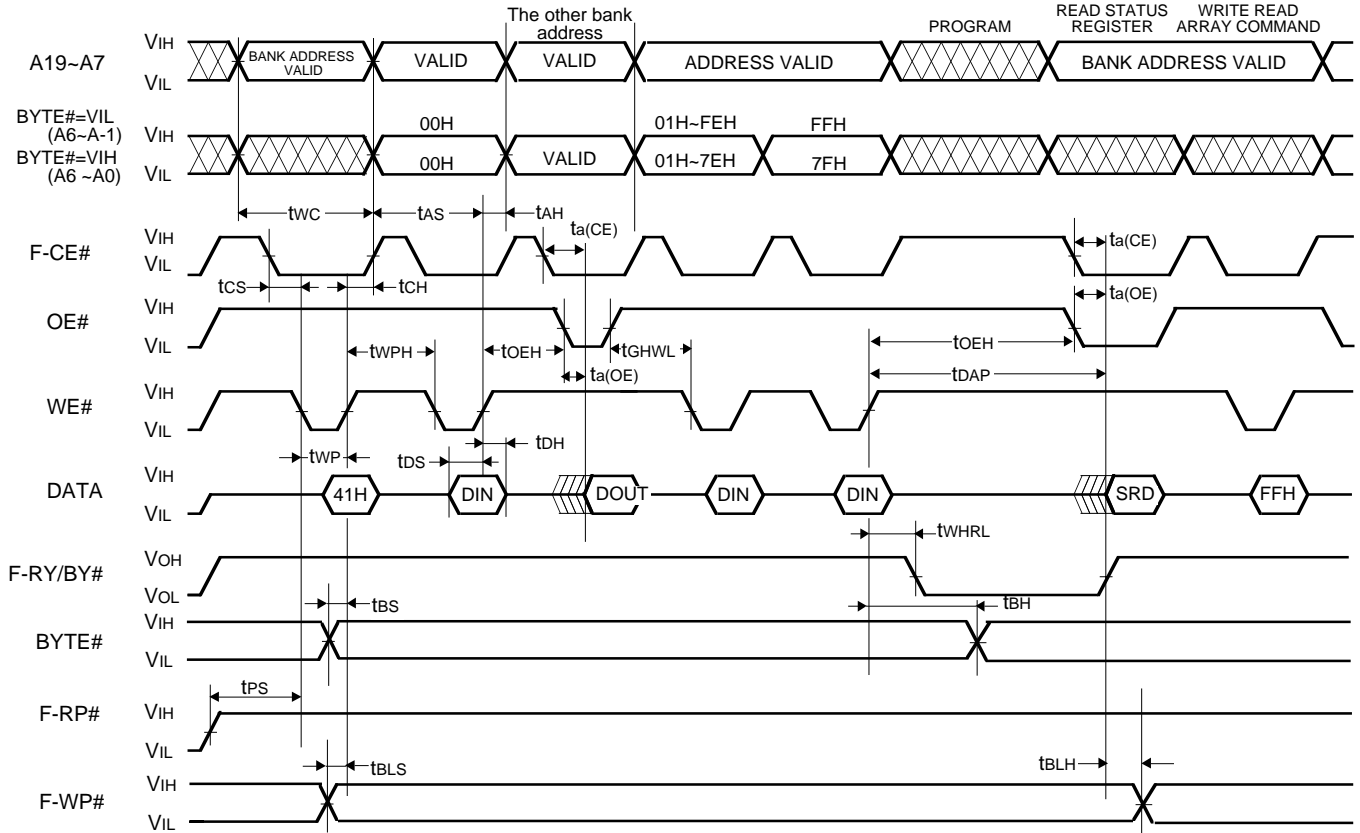

AC WAVEFORMS FOR PAGE PROGRAM OPERATION (F-CE# control)

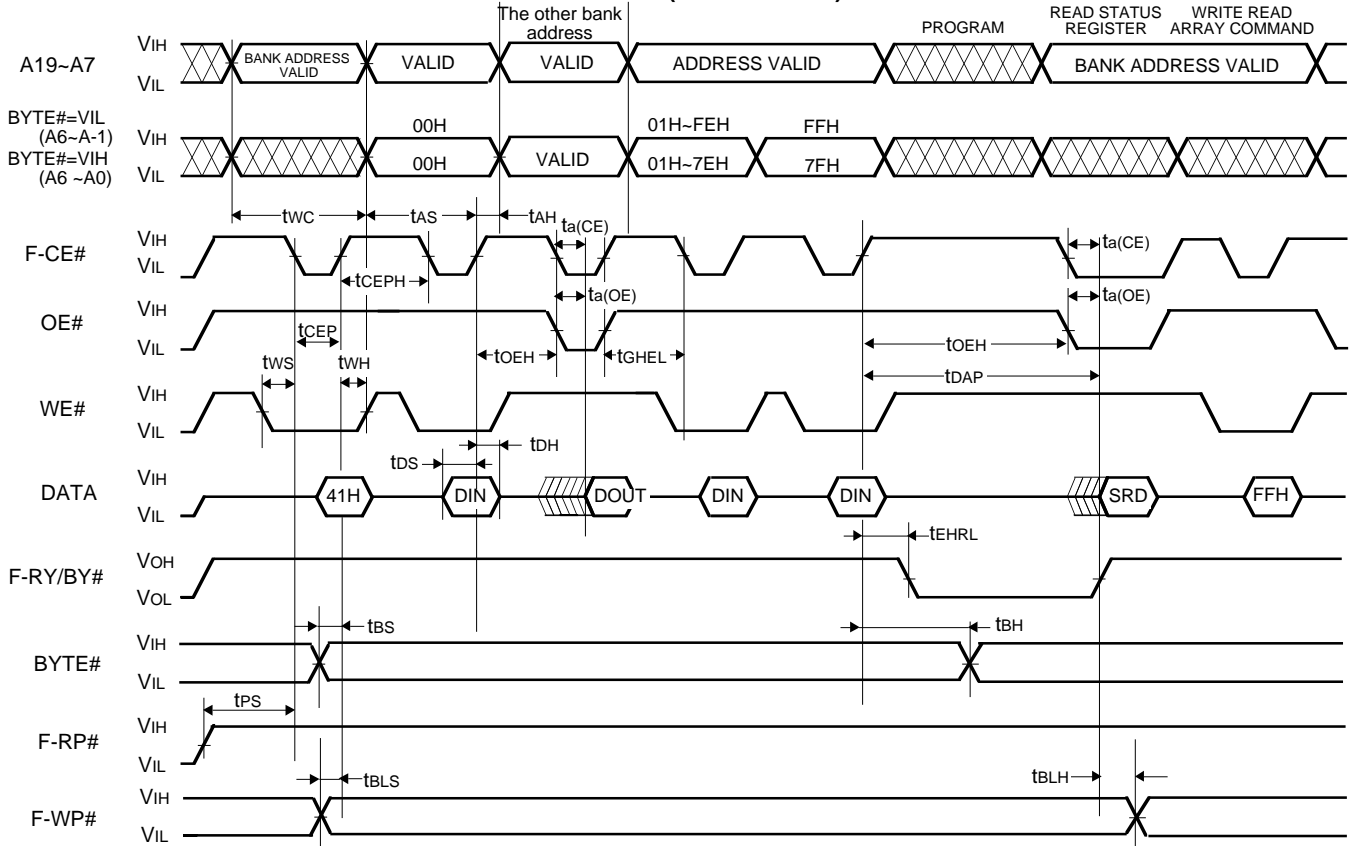

MITSUBISHI LSIs
M6MGB/T160S4BVP

16,777,216-BIT (1,048,576 -WORD BY 16-BIT / 2,097,152-WORD BY 8-BIT) CMOS
 3.3V-ONLY FLASH MEMORY &
 4,194,304-BIT (262,144WORD BY 16-BIT / 524,288-WORD BY 8-BIT) CMOS SRAM
 Stacked-MCP (Multi Chip Package)

AC WAVEFORMS FOR BYTE / WORD PROGRAM OPERATION (WE# control) (to only BANK(I))

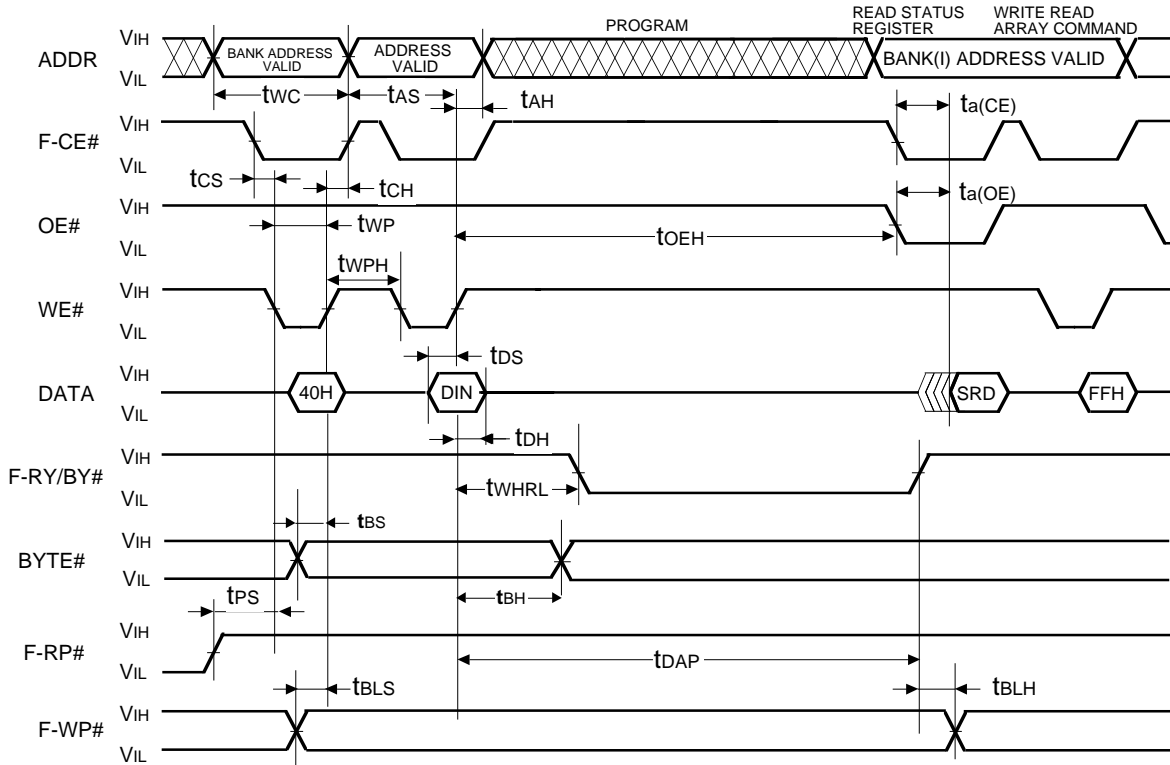

AC WAVEFORMS FOR BYTE / WORD PROGRAM OPERATION (F-CE# control) (to only BANK(I))

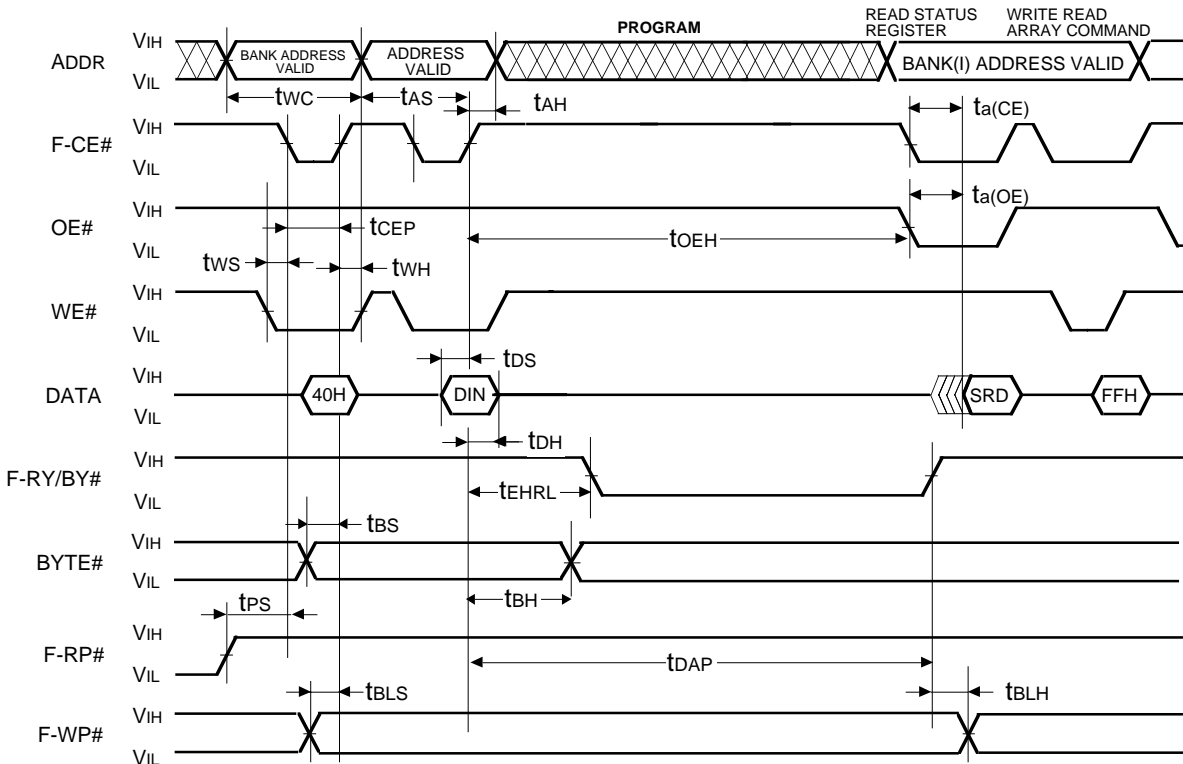

MITSUBISHI LSIs
M6MGB/T160S4BVP

16,777,216-BIT (1,048,576 -WORD BY 16-BIT / 2,097,152-WORD BY 8-BIT) CMOS
 3.3V-ONLY FLASH MEMORY &
 4,194,304-BIT (262,144WORD BY 16-BIT / 524,288-WORD BY 8-BIT) CMOS SRAM
 Stacked-MCP (Multi Chip Package)

AC WAVEFORMS FOR ERASE OPERATIONS (WE# control)

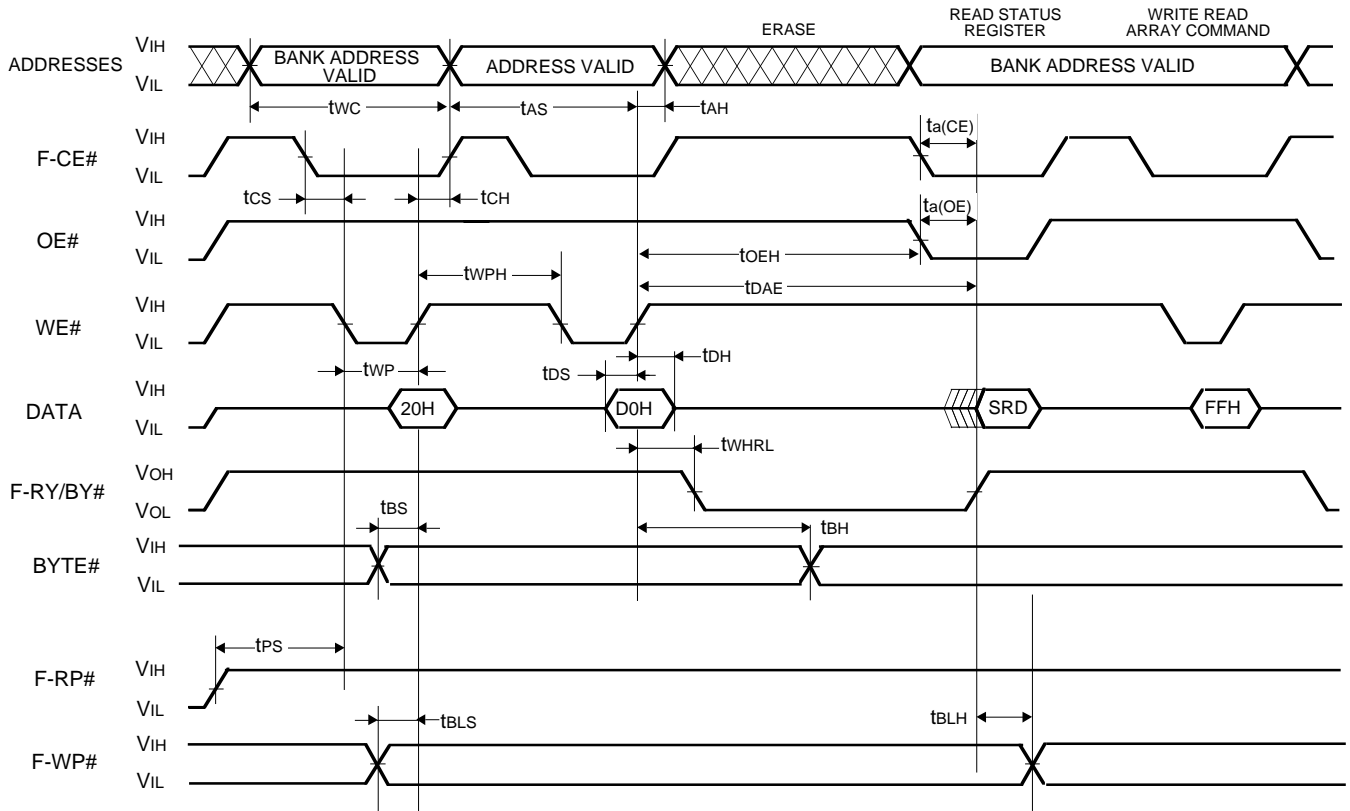

AC WAVEFORMS FOR ERASE OPERATIONS (F-CE# control)

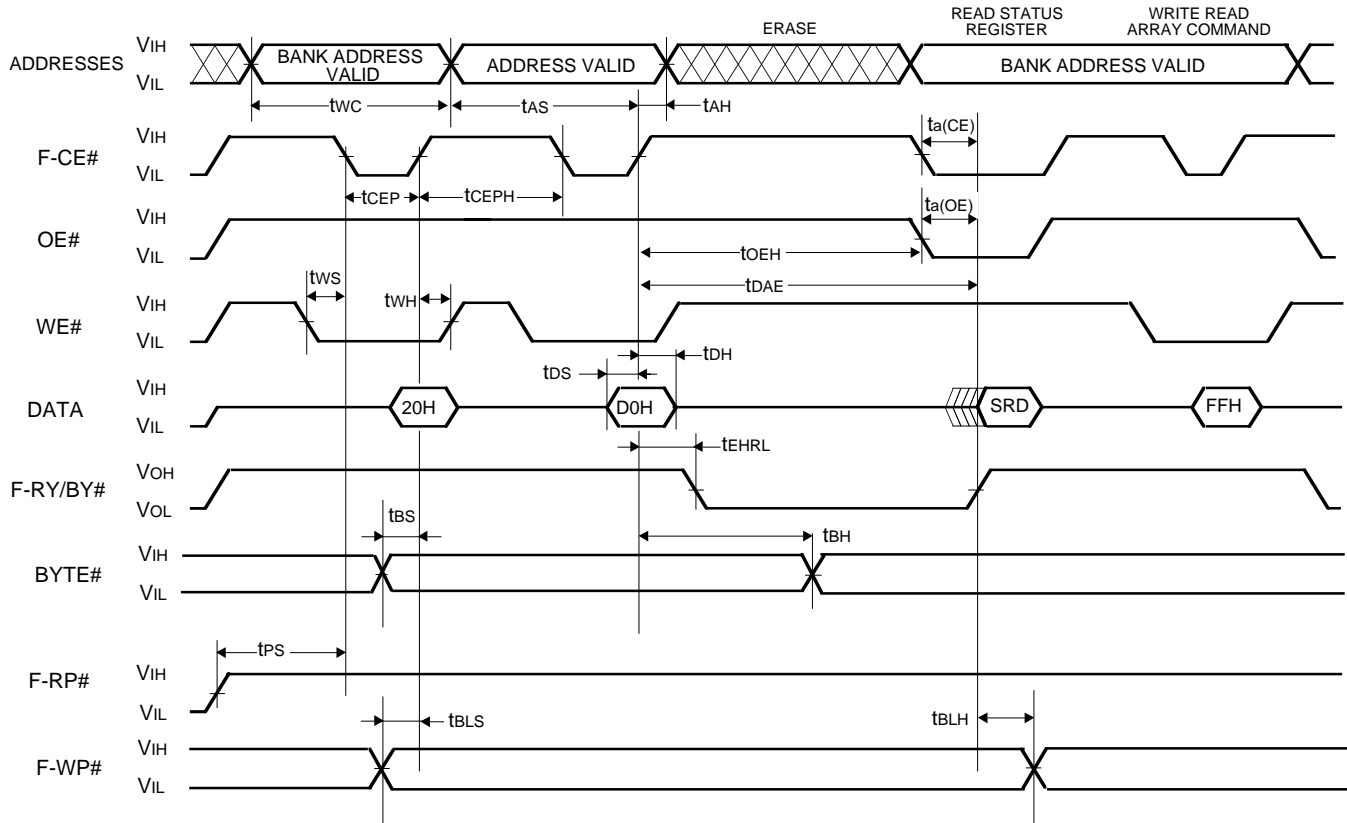

MITSUBISHI LSIs
M6MGB/T160S4BVP

16,777,216-BIT (1,048,576 -WORD BY 16-BIT / 2,097,152-WORD BY 8-BIT) CMOS
 3.3V-ONLY FLASH MEMORY &
 4,194,304-BIT (262,144WORD BY 16-BIT / 524,288-WORD BY 8-BIT) CMOS SRAM
 Stacked-MCP (Multi Chip Package)

AC WAVEFORMS FOR PAGE PROGRAM OPERATION WITH BGO (WE# control)

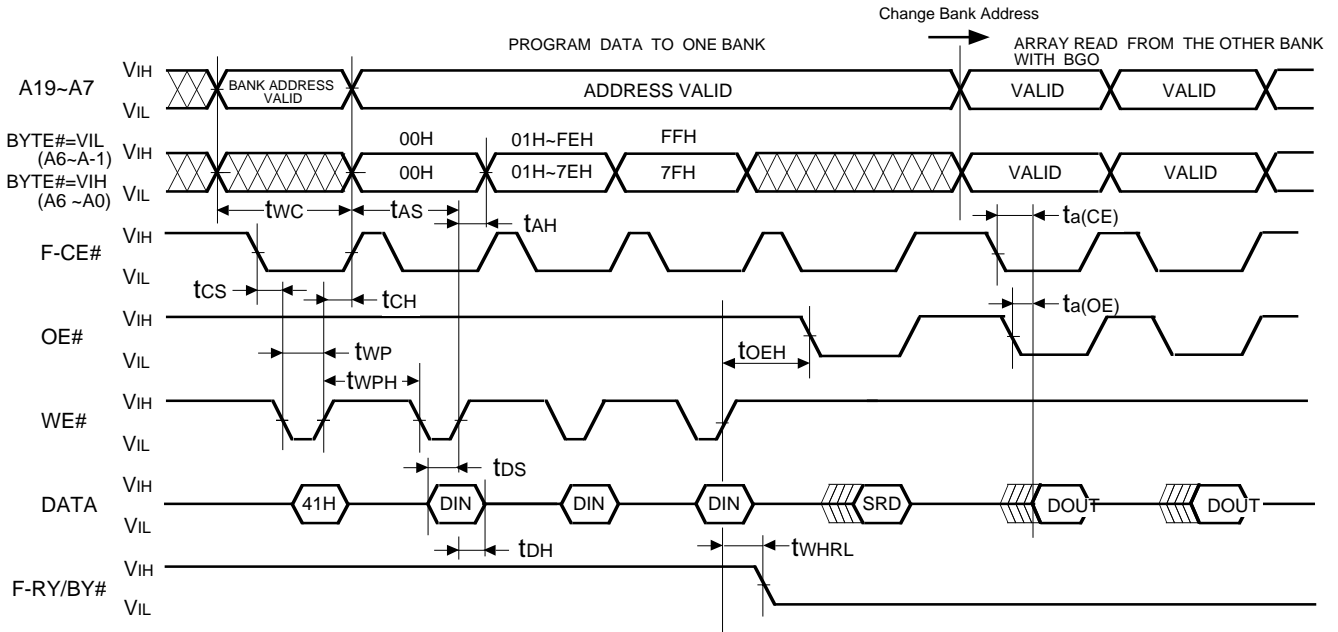

AC WAVEFORMS FOR PAGE PROGRAM OPERATION WITH BGO (F-CE# control)

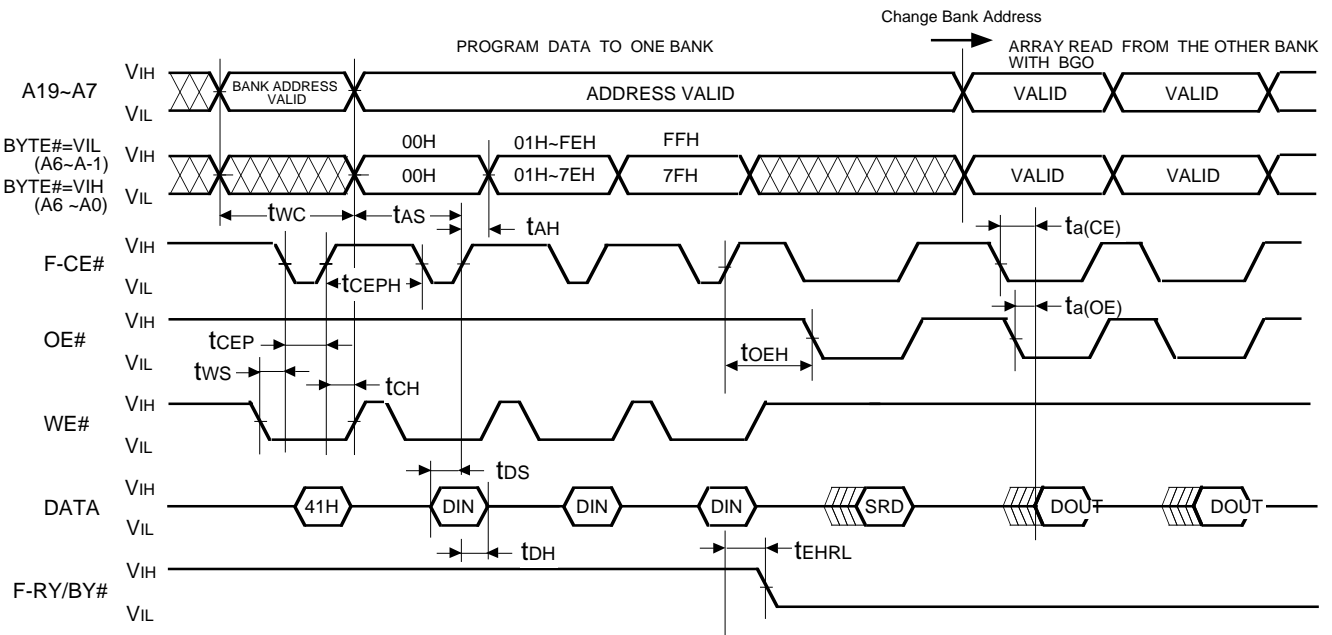

MITSUBISHI LSIs
M6MGB/T160S4BVP

16,777,216-BIT (1,048,576 -WORD BY 16-BIT / 2,097,152-WORD BY 8-BIT) CMOS
 3.3V-ONLY FLASH MEMORY &
 4,194,304-BIT (262,144WORD BY 16-BIT / 524,288-WORD BY 8-BIT) CMOS SRAM
 Stacked-MCP (Multi Chip Package)

AC WAVEFORMS FOR BYTE / WORD PROGRAM OPERATION WITH BGO (WE# control)

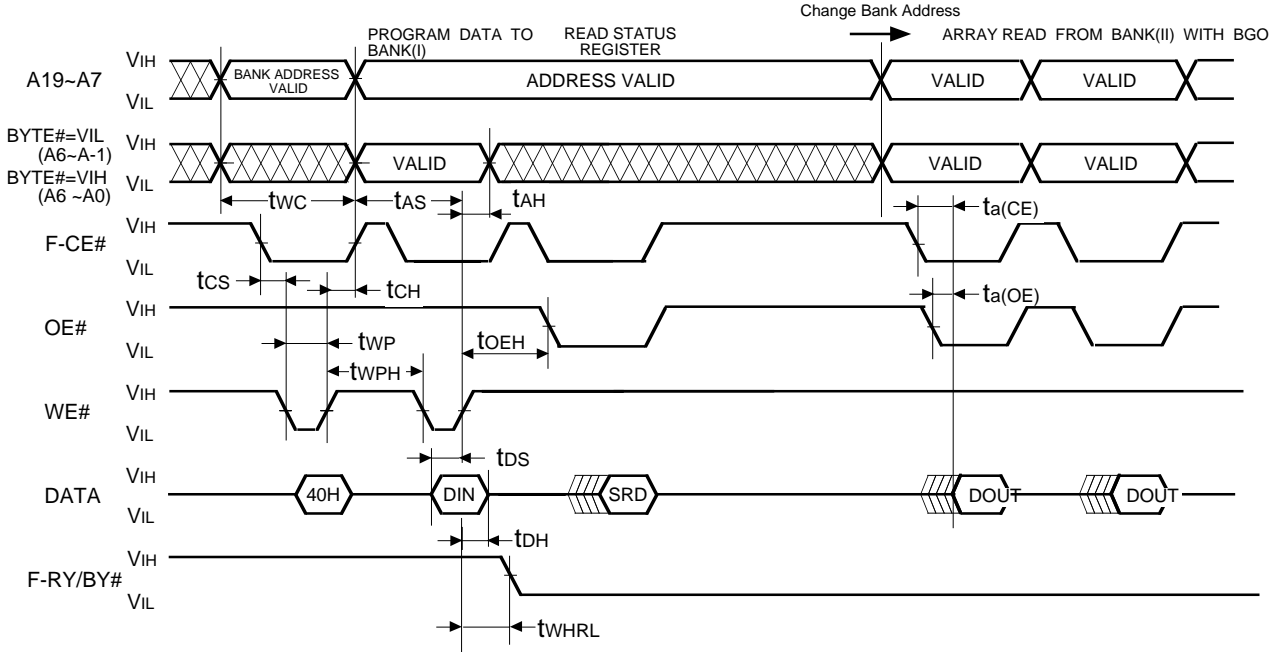

AC WAVEFORMS FOR BYTE / WORD PROGRAM OPERATION WITH BGO (F-CE# control)

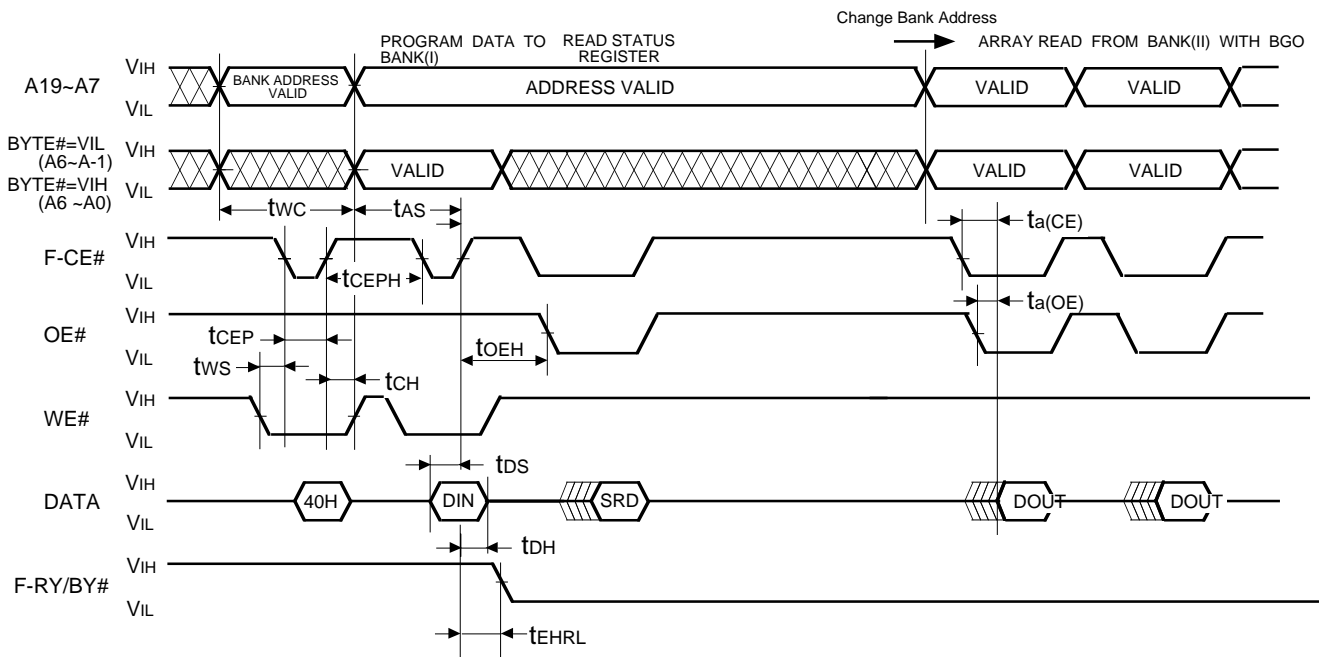

MITSUBISHI LSIs
M6MGB/T160S4BVP

16,777,216-BIT (1,048,576 -WORD BY 16-BIT / 2,097,152-WORD BY 8-BIT) CMOS
 3.3V-ONLY FLASH MEMORY &
 4,194,304-BIT (262,144WORD BY 16-BIT / 524,288-WORD BY 8-BIT) CMOS SRAM
 Stacked-MCP (Multi Chip Package)

AC WAVEFORMS FOR BLOCK ERASE OPERATION WITH BGO (WE# control)

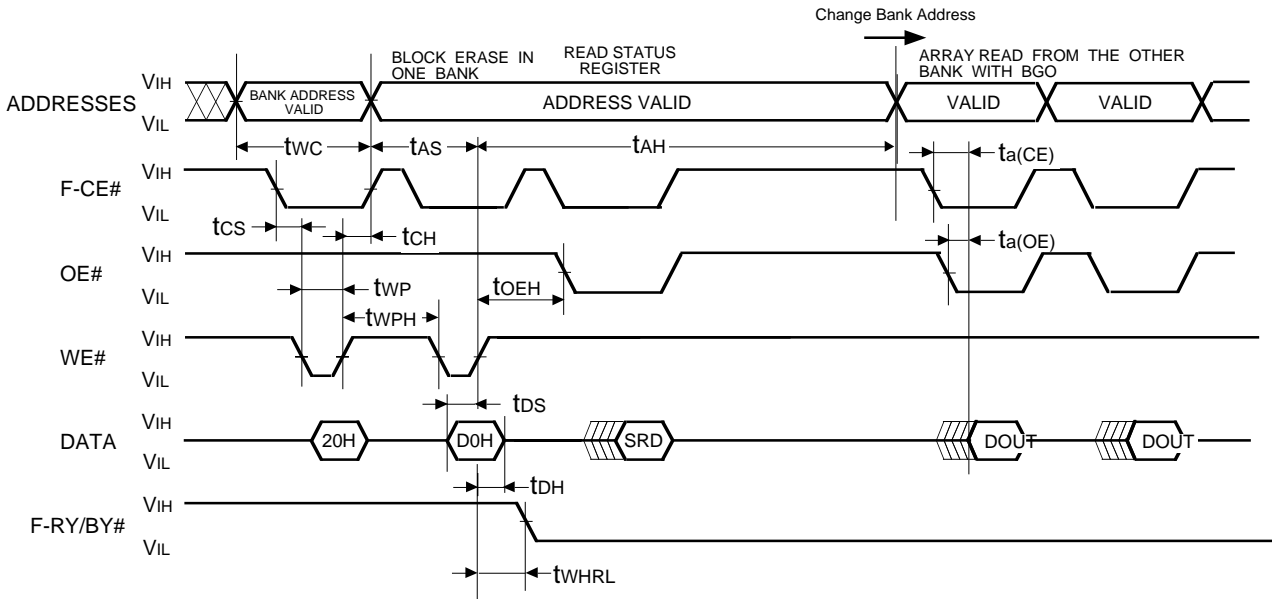

AC WAVEFORMS FOR BLOCK ERASE OPERATION WITH BGO (F-CE# control)

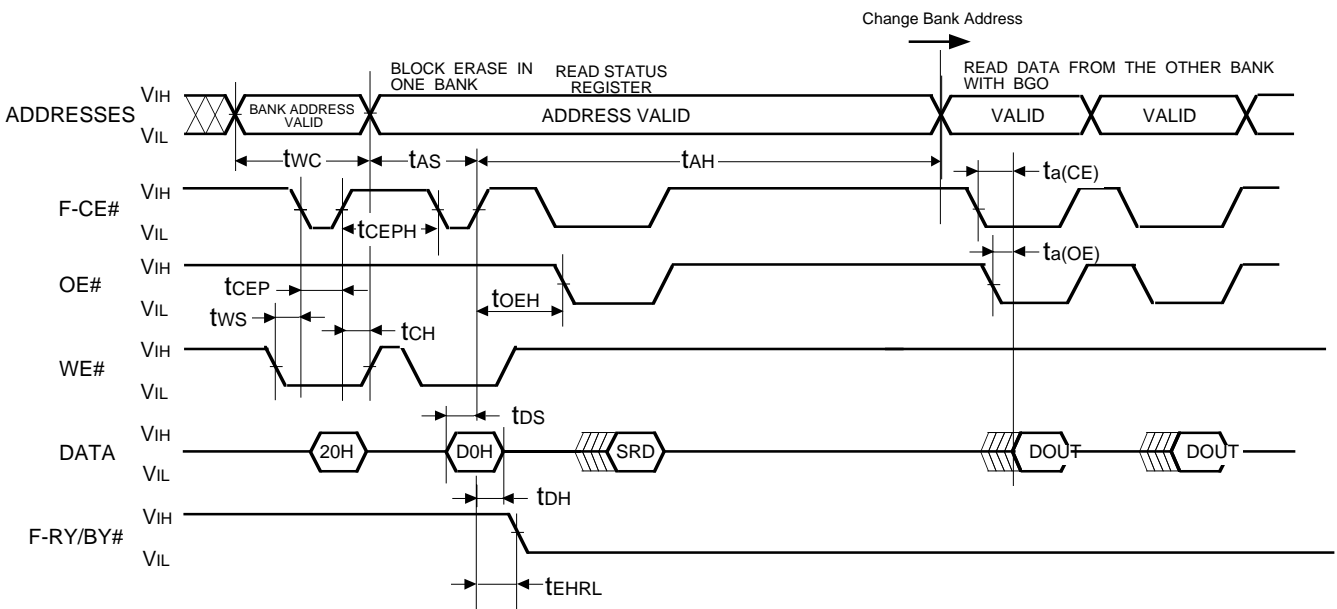

AC WAVEFORMS FOR SUSPEND OPERATION (WE# control)

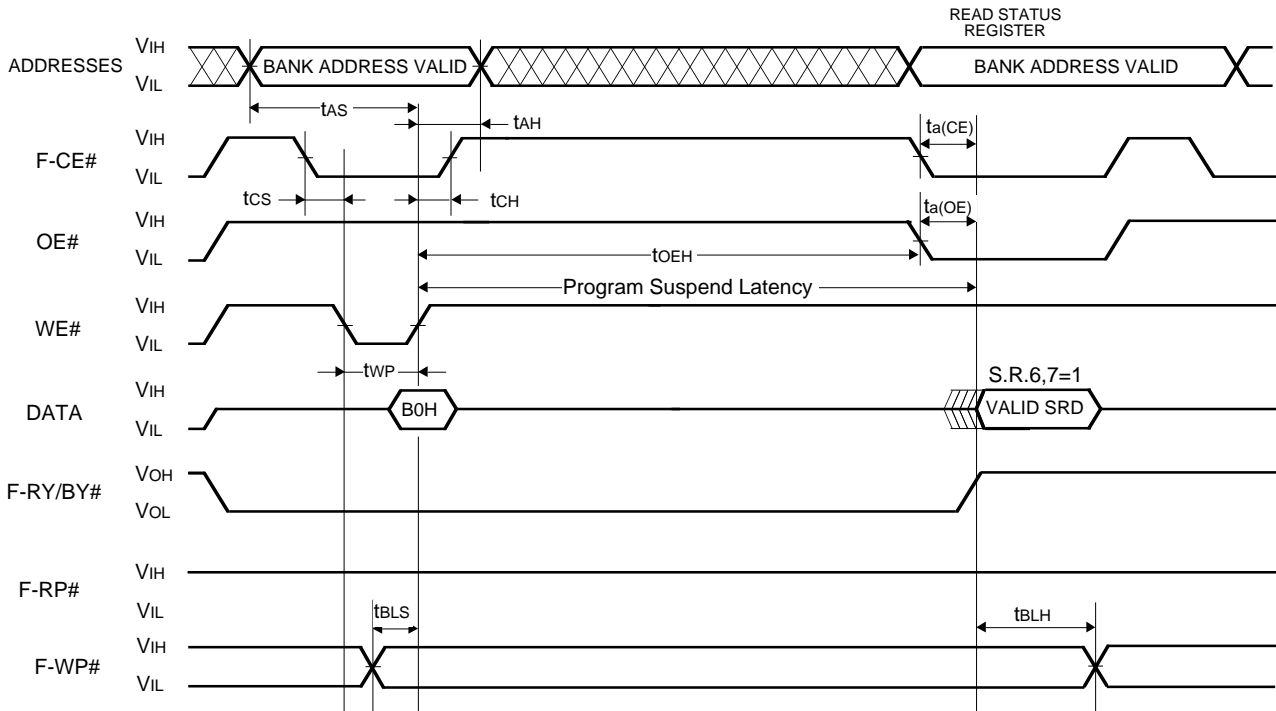

AC WAVEFORMS FOR SUSPEND OPERATION (F-CE# control)

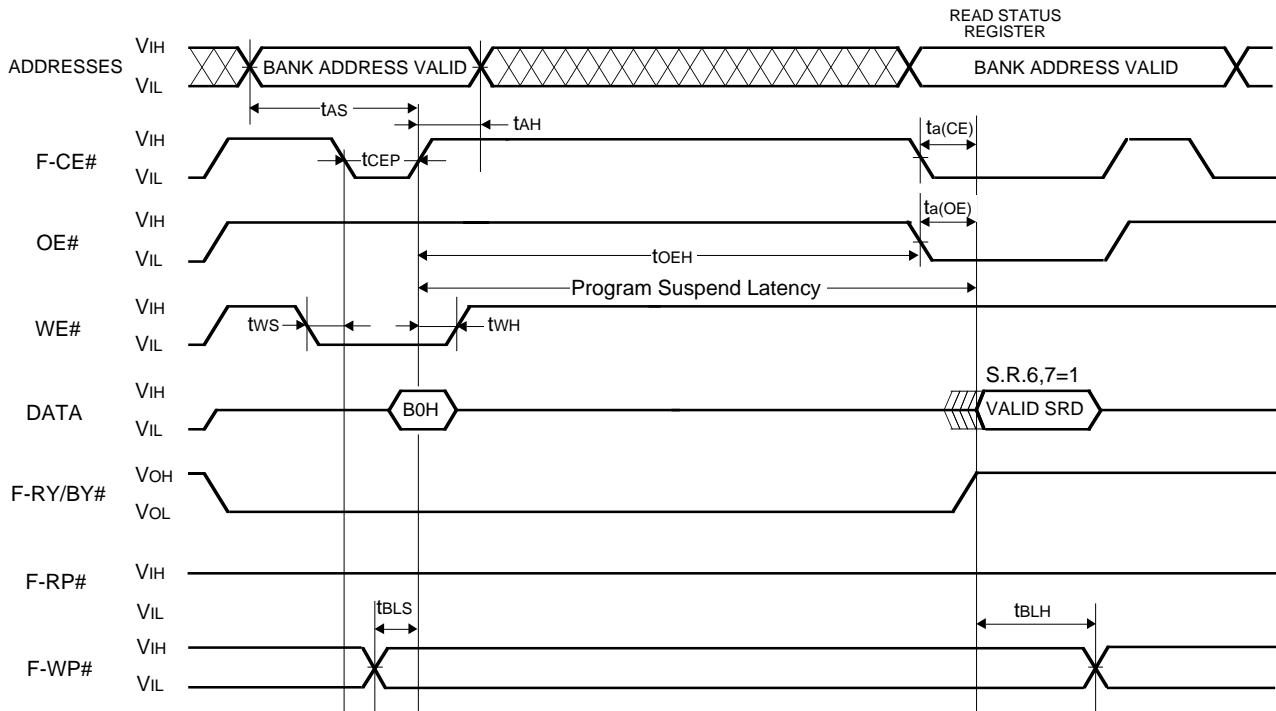

MITSUBISHI LSIs
M6MGB/T160S4BVP

16,777,216-BIT (1,048,576 -WORD BY 16-BIT / 2,097,152-WORD BY 8-BIT) CMOS
 3.3V-ONLY FLASH MEMORY &
 4,194,304-BIT (262,144WORD BY 16-BIT / 524,288-WORD BY 8-BIT) CMOS SRAM
 Stacked-MCP (Multi Chip Package)

FULL STATUS CHECK PROCEDURE

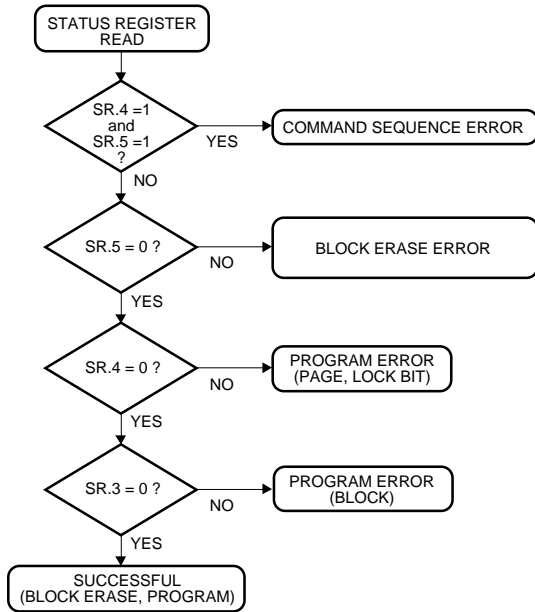

LOCK BIT PROGRAM FLOW CHART

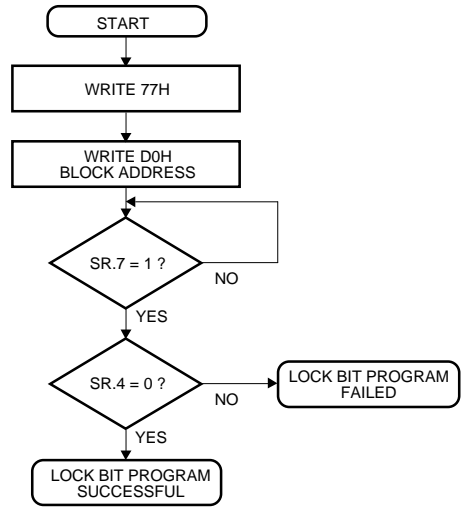

BYTE PROGRAM FLOW CHART

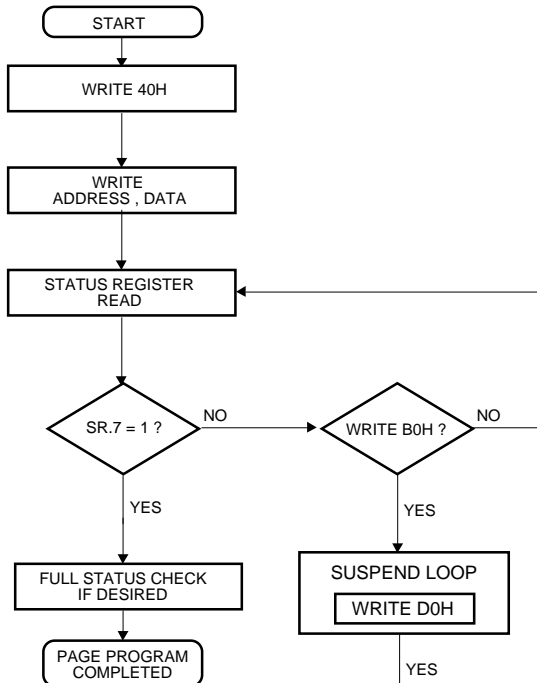

* Byte/Word program is admitted to only BANK(I).

PAGE PROGRAM FLOW CHART

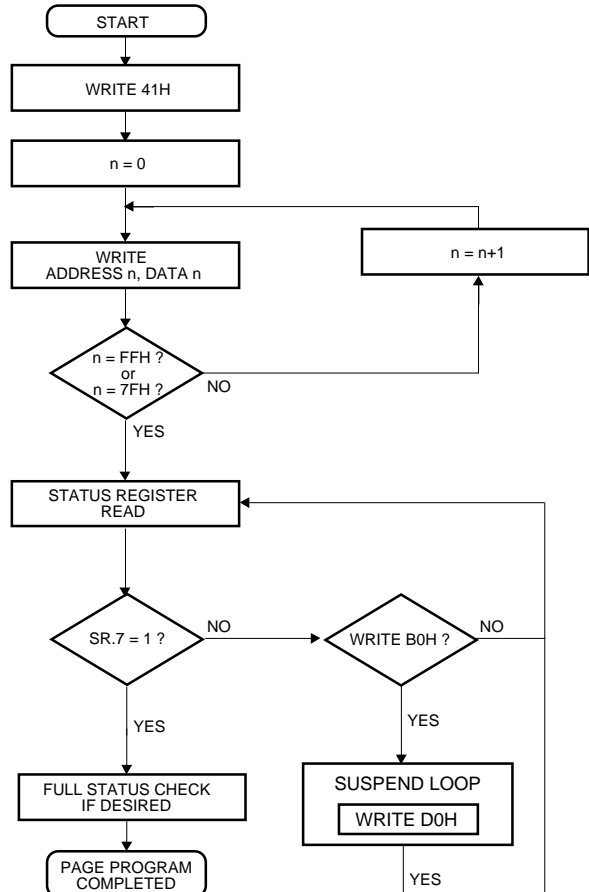

CLEAR PAGE BUFFER

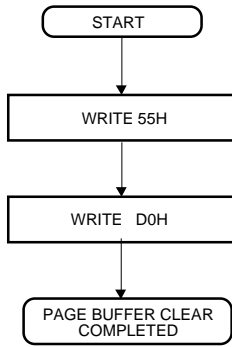

SINGLE DATA LOAD TO PAGE BUFFER

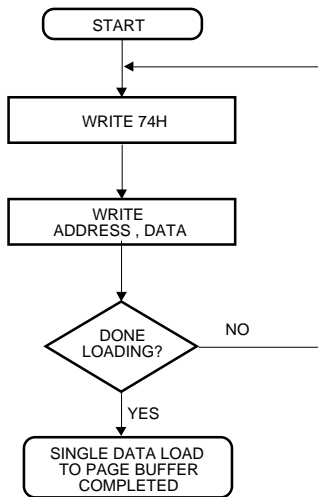

SUSPEND / RESUME FLOW CHART

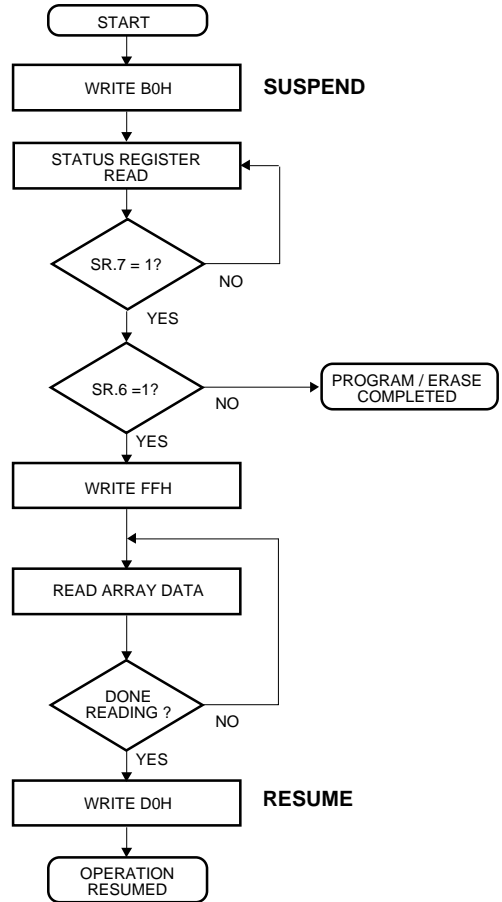

* The bank address is required when writing this command. Also, there is no need to suspend the erase or program operation when reading data from the other bank. Please use BGO function.

PAGE BUFFER TO FLASH

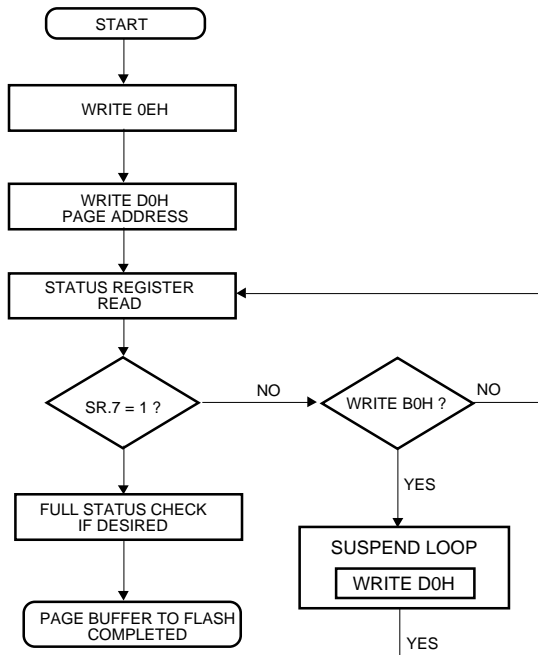

BLOCK ERASE FLOW CHART

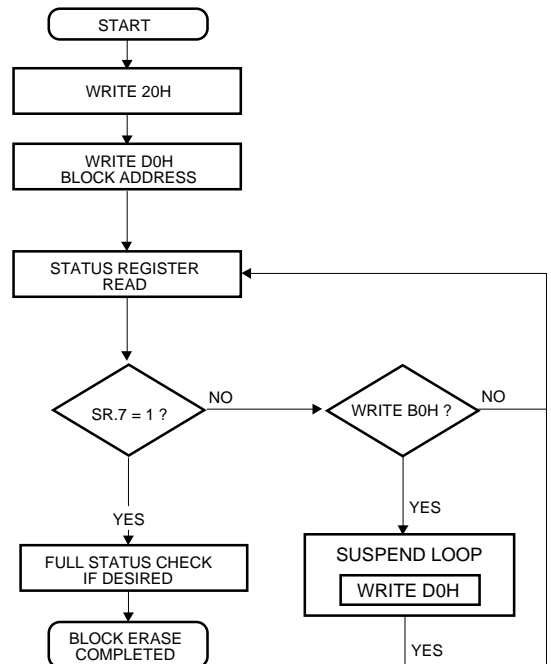

MITSUBISHI LSIS
M6MGB/T160S4BVP
 16,777,216-BIT (1,048,576 -WORD BY 16-BIT / 2,097,152-WORD BY 8-BIT) CMOS
 3.3V-ONLY FLASH MEMORY &
 4,194,304-BIT (262,144WORD BY 16-BIT / 524,288-WORD BY 8-BIT) CMOS SRAM
 Stacked-MCP (Multi Chip Package)

OPERATION STATUS and EFFECTIVE COMMAND

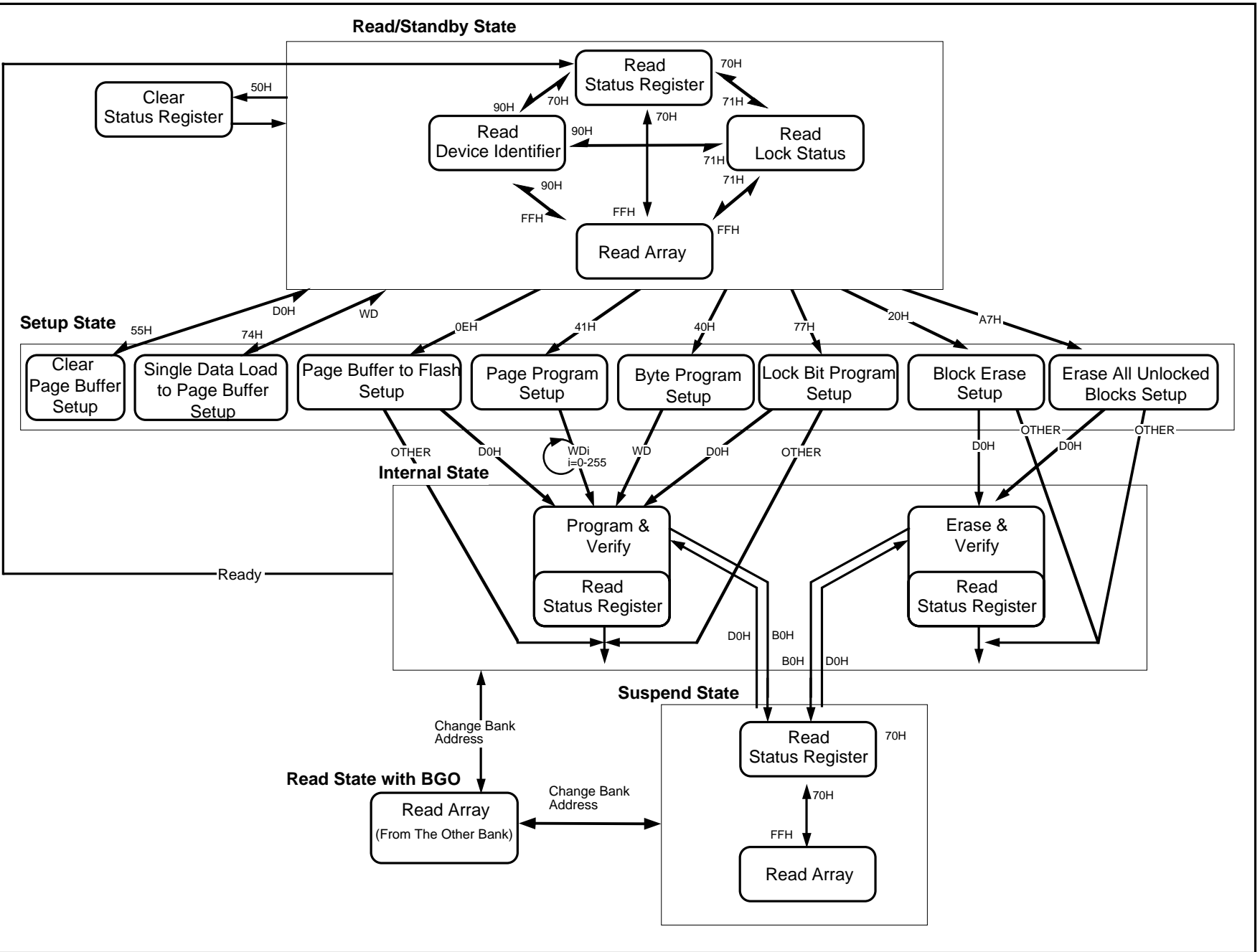

2. SRAM

The SRAM of M6MGB/T160S4BVP is organized as 262,144-word by 16-bit/ 524,288-word by 8-bit. These devices operate on a single +2.7~3.6V powersupply, and are directly TTL compatible to both input and output. Its fully static circuit needs no clocks and no refresh, and makes it useful.

The operation mode are determined by a combination of the device control inputs BYTE#, S-CE , WE# and OE#. Each mode is summarized in the function table.

A write operation is executed whenever the low level WE# overlaps with the high level S-CE. The address(A-1~A17:byte mode, A0~A17:word mode) must be set up before the write cycle and must be stable during the entire cycle.

A read operation is executed by setting WE# at a high level and OE# at a low level while S-CE are in an active state(S-CE=H).

When setting BYTE# at the low level and other pins are in an active stage , lower-byte I/O are in a selectable mode in which both reading and writing are enabled, and upper-byte are in a non-selectable mode.

When setting S-CE at a low level,the chips are in a non-selectable mode in which both reading and writing are disabled. In this mode, the output stage is in a high-impedance state, allowing OR-tie with other chips and memory expansion by S-CE.

The power supply current is reduced as low as 0.3μA(25 °C,typical), and the memory data can be held at +2V powersupply, enabling battery back-up operation during power failure or power-down operation in the non-selected mode.

FUNCTION TABLE

S-CE	BYTE#	WE#	OE#	Mode	DQ0~7	DQ8~15	Icc
L	X	X	X	Non selection	High-Z	High-Z	Standby
H	H	L	X	Write	Din	Din	Active
H	H	H	L	Read	Dout	Dout	Active
H	H	H	H	————	High-Z	High-Z	Active
H	L	L	X	Write	Din	High-Z	Active
H	L	H	L	Read	Dout	High-Z	Active
H	L	H	H	————	High-Z	High-Z	Active

MITSUBISHI LSIs
M6MGB/T160S4BVP

16,777,216-BIT (1,048,576 -WORD BY 16-BIT / 2,097,152-WORD BY 8-BIT) CMOS
3.3V-ONLY FLASH MEMORY &
4,194,304-BIT (262,144WORD BY 16-BIT / 524,288-WORD BY 8-BIT) CMOS SRAM
Stacked-MCP (Multi Chip Package)

ABSOLUTE MAXIMUM RATINGS

Symbol	Parameter	Conditions	Ratings	Units
S-V _{CC}	Supply voltage	With respect to GND	-0.5* ~ +4.6	V
V _I	Input voltage	With respect to GND	-0.5* ~ S-V _{CC} + 0.5	
V _O	Output voltage	With respect to GND	0 ~ S-V _{CC}	
P _d	Power dissipation	T _a =25°C	700	mW
T _a	Operating temperature	W-version	- 20 ~ +85	°C
T _{stg}	Storage temperature		- 65 ~ +150	°C

* -3.0V in case of AC (Pulse width ≤ 30ns)

DC ELECTRICAL CHARACTERISTICS

(S-V_{CC}=2.7 ~ 3.6V, unless otherwise noted)

Symbol	Parameter	Conditions	Limits			Units	
			Min	Typ	Max		
V _{IH}	High-level input voltage		2.2		S-V _{CC} +0.3V	V	
V _{IL}	Low-level input voltage		-0.3 *		0.6		
V _{OH1}	High-level output voltage 1	I _{OH} = -0.5mA	2.4				
V _{OH2}	High-level output voltage 2	I _{OH} = -0.05mA	S-V _{CC} -0.5V				
V _{OL}	Low-level output voltage	I _{OL} =2mA			0.4	μA	
I _I	Input leakage current	V _I =0 ~ S-V _{CC}			±1		
I _O	Output leakage current	S-CE=V _{IL} or OE#=V _{IH} , V _{I/O} =0 ~ S-V _{CC}			±1	mA	
I _{CC1}	Active supply current (AC,MOS level)	S-CE ≥ S-V _{CC} -0.2V other inputs ≤ 0.2V or ≥ S-V _{CC} -0.2V Output - open (duty 100%)	f= 10MHz	-	50		70
			f= 1MHz	-	7		15
I _{CC2}	Active supply current (AC,TTL level)	S-CE=V _{IH} other pins =V _{IH} or V _{IL} Output - open (duty 100%)	f= 10MHz	-	50		70
			f= 1MHz	-	7	15	
I _{CC3}	Stand by supply current (AC,MOS level)	S-CE ≤ 0.2V Other inputs=0~S-V _{CC}	-W	+70 ~ +85°C	-	-	40
				+40 ~ +70°C	-	-	20
				+25 ~ +40°C	-	1	3.6
				- 20 ~ +25°C	-	0.3	1.2
I _{CC4}	Stand by supply current (AC,TTL level)	S-CE=V _{IL} Other inputs= 0 ~ S-V _{CC}	-	-	0.5	mA	

Note 1: Direction for current flowing into IC is indicated as positive (no mark)

* -3.0V in case of AC (Pulse width ≤ 30ns)

Note 2: Typical value is for S-V_{CC}=3.0V and T_a=25°C

CAPACITANCE

(S-V_{CC}=2.7 ~ 3.6V, unless otherwise noted)

Symbol	Parameter	Conditions	Limits			Units
			Min	Typ	Max	
C _i	Input capacitance	V _I =GND, V _I =25mVrms, f=1MHz			10	pF
C _o	Output capacitance	V _O =GND, V _O =25mVrms, f=1MHz			10	

Note: The value of common pins to SRAM is the sum of Flash Memory and SRAM.

MITSUBISHI LSIs
M6MGB/T160S4BVP

16,777,216-BIT (1,048,576 -WORD BY 16-BIT / 2,097,152-WORD BY 8-BIT) CMOS
3.3V-ONLY FLASH MEMORY &
4,194,304-BIT (262,144WORD BY 16-BIT / 524,288-WORD BY 8-BIT) CMOS SRAM
Stacked-MCP (Multi Chip Package)

AC ELECTRICAL CHARACTERISTICS (S-V_{CC}=2.7 ~ 3.6V, unless otherwise noted)

(1) TEST CONDITIONS

Supply voltage	2.7V~3.6V
Input pulse	V _{IH} =2.4V, V _{IL} =0.4V
Input rise time and fall time	5ns
Reference level	V _{OH} =V _{OL} =1.5V Transition is measured ±500mV from steady state voltage.(for t _{en} ,t _{dis})
Output loads	Fig.1,CL=30pF CL=5pF (for t _{en} ,t _{dis})

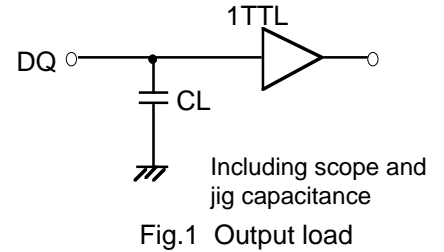

(2) READ CYCLE

Symbol	Parameter	Limits		Units
		SRAM		
		Min	Max	
t _{CR}	Read cycle time	85		ns
t _{a(A)}	Address access time		85	ns
t _{a(CE)}	Chip select access time		85	ns
t _{a(OE)}	Output enable access time		45	ns
t _{dis(CE)}	Output disable time after S-CE low		30	ns
t _{dis(OE)}	Output disable time after OE# high		30	ns
t _{en(CE)}	Output enable time after S-CE high	10		ns
t _{en(OE)}	Output enable time after OE# low	5		ns
t _{v(A)}	Data valid time after address	10		ns

(3) WRITE CYCLE

Symbol	Parameter	Limits		Units
		SRAM		
		Min	Max	
t _{CW}	Write cycle time	85		ns
t _{w(W)}	Write pulse width	60		ns
t _{su(A)}	Address setup time	0		ns
t _{su(A-WH)}	Address setup time with respect to WE#	70		ns
t _{su(CE)}	Chip select setup time	70		ns
t _{su(D)}	Data setup time	35		ns
t _{h(D)}	Data hold time	0		ns
t _{rec(W)}	Write recovery time	0		ns
t _{dis(W)}	Output disable time from WE# low		30	ns
t _{dis(OE)}	Output disable time from OE# high		30	ns
t _{en(W)}	Output enable time from WE# high	5		ns
t _{en(OE)}	Output enable time from OE# low	5		ns

(4)TIMING DIAGRAMS

Read cycle

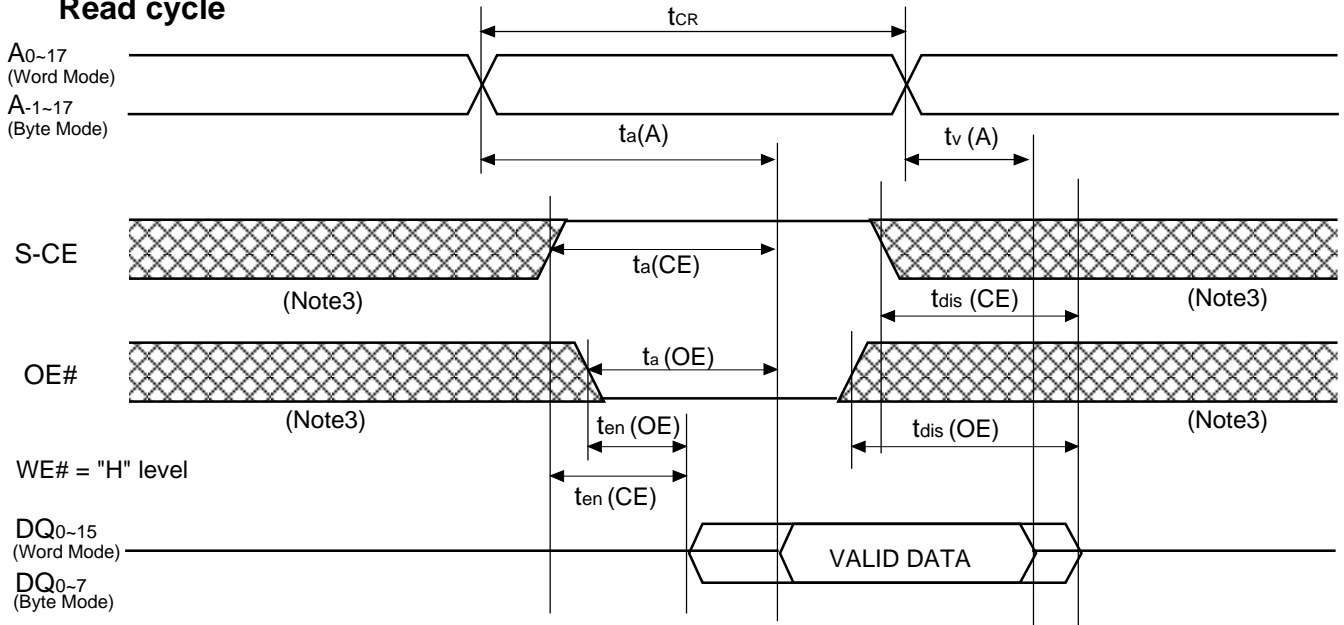

Write cycle (WE# control mode)

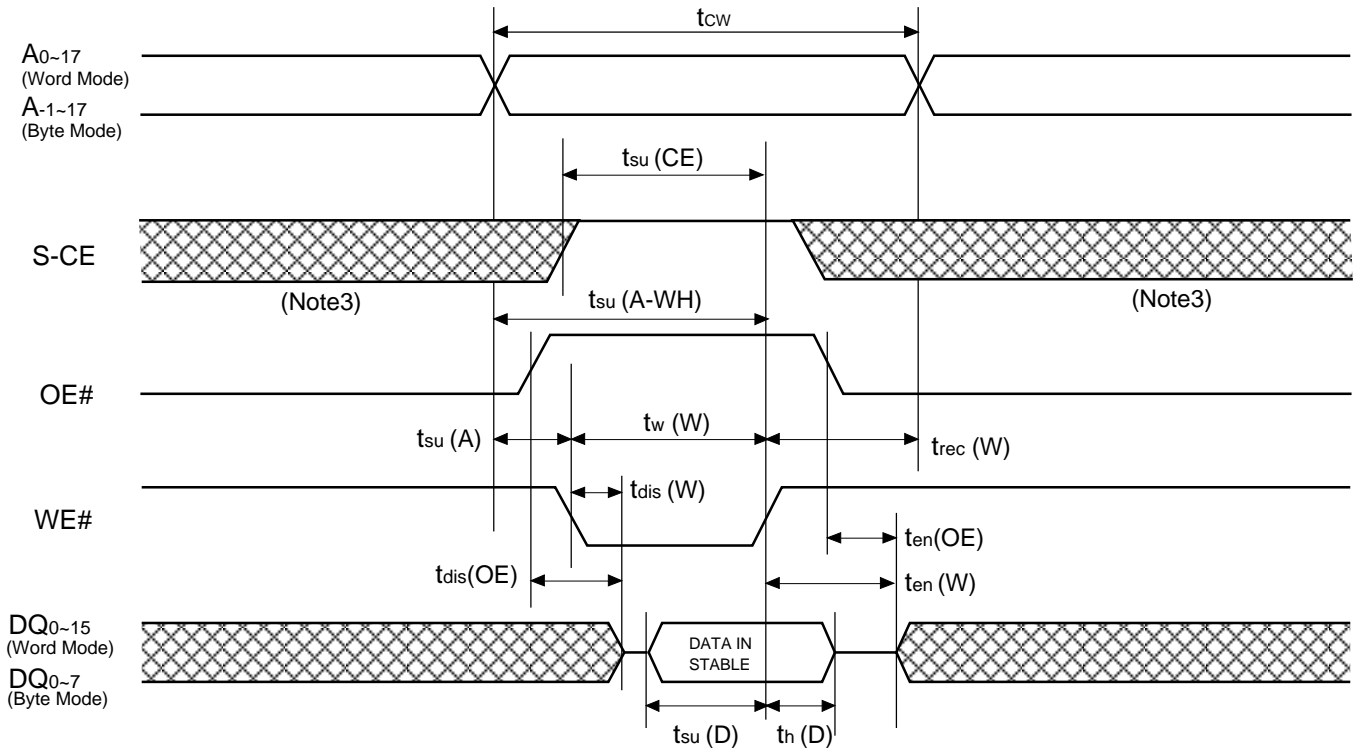

Write cycle (S-CE control mode)

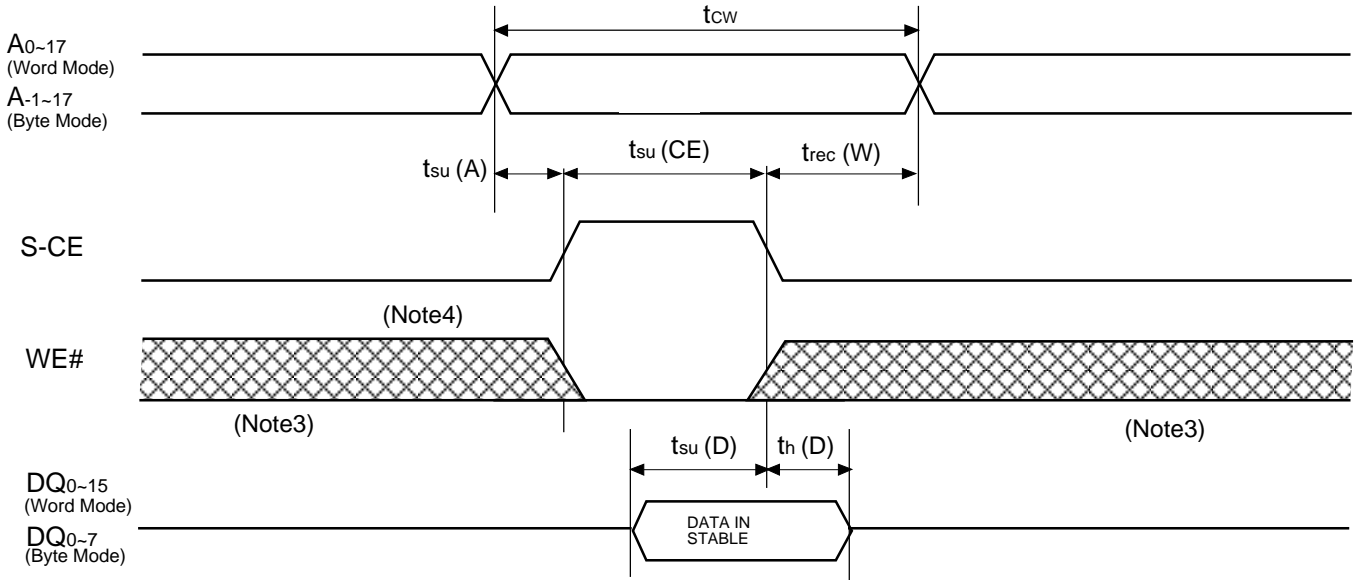

Note 3: Hatching indicates the state is "don't care".

Note 4: When the falling edge of WE# is simultaneously or prior to the rising edge of S-CE, the outputs are maintained in the high impedance state.

Note 5: Don't apply inverted phase signal externally when DQ pin is in output mode.

POWER DOWN CHARACTERISTICS

(1) ELECTRICAL CHARACTERISTICS

Symbol	Parameter	Test conditions		Limits			Units	
				Min	Typ	Max		
S-V _{cc} (PD)	Power down supply voltage			2.0			V	
V _I (S-CE)	Chip select input S-CE					0.2	V	
I _{cc} (PD)	Power down supply current	S-V _{cc} =3.0V S-CE ≤ 0.2V other inputs=0-3V	-W	+70 ~ +85°C	-	-	30	μA
				+40 ~ +70°C	-	-	15	μA
				+25 ~ +40°C	-	1	3	μA
				-20 ~ +25°C	-	0.3	1	μA

Typical value is for Ta=25°C

(2) TIMING REQUIREMENTS

Symbol	Parameter	Test conditions	Limits			Units
			Min	Typ	Max	
t _{su} (PD)	Power down set up time		0			ns
t _{rec} (PD)	Power down recovery time		5			ms

(3) TIMING DIAGRAM

S-CE control mode

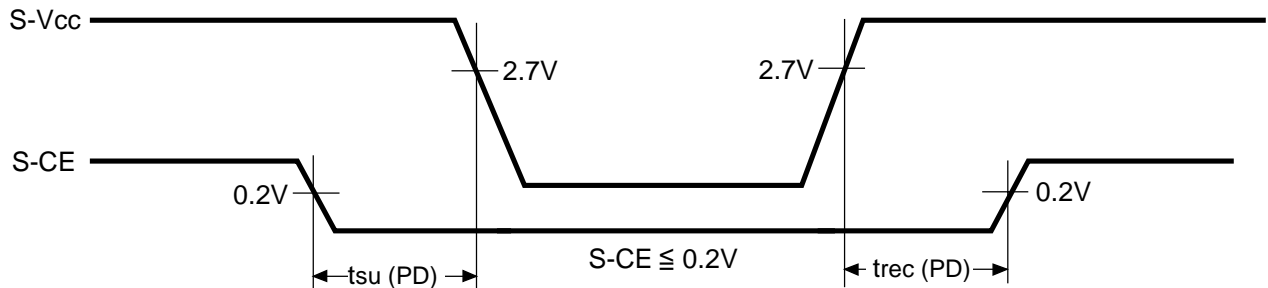

BYTE# TIMING DIAGRAM

(1) TIMING REQUIREMENTS

Symbol	Parameter	Test conditions	Limits			Units
			Min	Typ	Max	
t _{su} (BYTE)	BYTE# set up time		5			ms
t _{rec} (BYTE)	BYTE# recovery time		5			ms

(2) TIMING DIAGRAM

