

Advanced Information

Notice: This is not final specification.
Some parametric limits are subject to change.

M5M5Y5636TG – 25,22,20**18874368-BIT(524288-WORD BY 36-BIT) NETWORK SRAM****DESCRIPTION**

The M5M5Y5636TG is a family of 18M bit synchronous SRAMs organized as 524288-words by 36-bit. It is designed to eliminate dead bus cycles when turning the bus around between reads and writes, or writes and reads. Mitsubishi's SRAMs are fabricated with high performance, low power CMOS technology, providing greater reliability. M5M5Y5636TG operates on a single 1.8V power supply and are 1.8V CMOS compatible.

FEATURES

- Fully registered inputs and outputs for pipelined operation
- Fast clock speed: 250, 225, and 200 MHz
- Fast access time: 2.6, 2.8, 3.2 ns
- Single 1.8V +150/-100mV power supply V_{DD}
- Separate V_{DDQ} for 1.8V I/O
- Individual byte write (BWA# - BWD#) controls may be tied LOW
- Single Read/Write control pin (W#)
- Echo Clock outputs track data output drivers
- ZQ mode pin for user-selectable output drive strength
- 2 User programmable chip enable inputs for easy depth expansion
- Linear or Interleaved Burst Modes
- JTAG boundary scan support

APPLICATION

High-end networking products that require high bandwidth, such as switches and routers.

PACKAGE

	Bump	Body Size	Bump Pitch
M5M5Y5636TG	209(11X19) bump BGA	14mm X 22mm	1mm

PART NAME TABLE

Part Name	Frequency	Access	Cycle	Active Current (max.)	Standby Current (max.)
M5M5Y5636TG -25	250MHz	2.6ns	4.0ns	400mA	20mA
M5M5Y5636TG -22	225MHz	2.8ns	4.4ns	380mA	20mA
M5M5Y5636TG -20	200MHz	3.2ns	5.0ns	360mA	20mA

FUNCTION

Synchronous circuitry allows for precise cycle control triggered by a positive edge clock transition.

Synchronous signals include : all Addresses, all Data Inputs, all Chip Enables (E1#, E2, E3), Address Advance/Load (ADV), Byte Write Enables (BWA#, BWB#, BWC#, BWD#), Echo Clock outputs (CQ1, CQ1#, CQ2, CQ2#) and Read/Write (W#). Write operations are controlled by the eight Byte Write Enables (BWA# - BWD#) and Read/Write(W#) inputs. All writes are conducted with on-chip synchronous self-timed write circuitry.

The Echo Clocks are delayed copies of the RAM clock, CLK. Echo Clocks are designed to track changes in output driver delays due to variance in die temperature and supply voltage.

The ZQ pin supplied with selectable impedance drivers, allows selection between nominal drive strength (ZQ LOW) for multi-drop bus application and low drive strength (ZQ floating or HIGH) point-to-point applications.

The sense of two User-Programmable Chip Enable inputs (E2, E3), whether they function as active LOW or active HIGH inputs, is determined by the state of the programming inputs, EP2 and EP3.

The Linear Burst order (LBO#) is DC operated pin. LBO# pin will allow the choice of either an interleaved burst, or a linear burst.

All read, write and deselect cycles are initiated by the ADV Low input. Subsequent burst address can be internally generated as controlled by the ADV HIGH input.



BUMP LAYOUT(TOP VIEW)

209 bump BGA

	1	2	3	4	5	6	7	8	9	10	11
A	NC	NC	A6	E2	A7	ADV	A8	E3	A9	DQb	DQb
B	NC	NC	BWc#	NC	A18	W#	A17	BWb#	NC	DQb	DQb
C	NC	NC	NC	BWd#	NC	E1#	NC	NC	BWa#	DQb	DQb
D	NC	NC	Vss	NC	NC	MCL	NC	NC	Vss	DQb	DQb
E	NC	DQPc	VDDQ	VDDQ	VDD	VDD	VDD	VDDQ	VDDQ	NC	DQPb
F	DQc	DQc	Vss	Vss	Vss	ZQ	Vss	Vss	Vss	NC	NC
G	DQc	DQc	VDDQ	VDDQ	VDD	EP2	VDD	VDDQ	VDDQ	NC	NC
H	DQc	DQc	Vss	Vss	Vss	EP3	Vss	Vss	Vss	NC	NC
J	DQc	DQc	VDDQ	VDDQ	VDD	MCH	VDD	VDDQ	VDDQ	NC	NC
K	CQ2	CQ2#	CLK	NC	Vss	MCL	Vss	NC	NC	CQ1#	CQ1
L	NC	NC	VDDQ	VDDQ	VDD	MCH	VDD	VDDQ	VDDQ	DQa	DQa
M	NC	NC	Vss	Vss	Vss	MCL	Vss	Vss	Vss	DQa	DQa
N	NC	NC	VDDQ	VDDQ	VDD	MCH	VDD	VDDQ	VDDQ	DQa	DQa
P	NC	NC	Vss	Vss	Vss	MCL	Vss	Vss	Vss	DQa	DQa
R	DQPd	NC	VDDQ	VDDQ	VDD	VDD	VDD	VDDQ	VDDQ	DQPd	NC
T	DQd	DQd	Vss	NC	NC	LBO#	NC	NC	Vss	NC	NC
U	DQd	DQd	NC	A3	NC	A15	NC	A11	NC	NC	NC
V	DQd	DQd	A5	A4	A16	A1	A13	A12	A10	NC	NC
W	DQd	DQd	TMS	TDI	A2	A0	A14	TDO	TCK	NC	NC

Note1. MCH means "Must Connect High". MCH should be connected to HIGH.
 Note2. MCL means "Must Connect Low". MCL should be connected to LOW.



BLOCK DIAGRAM

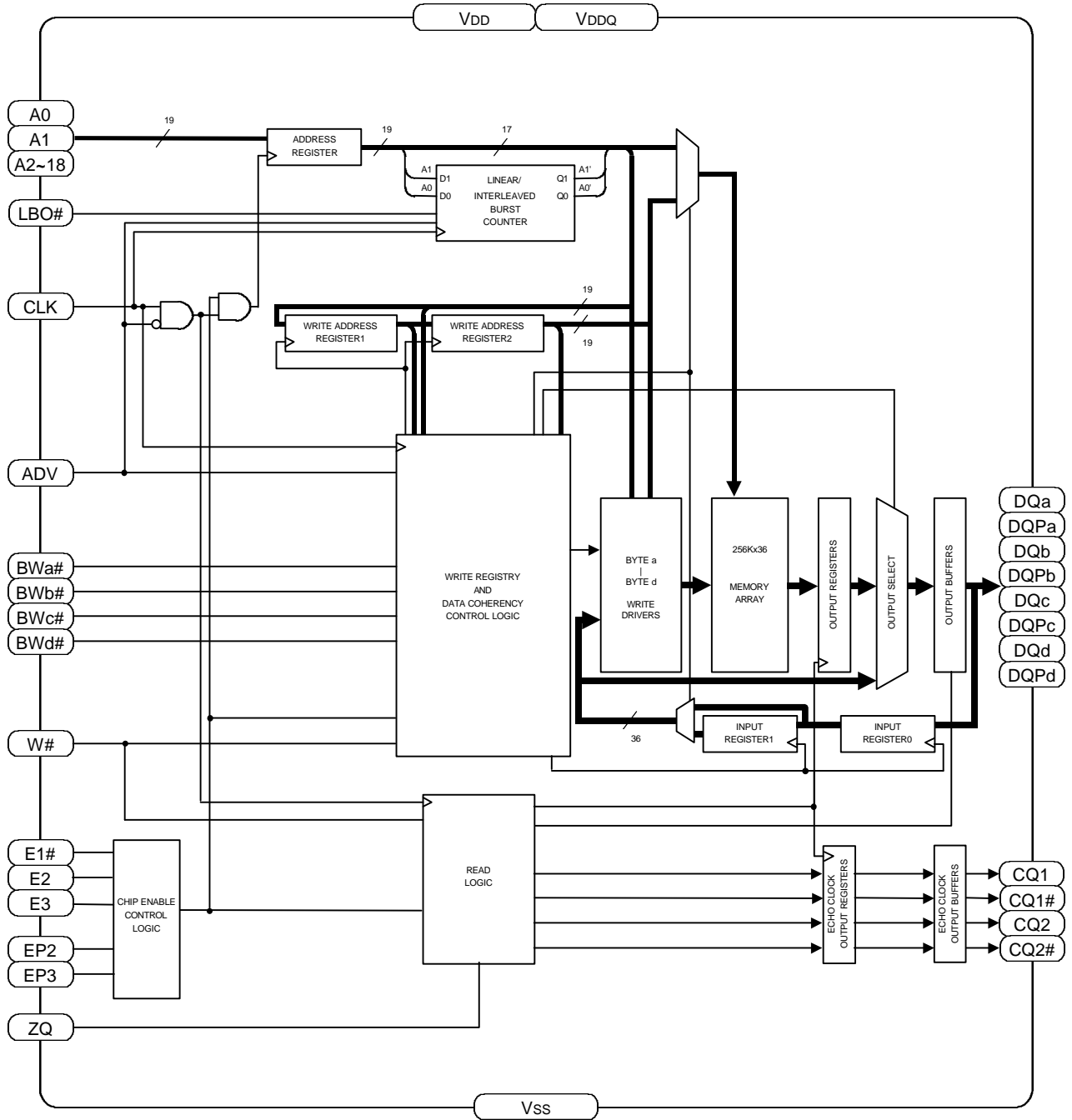

Note3. The BLOCK DIAGRAM does not include the Boundary Scan logic. See Boundary Scan chapter.

Note4. The BLOCK DIAGRAM illustrates simplified device operation. See TRUTH TABLE, PIN FUNCTION and timing diagrams for detailed information.



PIN FUNCTION

Pin	Name	Function
A0~A18	Synchronous Address Inputs	These inputs are registered and must meet the setup and hold times around the rising edge of CLK. A0 and A1 are the two least significant bits (LSB) of the address field and set the internal burst counter if burst is desired.
BWa#, BWb#, BWc#, BWd#	Synchronous Byte Write Enables	These active LOW inputs allow individual bytes to be written when a WRITE cycle is active and must meet the setup and hold times around the rising edge of CLK. BYTE WRITES need to be asserted on the same cycle as the address. BWa are associated with addresses and apply to subsequent data. BWa# controls DQa, DQP a pins; BWb# controls DQb, DQP b pins; BWc# controls DQc, DQP c pins; BWd# controls DQd, DQP d pins.
CLK	Clock Input	This signal registers the address, data, chip enables, byte write enables and burst control inputs on its rising edge. All synchronous inputs must meet setup and hold times around the clock's rising edge.
E1#	Synchronous Chip Enable	This active LOW input is used to enable the device and is sampled only when a new external address is loaded (ADV is LOW).
E2, E3	Synchronous Chip Enable	These pins are user-programmable chip enable inputs. The sense of the inputs, whether they function as active LOW or HIGH inputs, is determined by the state of the programming inputs, EP2 and EP3.
EP2, EP3	Chip Enable Program Pin	These pins determine the sense of the user-programmable chip enable inputs, whether they function as active LOW or active HIGH inputs.
ADV	Synchronous Address Advance/Load	When HIGH, this input is used to advance the internal burst counter, controlling burst access after the external address is loaded. When HIGH, W# is ignored. A LOW on this pin permits a new address to be loaded at CLK rising edge.
CQ1, CQ1#, CQ2, CQ2#	Echo Clock Outputs	The Echo Clocks are delayed copies of the main RAM clock, CLK.
ZQ	Output Impedance Control	This pin allows selection between RAM nominal drive strength (ZQ low) for multi-drop bus applications and low drive strength (ZQ floating or high) point-to-point application.
W#	Synchronous Read/Write	This active input determines the cycle type when ADV is LOW. This is the only means for determining READs and WRITEs. READ cycles may not be converted into WRITEs (and vice versa) other than by loading a new address. A LOW on the pin permits BYTE WRITE operations and must meet the setup and hold times around the rising edge of CLK. Full bus width WRITEs occur if all byte write enables are LOW.
DQa,DQP a,DQb,DQP b,DQc,DQP c,DQd,DQP d	Synchronous Data I/O	Byte "a" is DQa , DQP a pins; Byte "b" is DQb, DQP b pins; Byte "c" is DQc, DQP c pins; Byte "d" is DQd,DQP d pins. Input data must meet setup and hold times around CLK rising edge.
LBO#	Burst Mode Control	This DC operated pin allows the choice of either an interleaved burst or a linear burst. If this pin is HIGH or NC, an interleaved burst occurs. When this pin is LOW, a linear burst occurs, and input leak current to this pin.
VDD	VDD	Core Power Supply
VSS	VSS	Ground
VDDQ	VDDQ	I/O buffer Power supply
TDI	Test Data Input	These pins are used for Boundary Scan Test.
TDO	Test Data Output	
TCK	Test Clock	
TMS	Test Mode Select	
MCH	Must Connect High	These pins should be connected to HIGH
MCL	Must Connect Low	These pins should be connected to LOW
NC	No Connect	These pins are not internally connected and may be connected to ground.



Read Operation

Pipelined Read

Read operation is initiated when the following conditions are satisfied at the rising edge of clock: All three chip enables (E1#, E2 and E3) are active, the write enable input signal (W#) is deasserted high, and ADV is asserted low. The address presented to the address inputs is latched into the address register and presented to the memory core and control logic. The control logic determines that a read access is in progress and allows the requested data to propagate to the input of the output register. At the next rising edge of clock the read data is allowed to propagate through the output register and onto the output pins.

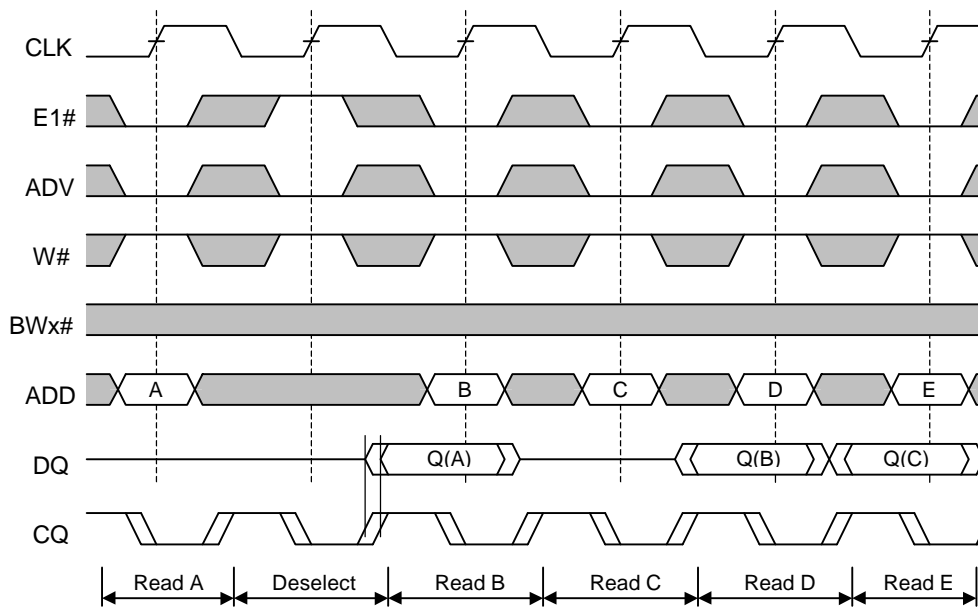

Write Operation

Double Late Write

Write operation occurs when the following conditions are satisfied at the rising edge of clock: All three chip enables (E1#, E2 and E3) are active and the write enable input signal (W#) is asserted low.

Double Late Write means that Data In is required on the third rising edge of clock. It is designed to eliminate dead bus cycles when turning the bus around between reads and writes, or writes and reads.

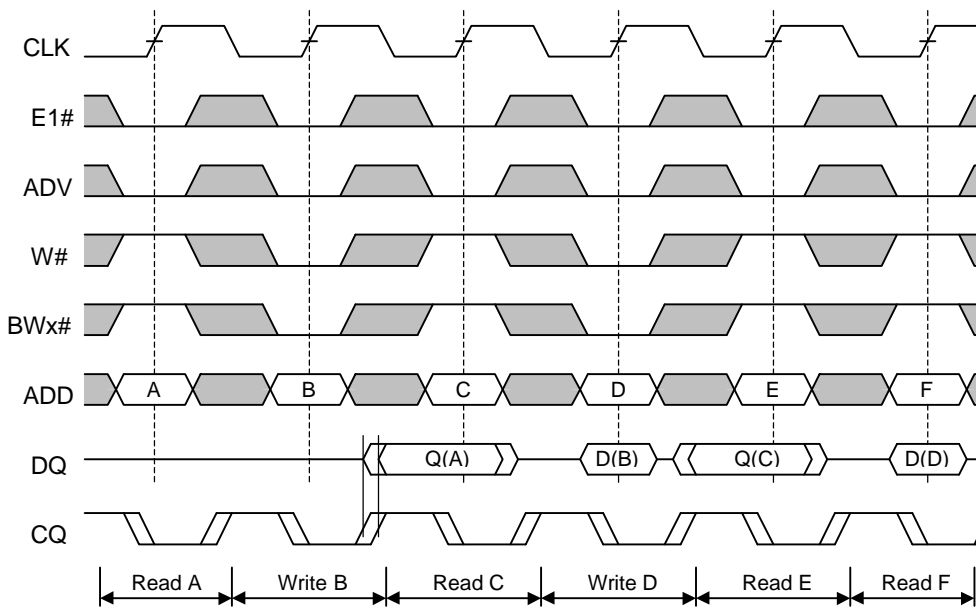

Special Function

Burst Cycles

The SRAM provides an on-chip burst address generator that can be utilized, if desired, to further simplify burst read or write implementations. The ADV control pin, when driven high, commands the SRAM to advance the internal address counter and use the counter generated address to read or write the SRAM. The starting address for the first cycle in a burst cycle series is loaded into the SRAM by driving the ADV pin low, into Load mode.

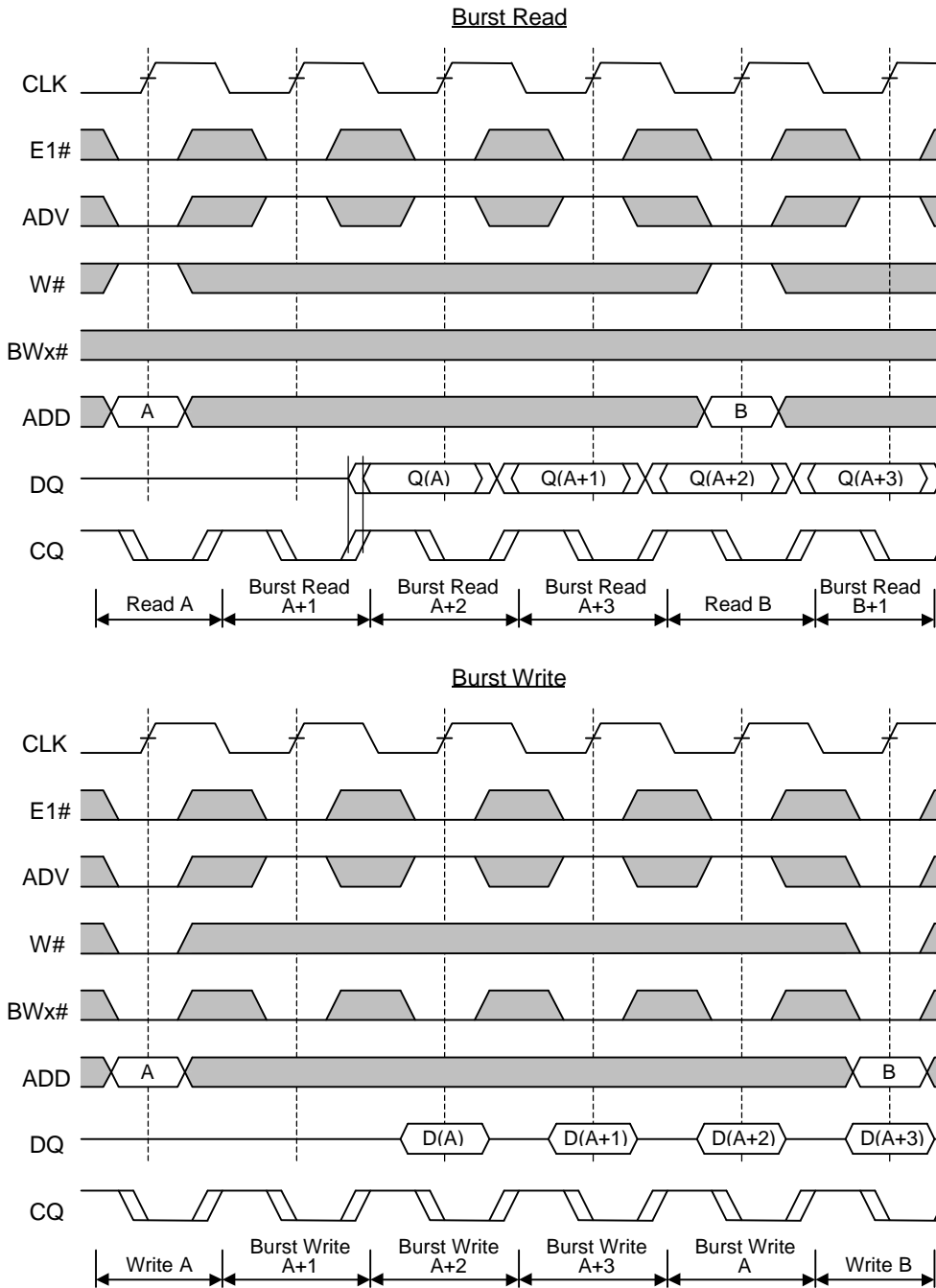

DC OPERATED TRUTH TABLE

Name	Input Status	Operation
LBO#	HIGH or NC	Interleaved Burst Sequence
	LOW	Linear Burst Sequence

Note5. LBO# is DC operated pin.

Note6. NC means No Connection.

Note7. See BURST SEQUENCE TABLE about interleaved and Linear Burst Sequence.

BURST SEQUENCE TABLE

(1) Interleaved Burst Sequence (when LBO# = HIGH or NC)

Operation	A18~A2	A1,A0			
First access, latch external address	A18~A2	0, 0	0, 1	1, 0	1, 1
Second access(first burst address)	latched A18~A2	0, 1	0, 0	1, 1	1, 0
Third access(second burst address)	latched A18~A2	1, 0	1, 1	0, 0	0, 1
Fourth access(third burst address)	latched A18~A2	1, 1	1, 0	0, 1	0, 0

(2) Linear Burst Sequence (when LBO# = LOW)

Operation	A18~A2	A1,A0			
First access, latch external address	A18~A2	0, 0	0, 1	1, 0	1, 1
Second access(first burst address)	latched A18~A2	0, 1	1, 0	1, 1	0, 0
Third access(second burst address)	latched A18~A2	1, 0	1, 1	0, 0	0, 1
Fourth access(third burst address)	latched A18~A2	1, 1	0, 0	0, 1	1, 0

Note8. The burst sequence wraps around to its initial state upon completion.



Echo Clock

The SRAM features Echo Clocks, CQ1,CQ2, CQ1#, and CQ2# that track the performance of the output drivers. The Echo Clocks are delayed copies of the main RAM clock, CLK. Echo Clocks are designed to track changes in output driver delays due to variance in die temperature and supply voltage. The Echo Clocks are designed to fire with the rest of the data output drivers. The SRAM provide both in-phase, or true, Echo Clock outputs (CQ1 and CQ2) and inverted Echo Clock outputs (CQ1# and CQ2#). It should be noted that deselection of the SRAM via E2 and E3 also deselected the Echo Clock output drivers. The deselection of Echo Clock drivers is always pipelined to the same degree as output data. Deselection of the SRAM via E1# does not deactivate the Echo Clocks.

Programmable Enable

The SRAM features two user programmable chip enable inputs, E2 and E3. The sense of the inputs, whether they function as active low or active high inputs, is determined by the state of the programming inputs, EP2 and EP3. For example, if EP2 is held at HIGH, E2 functions as an active high enable. If EP2 is held to LOW, E2 functions as an active low chip enable input.

Programmability of E2 and E3 allows for banks of depth expansion to be accomplished with no additional logic. By programming the enable inputs of four SRAMs in binary sequence (00,01,10,11) and driving the enable inputs with two address inputs, four SRAMs can be made to look like one larger SRAM to the system.

Example Four Bank Depth Schematic

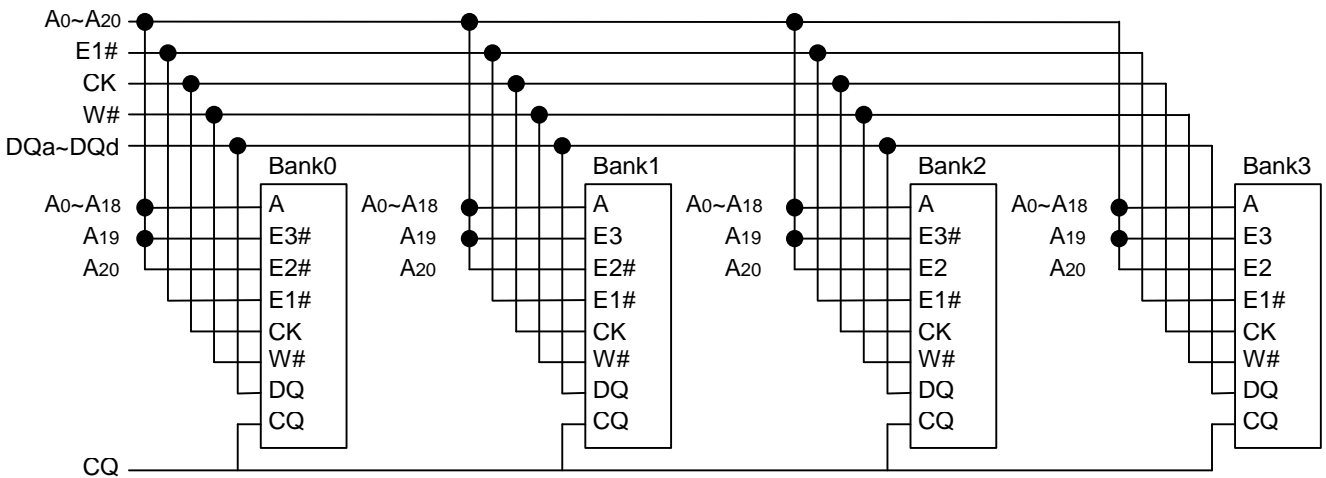

Bank Enable Truth Table

	EP2	EP3	E2	E3
Bank0	LOW	LOW	Active Low	Active Low
Bank1	LOW	HIGH	Active Low	Active High
Bank2	HIGH	LOW	Active High	Active Low
Bank3	HIGH	HIGH	Active High	Active High



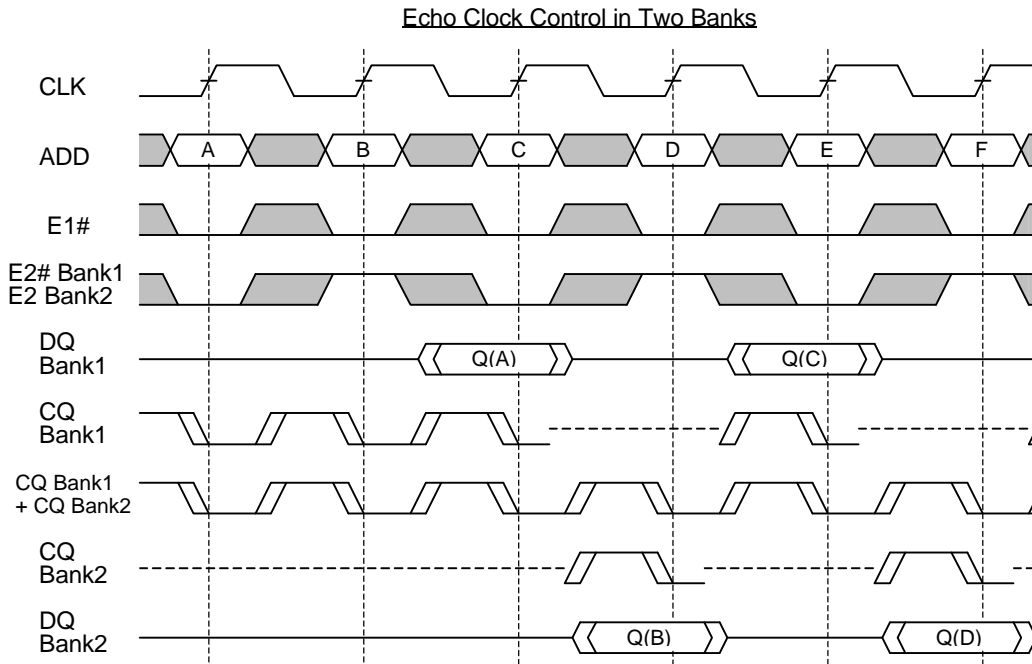

Note9. E1# does not deselect the Echo Clock Outputs. Echo Clock outputs are synchronously deselected by E2 or E3 being sampled false.

It should be noted that deselection of the SRAM via E2 and E3 also deselects the Echo Clock output drivers. The deselection of Echo Clock drivers is always pipelined to the same degree as output data. Deselection of the SRAM via E1# does not deactivate the Echo Clocks.

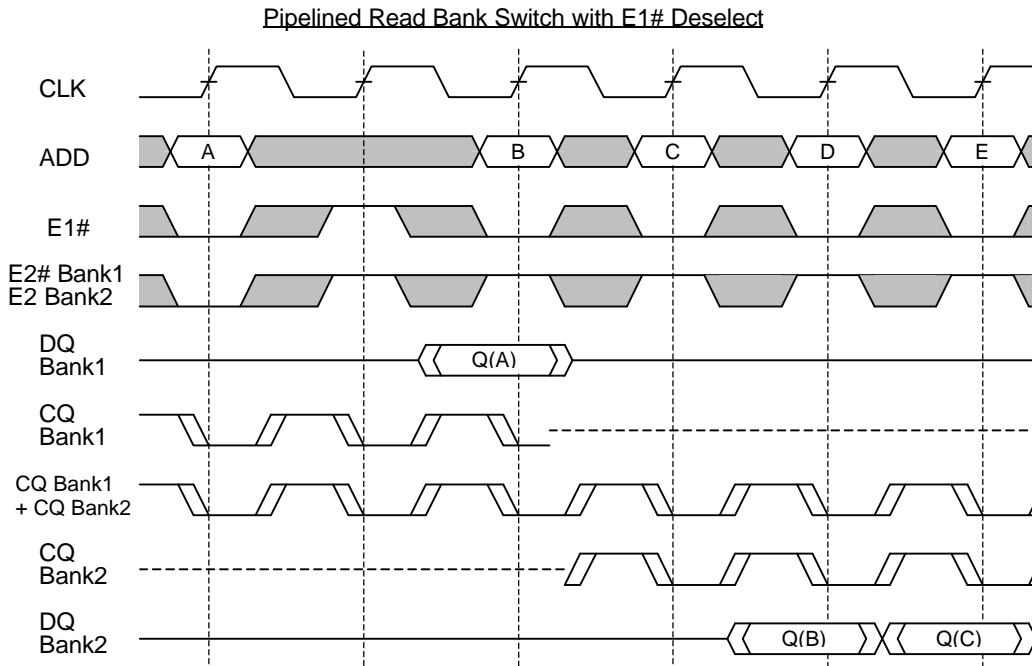

Note10. E1# does not deselect the Echo Clock Outputs. Echo Clock outputs are synchronously deselected by E2 or E3 being sampled false.

In some applications it may be appropriate to pause between banks; to deselect both SRAMs with E1# before resuming read operations. An E1# deselect at a bank switch will allow at least one clock to be issued from the new bank before the first read cycle in the bank. Although the following drawing illustrates a E1# read pause upon switching from Bank 1 to Bank 2, a write to Bank 2 would have the same effect, causing the SRAM in Bank 2 to issue at least one clock before it is needed.

Output Driver Impedance Control

The ZQ pin of SRAMs supplied with selectable impedance drivers, allows selection between SRAM nominal drive strength (ZQ low) for multi-drop bus applications and low drive strength (ZQ floating or high) point-to-point applications.



TRUTH TABLE

CLK	E1# (tn)	E (tn)	ADV (tn)	W# (tn)	BW# (tn)	Previous Operation	Current Operation	DQ/CQ (tn)	DQ/CQ (tn+1)	DQ/CQ (tn+2)
L->H	X	F	L	X	X	X	Bank Deselect	***	High-Z	---
L->H	X	X	H	X	X	Bank Deselect	Bank Deselect (Continue)	High-Z	High-Z	---
L->H	H	T	L	X	X	X	Deselect	***	High-Z / CQ	---
L->H	X	X	H	X	X	Deselect	Deselect (Continue)	High-Z / CQ	High-Z / CQ	---
L->H	L	T	L	L	T	X	Write Loads new address Stores DQx if BWx#=LOW	***	***	Dn / CQ (tn)
L->H	L	T	L	L	F	X	Write (Abort) Loads new address No data stored	***	***	High-Z / CQ
L->H	X	X	H	X	T	Write	Write Continue Increments address by 1 Stores DQx if BWx#=LOW	***	Dn-1 / CQ (tn-1)	Dn / CQ (tn)
L->H	X	X	H	X	F	Write	Write Continue (Abort) Increments address by 1 No data stored	***	Dn-1 / CQ (tn-1)	High-Z / CQ
L->H	L	T	L	H	X	X	Read Loads new address	***	Qn / CQ (tn)	---
L->H	X	X	H	X	X	Read	Read Continue Increments address by 1	Qn-1 / CQ (tn-1)	Qn / CQ (tn)	---

Note11. If E2=EP2 and E3=EP3 then E="T" else E="F".

Note12. If one or more BWx#=LOW then BW#="T" else BW#="F".

Note13. "H" = input "HIGH"; "L" = input "LOW"; "X" = input "don't care"; "T" = input "true"; "F" = input "false".

Note14. " *** " = indicates that the DQ input requirement / output state and CQ output state are determined by the previous operation.

Note15. " --- " = indicates that the DQ input requirement / output state and CQ output state are determined by the next operation.

Note16. DQs are tri-stated in response to Bank Deselect, Deselect and Write commands, one full cycle after the command is sampled.

Note17. CQs are tri-stated in response to Bank Deselect commands only, one full cycle after the command is sampled.

Note18. Up to three (3) Continue operations may be initiated after a Read or Write operation is initiated to burst transfer up to four (4) distinct pieces of data per single external address input. If a fourth (4) Continue operation is initiated, the internal address wraps back to the initial external (base) address.

WRITE TRUTH TABLE

W#	BWa#	BWb#	BWc#	BWd#	Function
H	X	X	X	X	Read
L	L	H	H	H	Write Byte "a"
L	H	L	H	H	Write Byte "b"
L	H	H	L	H	Write Byte "c"
L	H	H	H	L	Write Byte "d"
L	L	L	L	L	Write All Bytes
L	H	H	H	H	Write Abort / NOP

Note19. X means "don't care". H means logic HIGH. L means logic LOW.

Note20. All inputs must meet setup and hold times around the rising edge (LOW to HIGH) of CLK.



STATE DIAGRAM

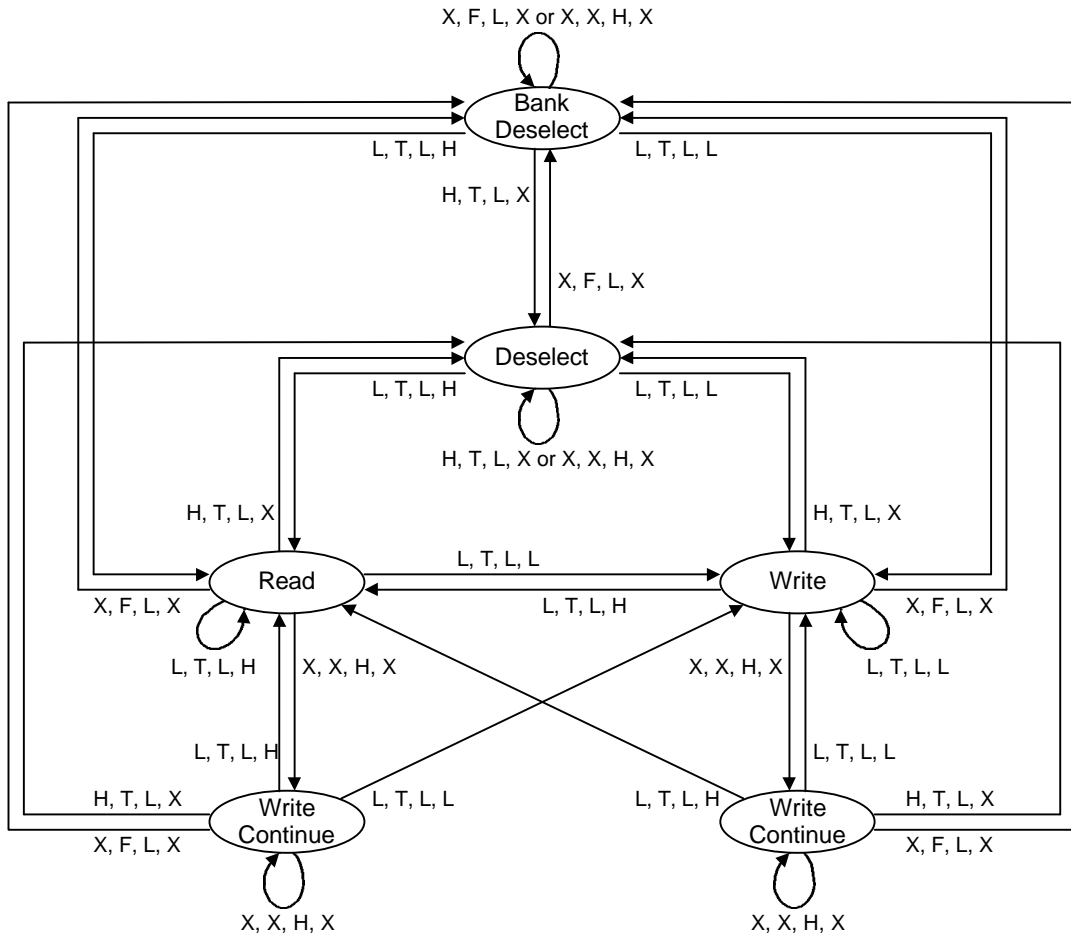

Key

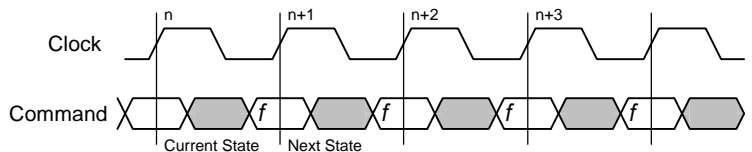
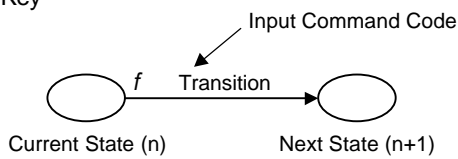

Current State & Next State Definition for Read/Write Control State Diagram

Note21. The notation "X, X, X, X" controlling the state transitions above indicate the states of inputs E1#, E, ADV, and W# respectively.

Note22. If (E2=EP2 and E3=EP3) then E="T" else E="F".

Note23. "H" = input "HIGH"; "L" = input "LOW"; "X" = input "don't care"; "T" = input "true"; "F" = input "false".



ABSOLUTE MAXIMUM RATINGS

Symbol	Parameter	Conditions	Ratings	Unit
V _{DD}	Power Supply Voltage	With respect to V _{SS}	-0.5*~2.5	V
V _{DDQ}	I/O Buffer Power Supply Voltage		-0.5*~2.5	V
V _I	Input Voltage		-0.5~V _{DDQ} +0.5(≤2.5V max.) **	V
V _O	Output Voltage		-0.5~V _{DDQ} +0.5(≤2.5V max.) **	V
PD	Maximum Power Dissipation (V _{DD})		780	mW
T _{OPR}	Operating Temperature		0~70	°C
T _{STG(bias)}	Storage Temperature(bias)		-10~85	°C
T _{STG}	Storage Temperature		-65~150	°C

Note24. * This is -1.0V~3.6V when pulse width≤2ns, and -0.5V~2.5V in case of DC.

** This is -1.0V~V_{DDQ}+1.0V(≤3.6V max.) when pulse width≤2ns, and -0.5V~V_{DDQ}+0.5V in case of DC.

DC ELECTRICAL CHARACTERISTICS

(1) Power Supplies

Symbol	Parameter	Condition	Limits		Unit
			Min	Max	
V _{DD}	Power Supply Voltage		1.70	1.95	V
V _{DDQ}	I/O Buffer Power Supply Voltage		1.70	1.95	V

(2) CMOS I/O DC Input Characteristics

Symbol	Parameter	Condition	Limits		Unit
			Min	Max	
V _{IH}	High-level Input Voltage		0.65*V _{DDQ}	V _{DDQ} +0.3	V
V _{IL}	Low-level Input Voltage		-0.3*	0.35*V _{DDQ}	V

Note25. *V_{IL} min is -1.0V and V_{IH} max is V_{DDQ}+1.0V(max. 3.6V) in case of AC (Pulse width ≤ 2ns).

(3) Input and Output Leakage Characteristics

Symbol	Parameter	Condition	Limits		Unit
			Min	Max	
I _{IL}	Input Leakage Current (except EP2, EP3, LBO#, ZQ, MCH, MCL pins)	V _I = 0V~V _{DDQ}		10	μA
	Input Leakage Current of EP2, EP3, LBO#, ZQ, MCH, MCL pins	V _I = 0V~V _{DDQ}		10	μA
I _{OL}	Output Leakage Current	V _{I/O} = 0V~V _{DDQ}		10	μA

(4) Selectable Impedance Output Driver DC Electrical Characteristics

Symbol	Parameter	Condition	Limits		Unit
			Min	Max	
VOHL	Low Drive Output High Voltage	IOHL = -4mA	VDDQ-0.4V		V
VOLL	Low Drive Output Low Voltage	IOLL = 4mA		0.4	V
VOHH	High Drive Output High Voltage	IOHH = -8mA	VDDQ-0.4V		V
VOLH	High Drive Output Low Voltage	IOLH = 8mA		0.4	V

Note26. ZQ=H; High Impedance output driver setting
 Note27. ZQ=L; Low Impedance output driver setting

(5) Operating Currents

Symbol	Parameter	Condition	Limits		Unit	
			Min	Max		
ICC1	Power Supply Current : Operating	Device selected; Output open All other inputs $V_i \leq V_{iL}$ or $V_i \geq V_{iH}$	4.0ns cycle (250MHz)		400	mA
			4.4ns cycle (225MHz)		380	
			5.0ns cycle (200MHz)		360	
ICC2	Power Supply Current :Chip Disable and Bank Deselect	E1# $\geq V_{iH}$ or (E2 or E3 False) Output open All other inputs $V_i \leq V_{iL}$ or $V_i \geq V_{iH}$	4.0ns cycle (250MHz)		140	mA
			4.4ns cycle (225MHz)		110	
			5.0ns cycle (200MHz)		100	
ICC3	CMOS Standby Current (CLK stopped standby mode)	Device deselected; Output open CLK frequency=0Hz All inputs $V_i \leq V_{ss}+0.1V$ or $V_i \geq V_{DDQ}-0.1V$			20	mA

CAPACITANCE

Symbol	Parameter	Condition	Limits			Unit
			Min	Typ	Max	
CI	Input Capacitance	$V_i = GND$, $V_i = 25mV_{rms}$, $f = 1MHz$			6	pF
Co	Input / Output (DQ) Capacitance	$V_o = GND$, $V_o = 25mV_{rms}$, $f = 1MHz$			8	pF

Note28. This parameter is sampled.

THERMAL RESISTANCE

Symbol	Parameter	Condition	Limits			Unit
			Min	Typ	Max	
θ_{JA}	Thermal resistance Junction Ambient	TBD		TBD		pF
θ_{JC}	Thermal resistance Junction to Case	TBD		TBD		pF



AC ELECTRICAL CHARACTERISTICS ($T_a=0\sim 70^\circ\text{C}$, $V_{DD}=1.70\sim 1.95\text{V}$, unless otherwise noted)

(1) MEASUREMENT CONDITION

- Input pulse levels $V_{IH}=V_{DDQ}$, $V_{IL}=0\text{V}$
- Input rise and fall times faster than or equal to 1V/ns
- Input timing reference levels $V_{IH}=V_{IL}=V_{DDQ}/2$
- Output reference levels $V_{IH}=V_{IL}=V_{DDQ}/2$
- Output load Fig.1

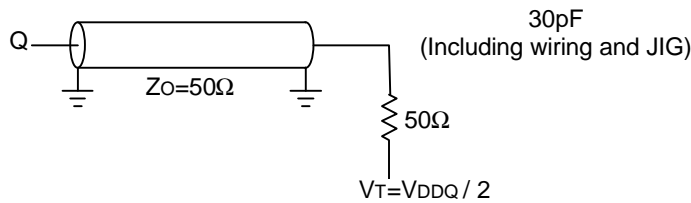

Fig.1 Output load

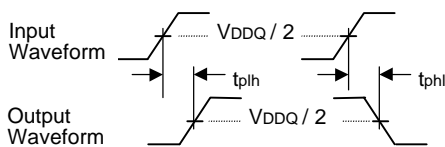

Fig.2 Tdly measurement

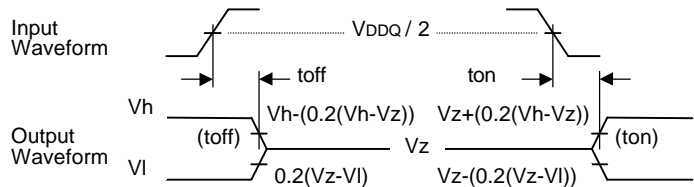

Fig.3 Tri-State measurement

Note29. Valid Delay Measurement is made from the $V_{DDQ}/2$ on the input waveform to the $V_{DDQ}/2$ on the output waveform.

Input waveform should have a slew rate of faster than or equal to 1V/ns .

Note30. Tri-state toff measurement is made from the $V_{DDQ}/2$ on the input waveform to the output waveform moving 20% from its initial to final Value $V_{DDQ}/2$.

Note: the initial value is not V_{OL} or V_{OH} as specified in DC ELECTRICAL CHARACTERISTICS table.

Note31. Tri-state ton measurement is made from the $V_{DDQ}/2$ on the input waveform to the output waveform moving 20% from its initial Value $V_{DDQ}/2$ to its final Value.

Note: the final value is not V_{OL} or V_{OH} as specified in DC ELECTRICAL CHARACTERISTICS table.

Note32. Clocks, Data, Address and control signals will be tested with a minimum input slew rate of faster than or equal to 1V/ns .



(2)TIMING CHARACTERISTICS

Symbol	Parameter	Limits						Unit
		250MHz		225MHz		200MHz		
		-25		-22		-20		
		Min	Max	Min	Max	Min	Max	
Clock								
tKHKH	Clock Cycle Time	4.0		4.4		5.0		ns
tKHKL	Clock HIGH Time	1.5		1.6		1.8		ns
tKLKH	Clock LOW Time	1.5		1.6		1.8		ns
Output times								
tKHQV	Clock HIGH to Output Valid		2.6		2.8		3.2	ns
tKHQX	Clock HIGH to Output Invalid	0.5		0.6		0.7		ns
tKHQX1	Clock HIGH to Output in Low-Z	0.5		0.6		0.7		ns
tKHQZ	Clock HIGH to Output in High-Z	0.5	2.6	0.6	2.8	0.7	3.2	ns
tCHCL	Echo Clock HIGH Time	1.25		1.35		1.55		ns
tCLCH	Echo Clock LOW Time	1.25		1.35		1.55		ns
tKHCH	Clock HIGH to Echo Clock HIGH	0.5	2.5	0.5	2.7	0.5	3.1	ns
tKLCL	Clock LOW to Echo Clock LOW	0.5	2.5	0.5	2.7	0.5	3.1	ns
tKHCX1	Clock HIGH to Echo Clock Low-Z	0.5		0.5		0.5		ns
tKHCZ	Clock HIGH to Echo Clock High-Z	0.5	2.5	0.5	2.7	0.5	3.1	ns
tCHQV	Echo Clock HIGH to Output Valid		0.5		0.5		0.5	ns
tCHQX	Output Invalid to Echo Clock HIGH		-0.5		-0.5		-0.5	ns
Setup Times								
tAVKH	Address Valid to Clock HIGH	0.8		1.0		1.2		ns
tadvVKH	ADV Valid to Clock HIGH	0.8		1.0		1.2		ns
tWVKH	Write Valid to Clock HIGH	0.8		1.0		1.2		ns
tBxVKH	Byte Write Valid to Clock HIGH (BWA#~BWD#)	0.8		1.0		1.2		ns
tEVKH	Enable Valid to Clock HIGH (E1#,E2,E3)	0.8		1.0		1.2		ns
tDVKH	Data In Valid Clock HIGH	0.8		1.0		1.2		ns
Hold Times								
tKHAX	Clock HIGH to Address don't care	0.5		0.5		0.5		ns
tKHadvX	Clock HIGH to ADV don't care	0.5		0.5		0.5		ns
tKHwx	Clock HIGH to Write don't care	0.5		0.5		0.5		ns
tKHBxX	Clock HIGH to Byte Write don't care (BWA#~BWD#)	0.5		0.5		0.5		ns
tKHEx	Clock HIGH to Enable don't care (E1#,E2,E3)	0.5		0.5		0.5		ns
tKHDX	Clock HIGH to Data In don't care	0.5		0.5		0.5		ns

Note33. Test conditions is specified with the output loading shown in Fig.1 unless otherwise noted.

Note34. tKHQX1, tKHQZ, tKHCX1, tKHCZ are sampled.

Note35. LBO#, EP2, EP3, ZQ is static and must not change during normal operation.



Timing Parameter Key

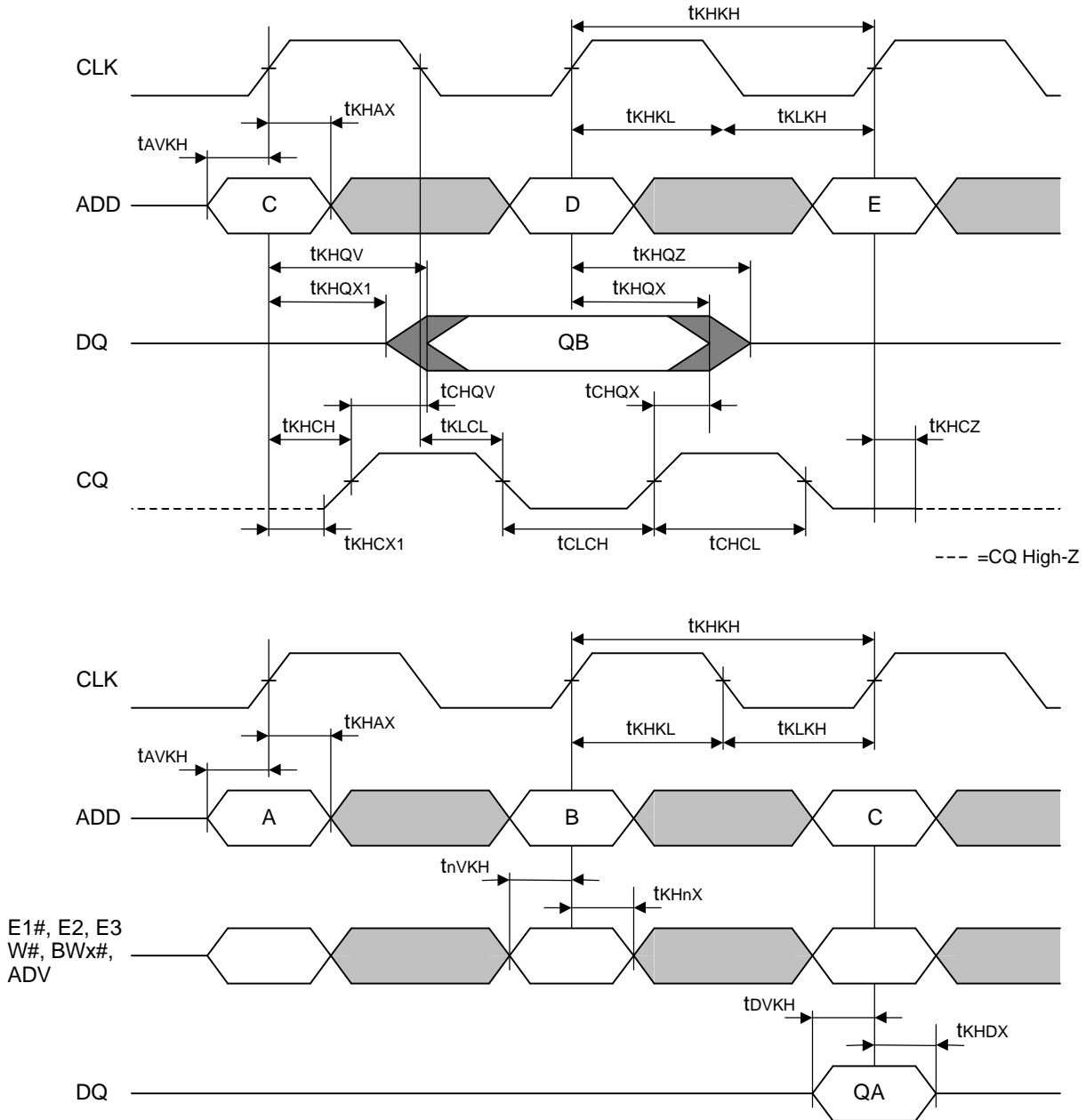

Note36. $t_{nVKH}=t_{EVKH}$, t_{wVKH} , t_{BxVKH} , t_{advVKH} , etc. and $t_{KHnX}=t_{KHEx}$, t_{KHwX} , t_{KHbXx} , t_{KHadvX} , etc.



JTAG PORT OPERATION

Overview

The JTAG Port on this SRAM operates in a manner consistent with IEEE Standard 1149.1-1990, a serial boundary scan interface standard (commonly referred to as JTAG), but does not implement all of the function required for 1149.1 compliance. Unlike JTAG implementations that have been common among SRAM vendors for the last several years, this implementation does offer a form of EXTEST, known as Clock Assisted EXTEST, reducing or eliminating the "hand coding" that has been required to overcome the test program compiler errors caused by previous non-compliant implementation. The JTAG Port interfaces with conventional CMOS logic level signaling.

Disabling the JTAG port

It is possible to use this device without utilizing the JTAG port. The port is reset at power-up and will remain inactive unless clocked. To assure normal operation of the SRAM with the JTAG Port unused, the TCK, TDI and TMS pins may be left floating or tied to High. The TDO pin should be left unconnected.

JTAG Pin Description

Test Clock (TCK)

The TCK input is clock for all TAP events. All inputs are captured on the rising edge of TCK and the Test Data Out (TDO) propagates from the falling edge of TCK.

Test Mode Select (TMS)

The TMS input is sampled on the rising edge of TCK. This is the command input for the TAP Controller state machine. An undriven TMS input will produce the same result as a logic one input level.

Test Data In (TDI)

The TDI input is sampled on the rising edge of TCK. This is the input side of the serial registers placed between the TDI and TDO pins. The register placed between the TDI and TDO pins is determined by the state of the TAP Controller state machine and the instruction that is currently loaded in the TAP Instruction Register (refer to the TAP Controller State Diagram). An undriven TDI Input will produce the same result as a logic one input level.

Test Data Out (TDO)

The TDO output is active depending on the state of the TAP Controller state machine. Output changes in response to the falling edge of TCK. This is the output side of the serial registers placed between the TDI and TDO pins.

Note:

This device does not have a TRST (TAP Reset) pin. TRST is optional in IEEE 1149.1. The Test-Logic-Reset state is entered while TMS is held high for five rising edges of TCK. The TAP Controller is also reset automatically at power-up.

JTAG Port Registers

Overview

The various JTAG registers, referred to as Test Access Port or TAP Registers, are selected (one at a time) via the sequence of 1s and 0s applied to TMS as TCK is strobed. Each of TAP Registers are serial shift registers that capture serial input data on the rising edge of TCK and push serial data out on the next falling edge of TCK. When a register is selected, it is placed between the TDI and TDO pins.

Instruction Register

The Instruction Register holds the instructions that are executed by the TAP Controller when it is moved into the Run-Test/Idle, or the

various data register states. Instructions are 3 bits long. The Instruction Register can be loaded when it is placed between the TDI and TDO pins. The Instruction Register is automatically preloaded with the IDCODE instruction at power-up or whenever the controller is placed in the Test-Logic-Reset state.

Bypass Register

The Bypass register is a single-bit register that can be placed between the TDI and TDO pins. It allows serial test data to be passed through the SRAM's JTAG Port to another device in the scan chain with as little delay as possible.

Boundary Scan Register

The Boundary Scan Register is a collection of flip flops that can be preset by the logic level found on the SRAM's input or I/O pins. The flip flops are then daisy chained together so the levels found can be shifted serially out of the JTAG Port's TDO pins. The Boundary Scan Register also includes a number of place holder flip flops (always set to a logic 1). The relationship between the device pins and the bits in the Boundary Scan Register is described in the Scan Order Table following. The Boundary Scan Register, under the control of the TAP Controller, is loaded with the contents of the SRAM's I/O ring when the controller is in the Capture-RD state and then is placed between the TDI and TDO pins when the controller is moved to the Shift-DR state. SAMPLE-Z, SAMPLE/PRELOAD and EXTEST instruction can be used to activate the Boundary Scan Register.

Identification (ID) Register

The ID register is a 32-bit register that is loaded with a device and vendor specific 32-bit code when the controllers put in the Capture-DR state with the IDCODE instruction loaded in the Instruction Register. The code is loaded from 32-bit on-chip ROM. It describes various attributes of the SRAM (see page 25). The register is then placed between the TDI and TDO pins when the controller is moved into the Shift-DR state. Bit 0 in the register is the LSB and the first to reach the TDO pin when shifting begins.

TAP Controller Instruction Set

Overview

There are two classes of instructions defined in the Standard 1149.1-1990; standard (Public) instructions, and device specific (Private) instructions. Some Public instructions are mandatory for 1149.1 compliance. Optional Public instructions must be implemented in prescribed ways. Although the TAP Controller in this device follows the 1149.1 conventions, it is not 1194.1-compliant because one of the mandatory instructions, EXTEST, is uniquely implemented. The TAP on this device may be used to monitor all input and I/O pads. This device will not perform INTEST but can perform the preload portion of the SAMPLE/PRELOAD command.

When the TAP controller is placed in the Capture-IR state, the two least significant bits of the instruction register are loaded with 01. When the TAP controller is moved to the Shift-IR state, the Instruction Register is placed between the TDI and TDO pins. In this state the desired instruction is serially loaded through the TDI input (while the previous contents are shifted out at the TDO output). For all instructions, the TAP executes newly loaded instructions only when the controller is moved to the Update-IR state. The TAP Instruction Set for this device is listed in the following table.

Instruction Descriptions

BYPASS

When the BYPASS instruction is loaded in the Instruction Register, the Bypass Register is placed between the TDI and TDO pins. This occurs when the TAP Controller is moved to the Shift-DR state. This allows the board level scan path to be shortened to facilitate testing of other devices in the scan path.

SAMPLE/PRELOAD

SAMPLE/PRELOAD is a Standard 1149.1 mandatory public instruction. When the SAMPLE/PRELOAD instruction is loaded in the Instruction Register, moving the TAP Controller into the Capture-DR state loads the data in the SRAM's input and I/O buffers into the Boundary Scan Register. Some Boundary Scan Register locations are not associated with an input or I/O pin, and are loaded with the default state identified in the BSDL file. Because the SRAM clock is independent from the TAP Clock (TCK) it is possible for the TAP to attempt to capture the I/O ring contents while the input buffers are in transition (i.e. in a metastable state). Although allowing the TAP to

sample metastable inputs will not harm the device, repeatable results cannot be expected. SRAM input signals must be stabilized for long enough to meet the TAP's input data capture set-up plus hold time (t_{TS} plus t_{TH}). The SRAM's clock inputs need not be paused for any other TAP operation except capturing the I/O ring contents into the Boundary Scan Register. Moving the controller to the Shift-DR state then places the Boundary Scan Register between the TDI and TDO pins.

EXTEST-A

EXTEST is an IEEE 1149.1 mandatory public instruction. It is to be executed whenever the Instruction Register is loaded with all logic 0s. The EXTEST command does not block or override the SRAM's input pins; therefore, the SRAM's internal state is still determined by its input pins.

Typically, the Boundary Scan Register is loaded with the desired pattern with the SAMPLE/PRELOAD command. Then the EXTEST command is used to output the Boundary Scan Register's contents, in parallel, on the SRAM's data output drivers on the falling edge of TCK when the controller is in the Update-IR state.

Alternately, the Boundary Scan Register may be loaded in parallel using the EXTEST command. When the EXTEST instruction is selected, the state of all SRAM's input and I/O pins, as well as the default values at Scan Register locations not associated with a pin, are transferred in parallel into the Boundary Scan Register on the rising edge of TCK in the Capture-DR state, the SRAM's output pins drive out the value of the Boundary Scan Register location with which each output pin is associated.

The EXTEST implementation in this device does not, without further user intervention, actually move the contents of the scan chain onto the SRAM's output pins. Therefore this device is not strictly 1149.1-compliant. To push data from the Boundary Scan Registers, in parallel, out onto the SRAM's I/O and output pins, the SRAM's main clock (CK) must be pulsed. A single CK transition is sufficient to transfer the data, but more transitions will do no harm.

IDCODE

The IDCODE instruction causes the ID ROM to be loaded into the ID register when the controller is in the Capture-DR state and places the ID Register between the TDI and TDO pins in the Shift-DR state. The IDCODE instruction is the default instruction loaded in at power-up and any time the controller is placed in the Test-Logic-Reset state.

SAMPLE-Z

If the SAMPLE-Z instruction is loaded in the Instruction Register, all SRAM outputs are forced to an inactive drive state (High-Z) and the Boundary Scan Register is placed between the TDI and TDO pins when the TAP Controller is moved to the Shift-DR state.

RFU

These instructions are reserved for future use. Do not use these instructions.

JTAG TAP BLOCK DIAGRAM

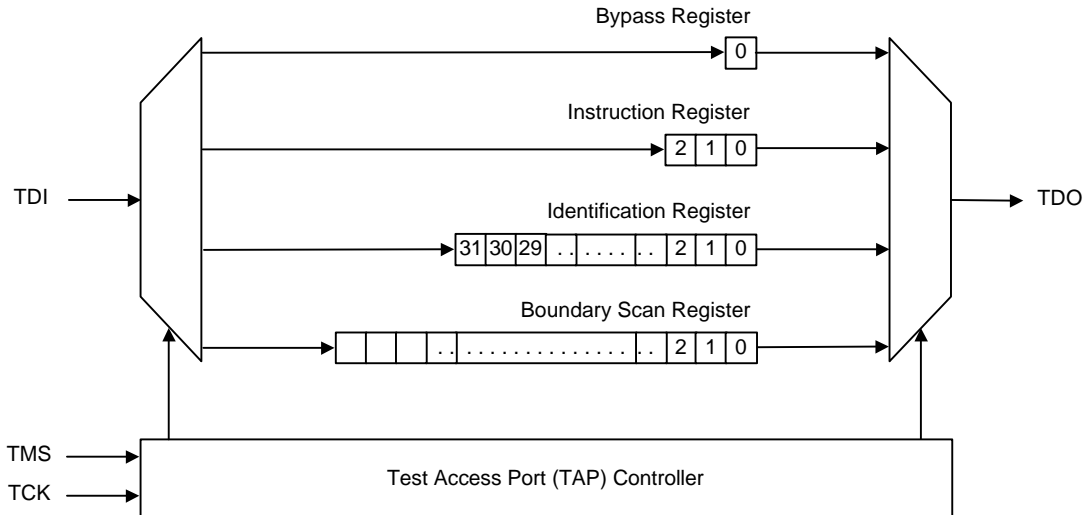

BOUNDARY SCAN ORDER

TBD



JTAG TAP CONTROLLER STATE DIAGRAM

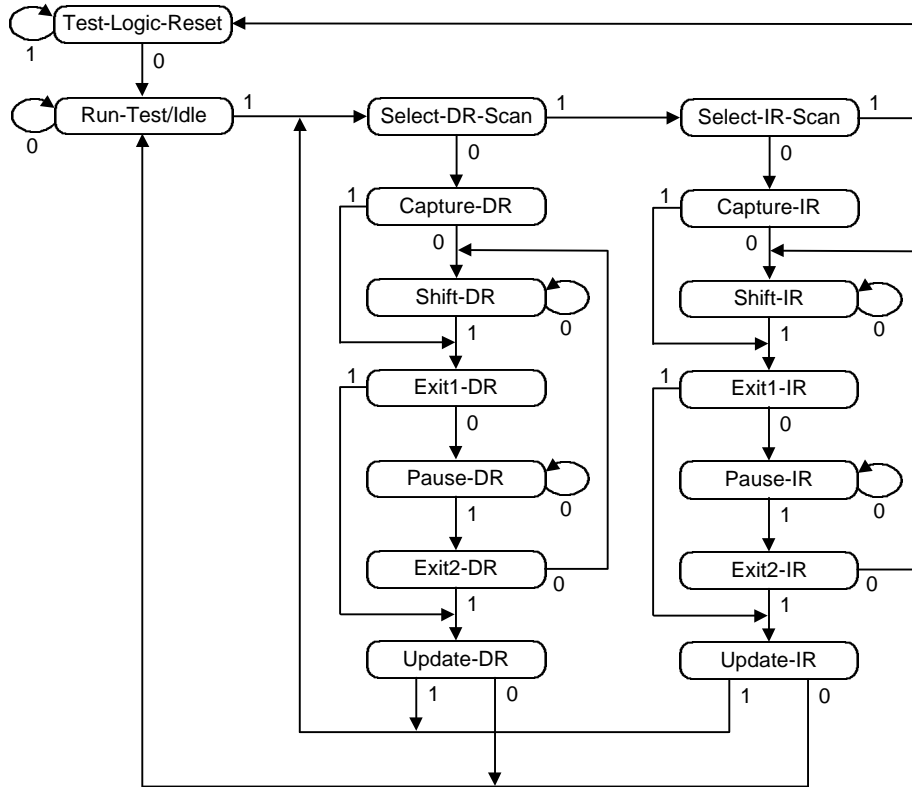

TAP CONTROLLER DC ELECTRICAL CHARACTERISTICS (Ta=0~70°C, VDD=1.70~1.95V, unless otherwise noted)

Symbol	Parameter	Condition	Limits		Unit
			Min	Max	
VIHT	Test Port Input High Voltage		0.65*VDDQ	VDDQ+0.3 **	V
VILT	Test Port Input Low Voltage		-0.3 **	0.35*VDDQ	V
VOHT	Test Port Output High Voltage	IOH=-100µA	VDDQ-0.1	-	V
VOLT	Test Port Output Low Voltage	IOL=+100µA	-	0.1	V
IINT	TMS, TCK and TDI Input Leakage Current		-10	10	µA
IOLT	TDO Output Leakage Current	Output Disable, VOUT=0V~VDDQ	-10	10	µA

Note37. **Input Undershoot/Overshoot voltage must be $-1.0V < V_i < V_{DDQ} + 1V$ (max. 3.6V) with a pulse width not to exceed 20% tTCK.



TAP CONTROLLER AC ELECTRICAL CHARACTERISTICS ($T_a=0\sim 70^\circ\text{C}$, $V_{DD}=1.70\sim 1.95\text{V}$, unless otherwise noted)

(1) MEASUREMENT CONDITION

- Input pulse levels $V_{IH}=V_{DDQ}$, $V_{IL}=0\text{V}$
- Input rise and fall times faster than or equal to 1V/ns
- Input timing reference levels $V_{IH}=V_{IL}=V_{DDQ}/2$
- Output reference levels $V_{IH}=V_{IL}=V_{DDQ}/2$
- Output load Fig.4

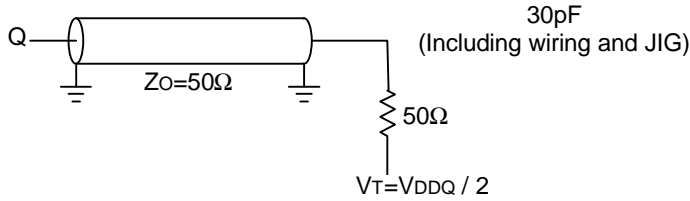
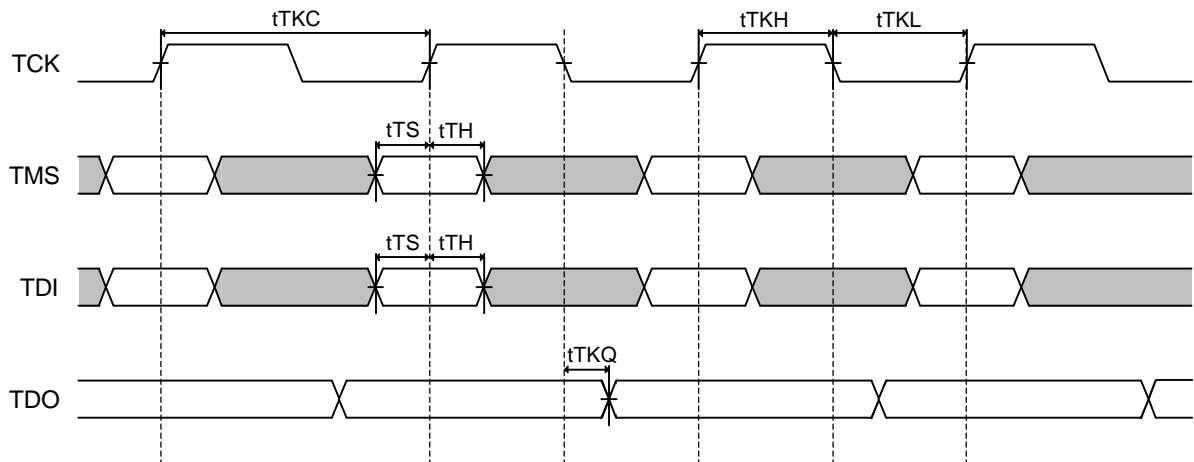

Fig.4 Output load

(2) TIMING CHARACTERISTICS

Symbol	Parameter	Limits		Unit
		Min	Max	
tTF	TCK Frequency		20	MHz
tTKC	TCK Cycle Time	50		ns
tTKH	TCK High Pulse Width	20		ns
tTKL	TCK Low Pulse Width	20		ns
tTS	TDI, TMS setup time	10		ns
tTH	TDI, TMS hold time	10		ns
tTKQ	TCK Low to TDO valid		20	ns

(3) TIMING



JTAG TAP INSTRUCTION SET SUMMARY

Instruction	Code	Description
EXTEST-A	000	Captures I/O ring contents. Places the Boundary Scan Register between TDI and TDO. This SRAM implements an Clock Assisted EXTEST function. Not 1149.1 Compliant.
IDCODE	001	Preloads ID Register and places it between TDI and TDO
SAMPLE-Z	010	Captures I/O ring contents. Places the Boundary Scan Register between TDI and TDO. Forces all Data and Clock output drivers to High-Z
RFU	011	Do not use this instruction; Reserved for Future Use.
SAMPLE/PRELOAD	100	Captures I/O ring contents. Places the Boundary Scan Register between TDI and TDO.
RFU	101	Do not use this instruction; Reserved for Future Use.
RFU	110	Do not use this instruction; Reserved for Future Use.
BYPASS	111	Places the BYPASS Register between TDI and TDO.

STRUCTURE OF IDENTIFICATION REGISTER

Bit No.	Revision		Device Information														JEDEC Vendor Code of MITSUBISHI																				
	31	30	VDD		Capacity				Function				Width				Gen.		11	10	9	8	7	6	5	4	3	2	1	0							
M5M5Y5636	0	0	0	0	0	0	1	0	0	1	0	1	0	1	0	0	0	1	1	0	0	0	0	0	0	0	0	0	0	0	0	1	1	1	0	0	1
	MSB																	LSB																			

Note38. Bit of Device Information "Gen.(Generation)" means

Bit No.	13	12
1 st Generation	0	0
2 nd Generation	0	1
3 rd Generation	1	0

Note39. Bit of Device Information "Width" means

Bit No.	16	15	14
X16	0	0	0
X18	0	0	1
X32	0	1	0
X36	0	1	1
X64	1	0	0
X72	1	0	1

Note40. Bit of Device Information "Function" means

Bit No.	20	19	18	17
Network SRAM	0	1	0	0
PB	0	0	0	1

Note41. Bit of Device Information "Capacity" means

Bit No.	24	23	22	21
1M or 1.15M	0	0	0	1
2M or 2.3M	0	0	1	0
4M or 4.5M	0	0	1	1
8M or 9M	0	1	0	0
16M or 18M	0	1	0	1
32M or 36M	0	1	1	0

Note42. Bit of Device Information "VDD" means

Bit No.	27	26	25
3.3V	0	0	0
2.5V	0	0	1
1.8V	0	1	0
1.5V	0	1	1



PACKAGE OUTLINE

209(11x19) bump Ball Grid Array(BGA) Pin Pitch 1.0mm

Refer to JEDEC Standard MS-028, Variation BC,
which can be seen at:

<http://www.jedec.org/download/search/MS-028C.pdf>



REVISION HISTORY

- Jun/06/2001 REV.0.0 First revision

