

8/16-bit Data Bus Flash ATA PC Card

Connector Type

Two- piece 68-pin

MF007M5-03ATxx
MF0015M-03ATxx
MF0030M-03ATxx
MF0045M-03ATxx
MF0060M-03ATxx
MF0075M-03ATxx
MF0090M-03ATxx
MF0105M-03ATxx

DESCRIPTION

Mitsubishi's Flash ATA cards provide large memory capacities on a device approximately the size of a credit card (85.6mm×54mm×3.3mm). The cards use a 8/16 bit data bus.

Available in 7.5MB, 15MB, 30MB, 45MB, 60MB, 75MB, 90MB and 105MB capacities, Mitsubishi's Flash ATA cards conform to the JEIDA/PCMCIA standard.

In default mode, the ATA card operates in PC Card compliant sockets. It conforms to PCMCIA2.1, JEIDA4.2 and PC Card Standard.

When the OE# signal is asserted low level by the Host system in power on cycle, the Mitsubishi's Flash ATA cards can be selected in a IDE ATA interface. It uses the ATA command set so no software drivers are required.

FEATURES

- 68 pin PC Card Standard Type-I PC Card
- Single 5V or 3.3V Supply
- Card density of up to 105MB maximum
- Four PC Card ATA and IDE ATA modes
- Nonvolatile, No Batteries Required
- High reliability based on internal ECC function
- Auto power-down mode

APPLICATIONS

- | | |
|----------------------|---------------------|
| ■ Computers | ■ Office automation |
| ■ Digital Camera | ■ Industrial |
| ■ Data Communication | ■ Consumer |

ATA PC CARDS

PRODUCT LIST

	Memory capacity(Bytes)	Data Bus width(bits)	Memory	Cylinder	Head	Sector
MF007M5-03ATxx	7,864,320	8/16	64Mbit Flash x 1	240	2	32
MF0015M-03ATxx	15,728,640		64Mbit Flash x 2	480	2	32
MF0030M-03ATxx	31,457,280		64Mbit Flash x 4	480	4	32
MF0045M-03ATxx	47,185,920		64Mbit Flash x 6	720	4	32
MF0060M-03ATxx	62,914,560		64Mbit Flash x 8	960	4	32
MF0075M-03ATxx	78,643,200		64Mbit Flash x 10	600	8	32
MF0090M-03ATxx	94,371,840		64Mbit Flash x 12	720	8	32
MF0105M-03ATxx	110,100,480		64Mbit Flash x 14	840	8	32

PIN ASSIGNMENT

Pin	PC Card Memory Mode		PC Card I/O Mode		IDE ATA Interface	
	Signal	I/O	Signal	I/O	Signal	I/O
1	GND	-	GND	-	GND	-
2	D3	I/O	D3	I/O	D3	I/O
3	D4	I/O	D4	I/O	D4	I/O
4	D5	I/O	D5	I/O	D5	I/O
5	D6	I/O	D6	I/O	D6	I/O
6	D7	I/O	D7	I/O	D7	I/O
7	CE1#	I	CE1#	I	CS0#	I
8	A10	I	A10	I	N.U	-
9	OE#	I	OE#	I	ATA SEL#	I
10	N.C	-	N.C	-	N.C	-
11	A9	I	A9	I	N.U	-
12	A8	I	A8	I	N.U	-
13	N.C	-	N.C	-	N.C	-
14	N.C	-	N.C	-	N.C	-
15	WE#	I	WE#	I	WE#	I
16	READY	O	IREQ#	O	INTRQ	O
17	Vcc	-	Vcc	-	Vcc	-
18	N.C	-	N.C	-	N.C	-
19	N.C	-	N.C	-	N.C	-
20	N.C	-	N.C	-	N.C	-
21	N.C	-	N.C	-	N.C	-
22	A7	I	A7	I	N.U	-
23	A6	I	A6	I	N.U	-
24	A5	I	A5	I	N.U	-
25	A4	I	A4	I	N.U	-
26	A3	I	A3	I	N.U	-
27	A2	I	A2	I	A2	I
28	A1	I	A1	I	A1	I
29	A0	I	A0	I	A0	I
30	D0	I/O	D0	I/O	D0	I/O
31	D1	I/O	D1	I/O	D1	I/O
32	D2	I/O	D2	I/O	D2	I/O
33	WP	O	IOIS16#	O	IOCS16#	O
34	GND	-	GND	-	GND	-

Pin	PC Card Memory Mode		PC Card I/O Mode		IDE ATA Interface	
	Signal	I/O	Signal	I/O	Signal	I/O
35	GND	-	GND	-	GND	-
36	CD1#	O	CD1#	O	CD1#	O
37	D11	I/O	D11	I/O	D11	I/O
38	D12	I/O	D12	I/O	D12	I/O
39	D13	I/O	D13	I/O	D13	I/O
40	D14	I/O	D14	I/O	D14	I/O
41	D15	I/O	D15	I/O	D15	I/O
42	CE2#	I	CE2#	I	CS1#	I
43	VS1#	O	VS1#	O	VS1#	O
44	N.U	-	IORD#	I	IORD#	I
45	N.U	-	IOWR#	I	IOWR#	I
46	N.C	-	N.C	-	N.C	-
47	N.C	-	N.C	-	N.C	-
48	N.C	-	N.C	-	N.C	-
49	N.C	-	N.C	-	N.C	-
50	N.C	-	N.C	-	N.C	-
51	Vcc	-	Vcc	-	Vcc	-
52	N.C	-	N.C	-	N.C	-
53	N.C	-	N.C	-	N.C	-
54	N.C	-	N.C	-	N.C	-
55	N.C	-	N.C	-	N.C	-
56	CSEL	I	CSEL	I	CSEL	I
57	VS2#	O	VS2#	O	VS2#	O
58	RESET	I	RESET	I	RESET#	I
59	WAIT#	O	WAIT#	O	IORDY	O
60	N.U	-	INPACK#	O	INPACK#	O
61	REG#	I	REG#	I	REG#	I
62	BVD2	O	SPKR#	O	DASP#	I/O
63	BVD1	O	STSCHG#	O	PDIAG#	I/O
64	D8	I/O	D8	I/O	D8	I/O
65	D9	I/O	D9	I/O	D9	I/O
66	D10	I/O	D10	I/O	D10	I/O
67	CD2#	O	CD2#	O	CD2#	O
68	GND	-	GND	-	GND	-

N.C = Not connected internally. N.U = Not used.

Signal Description

Signal Name	I/O	Pin No.	Description
Address bus[A10-A0]	I	8, 11, 12, 22, 23, 24, 25, 26, 27, 28, 29	Signals A10-A0 are address bus. A0 is invalid in word mode. A10 is the MSB and A0 is the LSB.
Data bus[D15-D0]	I/O	41, 40, 39, 38, 37, 66, 65, 64, 6, 5, 4, 3, 2, 32, 31, 30	Signals D15-D0 are data bus. D0 is the LSB of the Even Byte of the Word. D8 is the LSB of the Odd Byte of the Word.
Card Enable[CE1#, CE2#] (PC Card Memory Mode)	I	7, 42	CE1# and CE2# are low active card select signals.
Card Enable[CE1#, CE2#] (PC Card I/O Mode)			
Chip Select[CS0#, CS1#] (IDE ATA Interface)			In IDE ATA Interface, CS0 is used to select the Command Block Registers. CS1 is used to select the Control Block Registers.
Output Enable[OE#] (PC Card Memory Mode)	I	9	OE# is used to gate Attribute and Common Memory Read data from the ATA Card.
Output Enable[OE#] (PC Card I/O Mode)			OE# is used to gate Attribute Memory Read data from the ATA Card.
ATA SEL# (IDE ATA Interface)			To enable IDE ATA Interface, this input should be grounded by the host.
Write Enable[WE#] (PC Card Memory Mode)	I	15	WE# is used for strobing Attribute and Common Memory Write data into the ATA Card.
Write Enable[WE#] (PC Card I/O Mode)			WE# is used for strobing Attribute Memory Write data into the ATA Card.
Write Enable[WE#] (IDE ATA Interface)			This input should be connected Vcc by the host.
I/O Read[IORD#] (PC Card I/O Mode)	I	44	IORD# is used to read data from the Card's I/O space.
I/O Read[IORD#] (IDE ATA Interface)			
I/O Write[IOWR#] (PC Card I/O Mode)	I	45	IOWR# is used to write data to the Card's I/O space.
I/O Write[IOWR#] (IDE ATA Interface)			
Ready[READY] (PC Card Memory Mode)	O	16	READY signal is set high when the ATA Card is ready to accept a new data transfer operation.
IREQ# (PC Card I/O Mode)			This signal of low level is indicates that the card is requesting software service to host, and high level indicates that the card is not requesting.
INTRQ (IDE ATA Interface)			This signal is active high interrupt request to the host.
Card Detection[CD1#, CD2#]	O	36, 67	CD1# and CD2# provided for proper detection of PC Card insertion.
Write Protect[WP] (PC Card Memory Mode)	O	33	This signal is held low because this card does not have a write protect switch.
IOIS16# (PC Card I/O Mode)			This output signal is asserted when the I/O port address is capable of 16-bit access.
IOCS16# (IDE ATA Interface)			

Attribute Memory Select[REG#] (PC Card Memory Mode)	I	61	When this signal is asserted, access is limited to Attribute Memory with OE#/WE# and I/O Space with IORD#/IOWR#.
Attribute Memory Select[REG#] (PC Card I/O Mode)			This input signal is not used for this mode and should be connected to Vcc by the host.
Attribute Memory Select[REG#] (IDE ATA Interface)			
Battery Voltage Detect[BVD2] (PC Card Memory Mode)	O	62	This output is driven to a high-level.
Audio Digital Waveform[SPKR#] (PC Card I/O Mode)			SPKR# is kept negated because this Card does not have digital audio output.
DASP# (IDE ATA Interface)			I/O
Card Reset[RESET] (PC Card Memory Mode)	I	58	By assertion of this signal, all registers of this Card are cleared. This signal should be kept to High-Z by the host for at least 1ms after Vcc applied.
Card Reset[RESET] (PC Card I/O Mode)			
Card Reset[RESET#] (IDE ATA Interface)			This input pin is the active low hardware reset from the host.
Wait[WAIT#] (PC card Memory Mode)	O	59	This signal is asserted to delay completion of the memory or I/O access cycle.
Wait[WAIT#] (PC card I/O Mode)			
IORDY (IDE ATA Interface)			
Input Port Acknowledge[INPACK#] (PC Card I/O Mode)	O	60	This signal is asserted when the Card is selected and can respond to an I/O Read cycle at the address on the address bus.
Input Port Acknowledge[INPACK#] (IDE ATA Interface)			
Battery Voltage Detect[BVD1] (PC Card Memory Mode)	O	63	This output is driven to a high-level.
STSCHG# (PC Card I/O Mode)			This signal is asserted low to alert the host to changes in the status of Configuration Status Register in the Attribute Memory Space.
PDIAG# (IDE ATA Interface)			I/O
Voltage Sense[VS1, VS2]	O	43, 57	VS1 is grounded so that the Card CIS can be read at 3.3V and VS2 is N.C.
Cable Select[CSEL] (PC card Memory Mode)	-	56	This signal is not used for this mode.
Cable Select[CSEL] (PC card I/O Mode)			
Cable Select[CSEL] (IDE ATA Interface)			I
Vcc	-	17, 51	5V or 3.3V power.
GND	-	1, 34, 35, 68	Ground.

BLOCK DIAGRAM

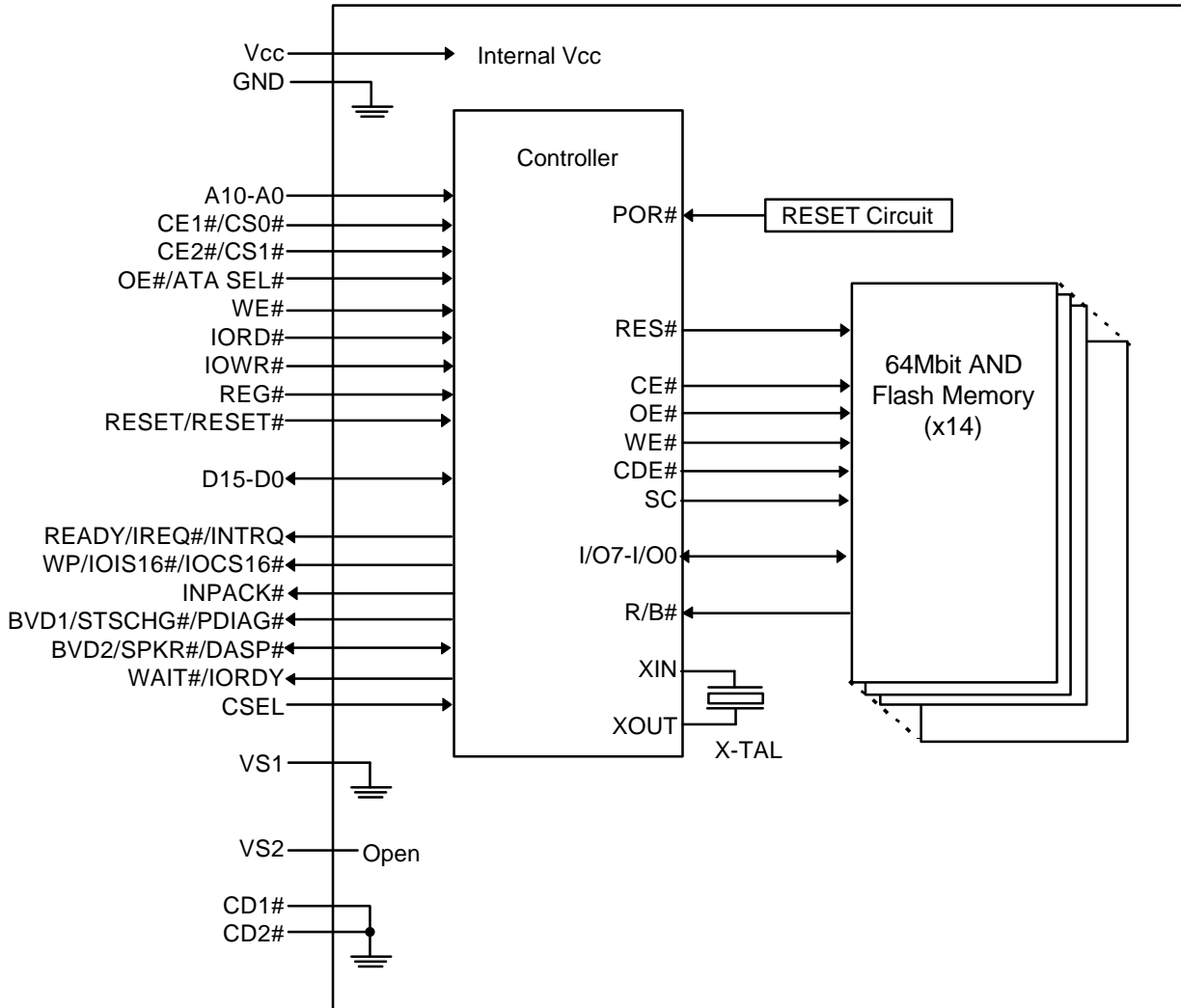

FUNCTION TABLE

Function	REG#	CE2#	CE1#	A0	OE#	WE#	IOR#	IOWR#	D15-D8	D7-D0
Attribute Memory Read Function										
Standby	X	H	H	X	X	X	X	X	High-Z	High-Z
Byte Access	L	H	L	L	L	H	H	H	High-Z	Even Byte
	L	H	L	H	L	H	H	H	High-Z	Invalid
Word Access	L	L	L	X	L	H	H	H	Invalid	Even Byte
Odd Byte	L	L	H	X	L	H	H	H	Invalid	High-Z
Attribute Memory Write Function										
Standby	X	H	H	X	X	X	X	X	don't care	don't care
Byte Access	L	H	L	L	H	L	H	H	don't care	Even Byte
	L	H	L	H	H	L	H	H	don't care	don't care
Word Access	L	L	L	X	H	L	H	H	don't care	Even Byte
Odd Byte	L	L	H	X	H	L	H	H	don't care	don't care
Common Memory Read Function										
Standby	X	H	H	X	X	X	X	X	High-Z	High-Z
Byte Access	H	H	L	L	L	H	H	H	High-Z	Even Byte
	H	H	L	H	L	H	H	H	High-Z	Odd Byte
Word Access	H	L	L	X	L	H	H	H	Odd Byte	Even Byte
Odd Byte	H	L	H	X	L	H	H	H	Odd Byte	High-Z
Common Memory Write Function										
Standby	X	H	H	X	X	X	X	X	don't care	don't care
Byte Access	H	H	L	L	H	L	H	H	don't care	Even Byte
	H	H	L	H	H	L	H	H	don't care	Odd Byte
Word Access	H	L	L	X	H	L	H	H	Odd Byte	Even Byte
Odd Byte	H	L	H	X	H	L	H	H	Odd Byte	don't care
I/O Read Function										
Standby	X	H	H	X	X	X	X	X	High-Z	High-Z
Byte Access	L	H	L	L	H	H	L	H	High-Z	Even Byte
	L	H	L	H	H	H	L	H	High-Z	Odd Byte
Word Access	L	L	L	X	H	H	L	H	Odd Byte	Even Byte
Odd Byte	L	L	H	X	H	H	L	H	Odd Byte	High-Z
I/O Write Function										
Standby	X	H	H	X	X	X	X	X	don't care	don't care
Byte Access	L	H	L	L	H	H	H	L	don't care	Even Byte
	L	H	L	H	H	H	H	L	don't care	Odd Byte
Word Access	L	L	L	X	H	H	H	L	Odd Byte	Even Byte
Odd Byte	L	L	H	X	H	H	H	L	Odd Byte	don't care

Memory mapped mode(Index=0)

REG#	CE2#	CE1#	A10	A9-A4	A3	A2	A1	A0	Register	
									OE#="L"	WE#="L"
1	0	0	0	x	0	0	0	x	Data Register(D15-D0)	Data Register(D15-D0)
1	1	0	0	x	0	0	0	0	Data Register[Even, Odd](D7-D0)	Data Register[Even, Odd](D7-D0)
1	1	0	0	x	0	0	0	1	Error Register(D7-D0)	Feature Register(D7-D0)
1	0	1	0	x	0	0	0	x	Error Register(D15-D8)	Feature Register(D15-D8)
1	0	0	0	x	0	0	1	x	Sector Count Register(D7-D0)	Sector Count Register(D7-D0)
									Sector Number Register(D15-D8)	Sector Number Register(D15-D8)
1	1	0	0	x	0	0	1	0	Sector Count Register(D7-D0)	Sector Count Register(D7-D0)
1	1	0	0	x	0	0	1	1	Sector Number Register(D7-D0)	Sector Number Register(D7-D0)
1	0	1	0	x	0	0	1	x	Sector Number Register(D15-D8)	Sector Number Register(D15-D8)
1	0	0	0	x	0	1	0	x	Cylinder Low Register(D7-D0)	Cylinder Low Register(D7-D0)
									Cylinder High Register(D15-D8)	Cylinder High Register(D15-D8)
1	1	0	0	x	0	1	0	0	Cylinder Low Register(D7-D0)	Cylinder Low Register(D7-D0)
1	1	0	0	x	0	1	0	1	Cylinder High Register(D7-D0)	Cylinder High Register(D7-D0)
1	0	1	0	x	0	1	0	x	Cylinder High Register(D15-D8)	Cylinder High Register(D15-D8)
1	0	0	0	x	0	1	1	x	Drive Head Register(D7-D0)	Drive Head Register(D7-D0)
									Status Register(D15-D8)	Command Register(D15-D8)
1	1	0	0	x	0	1	1	0	Drive Head Register(D7-D0)	Drive Head Register(D7-D0)
1	1	0	0	x	0	1	1	1	Status Register(D7-D0)	Command Register(D7-D0)
1	0	1	0	x	0	1	1	x	Status Register(D15-D8)	Command Register(D15-D8)
1	0	0	0	x	1	0	0	x	Data Register(D15-D0)	Data Register(D15-D0)
1	1	0	0	x	1	0	0	0	Data Register[Even, Odd](D7-D0)	Data Register[Even, Odd](D7-D0)
1	1	0	0	x	1	0	0	1	Data Register[Odd](D7-D0)	Data Register[Odd](D7-D0)
1	0	1	0	x	1	0	0	x	Data Register[Odd](D15-D8)	Data Register[Odd](D15-D8)
1	0	0	0	x	1	1	0	x	invalid(D7-D0)	invalid(D7-D0)
									Error Register(D15-D8)	Feature Register(D15-D8)
1	1	0	0	x	1	1	0	0	invalid	invalid
1	1	0	0	x	1	1	0	1	Error Register(D7-D0)	Feature Register(D7-D0)
1	0	1	0	x	1	1	0	x	Error Register(D15-D8)	Feature Register(D15-D8)
1	0	0	0	x	1	1	1	x	Alt. Status Register(D7-D0)	Device Control Register(D7-D0)
									Drive Address Register(D15-D8)	invalid
1	1	0	0	x	1	1	1	0	Alt. Status Register(D7-D0)	Device Control Register(D7-D0)
1	1	0	0	x	1	1	1	1	Drive Address Register(D7-D0)	invalid
1	0	1	0	x	1	1	1	x	Drive Address Register(D15-D8)	invalid
1	0	0	1	x	x	x	x	x	Data Register(D15-D0)	Data Register(D15-D0)
1	1	0	1	x	x	x	x	0	Data Register[Even, Odd](D7-D0)	Data Register[Even, Odd](D7-D0)
1	1	0	1	x	x	x	x	1	Data Register[Odd](D7-D0)	Data Register[Odd](D7-D0)
1	0	1	1	x	x	x	x	x	Data Register[Odd](D15-D8)	Data Register[Odd](D15-D8)

Contiguous I/O Map(Index=1)

REG#	CE2#	CE1#	A9-A4	A3	A2	A1	A0	Register	
								IORD#="L"	IOWR#="L"
0	0	0	x	0	0	0	x	Data Register(D15-D0)	Data Register(D15-D0)
0	1	0	x	0	0	0	0	Data Register[Even, Odd](D7-D0)	Data Register[Even, Odd](D7-D0)
0	1	0	x	0	0	0	1	Error Register(D7-D0)	Feature Register(D7-D0)
0	0	1	x	0	0	0	x	Error Register(D15-D8)	Feature Register(D15-D8)
0	0	0	x	0	0	1	0	Sector Count Register(D7-D0) Sector Number Register(D15-D8)	Sector Count Register(D7-D0) Sector Number Register(D15-D8)
0	1	0	x	0	0	1	0	Sector Count Register(D7-D0)	Sector Count Register(D7-D0)
0	1	0	x	0	0	1	1	Sector Number Register(D7-D0)	Sector Number Register(D7-D0)
0	0	1	x	0	0	1	x	Sector Number Register(D15-D8)	Sector Number Register(D15-D8)
0	0	0	x	0	1	0	0	Cylinder Low Register(D7-D0) Cylinder High Register(D15-D8)	Cylinder Low Register(D7-D0) Cylinder High Register(D15-D8)
0	1	0	x	0	1	0	0	Cylinder Low Register(D7-D0)	Cylinder Low Register(D7-D0)
0	1	0	x	0	1	0	1	Cylinder High Register(D7-D0)	Cylinder High Register(D7-D0)
0	0	1	x	0	1	0	x	Cylinder High Register(D15-D8)	Cylinder High Register(D15-D8)
0	0	0	x	0	1	1	0	Drive Head Register(D7-D0) Status Register(D15-D8)	Drive Head Register(D7-D0) Command Register(D15-D8)
0	1	0	x	0	1	1	0	Drive Head Register(D7-D0)	Drive Head Register(D7-D0)
0	1	0	x	0	1	1	1	Status Register(D7-D0)	Command Register(D7-D0)
0	0	1	x	0	1	1	x	Status Register(D15-D8)	Command Register(D15-D8)
0	0	0	x	1	0	0	x	Data Register(D15-D0)	Data Register(D15-D0)
0	1	0	x	1	0	0	0	Data Register[Even, Odd](D7-D0)	Data Register[Even, Odd](D7-D0)
0	1	0	x	1	0	0	1	Data Register[Odd](D7-D0)	Data Register[Odd](D7-D0)
0	0	1	x	1	0	0	x	Data Register[Odd](D15-D8)	Data Register[Odd](D15-D8)
0	0	0	x	1	1	0	0	invalid(D7-D0) Error Register(D15-D8)	invalid(D7-D0) Feature Register(D15-D8)
0	1	0	x	1	1	0	0	invalid	invalid
0	1	0	x	1	1	0	1	Error Register(D7-D0)	Feature Register(D7-D0)
0	0	1	x	1	1	0	x	Error Register(D15-D8)	Feature Register(D15-D8)
0	0	0	x	1	1	1	0	Alt. Status Register(D7-D0) Drive Address Register(D15-D8)	Device Control Register(D7-D0) invalid
0	1	0	x	1	1	1	0	Alt. Status Register(D7-D0)	Device Control Register(D7-D0)
0	1	0	x	1	1	1	1	Drive Address Register(D7-D0)	invalid
0	0	1	x	1	1	1	x	Drive Address Register(D15-D8)	invalid

Primary(Secondary) I/O(Index=2, 3)

REG#	CE2#	CE1#	A9-A4	A3	A2	A1	A0	Register	
								IORD#="L"	IOWR#="L"
0	0	0	1Fh(17h)	0	0	0	x	Data Register(D15-D0)	Data Register(D15-D0)
0	1	0	1Fh(17h)	0	0	0	0	Data Register[Even, Odd](D7-D0)	Data Register[Even, Odd](D7-D0)
0	1	0	1Fh(17h)	0	0	0	1	Error Register(D7-D0)	Feature Register(D7-D0)
0	0	1	1Fh(17h)	0	0	0	x	Error Register(D15-D8)	Feature Register(D15-D8)
0	0	0	1Fh(17h)	0	0	1	0	Sector Count Register(D7-D0)	Sector Count Register(D7-D0)
								Sector Number Register(D15-D8)	Sector Number Register(D15-D8)
0	1	0	1Fh(17h)	0	0	1	0	Sector Count Register(D7-D0)	Sector Count Register(D7-D0)
0	1	0	1Fh(17h)	0	0	1	1	Sector Number Register(D7-D0)	Sector Number Register(D7-D0)
0	0	1	1Fh(17h)	0	0	1	x	Sector Number Register(D15-D8)	Sector Number Register(D15-D8)
0	0	0	1Fh(17h)	0	1	0	0	Cylinder Low Register(D7-D0)	Cylinder Low Register(D7-D0)
								Cylinder High Register(D15-D8)	Cylinder High Register(D15-D8)
0	1	0	1Fh(17h)	0	1	0	0	Cylinder Low Register(D7-D0)	Cylinder Low Register(D7-D0)
0	1	0	1Fh(17h)	0	1	0	1	Cylinder High Register(D7-D0)	Cylinder High Register(D7-D0)
0	0	1	1Fh(17h)	0	1	0	x	Cylinder High Register(D15-D8)	Cylinder High Register(D15-D8)
0	0	0	1Fh(17h)	0	1	1	0	Drive Head Register(D7-D0)	Drive Head Register(D7-D0)
								Status Register(D15-D8)	Command Register(D15-D8)
0	1	0	1Fh(17h)	0	1	1	0	Drive Head Register(D7-D0)	Drive Head Register(D7-D0)
0	1	0	1Fh(17h)	0	1	1	1	Status Register(D7-D0)	Command Register(D7-D0)
0	0	1	1Fh(17h)	0	1	1	x	Status Register(D15-D8)	Command Register(D15-D8)
0	0	0	3Fh(37h)	1	1	1	0	Alt. Status Register(D7-D0)	Device Control Register(D7-D0)
								Drive Address Register(D15-D8)	invalid
0	1	0	3Fh(37h)	1	1	1	0	Alt. Status Register(D7-D0)	Device Control Register(D7-D0)
0	1	0	3Fh(37h)	1	1	1	1	Drive Address Register(D7-D0)	invalid
0	0	1	3Fh(37h)	1	1	1	x	Drive Address Register(D15-D8)	invalid

IDE ATA Interface

CS1#	CS0#	A2-A0	Register	
			IORD#="L"	IOWR#="L"
1	0	0h	Data Register(D15-D0)	Data Register(D15-D0)
1	0	1h	Error Register(D7-D0)	Feature Register(D7-D0)
1	0	2h	Sector Count Register(D7-D0)	Sector Count Register(D7-D0)
1	0	3h	Sector Number Register(D7-D0)	Sector Number Register(D7-D0)
1	0	4h	Cylinder Low Register(D7-D0)	Cylinder Low Register(D7-D0)
1	0	5h	Cylinder High Register(D7-D0)	Cylinder High Register(D7-D0)
1	0	6h	Drive Head Register(D7-D0)	Drive Head Register(D7-D0)
1	0	7h	Status Register(D7-D0)	Command Register(D7-D0)
0	1	6h	Alt. Status Register(D7-D0)	Device Control Register(D7-D0)
0	1	7h	Drive Address Register(D7-D0)	invalid

Configuration Register Specifications

Configuration Option Register

This register is used for the configuration of the card configuration status and for the issuing soft reset to the card.

D7	D6	D5	D4	D3	D2	D1	D0
SRESET	LeviREQ	Index					

Name	R/W	Description
SRESET	R/W	Setting this bit to "1", places the card in the reset state. When the host returns this bit to "0", the function shall enter the same unconfigured, reset state as the card does following a power-up and hardware reset.
LeviREQ	R/W	If this bit is set to "0", card generates pulse mode interrupt. If this bit is set to "1", card generates level mode interrupts.
Index	R/W	This bits is used for select operation mode of the card as follows. When Power on, Card Hard Reset and Soft reset, this data is "000000" for the purpose of Memory card interface recognition. Index: 0 -> Memory mapped 1 -> Contiguous I/O mapped 2 -> Primary I/O mapped 3 -> Secondary I/O mapped

Configuration and Status Register

This register is used for observing the card state.

D7	D6	D5	D4	D3	D2	D1	D0
Changed	SigChg	lois8	0	0	PwrDwn	Intr	0

Name	R/W	Description
Changed	R/O	This bit indicates that CREADY bit on the Pin Replacement register is set to "1". When Changed bit is set to "1", STSCHG# pin is held "L" if the SigChg bit is "1" and the card is configured for the I/O interface.
SigChg	R/W	This bit is set or reset by the host for enabling and disabling the status change signal(STSCHG# pin). When the card is configured I/O card interface and this bit is set to "1", STSCHG# pin is controlled by Changed bit. If this bit is set to "0", STSCHG# pin is kept "H".
lois8	R/W	This card is always configured for both 8-bit and 16-bit I/O, so this bit is ignored.
PwrDwn	R/W	When this bit is set to "1", the card enters Power Down mode. When this bit is reset to "0", the host is requesting the card to enter the active mode. RREADY bit on Pin Replacement Register becomes BUSY when this bit is changed. RREADY will not become Ready until the power state requested has been entered. This card automatically powers down when it is idle, and powers back up when it receives a command.
Intr	R/W	This bit represents the internal state of the interrupt request. This bit state is available whether I/O card interface has been configured or not. This signal remains true until the condition which caused the interrupt request has been serviced. If interrupts are disabled by the nIEN bit in the Device Control Register, this bit is a zero.

Pin Replacement Register

This register is used for providing the signal state of READY signal when the card configured I/O card interface.

D7	D6	D5	D4	D3	D2	D1	D0
0	0	CREADY	0	1	1	RREADY	0

Name	R/W	Description
CREADY	R/W	This bit is set to "1" when the RREADY bit changes state. This bit may also be written by the host.
RREADY	R/W	When read, this bit indicates READY pin states. When written, this bit acts as a mask for writing the CREADY bit.

Socket and Copy Register

This register is used for identification of the card from the other cards. Host can read and write this register. This register should be set by host before this card's Configuration Option register set.

D7	D6	D5	D4	D3	D2	D1	D0
0	Copy Number				Socket Number		

Name	R/W	Description
Copy Number	R/W	This bit indicates the drive number of the card for twin card configuration. And the host can select and drive one card by comparing the number in this field with the drive number of Drive Head Register. In the way, the host can perform the card's master/slave organization.
Socket Number	R/W	This field indicates to the card that it is located in the n'th socket.

CIS Information

CIS informatoins are defined as follows.

Offset	Data	7	6	5	4	3	2	1	0	Description
0000h	01h	CISTPL_DEVICE								Common Memory device information
0002h	03h	TPL_LINK								Link to next tuple
0004h	D9h	Device Type				WPS		Device Speed		Device Type=Dh : Function specific WPS=1 : No WPS Device Speed=1 : 250ns
0006h	01h	1x				2K				2kBytes of address space
0008h	FFh	Marks end of Device Info fields								
000Ah	1Ch	CISTPL_DEVICE_OC								Other Conditions Device information
000Ch	05h	TPL_LINK								Link to next tuple
000Eh	02h	EXT	Reserved				Vcc	MWAIT		EXT=0, Vcc=5.0V, Wait is not used.
0010h	DFh	Device Type				WPS		Device Speed		Device Type=Dh : Function specific WPS=1 : No WPS Device Speed=250ns
0012h	01h	1x				2K				2kbytes of address space
0014h	FFh	Marks end of Other Conditions Device Info								
0016h	1Ch	CISTPL_DEVICE_OC								Other Conditions Device information
0018h	04h	TPL_LINK								Link to next tuple
001Ah	02h	EXT	Reserved				Vcc	MWAIT		EXT=0, Vcc=3.3V, Wait is not used.
001Ch	D9h	Device Type				WPS		Device Speed		Device Type=Dh : Function specific WPS=1 : No WPS Device Speed=250ns
001Eh	01h	1x				2K				2kbytes of address space
0020h	FFh	Marks end of Other Conditions Device Info								
0022h	18h	CISTPL_JEDEC_C								JEDEC Identifier Tuples
0024h	02h	TPL_LINK								Link to next tuple
0026h	DFh	JEDEC identifier for first device info entry.								PC Card ATA
0028h	01h	JEDEC identifiers for remaining device info entries.								with no Vpp require for any operation
002Ah	20h	CISTPL_MANFID								Manufacturer Identification Tuple
002Ch	04h	TPL_LINK								Link to next tuple
002Eh	1Ch	PC Card manufacturer code								001Ch
0030h	00h									
0032h	01h	manufacturer information								0001h
0034h	00h									
0036h	15h	CISTPL_VERS_1								Level 1 Version / Product Information
0038h	26h	TPL_LINK								Link to next tuple
003Ah	04h	TPLL1_MAJOR								PCMCIA2.0 / JEIDA4.1
003Ch	01h	TPLL1_MINOR								PCMCIA2.0 / JEIDA4.1
003Eh	4Dh	TPLL1_INFO								M
0040h	49h									I
0042h	54h									T
0044h	53h									S
0046h	55h									U
0048h	42h									B
004Ah	49h									I
004Ch	53h									S
004Eh	48h									H
0050h	49h									I
0052h	20h									
0054h	41h									A
0056h	54h									T
0058h	41h									A
005Ah	20h									
005Ch	43h									C
005Eh	41h									A
0060h	52h									R
0062h	44h									D
0064h	00h									
0066h	4Dh									M
0068h	46h									F

ATA PC CARDS

006Ah	30h										0	
006Ch	78h										x	
006Eh	78h										x	
0070h	78h										x	
0072h	78h										x	
0074h	2Dh										-	
0076h	30h										0	
0078h	33h										3	
007Ah	41h										A	
007Ch	54h										T	
007Eh	58h										x	
0080h	78h										x	
0082h	00											
0084h	FFh										Marks end of chain.	
0086h	21h	CISTPL_FUNCID									Function Identification Tuple	
0088h	02h	TPL_LINK									Link to next tuple	
008Ah	04h	Card Function Code									PC Card ATA(Fixed Disk)	
008Ch	01h	Reserved			ROM	POST						ROM=0 : No BIOS ROM POST=1: Configure card at power on
008Eh	22h	CISTPL_FUNC									Function Extension Tuple	
0090h	02h	TPL_LINK									Link to next tuple	
0092h	01h	Disk Function Extension Tuple Type									Disk Interface Type	
0094h	01h	Disk Interface Type									PC Card ATA Interface	
0096h	22h	CISTPL_FUNC									Function Extension Tuple	
0098h	03h	TPL_LINK									Link to next tuple	
009Ah	02h	Disk Function Extension Tuple Type									Basic PC Card ATA Interface tuple	
009Ch	04h	RFU		D	U	S	V				V=0 : No Vpp Required S=1 : Silicon U=0 : ID Drive Mfg/SN not Unique D=0 : Single Drive on Card	
009Eh	0Fh	RFU	I	E	N	P3	P2	P1	P0		P0=1 : Sleep Mode Supported P1=1 : Standby Mode Supported P2=1 : Idle Mode Supported P3=1 : Drive Auto Power Control N=0 : No Configs exclude I/O port 3F7H/377H E=0 : Index bit is not emulated I=0 : IOIS16# use is Unspecified on Twin Card Configurations	
00A0h	1Ah	CISTPL_CONF									Configuration Tuple	
00A2h	05h	TPL_LINK									Link to next tuple	
00A4h	01h	RFS			RMS			RAS			RFS=0 : No Reserved Field RMS=0 : 1 Byte Register Mask RAS=1 : 2 Byte Config Base Address	
00A6h	03h	TPCC_LAST									Last Index = 3	
00A8h	00h	TPCC_RADR (lsb)									Configuration Registers are located	
00AAh	02h	TPCC_RADR (msb)									at 200H in Reg Space	
00ACh	0Fh	RFU	RFU	RFU	E	S	P	C	I		First 4 Configuration Registers present	
00AEh	1Bh	CISTPL_CFTABLE_ENTRY									Configuration Table Entry Tuple	
00B0h	08h	TPL_LINK									Link to next tuple	
00B2h	C0h	I	D		Configuration Index						Interface Byte Follows, Default Entry, Configuration Index = 0	
00B4h	40h	W	R	P	B	Interface Type					Mem Interface; Bvd's and wProt not used; Ready active and Wait not used for memory cycles.	
00B6h	A1h	M	MS		IR	IO	T	P			Has Vcc, Mem Space and Misc Info	
00B8h	01h	R	DI	PI	AI	SI	HV	LV	NV		Nominal Voltage Only Follows	
00BAh	55h	X	Mantissa				Exponent				Vcc Nominal is 5 Volts	
00BCh	08h	Length in 256 bytes pages (lsb)									Length of Mem Space is 2 KB	
00BEh	00h	Length in 256 bytes pages (msb)									Starts at 0 on card	
00C0h	21h	X	RFU	P	RO	A	T				Power Down, Twin Card supported.	
00C2h	1Bh	CISTPL_CFTABLE_ENTRY									Configuration Table Entry Tuple	
00C4h	05h	TPL_LINK									Link to next tuple	
00C6h	00h	I	D		Configuration Index						No Interface Byte, Non Default Entry,	



ATA PC CARDS

00C8h	01h	M	MS		IR	IO	T	P		Configuration Index = 0
00CAh	01h	R	DI	PI	AI	SI	HV	LV	NV	Has Vcc Info
00CCh	B5h	X	Mantissa				Exponent			Nominal Voltage Only Follows
00CEh	1Eh	Extension								Vcc Nominal is 3.3 Volts
00D0h	1Bh	CISTPL_CFTABLE_ENTRY								Configuration Table Entry Tuple
00D2h	0Ah	TPL_LINK								Link to next tuple
00D4h	C1h	I	D	Configuration Index						Interface Byte Follows, Default Entry, Configuration Index = 1
00D6h	41h	W	R	P	B	Interface Type				I/O Interface; Bvd's and wProt not used; Ready active and Wait not used for memory cycles.
00D8h	99h	M	MS		IR	IO	T	P		Has Vcc, I/O, IRQ and Misc Info
00DAh	01h	R	DI	PI	AI	SI	HV	LV	NV	Nominal Voltage Only Follows
00DCh	55h	X	Mantissa				Exponent			Vcc Nominal is 5 Volts
00DEh	64h	R	S	E	IO AddrLines					I/O : Range=0, Bus16=1, Bus8=1, IO AddrLines=4
00E0h	F0h	S	P	L	M	Level or Mask				Share=1, Pulse=1, Level=1, Mask=1
00E2h	FFh	IRQ7	IRQ6	IRQ5	IRQ4	IRQ3	IRQ2	IRQ1	IRQ0	IRQ Level to be routed 0 - 15 recommended.
00E4h	FFh	IRQ15	IRQ14	IRQ13	IRQ12	IRQ11	IRQ10	IRQ9	IRQ8	
00E6h	21h	X	RFU	P	RO	A	T			Power Down, Twin Card supported.
00E8h	1Bh	CISTPL_CFTABLE_ENTRY								Configuration Table Entry Tuple
00EAh	05h	TPL_LINK								Link to next tuple
00ECh	01h	I	D	Configuration Index						No Interface Byte, Non Default Entry, Configuration Index = 1
00EEh	01h	M	MS		IR	IO	T	P		Has Vcc Info
00F0h	01h	R	DI	PI	AI	SI	HV	LV	NV	Nominal Voltage Only Follows
00F2h	B5h	X	Mantissa				Exponent			Vcc Nominal is 3.3 Volts
00F4h	1Eh	Extension								
00F6h	1Bh	CISTPL_CFTABLE_ENTRY								Configuration Table Entry Tuple
00F8h	0Fh	TPL_LINK								Link to next tuple
00FAh	C2h	I	D	Configuration Index						Interface Byte Follows, Default Entry, Configuration Index = 2
00FCh	41h	W	R	P	B	Interface Type				I/O Interface; Bvd's and wProt not used; Ready active and Wait not used for memory cycles.
00FEh	99h	M	MS		IR	IO	T	P		Has Vcc, I/O, IRQ and Misc Info
0100h	01h	R	DI	PI	AI	SI	HV	LV	NV	Nominal Voltage Only Follows
0102h	55h	X	Mantissa				Exponent			Vcc Nominal is 5 Volts
0104h	EAh	R	S	E	IO AddrLines					I/O : Range=1, Bus16=1, Bus8=1, IO AddrLines=10
0106h	61h	LS		AS		N Ranges				Number of Address Ranges = 2 Address Size = 2 Length Size = 1
0108h	F0h	First I/O Base Address (LSB)								First I/O Base Address = 1F0h
010Ah	01h	First I/O Base Address (MSB)								
010Ch	07h	First I/O Length minus 1								First I/O Range is 8 Byte Length
010Eh	F6h	Second I/O Base Address (LSB)								Second I/O Base Address = 3F6h
0110h	03h	Second I/O Base Address (MSB)								
0112h	01h	Second I/O Length minus 1								Second I/O Range is 2 Byte Length
0114h	EEh	S	P	L	M	IRQ Level				Share=1, Pulse=1, Level=1, Mask=0, IRQ14 is recommended.
0116h	21h	X	RFU	P	RO	A	T			Power Down, Twin Card supported.
0118h	1Bh	CISTPL_CFTABLE_ENTRY								Configuration Table Entry Tuple
011Ah	05h	TPL_LINK								Link to next tuple
011Ch	02h	I	D	Configuration Index						No Interface Byte, Non Default Entry, Configuration Index = 2
011Eh	01h	M	MS		IR	IO	T	P		Has Vcc Info
0120h	01h	R	DI	PI	AI	SI	HV	LV	NV	Nominal Voltage Only Follows
0122h	B5h	X	Mantissa				Exponent			Vcc Nominal is 3.3 Volts
0124h	1Eh	Extension								
0126h	1Bh	CISTPL_CFTABLE_ENTRY								Configuration Table Entry Tuple
0128h	0Fh	TPL_LINK								Link to next tuple
012Ah	C3h	I	D	Configuration Index						Interface Byte Follows, Default Entry,

ATA PC CARDS

012Ch	41h	W	R	P	B	Interface Type				Configuration Index = 3 I/O Interface; Bvd's and wProt not used; Ready active and Wait not used for memory cycles.	
012Eh	99h	M	MS		IR	IO	T	P		Has Vcc, I/O, IRQ and Misc Info	
0130h	01h	R	DI	PI	AI	SI	HV	LV	NV	Nominal Voltage Only Follows	
0132h	55h	X	Mantissa				Exponent				Vcc Nominal is 5 Volts
0134h	EAh	R	S	E	IO AddrLines					I/O : Range=1, Bus16=1, Bus8=1, IO AddrLines=10	
0136h	61h	LS		AS		N Ranges				Number of Address Ranges = 2 Address Size = 2 Length Size = 1	
0138h	70h	First I/O Base Address (LSB)								First I/O Base Address = 170h	
013Ah	01h	First I/O Base Address (MSB)									
013Ch	07h	First I/O Length minus 1								First I/O Range is 8 Byte Length	
013Eh	76h	Second I/O Base Address (LSB)								Second I/O Base Address = 376h	
0140h	03h	Second I/O Base Address (MSB)									
0142h	01h	Second I/O Length minus 1								Second I/O Range is 2 Byte Length	
0144h	EEh	S	P	L	M	IRQ Level				Share=1, Pulse=1, Level=1, Mask=0, IRQ14 is recommended.	
0146h	21h	X	RFU	P	RO	A	T			Power Down, Twin Card supported.	
0148h	1Bh	CISTPL_CFTABLE_ENTRY								Configuration Table Entry Tuple	
014Ah	05h	TPL_LINK								Link to next tuple	
014Ch	03h	I	D	Configuration Index						No Interface Byte, Non Default Entry, Configuration Index = 3	
014Eh	01h	M	MS		IR	IO	T	P		Has Vcc Info	
0150h	01h	R	DI	PI	AI	SI	HV	LV	NV	Nominal Voltage Only Follows	
0152h	B5h	X	Mantissa				Exponent				Vcc Nominal is 3.3 Volts
0154h	1Eh	Extension									
0156h	FFh	CISTPL_END								End of List Tuple	

ATA Register Specifications

Data Register

This register is a 16 bit register which is used to transfer data blocks between the card data buffer and the host. Data may be transferred by either a series of word accesses to the Data register or a series of byte accesses to the Data register.

D15	D14	D13	D12	D11	D10	D9	D8
Data Word							
Odd Data Byte							

D7	D6	D5	D4	D3	D2	D1	D0
Data Word							
Data Byte							

Error Register

This register contains additional information about the source of an error which has occurred in processing of the preceding command. This register should be checked by the host when ERR bit in the Status register is set. The Error register is a read only register.

D7	D6	D5	D4	D3	D2	D1	D0
BBK	UNC	0	IDNF	0	ABRT	0	AMNF

Field	function
BBK	This bit is set when a Bad Block is detected in requested ID field. Host can not read/write on data area that is marked as a Bad Block.
UNC	This bit is set when Uncorrectable error is occurred at reading the card.
IDNF	The requested sector ID is in error or cannot be found.
ABRT	This bit is set if the command has been aborted because of the card status condition. (Not ready, Write fault, etc.) or when an invalid command has been issued.
AMNF	This bit is set in case of a general error.

Feature Register

This register is written by the host to provide command specific information to the drive regarding features of the drive which the host wish to utilize. The Feature register is a write only register.

D7	D6	D5	D4	D3	D2	D1	D0
Feature byte							

Sector Count Register

This register is written by the host with the number of sectors or blocks to be processed in the subsequent command. After the command is complete, the host may read this register to obtain the count of sectors left unprocessed by the command.

D7	D6	D5	D4	D3	D2	D1	D0
Sector Count							

Sector Number Register

This register is written by the host with the starting sector number to be used in the subsequent Cylinder-Head-Sector command. After the command is complete, the host may read the final sector number from this register. When logical block addressing is used, this register is written by the host with bit7 to 0 of the starting logical block number and contains bit7 to 0 of the final logical block number after the command is complete.

D7	D6	D5	D4	D3	D2	D1	D0
Sector Number							
Logical Block Number bits A07-A00(LBA Addressing)							

Cylinder Low Register

This register is written by the host with the low-order byte of the starting cylinder address to be used in the subsequent Cylinder-Head-Sector command. After the command is complete, the host may read the low-order byte of the final cylinder number from this register. When logical block addressing is used, this register is written by the host with bits15 to 8 of the starting logical block number and contains bits15 to 8 of the final logical block number after the command complete.

D7	D6	D5	D4	D3	D2	D1	D0
Cylinder Low Byte							
Logical Block Number bits A15-A08(LBA Addressing)							

Cylinder High Register

This register is written by the host with the high-order byte of the starting cylinder address to be used in the subsequent Cylinder-Head-Sector command. After the command is complete, the host may read the high-order byte of the final cylinder number from this register. When logical block addressing is used, this register is written by the host with bits 23 to 16 of the starting logical block number and contains bits23 to 16 of the final logical block number after the command is complete.

D7	D6	D5	D4	D3	D2	D1	D0
Cylinder High Byte							
Logical Block Number bits A23-A16(LBA Addressing)							

Drive/Head Register

The Drive/Head register is used to specify the selected drive of a pair of drives sharing a set of registers.

D7	D6	D5	D4	D3	D2	D1	D0
X	LBA	X	DRV	HS3 LBA27	HS2 LBA26	HS1 LBA25	HS0 LBA24

Field	function
X	Undefined . "0" or "1".
LBA	This bit is "0" for CHS addressing and "1" for Logical Block addressing.
DRV	This bit is number of the drive which the host has selected. When DRV is cleared, Drive0 is selected. When DRV is set, Drive1 is selected. The card is selected to be Drive0 or to be Drive1 using the "Copy" field of the PC Card Socket Copy Register.

HS3-0 LBA27-24	HS3-0 of the head number in CHS addressing or LBA27-24 of the Logical Block Number in LBA addressing.
-------------------	---

Status and Alternate Status Registers

The Status register and the Alternate Status register return the card status when read by the host. Reading the Status register clears a pending interrupt request while reading the Alternate Status register does not. The Status register and the Alternate Status register are read only registers.

D7	D6	D5	D4	D3	D2	D1	D0
BSY	DRDY	DWF	DSC	DRQ	CORR	IDX	ERR

Field	function
BSY	This bit is set when the card internal operation is executing. When this bit is set to "1", other bits in this register are invalid.
DRDY	DRDY indicates whether the card is capable of performing card operations.
DWF	This bit, if set, indicates a write fault has occurred.
DSC	This bit is set when the drive seek complete.
DRQ	This bit is set when the information can be transferred between the host and Data register.
CORR	This bit is set when a correctable data error has been occurred and the data has been corrected.
IDX	This bit is always set to "0".
ERR	This bit is set when the previous command has ended in some type of error. The error information is set in the other Status register bits or Error register. This bit is cleared by the next command.

Command Register

The Command register contains the command code being sent to the device. Command execution begins immediately after this register is written. The Command register is a write only register.

D7	D6	D5	D4	D3	D2	D1	D0
Command							

Device Control Register

This register is used to control the card interrupt request and to issue a soft reset to the card. The Device Control register is a write only register.

D7	D6	D5	D4	D3	D2	D1	D0
X	X	X	X	1	SRST	nIEN	0

Field	function
X	don't care.
1	This bit is set to "1".
SRST	This bit is set to "1" in order to force the card to perform a Command Block Reset operation. This does not change the Card Configuration registers as a Hardware Reset does. The card remains in Reset until this bit is reset to "0".
nIEN	This bit is used for enabling IREQ#. When this bit is set to "0", IREQ# is enabled. When this bit is set to "1", IREQ# is disabled.
0	This bit is set to "0".

Drive Address Register

This register is provided for compatibility with the AT disk drive interface.

D7	D6	D5	D4	D3	D2	D1	D0
X	nWTG	nHS3-0				nDS1	nDS0

Field	function
X	This bit is unknown.
nWTG	This bit is set to "0" when a Flash write operation is in progress, otherwise it is set to "1".
nHS3-0	These bits is the negative value of Head Select bits in Drive/Head register.
nDS1	This bit is set to "0" when Slave drive is active and selected.
nDS0	This bit is set to "0" when Master drive is active and selected.

ATA Command Specifications

This table summarizes the ATA command set with the paragraphs. Following shows the support commands and command codes which are written in command registers.

Command	Code	FR	SC	SN	CY	DR	HD
Check Power Mode	98h, E5h					y	
Execute Drive Diagnostic	90h					y	
Erase Sector(s)	C0h		y	y	y	y	y
Format Track	50h		y		y	y	y
Identify Drive	ECh					y	
Idle	97h, E3h		y			y	
Idle Immediate	95h, E1h					y	
Initialize Drive Parameters	91h		y			y	y
Read Buffer	E4h					y	
Read Long Sector	22h, 23h			y	y	y	y
Read Multiple	C4h		y	y	y	y	y
Read Sector(s)	20h, 21h		y	y	y	y	y
Read Verify Sector(s)	40h, 41h		y	y	y	y	y
Recalibrate	1xh					y	
Request Sense	03h					y	
Seek	7xh			y	y	y	y
Set Features	EFh	y	y			y	
Set Multiple mode	C6h		y			y	
Set Sleep Mode	99h, E6h					y	
Standby	96h, E2h					y	
Standby Immediate	94h, E0h					y	
Wear Level	F5h					y	
Write Buffer	E8h					y	
Write Long Sector	32h, 33h			y	y	y	y
Write Multiple	C5h		y	y	y	y	y
Write Multiple without Erase	CDh		y	y	y	y	y
Write Sector(s)	30h, 31h		y	y	y	y	y
Write Sector without Erase	38h		y	y	y	y	y
Write Verify	3Ch		y	y	y	y	y
FR : Feature Register,		SC : Sector Count Register,					
SN : Sector Number Register,		CY : Cylinder Low/High Register,					
DR Drive bit of Drive/Head Register,		HD : Head No. of Drive/Head Register,					

Check Power Mode(98h, E5h)

This command checks the power mode.

Execute Drive Diagnostic(90h)

This command performs the internal diagnostic tests implemented by the card.

Erase Sector(s)(C0h)

This command is used to pre-erase and condition data sectors in advance of a Write without Erase or Write Multiple without Erase command.

Format Track(50h)

This command writes the desired head and cylinder of the selected drive with a FFh pattern.

Identify Drive(ECh)

This command enables the host to receive parameter information from the card. (Refer to the Identify Drive Information table.)

Idle(97h, E3h)

This command causes the card to set BSY, enter the Idle mode, clear BSY and generate an interrupt. If the sector count is non-zero, the automatic power down mode is enabled. If the sector count is zero, the automatic power down mode is disabled.

Idle Immediate(95h, E1h)

This command causes the card to set BSY, enter the idle mode, clear BSY and generate an interrupt.

Initialize Drive Parameters(91h)

This command allows the host to alter the number of sectors per track and the number of heads per cylinder.

Read Buffer(E4h)

This command enables the host to read the current contents of the card's sector buffer.

Read Long Sector(22h, 23h)

This command is similar to the Read Sector(s) command except the contents of the Sector Count register are ignored and only one sector is read. The 512 data bytes and 4 ECC bytes are read into the buffer(with no ECC correction) and then transferred to the host.

Read Multiple(C4h)

This command performs similarly to the Read Sector(s) command. Interrupt are not generated on each sector, but on the transfer of a block which contains the number of sectors defined by a Set Multiple command.

Read Sector(s)(20h, 21h)

This command transfers data from the card to the host. Data transfer starts at the sector specified by the Cylinder, Head, and Sector Number registers, and proceeds for the number of sectors specified in the Sector Count register.

Read Verify Sector(s)(40h, 41h)

This command is identical to the Read Sector(s) command, except that DRQ is not asserted, and no data is transferred to the host.

Recalibrate(1xh)

Although this command is supported for backward compatibility, it has no actual function. The card will always return good status at the completion of this command.

Request Sense(03h)

This command requests extended error information for the previous command.

Seek(7xh)

This command is supported for backward compatibility. Although this command has no actual function, it does perform a range check of valid track, and posts an IDNF error if the Head or Cylinder specified are out of bounds.

Set Features(EFh)

This command is used by the host to establish or select certain features.

Set Multiple Mode(C6h)

This command enables the card to perform Read and Write Multiple operations and establishes the block count for these commands. This card supports 1 sector block size.

Set Sleep Mode(E6h, 99h)

This command causes the card to set BSY, enter the Sleep mode, clear BSY and generate an interrupt.

Standby(96h, E2h)

This command causes the card to set BSY, enter the Standby mode, clear BSY and generate an interrupt.

Standby Immediate(94h, E0h)

This command causes the card to set BSY, enter the Standby mode, clear BSY and generate an interrupt.

Wear Leveling(F5h)

Although this command is supported for backward compatibility, it has no actual function. The card will always return good status at the completion of this command.

Write Buffer(E8h)

This command enables the host to overwrite contents of the card's sector buffer with any data pattern desired. This command has the same protocol as the Write Sector(s) command and transfers 512 bytes.

Write Long Sector(32h, 33h)

This command is similar to the Write Sector(s) except the contents of the Sector Count register are ignored and only

one sector is written. The 512 data bytes and 4 ECC bytes are transferred from the host and then written from the buffer to the flash.

Write Multiple(C5h)

This command is similar to the Write Sector(s) command. Interrupts are not presented on each sector, but on the transfer of a block which contains the number of sectors defined by Set Multiple command.

Write Sector(s)(30h, 31h)

This command transfers data from the host to the card. Data transfer starts at the sector specified by the Cylinder, Head, and Sector Number registers, and proceeds for the number of sectors specified in the Sector Count register.

Write Verify(3Ch)

This command is similar to the Write Sector(s) command, except each sector is verified immediately after being written.

Identify Drive Information

Word Address	Data	Description
0	848Ah	General configuration bit-significant information
		15 1 Non-rotating disk drive
		14 0 Format speed tolerance gap not required
		13 0 Track offset option not available
		12 0 Data strobe offset option not available
		11 0 Rotational speed tolerance is < 0.5%
		10 1 Disk transfer rate > 10Mbps
		9 0 10Mbps <= Disk transfer rate > 5Mbps
		8 0 Disk transfer rate <= 5Mbps
		7 1 Removable cartridge drive
		6 0 Not a fixed drive
		5 0 Spindle motor control option not implemented
		4 0 Head switch time > 15us
		3 1 Not MFM encoded
		2 0 Not soft sectored
		1 1 Hard sectored
0 0 Reserved		
1	xxxxh	Number of Cylinders
2	0000h	Reserved
3	000xh	Number of Heads
4	4000h	Number of unformatted bytes per track
5	0200h	Number of unformatted bytes per sector
6	0020h	Number of sectors per track
7-8	xxxxh, xxxxh	Number of sectors per card (word 7 = MSW, word 8 = LSW)
9	0000h	Reserved
10-19	2020h	Reserved
20	0001h	Buffer type: Single ported, single-sector, w/read cache
21	0001h	Buffer size, in 512 byte increments
22	0004h	ECC length used on Read and Write Long command
23-26	xxxxh	Firmware revision, 8 ASCII chars
27-46	xxxxh	Model number, 40 ASCII chars.
47	0001h	Maximum Block Count=1 for Read/write Multiple commands
48	0000h	Cannot perform doubleword I/O
49	0200h	Capabilities: LBA supported, DMA not supported
50	0000h	Reserved
51	0100h	PIO timing cycle timing mode 1
52	0000h	DMA transfer not supported
53	0001h	Words 54-58 are valid
54	xxxxh	Number of Current Cylinders
55	xxxxh	Number of Current Heads
56	xxxxh	Number of Current Sectors per Track
57	xxxxh	LSW of the Current Capacity in Sectors
58	0000h	MSW of the Current Capacity in Sectors
59	010xh	Current Setting for Block Count for R/W Multiple commands
60	xxxxh	LSW of the total number of user addressable LBA mode
61	xxxxh	MSW of the total number of user addressable LBA mode
62-255	0000h	Reserved

ABSOLUTE MAXIMUM RATINGS

Symbol	Parameter	Conditions	Ratings	Unit
V _{CC}	Supply voltage	With respect to GND	-0.3~7.0	V
V _i	Input voltage		-0.3~V _{CC} +0.3	V
V _o	Output voltage		-0.3~V _{CC} +0.3	V
P _d	Power dissipation	T _a = 25 °C	1.2	W
T _{opr}	Operating temperature		0~60	°C
T _{stg}	Storage temperature		-10~80	°C

RECOMMENDED OPERATING CONDITIONS

Symbol	Parameter	Limits			Unit
		Min.	Typ.	Max.	
V _{CC} (5V)	V _{CC} Supply voltage	4.5	5.0	5.5	V
V _{CC} (3.3V)	V _{CC} Supply voltage	3.135	3.3	3.465	V
GND	System ground		0		V
V _{IH}	High input voltage	0.7V _{CC}		V _{CC}	V
V _{IL}	Low input voltage	0		0.8	V

DC ELECTRICAL CHARACTERISTICS (T_a=0~60°C, V_{CC}=5V±10% or V_{CC}=3.3V±5%, unless otherwise noted)

Symbol	Parameter	Test Condition	Limits				Unit	
			Min.		Typ.	Max.		
			3.135V	4.5V		3.465V		5.5V
V _{OH}	High output voltage	I _{OH} =2.0mA (3.135V) 4.0mA (4.5V)	0.8 V _{CC}			-	V	
		I _{OH} =3.5mA (3.135V) 7.0mA (4.5V)						
V _{OL}	Low output voltage	I _{OL} =-2.5mA (3.465V) -4.0mA (5.5V)				0.4	V	
		I _{OL} =-4.0mA (3.465V) -7.0mA (5.5V)						
I _{OZ}	Output current in off state	CE1# = CE2# = V _{IH} D15-D0				±5	µA	
I _{CCR}	Active supply current (Read)	Output open				70	mA	
I _{CCW}	Active supply current (Write)					100	mA	
I _{CCS}	Standby current (Auto power down)	CE1# = CE2# = V _{IH}				5	mA	

ATA PC CARDS

Symbol	Parameter	Test Condition	Limits					Unit	
			Min.		Typ.	Max.			
			3.135V	4.5V		3.465V	5.5V		
I _{IH}	High input current	V _{IN} =V _{CC}	CE1#,CE2#, OE#,WE#, IORD#,IOWR#, REG#, CSEL,RESET, D15-D0, A10-A0		-1		1		μA
			BVD1,BVD2		-5		5		
I _{IL}	Low input current	V _{IN} =GND PC card mode	CE1#,CE2#, OE#,WE#, REG#, IORD#,IOWR#		-14	-20	-90	-140	μA
			RESET		-7	-10	-45	-70	
			A10-A0, CSEL		-1		1		
			D15-D0		-5		5		
		V _{IN} =GND IDE mode	CE1#,CE2#, IORD#,IOWR#, A10-A0,RESET		-1		1		
			D15-D0		-5		5		
			OE#,WE#, REG#, BVD1,BVD2		-14	-20	-90	-140	
			CSEL		-7	-10	-45	-70	

CAPACITANCE

Symbol	Parameter	Test conditions	Limits			Unit
			Min.	Typ.	Max.	
C _I	Input capacitance	V _I =GND, V _i =25mVrms, f=1 MHz, T _a =25°C			45	pF
C _O	Output capacitance	V _O =GND, V _o =25mVrms, f=1 MHz, T _a =25°C			45	pF

Note : These parameters are not 100% tested.

AC ELECTRICAL CHARACTERISTICS

MEMORY TIMING

Read Cycle[Attribute] (Ta=0~60°C, VCC=5V±10% or VCC=3.3V±5% unless otherwise noted)

Symbol	Parameter	Limits			Unit
		Min.	Typ.	Max.	
tCR	Read cycle time	300			ns
ta(A)	Address access time			300	ns
ta(CE)	Card enable access time			300	ns
ta(OE)	Output enable access time			150	ns
tdis(CE)	Output disable time (from CE)			100	ns
tdis(OE)	Output disable time (from OE)			100	ns
ten(CE)	Output enable time (from CE)	5			ns
ten(OE)	Output enable time (from OE)	5			ns
tV(A)	Data valid time (after address change)	0			ns

Read Cycle[Common] (Ta=0~60°C, VCC=5V±10% or VCC=3.3V±5% unless otherwise noted)

Symbol	Parameter	Limits			Unit
		Min.	Typ.	Max.	
tCR	Read cycle time	250			ns
ta(A)	Address access time			250	ns
ta(CE)	Card enable access time			250	ns
ta(OE)	Output enable access time			125	ns
tdis(CE)	Output disable time (from CE)			100	ns
tdis(OE)	Output disable time (from OE)			100	ns
ten(CE)	Output enable time (from CE)	5			ns
ten(OE)	Output enable time (from OE)	5			ns
tV(A)	Data valid time after address change	0			ns

Write Cycle[Attribute and Common] (Ta=0~60°C, VCC=5V±10% or VCC=3.3V±5% unless otherwise noted)

Symbol	Parameter	Limits			Unit
		Min.	Typ.	Max.	
tCW	Write cycle time	250			ns
tw(WE)	Write pulse width	150			ns
tsu(A)	Address setup time	30			ns
tsu(A-WEH)	Address setup time with respect to WE high	180			ns
tsu(CE-WEH)	Card enable setup time with respect to WE high	180			ns
tsu(D-WEH)	Data setup time with respect to WE high	80			ns
th(D)	Data hold time	30			ns
trec(WE)	Write recovery time	30			ns
tdis(WE)	Output disable time (from WE)			100	ns
tdis(OE)	Output disable time (from OE)			100	ns
ten(WE)	Output enable time (from WE)	5			ns
ten(OE)	Output enable time (from OE)	5			ns
tsu(OE-WE)	OE set up time with respect to WE low	10			ns
th(OE-WE)	OE hold time with respect to WE high	10			ns

MEMORY TIMING DIAGRAM

Read Cycle

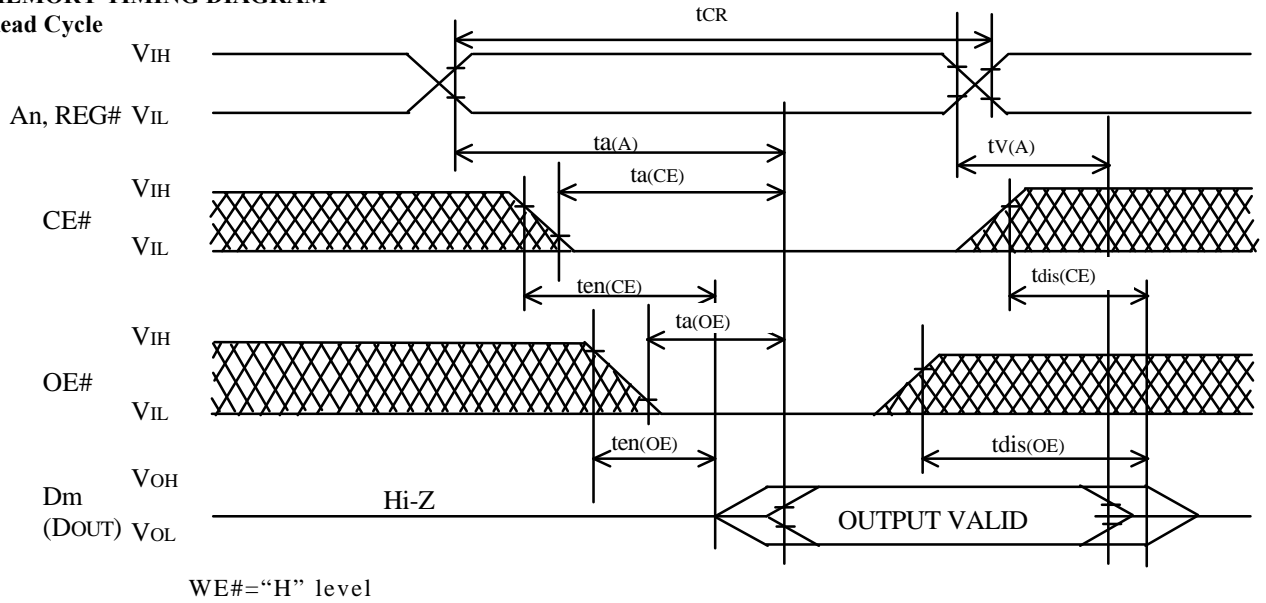

Note 5 :  Indicates the don't care input

Write Cycle

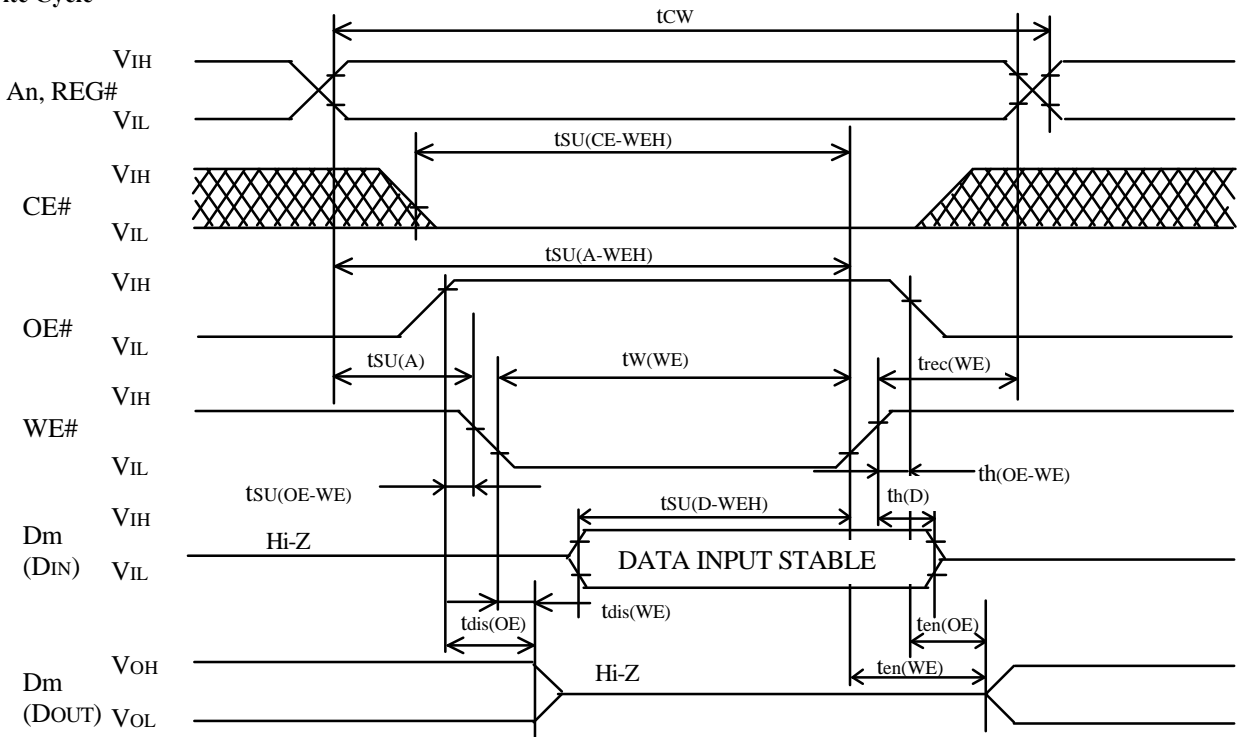

ATA PC CARDS

I/O READ (INPUT) TIMING

Symbol	Parameter	Limit		Unit
		Min	Max	
td(IORD)	Data Delay after IORD#		100	ns
th(IORD)	Data Hold following IORD#	0		ns
twIORD	IORD# Width Time	165		ns
tsu A(IORD)	Address Setup before IORD#	70		ns
th A(IORD)	Address Hold following IORD#	20		ns
tsu CE(IORD)	CE# Setup before IORD#	5		ns
th CE(IORD)	CE# Hold following IORD#	20		ns
tsu REG(IORD)	REG# Setup before IORD#	5		ns
th REG(IORD)	REG# Hold following IORD#	0		ns
tdf INPACK(IORD)	INPACK# Delay Falling from IORD#	0	45	ns
tdr INPACK(IORD)	INPACK# Delay Rising from IORD#		45	ns
tdf IOIS16(ADR)	IOIS16# Delay Falling from Address		35	ns
tdr IOIS16(ADR)	IOIS16# Delay Rising from Address		35	ns
tdf WT(IORD)	WAIT# Delay Falling from IORD#		35	ns
tdr(WT)	Data Delay from WAIT# Rising		0	ns
tw(WT)	WAIT# Width Time		350	ns

The maximum load on **WAIT#**, **INPACK#** and **IOIS16#** are 1 LSTTL with 50 pF total load.

I/O WRITE (OUTPUT) TIMING

Symbol	Parameter	Limit		Unit
		Min	Max	
td(IOWR)	Data Setup before IOWR#	60		ns
th(IOWR)	Data Hold following IOWR#	30		ns
twIOWR	IOWR# Width Time	165		ns
tsu A((IOWR)	Address Setup before IOWR#	70		ns
th A((IOWR)	Address Hold following IOWR#	20		ns
tsu CE((IOWR)	CE# Setup before IOWR#	5		ns
th CE((IOWR)	CE# Hold following IOWR#	20		ns
tsu REG(IOWR)	REG# Setup before IOWR#	5		ns
th REG((IOWR)	REG# Hold following IOWR#	0		ns
tdf IOIS16(ADR)	IOIS16# Delay Falling from Address		35	ns
rd r IOIS16(ADR)	IOIS16# Delay Rising from Address		35	ns
tdf WT(IOWR)	WAIT# Delay Falling from IOWR#		35	ns
tw(WT)	WAIT# Width Time		350	ns
tdr IOWR(WT)	IOWR# high from WAIT# High	0		ns

The maximum load on **WAIT#**, **INPACK#** and **IOIS16#** are 1 LSTTL with 50 pF total load.

I/O READ (INPUT) TIMING DIAGRAM

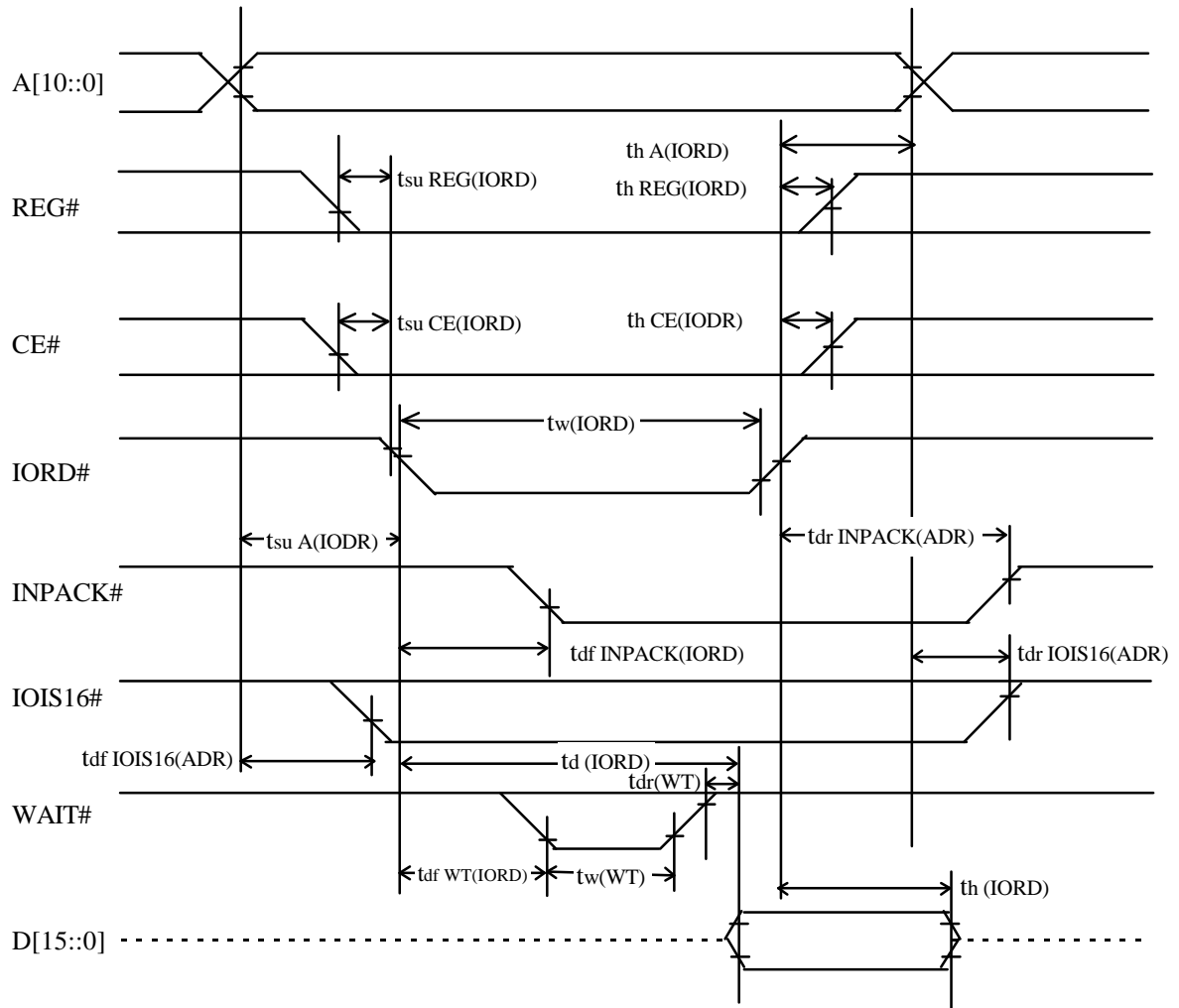

I/O WRITE (OUTPUT) TIMING DIAGRAM

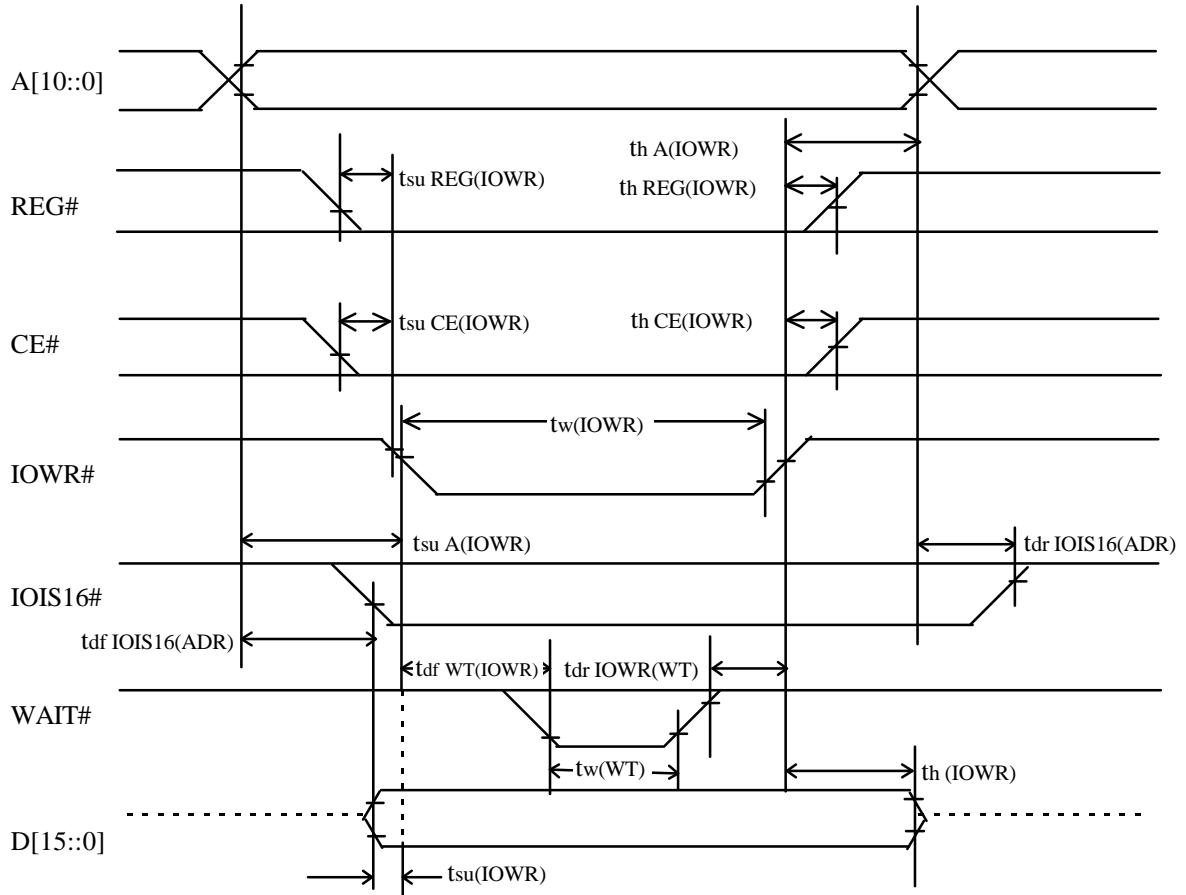

RECOMMENDED POWER UP/DOWN CONDITIONS (Ta=0~60°C, unless otherwise noted)

Symbol	Parameter	Conditions	Limits			Unit
			Min.	Typ.	Max.	
Vi(CE)	CE input voltage	$0V \leq V_{CC} < 2V$	0		V_{CC}	V
		$2V \leq V_{CC} < V_{IH}$	$V_{CC}-0.1$	V_{CC}	$V_{CC}+0.1$	V
		$V_{IH} \leq V_{CC}$	V_{IH}		$V_{CC}+0.1$	V
tsu(Vcc)	CE setup time		20			ms
tsu(RESET)	RESET setup time		20			ms
trec(Vcc)	CE recover time		1			μs
tpr	Vcc rising time	10% → 90% of Vcc	0.1		100	ms
tpf	Vcc falling time	90% of Vcc → 10%	3		300	ms
tw(RESET)	RESET width		10			μs
th(Hi-zRESET)			1			ms
ts(Hi-zRESET)			0			ms

POWER UP/DOWN TIMING DIAGRAM

