

M54677FP

2-PHASE STEPPER MOTOR DRIVER

DESCRIPTION

The M54677FP is a semiconductor IC to drive a bipolar stepper motor directly by controlling the coil current with the constant current method.

FEATURES

- Wide output current control range (20 – 1000mA)
- Bipolar and constant current
- Built in a thermal shutdown circuit
- Built in flywheel diodes

APPLICATION

Office automation equipment such as printer, FDD, HDD, and FAX

FUNCTION

The M54677FP can drive a stepper motor by the 2-phase bipolar method and also control the coil current. Furthermore, it controls the direction of the coil current by Ph input and the coil current value by Vref pin.

Because two control circuits are built in this IC, a stepper motor can be driven with a single IC by the 2-phase bipolar method.

PIN CONFIGURATION (TOP VIEW)

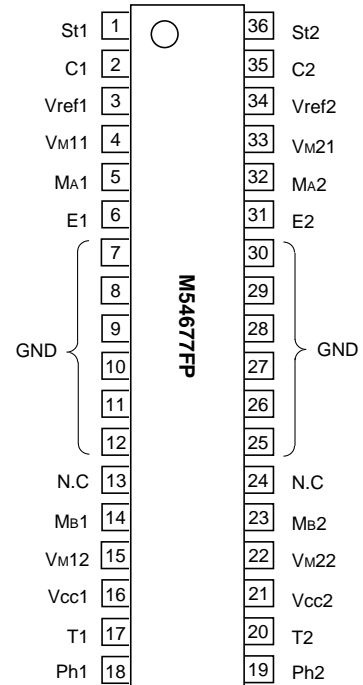

Outline 36P2R-D

N.C: no connection

BLOCK DIAGRAM

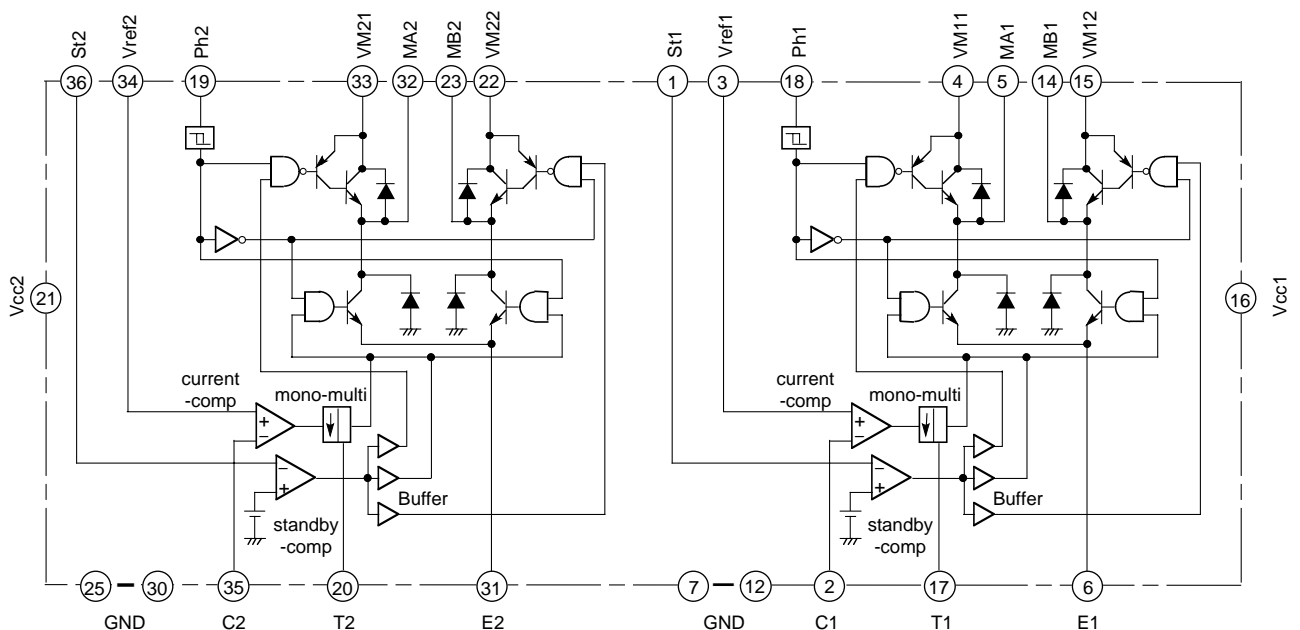

ABSOLUTE MAXIMUM RATINGS (Ta=25°C, unless otherwise noted)

Symbol	Parameter	Conditions	Ratings	Unit
Vcc	Supply voltage	Pins ⑩ and ⑪	-0.3 – 7	V
VM	Output supply voltage	Pins ④ ⑮ ⑳ and ㉑	-0.3 – 28	V
VL	Logic input voltage	Pins ① ⑯ ⑰ and ⑱	-0.3 – 6	V
Vc	Analog input voltage	Pins ② and ⑳	-0.3 – Vcc	V
Vref	Comparative input voltage	Pins ③ and ㉒	-0.3 – Vcc	V
Io	Output current		1500	mA
Pd	Allowable loss	Mounted on a glass epoxy board (100mm x 100mm, t=1.6mm)	2.0	W
Kθ	Thermal derating	Mounted on a glass epoxy board (100mm x 100mm, t=1.6mm)	62.5	°C/W
Tj	Junction temperature		150	°C
Topr	Operating temperature		-20 – 75	°C
Tstg	Storage temperature		-40 – 125	°C

RECOMMENDED OPERATING CONDITIONS

Symbol	Parameter	Limits			Unit
		Min.	Typ.	Max.	
Vcc	Small-signal supply voltage	4.5	5.0	5.5	V
VM	Output supply voltage	10		26.5	V
Io	Output current		500	1000	mA
tPLH	Logic input rise time			2	μS
tPHL	Logic input fall time			2	μS
Ton	Thermal shutdown temperature		160		°C

ELECTRICAL CHARACTERISTICS (Ta=25°C, Vcc=5V, VM=24V, unless otherwise noted)

Symbol	Parameter	Test conditions	Limits			Unit
			Min.	Typ.	Max.	
VIH	Logic input voltage (St pin)	Vcc=5V	"H"	2.0	Vcc	V
VIL			"L"	0	0.6	V
VIH	Logic input voltage (Ph pin)	Vcc=5V	"H"	2.0	Vcc	V
VIL			"L"	0	0.8	V
VCH	Comparator input offset voltage	Vref = 500mV	-4	2	8	mV
IC	Comparator input current	C pin input current (C=0V, Vref=500mV)	-20	-5		μA
VC	Comparator input voltage range		0		1.5	V
Iref	Vref input current	Vref pin input current (Vref=0V, C=500mV)	-20	-5		μA
Vref	Vref input voltage range		0		1.5	V
IOFF	Output cutoff current				100	μA
Vsat	Saturation voltage	Voltage at sensing resistor is not included. Io=0.5A		1.3	1.8	V
tOFF	Cutoff time		5	27	50	μS
td	Output turnoff delay			1.6	2.0	μS
Icc1	Supply current	Pin ⑩ current (16Pin=5V)		27	40	mA
Icc2		Pin ⑪ current (21Pin=5V)		26	39	mA
IIH	Logic input current (St pin)	"H"	Vin = 5V		10	μA
IIL		"L"	Vin = 0V	-200		μA
IIH	Logic input current (Ph pin)	"H"	Vin = 5V		10	μA
IIL		"L"	Vin = 0V	-200		μA

SWITCHING CHARACTERISTICS

Switching waveforms

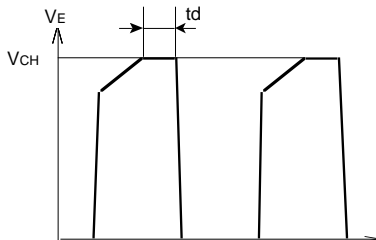
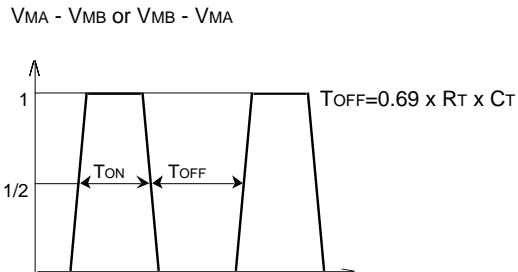

TIMING CHART

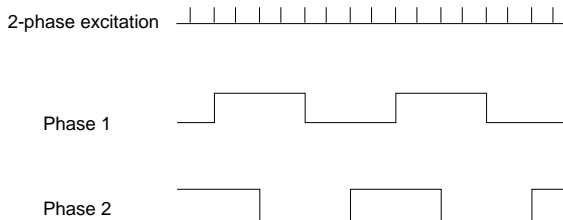

APPLICATION DESCRIPTION

(1) Phase input

Phase input decides the output mode.

Ph	St	MA	MB
H	L	H	L
L	L	L	H
H	H	Z	Z
L	H	Z	Z

Z: High impedance

(2) Vref (Comparative voltage)

The current level can be continuously changed by changing Vref voltage continuously.

(3) Current sensor

When the voltage fall at the current sensing resistor and the selected current level become of the same level, the comparator triggers the monostable. Then the output stage is cut off for a certain time (TOFF). During this cutoff time, the current decreases slightly and falls short of the comparative level.

After the cutoff time (TOFF), the output stage is in ON state again. This operation is repeated.

(4) Single pulse generator

At the comparator output fall edge, the monostable is triggered. The pulse width of the monostable at the external timing CT and RT is as follows.

$$T_{OFF} = 0.69 \times C_T \times R_T$$

Retrigger during TOFF is neglected.

(5) Analog control

The output current level can be continuously changed by changing the voltage at VR or the feedback voltage to the comparator.

TYPICAL CHARACTERISTICS

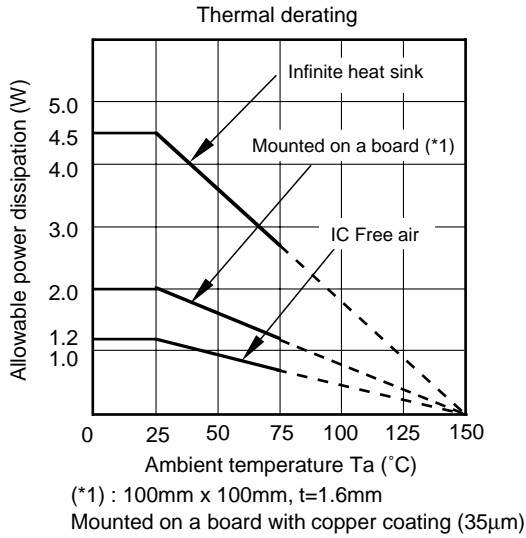

APPLICATION EXAMPLE

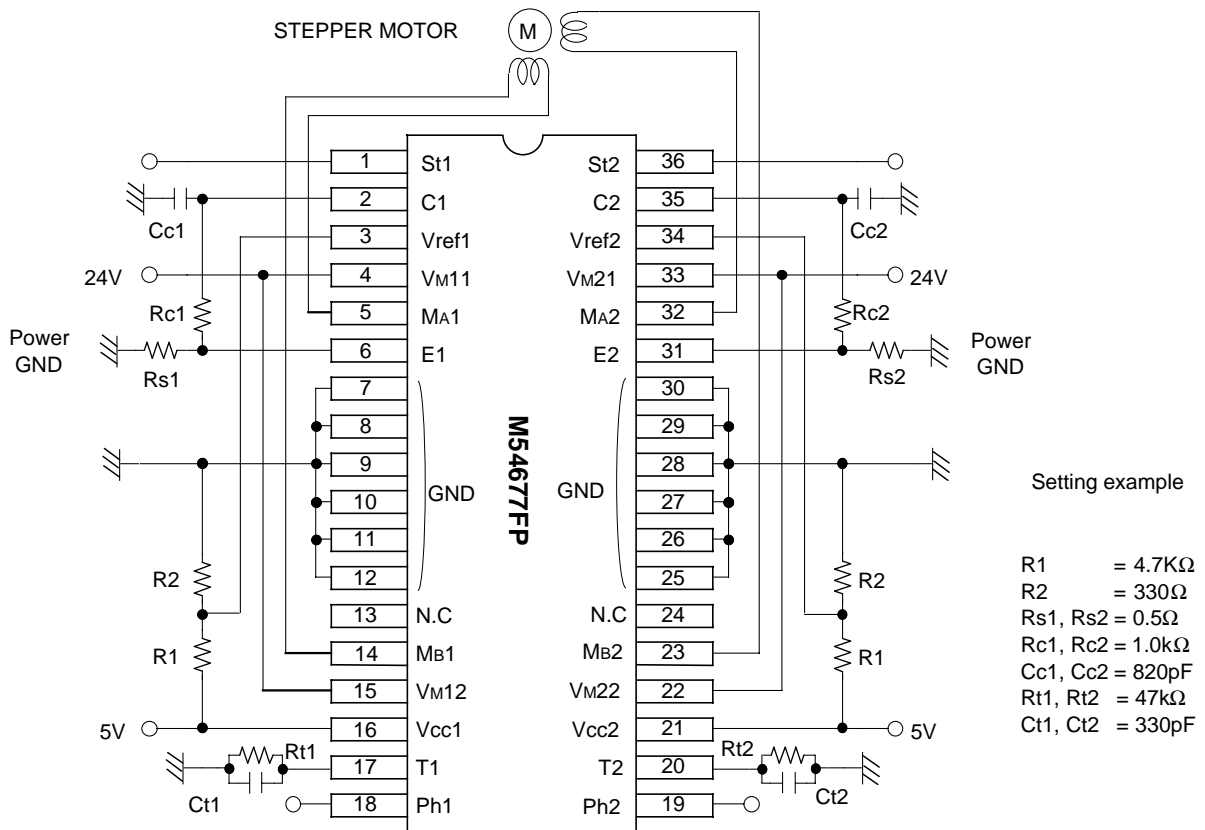

PRECAUTIONS FOR USE

- (1) Before use, never forget to short-circuit Vcc1 and Vcc2.
 - (2) When the whole output current changes by a large margin (for example, when thermal shutdown operation causes intermittent flow of output current), the supply voltage may undergo a change. Therefore, selection and wiring of power supply should be conducted cautiously to avoid such a situation that the supply voltage exceeds the absolute maximum ratings.
 - (3) When the supply voltage changes by a large margin, the operation of this IC may become unstable. In this case, the change of supply voltage can be controlled by connecting a capacitor between Vcc pin and GND pin.
 - (4) Thermal shutdown function
The state of thermal shutdown operation may differ according to the way of wiring within a board. Therefore, sufficient board evaluation should be conducted before use. When the board is changed, operation on the replacing board should be evaluated. The circuit board on which this IC is mounted is designed to realize low impedance between power supply and output pin. Therefore, it is desirable to take a safe measure such as fixing a fuse to avoid such a situation that the board is damaged by a fire when output pin is internally short-circuited by excessive surge voltage applied externally by accident.
-