

MITSUBISHI LSIs M5M5V4R01J-12,-15

1997.11.20 Rev.F

4194304-BIT (4194304-WORD BY 1-BIT) CMOS STATIC RAM

DESCRIPTION

The M5M5V4R01J is a family of 4194304-word by 1-bit static RAMs, fabricated with the high performance CMOS silicon gate process and designed for high speed application.

The M5M5V4R01J is offered in a 32-pin plastic small outline J-lead package(SOJ).

These device operate on a single 3.3V supply, and are directly TTL compatible. They include a power down feature as well.

FEATURES

- Fast access time M5M5V4R01J-12 •••• 12ns(max)
M5M5V4R01J-15 •••• 15ns(max)
- Low power dissipation Active •••••••• 297mW(typ)
Stand by •••••••• 3.3mW(typ)
- Single +3.3V power supply
- Fully static operation : No clocks, No refresh
- Test mode is available
- Easy memory expansion by \bar{S}
- Three-state outputs : OR-tie capability
- \overline{OE} prevents data contention in the I/O bus
- Directly TTL compatible : All inputs and outputs

PIN CONFIGURATION (TOP VIEW)

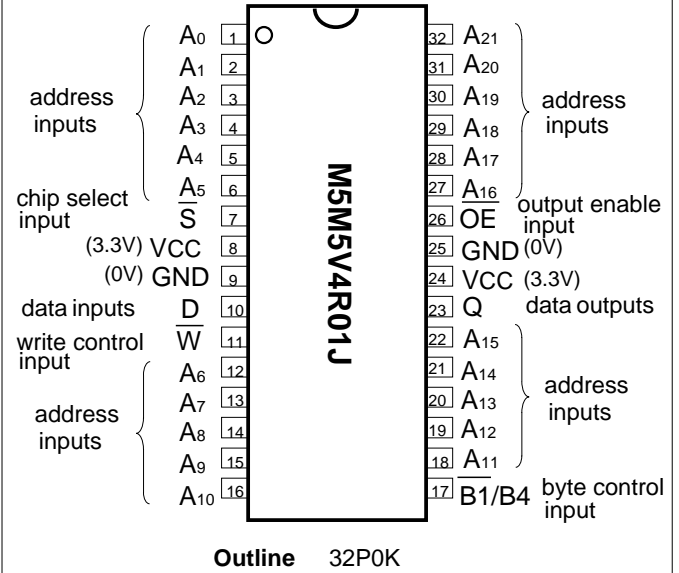

APPLICATION

High-speed memory units

PACKAGE

32pin 400mil SOJ

BLOCK DIAGRAM

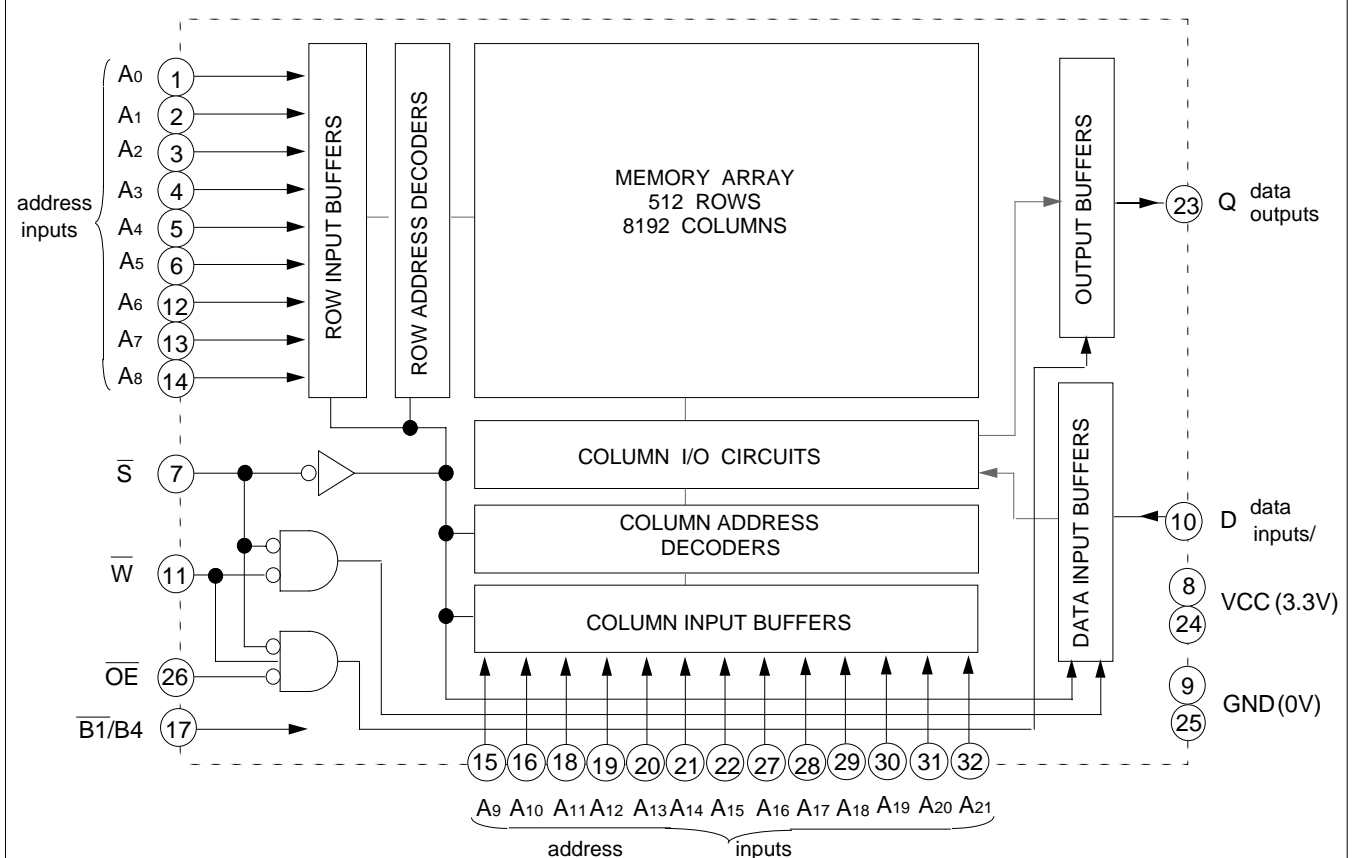

4194304-BIT (4194304-WORD BY 1-BIT) CMOS STATIC RAM

FUNCTION

The operation mode of the M5M5V4R01J is determined by a combination of the device control inputs \overline{S} , \overline{W} and \overline{OE} . Each mode is summarized in the function table.

A write cycle is executed whenever the low level \overline{W} overlaps with the low level \overline{S} . The address must be set-up before the write cycle and must be stable during the entire cycle.

The data is latched into a cell on the trailing edge of \overline{W} or \overline{S} , whichever occurs first, requiring the set-up and hold time relative to these edge to be maintained. The output enable input \overline{OE} directly controls the output stage. Setting the \overline{OE} at a high level, the output stage is in a high impedance state, and the data bus contention problem in the write cycle is eliminated.

A read cycle is executed by setting \overline{W} at a high level and \overline{OE} at a low level while \overline{S} are in an active state ($\overline{S}=L$).

When setting \overline{S} at high level, the chip is in a non-selectable mode in which both reading and writing are disabled. In this mode, the output stage is in a high-impedance state, allowing OR-tie with other chips and memory expansion by \overline{S} .

Signal \overline{S} controls the power-down feature. When \overline{S} goes high, power dissipation is reduced extremely. The access time from \overline{S} is equivalent to the address access time.

The RAM works with an organization of 4194304-word by 1 bit, when $\overline{B1}/B4$ is low or floating. And an organization of 10485 76-word by 4bit is also obtained for reducing the test time, when $\overline{B1}/B4$ is high.

FUNCTION TABLE

\overline{S}	\overline{W}	\overline{OE}	Mode	D	Q	I _{cc}
H	X	X	Non selection	High-impedance	High-impedance	Stand by
L	L	X	Write	Din	High-impedance	Active
L	H	L	Read	High-impedance	Dout	Active
L	H	H		High-impedance	High-impedance	Active

ABSOLUTE MAXIMUM RATINGS

Symbol	Parameter	Conditions	Ratings	Unit
V _{cc}	Supply voltage	With respect to GND	-2.0* ~ 4.6	V
V _I	Input voltage		-2.0* ~ V _{CC} +0.5	V
V _O	Output voltage		-2.0* ~ V _{CC} +0.5	V
P _d	Power dissipation	T _a =25 °C	1000	mW
T _{opr}	Operating temperature		0 ~ 70	°C
T _{stg(bias)}	Storage temperature (bias)		-10 ~ 85	°C
T _{stg}	Storage temperature		-65 ~ 150	°C

*Pulse width ≤ 20ns, In case of DC:-0.5V

DC ELECTRICAL CHARACTERISTICS (T_a=0 ~ 70 °C, V_{cc}=3.3V ^{+10%}/_{-5%} unless otherwise noted)

Symbol	Parameter	Condition	Limits			Unit	
			Min	Typ	Max		
V _{IH}	High-level input voltage		2.2		V _{cc} +0.3	V	
V _{IL}	Low-level input voltage		-0.3		0.8	V	
V _{OH}	High-level output voltage	I _{OH} = -4mA	2.0			V	
V _{OL}	Low-level output voltage	I _{OL} = 8mA			0.4	V	
I _I	Input current	V _I = 0~V _{cc}			2	μA	
I _{OZ}	Output current in off-state	V _I (\overline{S})= V _{IH} V _O = 0~V _{cc}			10	μA	
I _{CC1}	Active supply current (TTL level)	V _I (\overline{S})= V _{IL} other inputs V _{IH} or V _{IL} Output-open(duty 100%)	AC	12ns cycle		160	mA
				15ns cycle		150	
I _{CC2}	Stand by current (TTL level)	V _I (\overline{S})= V _{IH}	AC	12ns cycle		75	mA
				15ns cycle		70	
			DC			90	
I _{CC3}	Stand by current	V _I (\overline{S})= V _{cc} ≥0.2V other inputs V _I ≤0.2V or V _I ≥V _{cc} -0.2V				1	mA
						10	

CAPACITANCE ($T_a=0 \sim 70 \text{ }^\circ\text{C}$, $V_{cc}=3.3\text{V}$ $^{+10\%}_{-5\%}$ unless otherwise noted)

Symbol	Parameter	Test Condition	Limit			Unit
			Min	Typ	Max	
C _i	Input capacitance	$V_I = \text{GND}, V_I = 25\text{mVrms}, f=1\text{MHz}$			8	pF
C _o	Output capacitance	$V_O = \text{GND}, V_O = 25\text{mVrms}, f=1\text{MHz}$			8	pF

Note 1: Direction for current flowing into an IC is positive (no mark).
 2: Typical value is $V_{cc}=5\text{V}, T_a=25 \text{ }^\circ\text{C}$
 3: C_i,C_o are periodically sampled and are not 100% tested.

AC ELECTRICAL CHARACTERISTICS ($T_a=0 \sim 70 \text{ }^\circ\text{C}$, $V_{cc}=3.3\text{V}$ $^{+10\%}_{-5\%}$ unless otherwise noted)

(1)MEASUREMENT CONDITION

- Input pulse levels $V_{IH}=3.0\text{V}, V_{IL}=0.0\text{V}$
- Input rise and fall time 3ns
- Input timing reference levels $V_{IH}=1.5\text{V}, V_{IL}=1.5\text{V}$
- Output timing reference levels $V_{OH}=1.5\text{V}, V_{OL}=1.5\text{V}$
- Output loads Fig1 ,Fig2

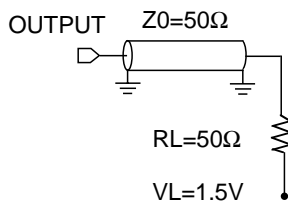

Fig.1 Output load

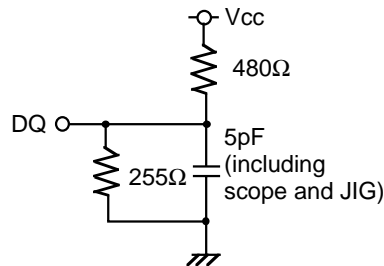

Fig.2 Output load for t_{en}, t_{dis}

(2)READ CYCLE

Symbol	Parameter	Limits				Unit
		M5M5V4R01J -12		M5M5V4R01J -15		
		Min	Max	Min	Max	
t _{CR}	Read cycle time	12		15		ns
t _{a(A)}	Address access time		12		15	ns
t _{a(S)}	Chip select access time		12		15	ns
t _{a(OE)}	Output enable access time		6		8	ns
t _{dis(S)}	Output disable time after \overline{S} high	0	6	0	7	ns
t _{dis(OE)}	Output disable time after \overline{OE} high	0	6	0	7	ns
t _{en(S)}	Output enable time after \overline{S} low	0		0		ns
t _{en(OE)}	Output enable time after \overline{OE} low	0		0		ns
t _{v(A)}	Data valid time after address change	3		3		ns
t _{PU}	Power-up time after chip selection	0		0		ns
t _{PD}	Power-down time after chip selection		12		15	ns

(3)WRITE CYCLE

Symbol	Parameter	Limits				Unit
		M5M5V4R01J -12		M5M5V4R01J -15		
		Min	Max	Min	Max	
t _{cw}	Write cycle time	12		15		ns
t _{w(W)}	Write pulse width	10		12		ns
t _{su(A)1}	Address setup time(\overline{W})	0		0		ns
t _{su(A)2}	Address setup time(\overline{S})	0		0		ns
t _{su(S)}	Chip select setup time	10		12		ns
t _{su(D)}	Data setup time	6		7		ns
t _{h(D)}	Data hold time	0		0		ns
t _{rec(W)}	Write recovery time	1		1		ns
t _{dis(W)}	Output disable time after \overline{W} low	0	6	0	7	ns
t _{dis(OE)}	Output disable time after \overline{OE} high	0	6	0	7	ns
t _{en(W)}	Output enable time after \overline{W} high	0		0		ns
t _{en(OE)}	Output enable time after \overline{OE} low	0		0		ns
t _{su(A-WH)}	Address to \overline{W} High	10		12		ns

(4)TIMING DIAGRAMS

Read cycle 1

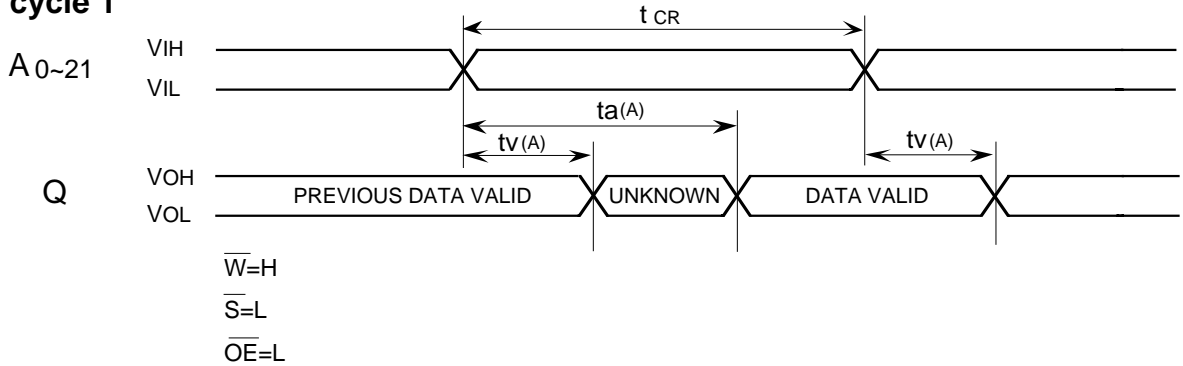

Read cycle 2 (Note 4)

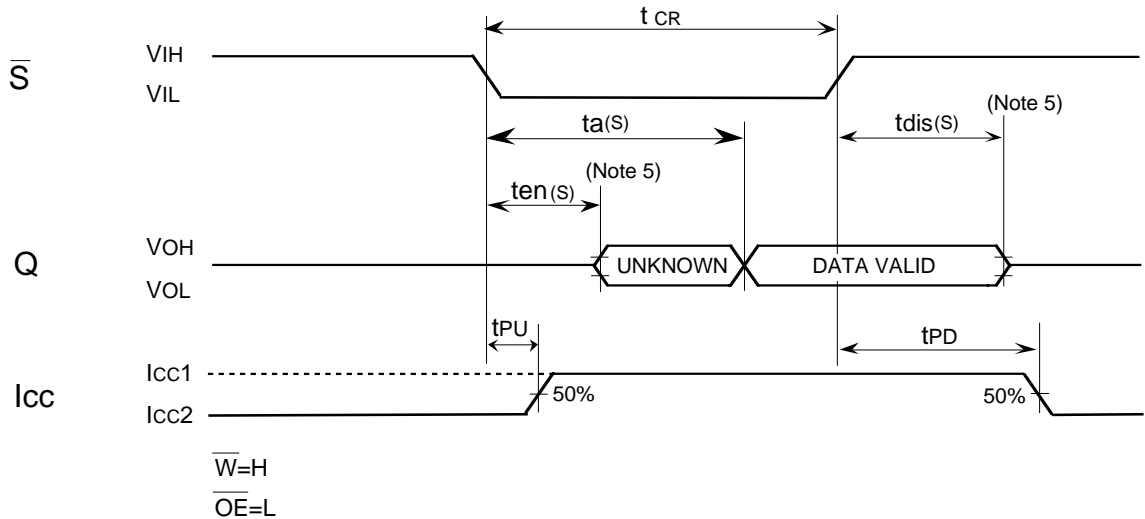

Note 4. Addresses valid prior to or coincident with \overline{S} transition low.

5. Transition is measured $\pm 500\text{mV}$ from steady state voltage with specified loading in Figure 2.

Read cycle 3 (Note 6)

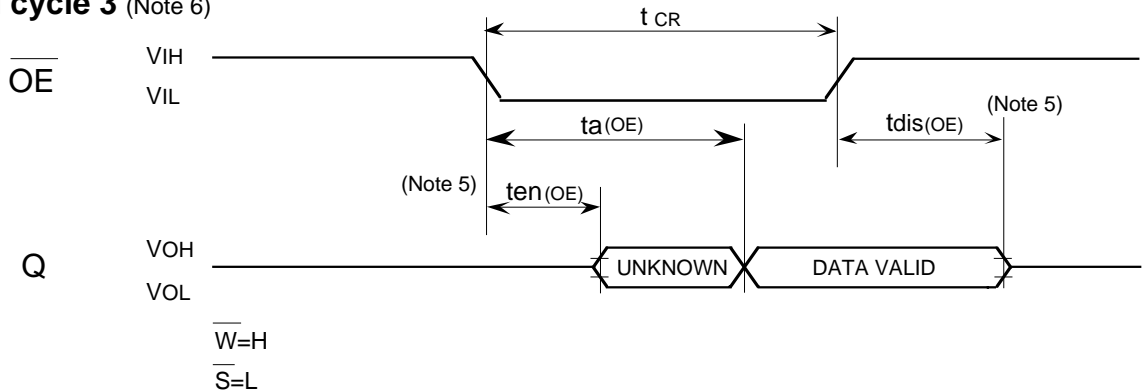

Note 6. Addresses and \overline{S} valid prior to \overline{OE} transition low by $(t_{a(A)} - t_{a(OE)})$, $(t_{a(S)} - t_{a(OE)})$

Write cycle (\overline{W} control mode)

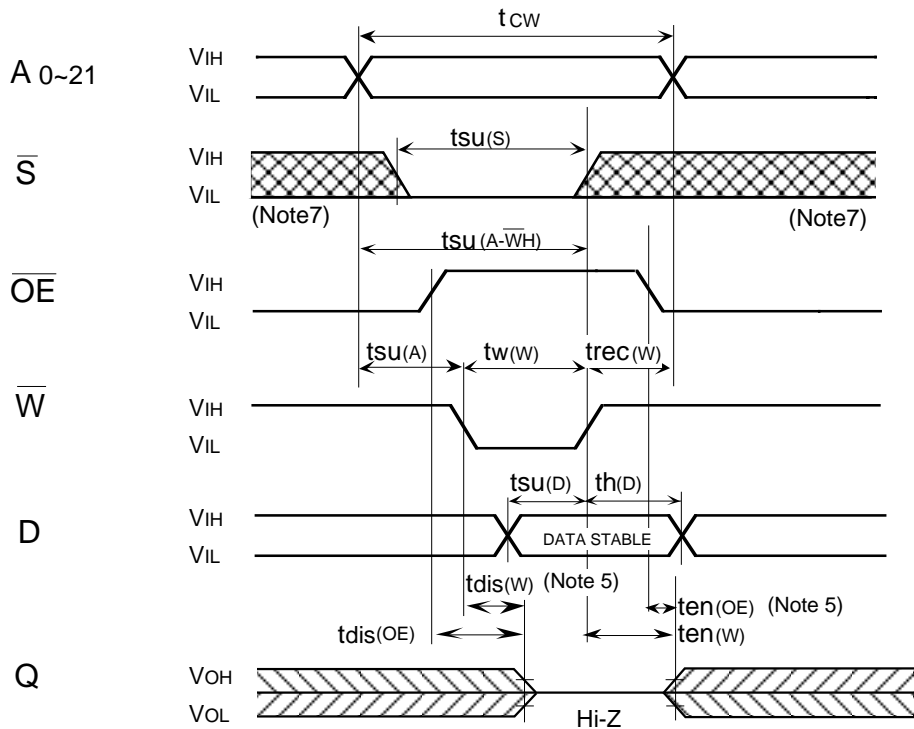

Write cycle (\overline{S} control mode)

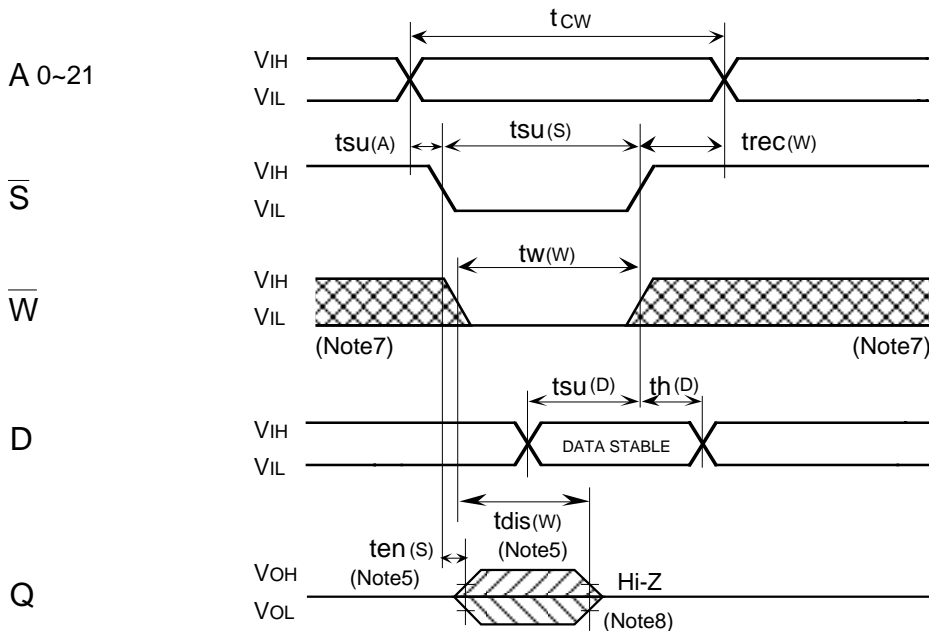

Note 7: Hatching indicates the state is don't care.

8: When the falling edge of \overline{W} is simultaneous or prior to the falling edge of \overline{S} , the output is maintained in the high impedance.

9: t_{en} , t_{dis} are periodically sampled and are not 100% tested.