

PRELIMINARY
 Notice: This is not a final specification.
 Some parametric limits are subject to change.

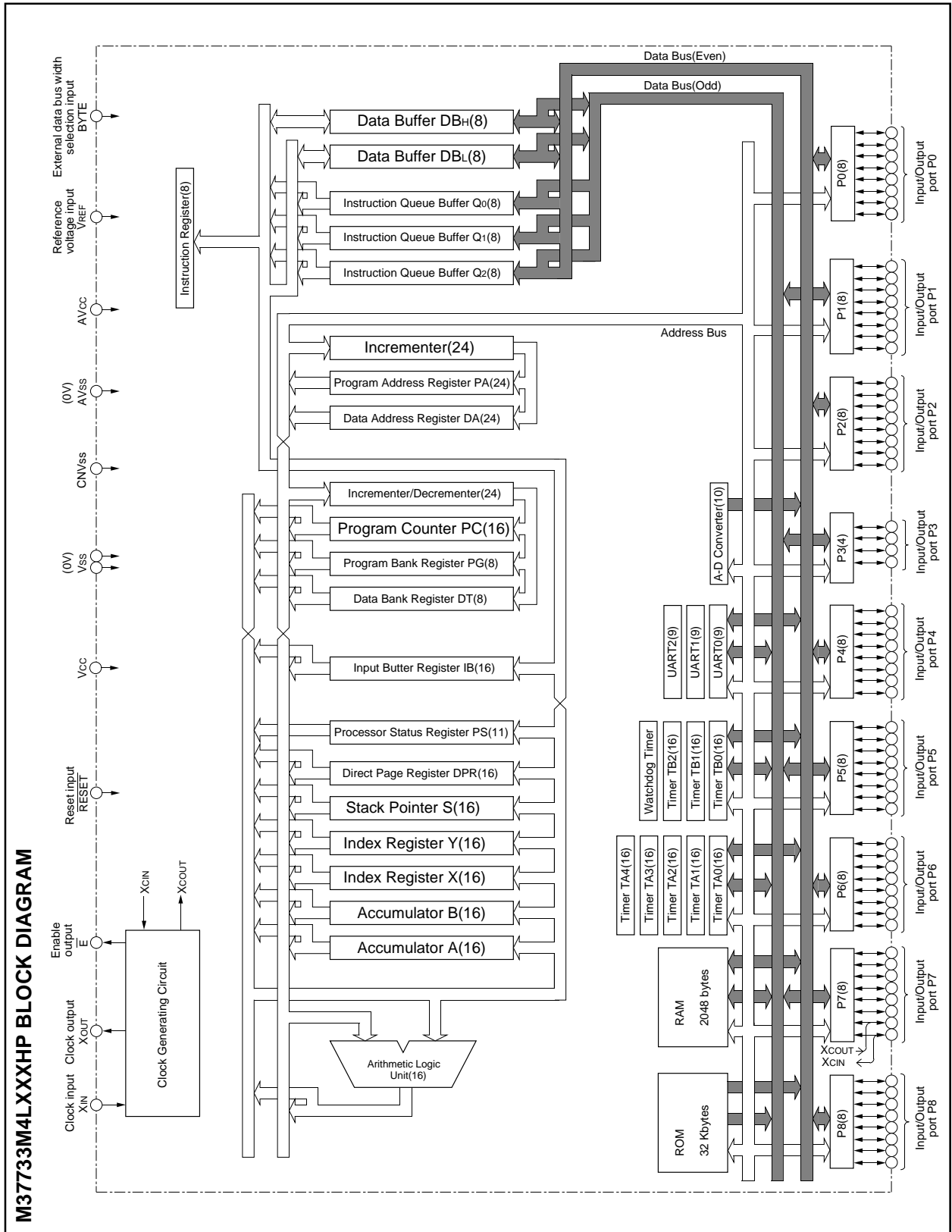

PRELIMINARY
 Notice: This is not a final specification.
 Some parametric limits are subject to change.

MITSUBISHI MICROCOMPUTERS
M37733M4LXXXHP

SINGLE-CHIP 16-BIT CMOS MICROCOMPUTER

FUNCTIONS OF M37733M4LXXXHP

Parameter		Functions
Number of basic instructions		103
Instruction execution time		333 ns (the fastest instruction at external clock 12 MHz frequency)
Memory size	ROM	32 Kbytes
	RAM	2048 bytes
Input/Output ports	P0 – P2, P4 – P8	8-bit X 8
	P3	4-bit X 1
Multi-function timers	TA0, TA1, TA2, TA3, TA4	16-bit X 5
	TB0, TB1, TB2	16-bit X 3
Serial I/O		(UART or clock synchronous serial I/O) X 3
A-D converter		10-bit X 1 (8 channels)
Watchdog timer		12-bit X 1
Interrupts		3 external types, 16 internal types Each interrupt can be set to the priority level (0 – 7.)
Clock generating circuit		2 circuits built-in (externally connected to a ceramic resonator or a quartz-crystal oscillator)
Supply voltage		2.7 – 5.5 V
Power dissipation		9 mW (at 3 V supply voltage, external clock 12 MHz frequency) 22.5 mW (at 5 V supply voltage, external clock 12 MHz frequency)
Input/Output characteristic	Input/Output voltage	5 V
	Output current	5 mA
Memory expansion		Maximum 16 Mbytes
Operating temperature range		–40 to 85 °C
Device structure		CMOS high-performance silicon gate process
Package		80-pin plastic molded fine-pitch QFP (80P6D-A;0.5 mm lead pitch)

PRELIMINARY
 Notice: This is not a final specification.
 Some parametric limits are subject to change.

mitsubishi MICROCOMPUTERS
M37733M4LXXXHP

SINGLE-CHIP 16-BIT CMOS MICROCOMPUTER

PIN DESCRIPTION

Pin	Name	Input/Output	Functions
V _{cc} , V _{ss}	Power source		Apply 2.7 – 5.5 V to V _{cc} and 0 V to V _{ss} .
CNV _{ss}	CNV _{ss} input	Input	This pin controls the processor mode. Connect to V _{ss} for the single-chip mode and the memory expansion mode, and to V _{cc} for the microprocessor mode.
RESET	Reset input	Input	When "L" level is applied to this pin, the microcomputer enters the reset state.
X _{IN}	Clock input	Input	These are pins of main-clock generating circuit. Connect a ceramic resonator or a quartz-crystal oscillator between X _{IN} and X _{OUT} . When an external clock is used, the clock source should be connected to the X _{IN} pin, and the X _{OUT} pin should be left open.
X _{OUT}	Clock output	Output	
\bar{E}	Enable output	Output	This pin functions as the enable signal output pin which indicates the access status in the internal bus. When output level of \bar{E} signal is "L", data/instruction read or data write is performed.
BYTE	External data bus width selection input	Input	In the memory expansion mode or the microprocessor mode, this pin determines whether the external data bus has an 8-bit width or a 16-bit width. The data bus has a 16-bit width when "L" signal is input and an 8-bit width when "H" signal is input.
AV _{cc} , AV _{ss}	Analog power source input		Power source input pin for the A-D converter. Externally connect AV _{cc} to V _{cc} and AV _{ss} to V _{ss} .
V _{REF}	Reference voltage input	Input	This is reference voltage input pin for the A-D converter.
P ₀₀ – P ₀₇	I/O port P0	I/O	In the single-chip mode, port P0 becomes an 8-bit I/O port. An I/O direction register is available so that each pin can be programmed for input or output. These ports are in the input mode when reset. In the memory expansion mode or the microprocessor mode, these pins output address (A ₀ – A ₇).
P ₁₀ – P ₁₇	I/O port P1	I/O	In the single-chip mode, these pins have the same functions as port P0. When the BYTE pin is set to "L" in the memory expansion mode or the microprocessor mode and external data bus has a 16-bit width, high-order data (D ₈ – D ₁₅) is input/output or an address (A ₈ – A ₁₅) is output. When the BYTE pin is "H" and an external data bus has an 8-bit width, only address (A ₈ – A ₁₅) is output.
P ₂₀ – P ₂₇	I/O port P2	I/O	In the single-chip mode, these pins have the same functions as port P0. In the memory expansion mode or the microprocessor mode, low-order data (D ₀ – D ₇) is input/output or an address (A ₁₆ – A ₂₃) is output.
P ₃₀ – P ₃₃	I/O port P3	I/O	In the single-chip mode, these pins have the same function as port P0. In the memory expansion mode or the microprocessor mode, R/W, BHE, ALE, and HLDA signals are output.
P ₄₀ – P ₄₇	I/O port P4	I/O	In the single-chip mode, these pins have the same functions as port P0. In the memory expansion mode or the microprocessor mode, P ₄₀ , P ₄₁ , and P ₄₂ become HOLD and RDY input pins, and clock ϕ_1 output pin, respectively. Functions of the other pins are the same as in the single-chip mode. However, in the memory expansion mode, P ₄₂ also functions as an I/O port.
P ₅₀ – P ₅₇	I/O port P5	I/O	In addition to having the same functions as port P0 in the single-chip mode, these pins also function as I/O pins for timers A0 to A3 and input pins for key input interrupt input (KI ₀ – KI ₃).
P ₆₀ – P ₆₇	I/O port P6	I/O	In addition to having the same functions as port P0 in the single-chip mode, these pins also function as I/O pins for timer A4, input pins for external interrupt input (INT ₀ – INT ₂) and input pins for timers B0 to B2. P ₆₇ also functions as sub-clock ϕ_{SUB} output pin.
P ₇₀ – P ₇₇	I/O port P7	I/O	In addition to having the same functions as port P0 in the single-chip mode, these pins function as input pins for A-D converter. P ₇₂ to P ₇₅ also function as I/O pins for UART2. Additionally, P ₇₆ and P ₇₇ have the function as the output pin (XC _{OUT}) and the input pin (XC _{IN}) of the sub-clock (32 kHz) oscillation circuit, respectively. When P ₇₆ and P ₇₇ are used as the XC _{OUT} and XC _{IN} pins, connect a resonator or an oscillator between the both.
P ₈₀ – P ₈₇	I/O port P8	I/O	In addition to having the same functions as port P0 in the single-chip mode, these pins also function as I/O pins for UART 0 and UART 1.

PRELIMINARY
 Notice: This is not a final specification.
 Some parametric limits are subject to change.

MITSUBISHI MICROCOMPUTERS
M37733M4LXXXHP

SINGLE-CHIP 16-BIT CMOS MICROCOMPUTER

BASIC FUNCTION BLOCKS

The M37733M4LXXXHP has the same functions as the M37733MHBXXXFP except for the memory allocation, the reset circuit, the ROM area modification function, and the package. Refer to the section on the M37733MHBXXXFP.

MEMORY

The memory map is shown in Figure 1. The address space has a capacity of 16 Mbytes and is allocated to addresses from 0₁₆ to FFFFFFF₁₆. The address space is divided by 64-Kbyte unit called bank. The banks are numbered from 0₁₆ to FF₁₆. Built-in ROM, RAM and control registers for internal peripheral devices are assigned to bank 0₁₆. The 32-Kbyte area from addresses 8000₁₆ to FFFF₁₆ is the built-in ROM. Addresses FFD6₁₆ to FFFF₁₆ are the RESET and interrupt vector addresses and contain the interrupt vectors. Refer to the section on interrupts for details. The 2048-byte area allocated to addresses from 80₁₆ to 87F₁₆ is the built-in RAM. In addition to storing data, the RAM is used as stack during a subroutine call or interrupts.

Peripheral devices such as I/O ports, A-D converter, serial I/O, timer, and interrupt control registers are allocated to addresses from 0₁₆ to 7F₁₆. Additionally, the internal ROM area can be modified by software. Refer to the section on ROM area modification function for details. A 256-byte direct page area can be allocated anywhere in bank 0₁₆ by using the direct page register (DPR). In the direct page addressing mode, the memory in the direct page area can be accessed with two words. Hence program steps can be reduced.

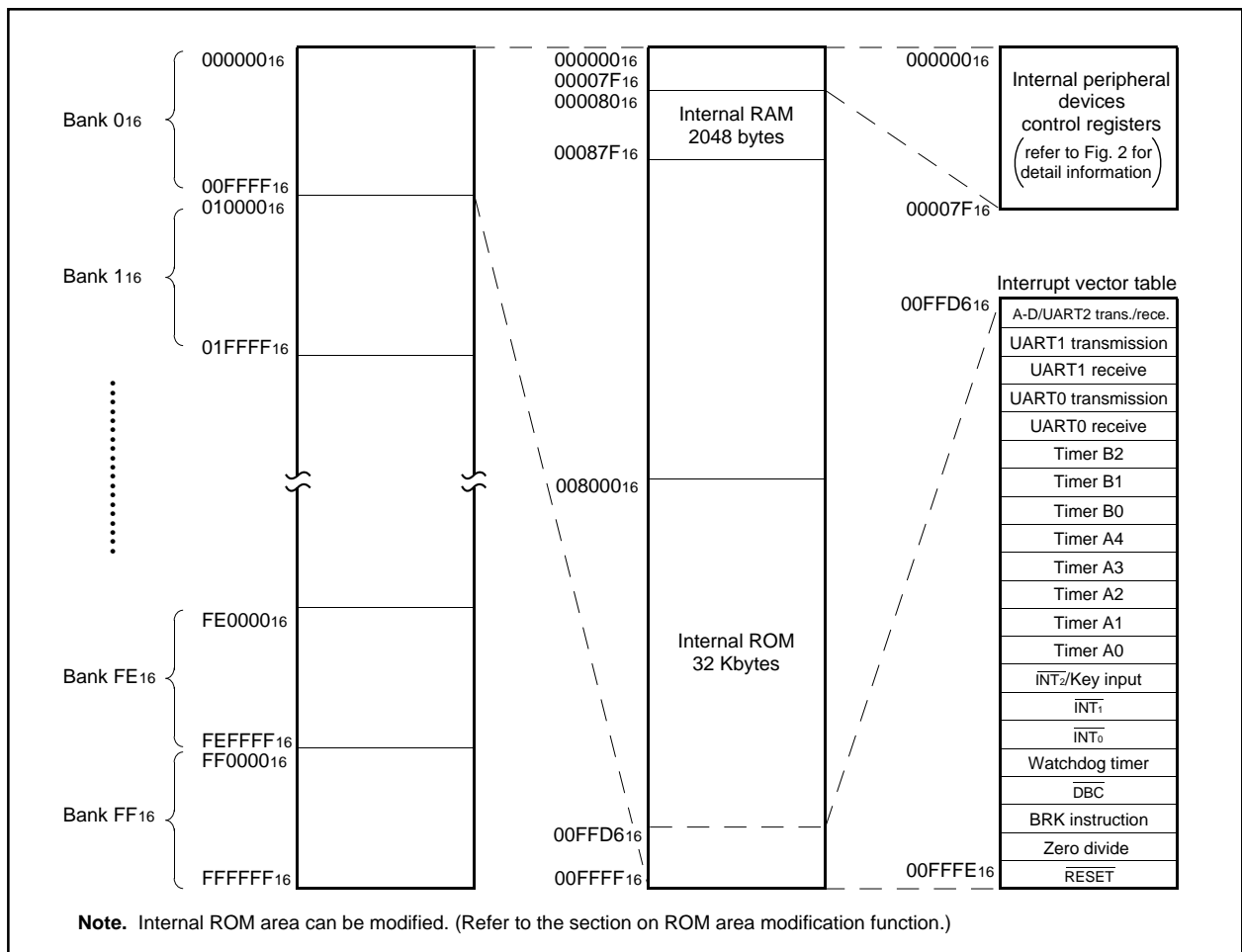

Fig. 1 Memory map

PRELIMINARY
 Notice: This is not a final specification.
 Some parametric limits are subject to change.

MITSUBISHI MICROCOMPUTERS
M37733M4LXXXHP

SINGLE-CHIP 16-BIT CMOS MICROCOMPUTER

Address (Hexadecimal notation)		Address (Hexadecimal notation)	
000000		000040	Count start flag
000001		000041	
000002	Port P0 register	000042	One-shot start flag
000003	Port P1 register	000043	
000004	Port P0 direction register	000044	Up-down flag
000005	Port P1 direction register	000045	
000006	Port P2 register	000046	Timer A0 register
000007	Port P3 register	000047	
000008	Port P2 direction register	000048	Timer A1 register
000009	Port P3 direction register	000049	
00000A	Port P4 register	00004A	Timer A2 register
00000B	Port P5 register	00004B	
00000C	Port P4 direction register	00004C	Timer A3 register
00000D	Port P5 direction register	00004D	
00000E	Port P6 register	00004E	Timer A4 register
00000F	Port P7 register	00004F	
000010	Port P6 direction register	000050	Timer B0 register
000011	Port P7 direction register	000051	
000012	Port P8 register	000052	Timer B1 register
000013		000053	
000014	Port P8 direction register	000054	Timer B2 register
000015		000055	
000016		000056	Timer A0 mode register
000017		000057	Timer A1 mode register
000018		000058	Timer A2 mode register
000019		000059	Timer A3 mode register
00001A		00005A	Timer A4 mode register
00001B		00005B	Timer B0 mode register
00001C	Reserved area (Note)	00005C	Timer B1 mode register
00001D	Reserved area (Note)	00005D	Timer B2 mode register
00001E	A-D control register 0	00005E	Processor mode register 0
00001F	A-D control register 1	00005F	Processor mode register 1
000020	A-D register 0	000060	Watchdog timer register
000021		000061	Watchdog timer frequency selection flag
000022	A-D register 1	000062	Reserved area (Note)
000023		000063	Memory allocation control register
000024	A-D register 2	000064	UART 2 transmit/receive mode register
000025		000065	UART 2 baud rate register
000026	A-D register 3	000066	UART 2 transmission buffer register
000027		000067	
000028	A-D register 4	000068	UART 2 transmit/receive control register 0
000029		000069	UART 2 transmit/receive control register 1
00002A	A-D register 5	00006A	UART 2 receive buffer register
00002B		00006B	
00002C	A-D register 6	00006C	Oscillation circuit control register 0
00002D		00006D	Port function control register
00002E	A-D register 7	00006E	Serial transmit control register
00002F		00006F	Oscillation circuit control register 1
000030	UART 0 transmit/receive mode register	000070	A-D/UART 2 trans./rece. interrupt control register
000031	UART 0 baud rate register	000071	UART 0 transmission interrupt control register
000032	UART 0 transmission buffer register	000072	UART 0 receive interrupt control register
000033		000073	UART 1 transmission interrupt control register
000034	UART 0 transmit/receive control register 0	000074	UART 1 receive interrupt control register
000035	UART 0 transmit/receive control register 1	000075	Timer A0 interrupt control register
000036	UART 0 receive buffer register	000076	Timer A1 interrupt control register
000037		000077	Timer A2 interrupt control register
000038	UART 1 transmit/receive mode register	000078	Timer A3 interrupt control register
000039	UART 1 baud rate register	000079	Timer A4 interrupt control register
00003A	UART 1 transmission buffer register	00007A	Timer B0 interrupt control register
00003B		00007B	Timer B1 interrupt control register
00003C	UART 1 transmit/receive control register 0	00007C	Timer B2 interrupt control register
00003D	UART 1 transmit/receive control register 1	00007D	INT0 interrupt control register
00003E		00007E	INT1 interrupt control register
00003F	UART 1 receive buffer register	00007F	INT2/Key input interrupt control register

Note. Do not write to this address.

Fig. 2 Location of internal peripheral devices and interrupt control registers

RESET CIRCUIT

The microcomputer is released from the reset state when the $\overline{\text{RESET}}$ pin is returned to "H" level after holding it at "L" level with the power source voltage at 2.7 – 5.5 V. Program execution starts at the address formed by setting address $A_{23} - A_{16}$ to 0016, $A_{15} - A_8$ to the contents of address FFFF_{16} , and $A_7 - A_0$ to the contents of address FFFE_{16} . Figure 3 shows an example of a reset circuit. When the stabilized clock is input from the external to the main-clock oscillation circuit, the reset input voltage must be 0.55 V or less when the power source voltage reaches 2.7 V. When a resonator/oscillator is connected to the main-clock oscillation circuit, change the reset input voltage from "L" to "H" after the main-clock oscillation is fully stabilized. The status of the internal registers during reset is the same as the M37733MHBXXXFP's.

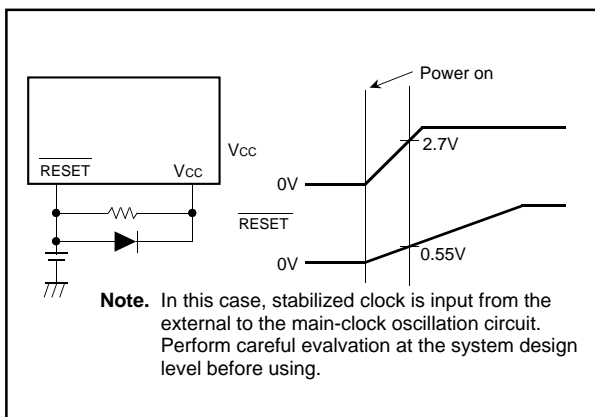

Fig. 3 Example of a reset circuit

ROM AREA MODIFICATION FUNCTION

The internal ROM size and its address area of the M37733M4LXXXHP can be modified by the memory allocation control register's bit 0 shown in Figure 4.

Figure 6 shows the memory allocation in which the internal ROM size and its address area are modified.

Make sure to write data in the memory allocation control register as the flow shown in Figure 5.

This ROM area modification function is valid in memory expansion mode and single-chip mode.

When ordering a mask ROM, Mitsubishi Electric corp. produces the mask ROM using the data within 32 Kbytes (addresses 008000₁₆ – 00FFFF₁₆). It is regardless of the selected ROM size (refer to MASK ROM ORDER CONFIRMATION FORM.) Therefore, program "FF₁₆" to the addresses out of the selected ROM area in the EPROM which you tender when ordering a mask ROM.

Address 00FFFF₁₆ of this microcomputer corresponds to the lowest address of the EPROM which you tender.

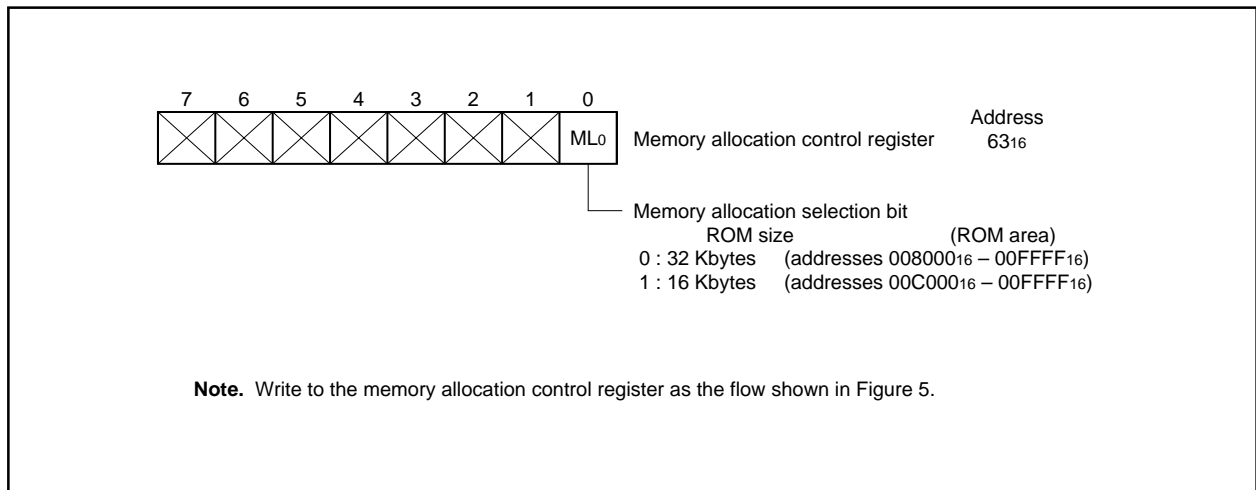

Fig. 4 Bit configuration of memory allocation control register

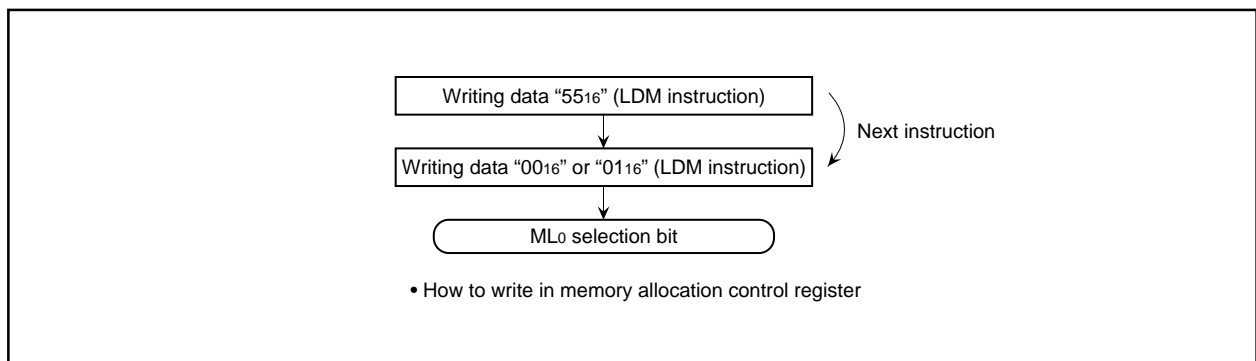

Fig. 5 How to write data in memory allocation control register

PRELIMINARY
 Notice: This is not a final specification.
 Some parametric limits are subject to change.

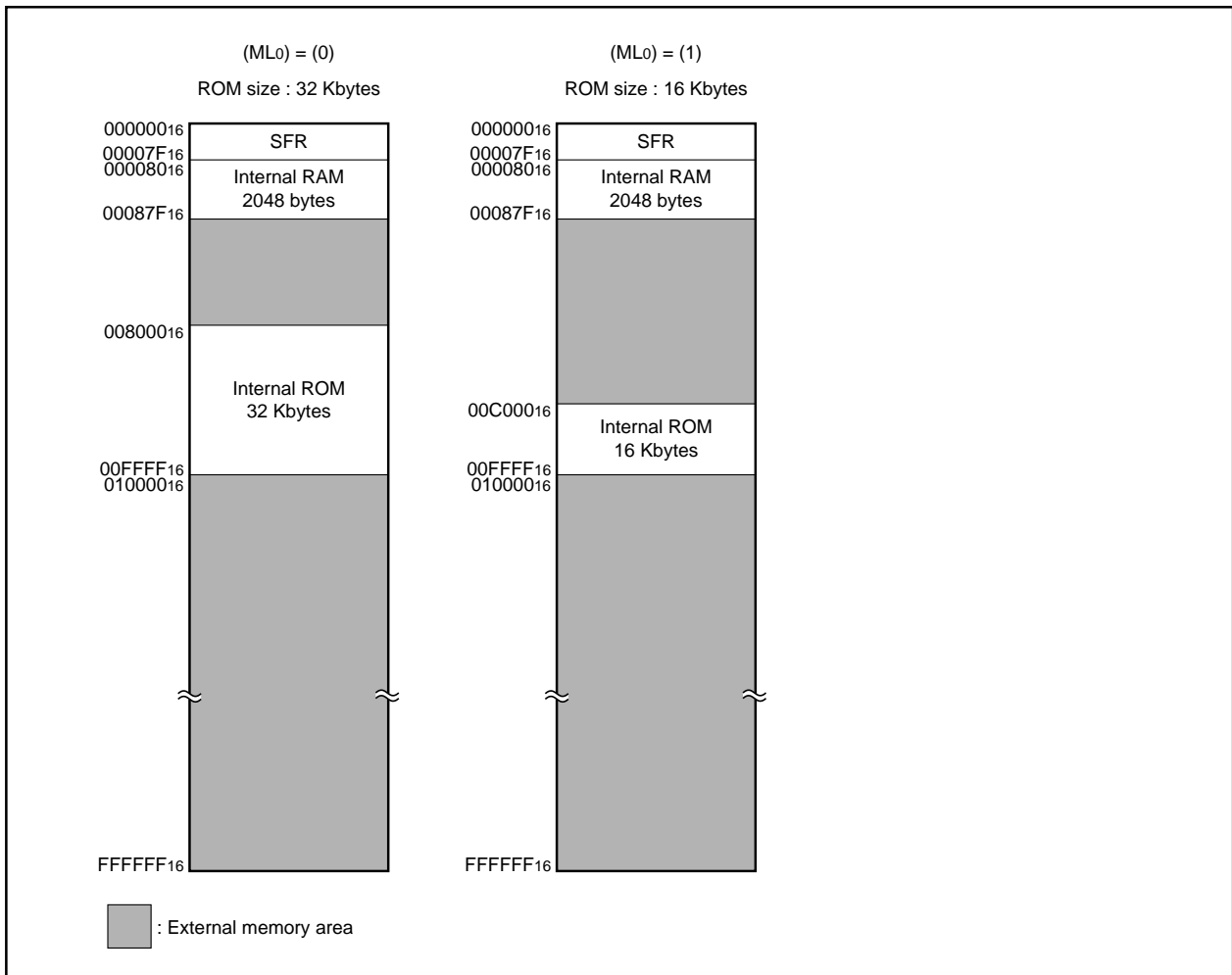

Fig. 6 Memory allocation (modification of internal ROM area by memory allocation selection bit)

ADDRESSING MODES

The M37733M4LXXXHP has 28 powerful addressing modes. Refer to the SINGLE-CHIP 16-BIT MICROCOMPUTERS DATA BOOK for the details of each addressing mode.

MACHINE INSTRUCTION LIST

The M37733M4LXXXHP has 103 machine instructions. Refer to the SINGLE-CHIP 16-BIT MICROCOMPUTERS DATA BOOK for details.

DATA REQUIRED FOR MASK ROM ORDERING

Please send the following data for mask orders.

- (1) M37733M4LXXXHP mask ROM order confirmation form
- (2) 80P6D mark specification form
- (3) ROM data (EPROM 3 sets)

PRELIMINARY
 Notice: This is not a final specification.
 Some parametric limits are subject to change.

ABSOLUTE MAXIMUM RATINGS

Symbol	Parameter	Conditions	Ratings	Unit
V _{cc}	Power source voltage		-0.3 to +7	V
AV _{cc}	Analog power source voltage		-0.3 to +7	V
V _i	Input voltage RESET, CNV _{ss} , BYTE		-0.3 to +12	V
V _i	Input voltage P00 – P07, P10 – P17, P20 – P27, P30 – P33, P40 – P47, P50 – P57, P60 – P67, P70 – P77, P80 – P87, V _{REF} , X _{IN}		-0.3 to V _{cc} + 0.3	V
V _o	Output voltage P00 – P07, P10 – P17, P20 – P27, P30 – P33, P40 – P47, P50 – P57, P60 – P67, P70 – P77, P80 – P87, X _{OUT} , E		-0.3 to V _{cc} + 0.3	V
P _d	Power dissipation	T _a = 25 °C	200	mW
T _{opr}	Operating temperature		-40 to +85	°C
T _{stg}	Storage temperature		-65 to +150	°C

RECOMMENDED OPERATING CONDITIONS (V_{cc} = 2.7 – 5.5 V, T_a = -40 to +85 °C, unless otherwise noted)

Symbol	Parameter	Limits			Unit
		Min.	Typ.	Max.	
V _{cc}	Power source voltage	f(X _{IN}) : Operating	2.7	5.5	V
		f(X _{IN}) : Stopped, f(X _{CIN}) = 32.768 kHz	2.7	5.5	
AV _{cc}	Analog power source voltage		V _{cc}	V	
V _{ss}	Power source voltage		0	V	
AV _{ss}	Analog power source voltage		0	V	
V _{IH}	High-level input voltage P00 – P07, P30 – P33, P40 – P47, P50 – P57, P60 – P67, P70 – P77, P80 – P87, X _{IN} , RESET, CNV _{ss} , BYTE, X _{CIN} (Note 3)	0.8 V _{cc}		V _{cc}	V
V _{IH}	High-level input voltage P10 – P17, P20 – P27 (in single-chip mode)	0.8 V _{cc}		V _{cc}	V
V _{IH}	High-level input voltage P10 – P17, P20 – P27 (in memory expansion mode and microprocessor mode)	0.5 V _{cc}		V _{cc}	V
V _{IL}	Low-level input voltage P00 – P07, P30 – P33, P40 – P47, P50 – P57, P60 – P67, P70 – P77, P80 – P87, X _{IN} , RESET, CNV _{ss} , BYTE, X _{CIN} (Note 3)	0		0.2V _{cc}	V
V _{IL}	Low-level input voltage P10 – P17, P20 – P27 (in single-chip mode)	0		0.2V _{cc}	V
V _{IL}	Low-level input voltage P10 – P17, P20 – P27 (in memory expansion mode and microprocessor mode)	0		0.16V _{cc}	V
I _{OH(peak)}	High-level peak output current P00 – P07, P10 – P17, P20 – P27, P30 – P33, P40 – P47, P50 – P57, P60 – P67, P70 – P77, P80 – P87			-10	mA
I _{OH(avg)}	High-level average output current P00 – P07, P10 – P17, P20 – P27, P30 – P33, P40 – P47, P50 – P57, P60 – P67, P70 – P77, P80 – P87			-5	mA
I _{OL(peak)}	Low-level peak output current P00 – P07, P10 – P17, P20 – P27, P30 – P33, P40 – P43, P54 – P57, P60 – P67, P70 – P77, P80 – P87			10	mA
I _{OL(peak)}	Low-level peak output current P44 – P47, P50 – P53			16	mA
I _{OL(avg)}	Low-level average output current P00 – P07, P10 – P17, P20 – P27, P30 – P33, P40 – P43, P54 – P57, P60 – P67, P70 – P77, P80 – P87			5	mA
I _{OL(avg)}	Low-level average output current P44 – P47, P50 – P53			12	mA
f(X _{IN})	Main-clock oscillation frequency (Note 4)			12	MHz
f(X _{CIN})	Sub-clock oscillation frequency		32.768	50	kHz

- Notes**
1. Average output current is the average value of a 100 ms interval.
 2. The sum of I_{OL(peak)} for ports P0, P1, P2, P3, and P8 must be 80 mA or less, the sum of I_{OH(peak)} for ports P0, P1, P2, P3, and P8 must be 80 mA or less, the sum of I_{OL(peak)} for ports P4, P5, P6, and P7 must be 100 mA or less, and the sum of I_{OH(peak)} for ports P4, P5, P6, and P7 must be 80 mA or less.
 3. Limits V_{IH} and V_{IL} for X_{CIN} are applied when the sub clock external input selection bit = "1".
 4. The maximum value of f(X_{IN}) = 6 MHz when the main clock division selection bit = "1".

PRELIMINARY
 Notice: This is not a final specification.
 Some parametric limits are subject to change.

MITSUBISHI MICROCOMPUTERS
M37733M4LXXXHP

SINGLE-CHIP 16-BIT CMOS MICROCOMPUTER

ELECTRICAL CHARACTERISTICS ($V_{CC} = 5\text{ V}$, $V_{SS} = 0\text{ V}$, $T_a = -40$ to $+85\text{ }^\circ\text{C}$, $f(X_{IN}) = 12\text{ MHz}$, unless otherwise noted)

Symbol	Parameter	Test conditions	Limits			Unit	
			Min.	Typ.	Max.		
V _{OH}	High-level output voltage P00 – P07, P10 – P17, P20 – P27, P33, P40 – P47, P50 – P57, P60 – P67, P70 – P77, P80 – P87	V _{CC} = 5 V, I _{OH} = –10 mA	3			V	
		V _{CC} = 3 V, I _{OH} = –1 mA	2.5				
V _{OH}	High-level output voltage P00 – P07, P10 – P17, P20 – P27, P33	V _{CC} = 5 V, I _{OH} = –400 μA	4.7			V	
V _{OH}	High-level output voltage P30 – P32	V _{CC} = 5 V, I _{OH} = –10 mA	3.1			V	
		V _{CC} = 5 V, I _{OH} = –400 μA	4.8				
		V _{CC} = 3 V, I _{OH} = –1 mA	2.6				
V _{OH}	High-level output voltage \bar{E}	V _{CC} = 5 V, I _{OH} = –10 mA	3.4			V	
		V _{CC} = 5 V, I _{OH} = –400 μA	4.8				
		V _{CC} = 3 V, I _{OH} = –1 mA	2.6				
V _{OL}	Low-level output voltage P00 – P07, P10 – P17, P20 – P27, P33, P40 – P43, P54 – P57, P60 – P67, P70 – P77, P80 – P87	V _{CC} = 5 V, I _{OL} = 10 mA			2	V	
		V _{CC} = 3 V, I _{OL} = 1 mA			0.5		
V _{OL}	Low-level output voltage P44 – P47, P50 – P53	V _{CC} = 5 V, I _{OL} = 16 mA			1.8	V	
		V _{CC} = 3 V, I _{OL} = 10 mA			1.5		
V _{OL}	Low-level output voltage P00 – P07, P10 – P17, P20 – P27, P33	V _{CC} = 5 V, I _{OL} = 2 mA			0.45	V	
V _{OL}	Low-level output voltage P30 – P32	V _{CC} = 5 V, I _{OL} = 10 mA			1.9	V	
		V _{CC} = 5 V, I _{OL} = 2 mA			0.43		
		V _{CC} = 3 V, I _{OL} = 1 mA			0.4		
V _{OL}	Low-level output voltage \bar{E}	V _{CC} = 5 V, I _{OL} = 10 mA			1.6	V	
		V _{CC} = 5 V, I _{OL} = 2 mA			0.4		
		V _{CC} = 3 V, I _{OL} = 1 mA			0.4		
V _{T+} – V _{T–}	Hysteresis HOLD, RDY, TA0IN – TA4IN, TB0IN – TB2IN, INT0 – INT2, ADTRG, CTS0, CTS1, CTS2, CLK0, CLK1, CLK2, KI0 – KI3	V _{CC} = 5 V	0.4		1	V	
		V _{CC} = 3 V	0.1		0.7		
V _{T+} – V _{T–}	Hysteresis RESET	V _{CC} = 5 V	0.2		0.5	V	
		V _{CC} = 3 V	0.1		0.4		
V _{T+} – V _{T–}	Hysteresis X _{IN}	V _{CC} = 5 V	0.1		0.4	V	
		V _{CC} = 3 V	0.06		0.26		
V _{T+} – V _{T–}	Hysteresis X _{CIN} (When external clock is input)	V _{CC} = 5 V	0.1		0.4	V	
		V _{CC} = 3 V	0.06		0.26		
I _{IH}	High-level input current P00 – P07, P10 – P17, P20 – P27, P30 – P33, P40 – P47, P50 – P57, P60 – P67, P70 – P77, P80 – P87, X _{IN} , RESET, CNVss, BYTE	V _{CC} = 5 V, V _I = 5 V			5	μA	
		V _{CC} = 3 V, V _I = 3 V			4		
I _{IL}	Low-level input current P00 – P07, P10 – P17, P20 – P27, P30 – P33, P40 – P47, P50 – P53, P60, P61, P65 – P67, P70 – P77, P80 – P87, X _{IN} , RESET, CNVss, BYTE	V _{CC} = 5 V, V _I = 0 V			–5	μA	
		V _{CC} = 3 V, V _I = 0 V			–4		
I _{IL}	Low-level input current P54 – P57, P62 – P64	V _I = 0 V, without a pull-up transistor	V _{CC} = 5 V			–5	μA
			V _{CC} = 3 V			–4	
		V _I = 0 V, with a pull-up transistor	V _{CC} = 5 V	–0.25	–0.5	–1.0	mA
			V _{CC} = 3 V	–0.08	–0.18	–0.35	
V _{RAM}	RAM hold voltage	When clock is stopped.	2			V	

ELECTRICAL CHARACTERISTICS ($V_{CC} = 5\text{ V}$, $V_{SS} = 0\text{ V}$, $T_a = -40$ to $+85\text{ }^\circ\text{C}$, unless otherwise noted)

Symbol	Parameter	Test conditions	Limits			Unit		
			Min.	Typ.	Max.			
I _{CC}	Power source current	When single-chip mode, output pins are open, and other pins are V _{SS} .	V _{CC} = 5 V, f(X _{IN}) = 12 MHz (square waveform), (f(f ₂) = 6 MHz), f(X _{CIN}) = 32.768 kHz, in operating (Note 1)		4.5	9	mA	
			V _{CC} = 3 V, f(X _{IN}) = 12 MHz (square waveform), (f(f ₂) = 6 MHz), f(X _{CIN}) = 32.768 kHz, in operating (Note 1)		3	6	mA	
			V _{CC} = 3 V, f(X _{IN}) = 12 MHz (square waveform), (f(f ₂) = 0.75 MHz), f(X _{CIN}) : Stopped, in operating		0.4	0.8	mA	
			V _{CC} = 3 V, f(X _{IN}) = 12 MHz (square waveform), f(X _{CIN}) = 32.768 kHz, when a WIT instruction is executed (Note 2)		6	12	μA	
			V _{CC} = 3 V, f(X _{IN}) : Stopped, f(X _{CIN}) = 32.768 kHz, in operating (Note 3)		30	60	μA	
			V _{CC} = 3 V, f(X _{IN}) : Stopped, f(X _{CIN}) = 32.768 kHz, when a WIT instruction is executed (Note 4)		3	6	μA	
			T _a = 25 °C, when clock is stopped				1	μA
			T _a = 85 °C, when clock is stopped				20	μA

- Notes**
1. This applies when the main clock external input selection bit = "1", the main clock division selection bit = "0", and the signal output stop bit = "1".
 2. This applies when the main clock external input selection bit = "1" and the system clock stop bit at wait state = "1".
 3. This applies when CPU and the clock timer are operating with the sub clock (32.768 kHz) selected as the system clock.
 4. This applies when the X_{COUT} drivability selection bit = "0" and the system clock stop bit at wait state = "1".

A-D CONVERTER CHARACTERISTICS

($V_{CC} = AV_{CC} = 5\text{ V}$, $V_{SS} = AV_{SS} = 0\text{ V}$, $T_a = -40$ to $+85\text{ }^\circ\text{C}$, $f(X_{IN}) = 12\text{ MHz}$, unless otherwise noted (Note))

Symbol	Parameter	Test conditions	Limits			Unit
			Min.	Typ.	Max.	
—	Resolution	V _{REF} = V _{CC}			10	Bits
—	Absolute accuracy	V _{REF} = V _{CC}			± 3	LSB
RLADDER	Ladder resistance	V _{REF} = V _{CC}	10		25	kΩ
t _{CONV}	Conversion time		19.6			μs
V _{REF}	Reference voltage		2.7		V _{CC}	V
V _{IA}	Analog input voltage		0		V _{REF}	V

Note. This applies when the main clock division selection bit = "0" and f(f₂) = 6 MHz.

PRELIMINARY
 Notice: This is not a final specification.
 Some parametric limits are subject to change.

MITSUBISHI MICROCOMPUTERS
M37733M4LXXXHP

SINGLE-CHIP 16-BIT CMOS MICROCOMPUTER

TIMING REQUIREMENTS ($V_{CC} = 2.7 - 5.5 \text{ V}$, $V_{SS} = 0 \text{ V}$, $T_a = -40 \text{ to } +85 \text{ }^\circ\text{C}$, $f(X_{IN}) = 12 \text{ MHz}$, unless otherwise noted (Note 1))

Notes 1. This applies when the main clock division selection bit = "0" and $f(f_2) = 6 \text{ MHz}$.

2. Input signal's rise/fall time must be 100 ns or less, unless otherwise noted.

External clock input

Symbol	Parameter	Limits		Unit
		Min.	Max.	
t_c	External clock input cycle time (Note 1)	83		ns
$t_{w(H)}$	External clock input high-level pulse width (Note 2)	33		ns
$t_{w(L)}$	External clock input low-level pulse width (Note 2)	33		ns
t_r	External clock rise time		15	ns
t_f	External clock fall time		15	ns

Notes 1. When the main clock division selection bit = "1", the minimum value of $t_c = 166 \text{ ns}$.

2. When the main clock division selection bit = "1", values of $t_{w(H)} / t_c$ and $t_{w(L)} / t_c$ must be set to values from 0.45 through 0.55.

Single-chip mode

Symbol	Parameter	Limits		Unit
		Min.	Max.	
$t_{su}(P0D-E)$	Port P0 input setup time	200		ns
$t_{su}(P1D-E)$	Port P1 input setup time	200		ns
$t_{su}(P2D-E)$	Port P2 input setup time	200		ns
$t_{su}(P3D-E)$	Port P3 input setup time	200		ns
$t_{su}(P4D-E)$	Port P4 input setup time	200		ns
$t_{su}(P5D-E)$	Port P5 input setup time	200		ns
$t_{su}(P6D-E)$	Port P6 input setup time	200		ns
$t_{su}(P7D-E)$	Port P7 input setup time	200		ns
$t_{su}(P8D-E)$	Port P8 input setup time	200		ns
$t_{h(E-P0D)}$	Port P0 input hold time	0		ns
$t_{h(E-P1D)}$	Port P1 input hold time	0		ns
$t_{h(E-P2D)}$	Port P2 input hold time	0		ns
$t_{h(E-P3D)}$	Port P3 input hold time	0		ns
$t_{h(E-P4D)}$	Port P4 input hold time	0		ns
$t_{h(E-P5D)}$	Port P5 input hold time	0		ns
$t_{h(E-P6D)}$	Port P6 input hold time	0		ns
$t_{h(E-P7D)}$	Port P7 input hold time	0		ns
$t_{h(E-P8D)}$	Port P8 input hold time	0		ns

Memory expansion mode and microprocessor mode

Symbol	Parameter	Limits		Unit
		Min.	Max.	
$t_{su}(D-E)$	Data input setup time	80		ns
$t_{su}(RDY-\phi_1)$	RDY input setup time	80		ns
$t_{su}(HOLD-\phi_1)$	HOLD input setup time	80		ns
$t_{h(E-D)}$	Data input hold time	0		ns
$t_{h}(\phi_1-RDY)$	RDY input hold time	0		ns
$t_{h}(\phi_1-HOLD)$	HOLD input hold time	0		ns

Timer A input (Count input in event counter mode)

Symbol	Parameter	Limits		Unit
		Min.	Max.	
t _c (TA)	TAiIn input cycle time	250		ns
t _w (TAH)	TAiIn input high-level pulse width	125		ns
t _w (TAL)	TAiIn input low-level pulse width	125		ns

Timer A input (Gating input in timer mode)

Symbol	Parameter	Limits		Unit
		Min.	Max.	
t _c (TA)	TAiIn input cycle time (Note)	666		ns
t _w (TAH)	TAiIn input high-level pulse width (Note)	333		ns
t _w (TAL)	TAiIn input low-level pulse width (Note)	333		ns

Note. Limits change depending on f(X_{IN}). Refer to "DATA FORMULAS".

Timer A input (External trigger input in one-shot pulse mode)

Symbol	Parameter	Limits		Unit
		Min.	Max.	
t _c (TA)	TAiIn input cycle time (Note)	666		ns
t _w (TAH)	TAiIn input high-level pulse width	166		ns
t _w (TAL)	TAiIn input low-level pulse width	166		ns

Note. Limits change depending on f(X_{IN}). Refer to "DATA FORMULAS".

Timer A input (External trigger input in pulse width modulation mode)

Symbol	Parameter	Limits		Unit
		Min.	Max.	
t _w (TAH)	TAiIn input high-level pulse width	166		ns
t _w (TAL)	TAiIn input low-level pulse width	166		ns

Timer A input (Up-down input in event counter mode)

Symbol	Parameter	Limits		Unit
		Min.	Max.	
t _c (UP)	TAiOUT input cycle time	3333		ns
t _w (UPH)	TAiOUT input high-level pulse width	1666		ns
t _w (UPL)	TAiOUT input low-level pulse width	1666		ns
t _{su} (UP-T _{IN})	TAiOUT input setup time	666		ns
t _h (T _{IN} -UP)	TAiOUT input hold time	666		ns

Timer A input (Two-phase pulse input in event counter mode)

Symbol	Parameter	Limits		Unit
		Min.	Max.	
t _c (TA)	TAjIN input cycle time	2000		ns
t _{su} (TAjIN-TAjOUT)	TAjIN input setup time	500		ns
t _{su} (TAjOUT-TAjIN)	TAjOUT input setup time	500		ns

PRELIMINARY
 Notice: This is not a final specification.
 Some parametric limits are subject to change.

Timer B input (Count input in event counter mode)

Symbol	Parameter	Limits		Unit
		Min.	Max.	
t _c (TB)	TBiN input cycle time (one edge count)	250		ns
t _w (TBH)	TBiN input high-level pulse width (one edge count)	125		ns
t _w (TBL)	TBiN input low-level pulse width (one edge count)	125		ns
t _c (TB)	TBiN input cycle time (both edges count)	500		ns
t _w (TBH)	TBiN input high-level pulse width (both edges count)	250		ns
t _w (TBL)	TBiN input low-level pulse width (both edges count)	250		ns

Timer B input (Pulse period measurement mode)

Symbol	Parameter	Limits		Unit
		Min.	Max.	
t _c (TB)	TBiN input cycle time (Note)	666		ns
t _w (TBH)	TBiN input high-level pulse width (Note)	333		ns
t _w (TBL)	TBiN input low-level pulse width (Note)	333		ns

Note. Limits change depending on f(X_{IN}). Refer to "DATA FORMULAS".

Timer B input (Pulse width measurement mode)

Symbol	Parameter	Limits		Unit
		Min.	Max.	
t _c (TB)	TBiN input cycle time (Note)	666		ns
t _w (TBH)	TBiN input high-level pulse width (Note)	333		ns
t _w (TBL)	TBiN input low-level pulse width (Note)	333		ns

Note. Limits change depending on f(X_{IN}). Refer to "DATA FORMULAS".

A-D trigger input

Symbol	Parameter	Limits		Unit
		Min.	Max.	
t _c (AD)	AD _{TRG} input cycle time (minimum allowable trigger)	1333		ns
t _w (ADL)	AD _{TRG} input low-level pulse width	166		ns

Serial I/O

Symbol	Parameter	Limits		Unit
		Min.	Max.	
t _c (CK)	CLK _i input cycle time	333		ns
t _w (CKH)	CLK _i input high-level pulse width	166		ns
t _w (CKL)	CLK _i input low-level pulse width	166		ns
t _d (C-Q)	TxD _i output delay time		100	ns
t _h (C-Q)	TxD _i hold time	0		ns
t _{su} (D-C)	RxD _i input setup time	65		ns
t _h (C-D)	RxD _i input hold time	75		ns

External interrupt INT_i input, key input interrupt KI_i input

Symbol	Parameter	Limits		Unit
		Min.	Max.	
t _w (INH)	INT _i input high-level pulse width	250		ns
t _w (INL)	INT _i input low-level pulse width	250		ns
t _w (KIL)	KI _i input low-level pulse width	250		ns

DATA FORMULAS

Timer A input (Gating input in timer mode)

Symbol	Parameter	Limits		Unit
		Min.	Max.	
$t_{c(TA)}$	TAiIn input cycle time	$\frac{8 \times 10^9}{2 \cdot f(f_2)}$		ns
$t_{w(TAH)}$	TAiIn input high-level pulse width	$\frac{4 \times 10^9}{2 \cdot f(f_2)}$		ns
$t_{w(TAL)}$	TAiIn input low-level pulse width	$\frac{4 \times 10^9}{2 \cdot f(f_2)}$		ns

Timer A input (External trigger input in one-shot pulse mode)

Symbol	Parameter	Limits		Unit
		Min.	Max.	
$t_{c(TA)}$	TAiIn input cycle time	$\frac{8 \times 10^9}{2 \cdot f(f_2)}$		ns

Timer B input (In pulse period measurement mode or pulse width measurement mode)

Symbol	Parameter	Limits		Unit
		Min.	Max.	
$t_{c(TB)}$	TBiIn input cycle time	$\frac{8 \times 10^9}{2 \cdot f(f_2)}$		ns
$t_{w(TBH)}$	TBiIn input high-level pulse width	$\frac{4 \times 10^9}{2 \cdot f(f_2)}$		ns
$t_{w(TBL)}$	TBiIn input low-level pulse width	$\frac{4 \times 10^9}{2 \cdot f(f_2)}$		ns

Note. $f(f_2)$ represents the clock f_2 frequency.

For the relation to the main clock and sub clock, refer to Table 9 in data sheet "M37733MHBXXXFP".

PRELIMINARY
 Notice: This is not a final specification.
 Some parametric limits are subject to change.

SWITCHING CHARACTERISTICS

($V_{CC} = 2.7 - 5.5$ V, $V_{SS} = 0$ V, $T_a = -40$ to $+85^\circ\text{C}$, $f(X_{IN}) = 12$ MHz, unless otherwise noted (Note))

Single-chip mode

Symbol	Parameter	Test conditions	Limits		Unit
			Min.	Max.	
$t_{d(E-P0Q)}$	Port P0 data output delay time	Fig. 7		300	ns
$t_{d(E-P1Q)}$	Port P1 data output delay time			300	ns
$t_{d(E-P2Q)}$	Port P2 data output delay time			300	ns
$t_{d(E-P3Q)}$	Port P3 data output delay time			300	ns
$t_{d(E-P4Q)}$	Port P4 data output delay time			300	ns
$t_{d(E-P5Q)}$	Port P5 data output delay time			300	ns
$t_{d(E-P6Q)}$	Port P6 data output delay time			300	ns
$t_{d(E-P7Q)}$	Port P7 data output delay time			300	ns
$t_{d(E-P8Q)}$	Port P8 data output delay time			300	ns

Note. This applies when the main clock division selection bit = "0" and $f(f_2) = 6$ MHz.

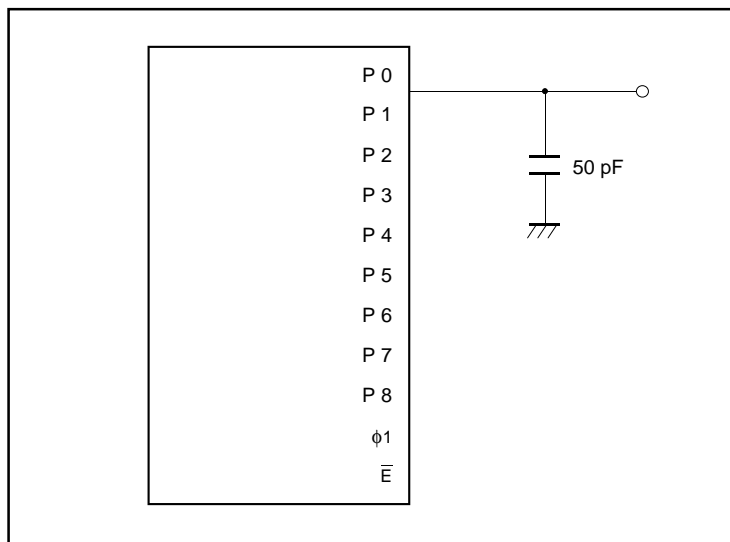

Fig. 7 Measuring circuit for ports P0 – P8 and ϕ_1

PRELIMINARY
 Notice: This is not a final specification.
 Some parametric limits are subject to change.

Memory expansion mode and microprocessor mode

(VCC = 2.7 – 5.5 V, VSS = 0 V, Ta = –40 to +85°C, f(XIN) = 12 MHz (Note 1), unless otherwise noted)

Symbol	Parameter	(Note 2) Wait mode	Test conditions	Limits		Unit
				Min.	Max.	
td(An–E)	Address output delay time	No wait	Fig. 7	20		ns
		Wait 1				
		Wait 0		182		ns
td(A–E)	Address output delay time	No wait		20		ns
		Wait 1				
		Wait 0		162		ns
th(E–An)	Address hold time			40		ns
tw(ALE)	ALE pulse width	No wait		40		ns
		Wait 1				
		Wait 0		123		ns
tsu(A–ALE)	Address output set up time	No wait		10		ns
		Wait 1				
		Wait 0		93		ns
th(ALE–A)	Address hold time	No wait		9		ns
		Wait 1				
		Wait 0		40		ns
td(ALE–E)	ALE output delay time	No wait		4		ns
		Wait 1				
		Wait 0	40		ns	
fd(E–DQ)	Data output delay time			90	ns	
th(E–DQ)	Data hold time		40		ns	
tw(EL)	E pulse width	No wait	131		ns	
		Wait 1				
		Wait 0	298		ns	
tpxz(E–DZ)	Floating start delay time			10	ns	
fpzx(E–DZ)	Floating release delay time		53		ns	
td(BHE–E)	BHE output delay time	No wait	20		ns	
		Wait 1				
		Wait 0	182		ns	
td(R/W–E)	R/W output delay time	No wait	20		ns	
		Wait 1				
		Wait 0	182		ns	
th(E–BHE)	BHE hold time		33		ns	
th(E–R/W)	R/W hold time		33		ns	
td(E–φ1)	φ1 output delay time		0	30	ns	
td(φ1–HLDA)	HLDA output delay time			120	ns	

Notes 1. This applies when the main clock division selection bit = "0" and f(f2) = 6 MHz.

2. No wait : Wait bit = "1".

Wait 1 : The external memory area is accessed with wait bit = "0" and wait selection bit = "1".

Wait 0 : The external memory area is accessed with wait bit = "0" and wait selection bit = "0".

PRELIMINARY
 Notice: This is not a final specification.
 Some parametric limits are subject to change.

MITSUBISHI MICROCOMPUTERS
M37733M4LXXXHP

SINGLE-CHIP 16-BIT CMOS MICROCOMPUTER

Bus timing data formulas ($V_{CC} = 2.7 - 5.5 \text{ V}$, $V_{SS} = 0 \text{ V}$, $T_a = -40 \text{ to } +85 \text{ }^\circ\text{C}$, $f(X_{IN}) = 12 \text{ MHz}$ (Max., Note 1), unless otherwise noted)

Symbol	Parameter	Wait mode	Limits		Unit
			Min.	Max.	
td(An-E)	Address output delay time	No wait	$\frac{1 \times 10^9}{2 \cdot f(f_2)} - 63$		ns
		Wait 1	$\frac{3 \times 10^9}{2 \cdot f(f_2)} - 68$		ns
td(A-E)	Address output delay time	No wait	$\frac{1 \times 10^9}{2 \cdot f(f_2)} - 63$		ns
		Wait 1	$\frac{3 \times 10^9}{2 \cdot f(f_2)} - 88$		ns
th(E-An)	Address hold time		$\frac{1 \times 10^9}{2 \cdot f(f_2)} - 43$		ns
tw(ALE)	ALE pulse width	No wait	$\frac{1 \times 10^9}{2 \cdot f(f_2)} - 43$		ns
		Wait 1	$\frac{2 \times 10^9}{2 \cdot f(f_2)} - 43$		ns
tsu(A-ALE)	Address output set up time	No wait	$\frac{1 \times 10^9}{2 \cdot f(f_2)} - 73$		ns
		Wait 1	$\frac{2 \times 10^9}{2 \cdot f(f_2)} - 73$		ns
th(ALE-A)	Address hold time	No wait	9		ns
		Wait 1	$\frac{1 \times 10^9}{2 \cdot f(f_2)} - 43$		ns
td(ALE-E)	ALE output delay time	No wait	4		ns
		Wait 1	$\frac{1 \times 10^9}{2 \cdot f(f_2)} - 43$		ns
td(E-DQ)	Data output delay time			90	ns
th(E-DQ)	Data hold time		$\frac{1 \times 10^9}{2 \cdot f(f_2)} - 43$		ns
tw(EL)	\bar{E} pulse width	No wait	$\frac{2 \times 10^9}{2 \cdot f(f_2)} - 35$		ns
		Wait 1	$\frac{4 \times 10^9}{2 \cdot f(f_2)} - 35$		ns
tpxz(E-DZ)	Floating start delay time			10	ns
tpzx(E-DZ)	Floating release delay time		$\frac{1 \times 10^9}{2 \cdot f(f_2)} - 30$		ns
td(BHE-E)	\overline{BHE} output delay time	No wait	$\frac{1 \times 10^9}{2 \cdot f(f_2)} - 63$		ns
		Wait 1	$\frac{3 \times 10^9}{2 \cdot f(f_2)} - 68$		ns
td(R/W-E)	R/\overline{W} output delay time	No wait	$\frac{1 \times 10^9}{2 \cdot f(f_2)} - 63$		ns
		Wait 1	$\frac{3 \times 10^9}{2 \cdot f(f_2)} - 68$		ns
th(E-BHE)	\overline{BHE} hold time		$\frac{1 \times 10^9}{2 \cdot f(f_2)} - 50$		ns
th(E-R/W)	R/\overline{W} hold time		$\frac{1 \times 10^9}{2 \cdot f(f_2)} - 50$		ns
td(E-φ1)	φ1 output delay time		0	30	ns

Notes 1. This applies when the main-clock division selection bit = "0".

2. $f(f_2)$ represents the clock f_2 frequency.

For the relation to the main clock and sub clock, refer to Table 9 in data sheet "M37733MHBXXXFP".

PRELIMINARY
 Notice: This is not a final specification.
 Some parametric limits are subject to change.

TIMING DIAGRAM

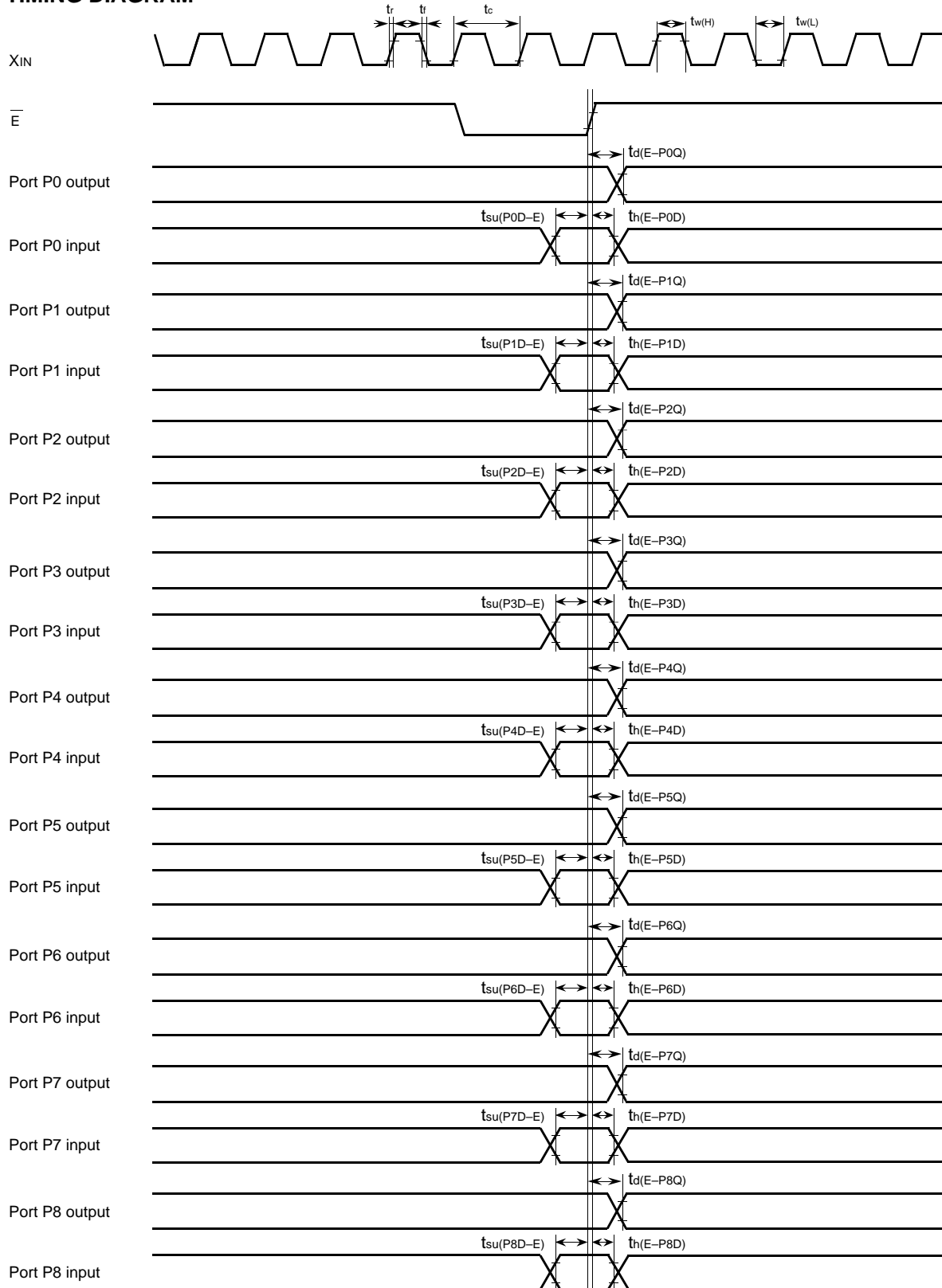

PRELIMINARY
 Notice: This is not a final specification.
 Some parametric limits are subject to change.

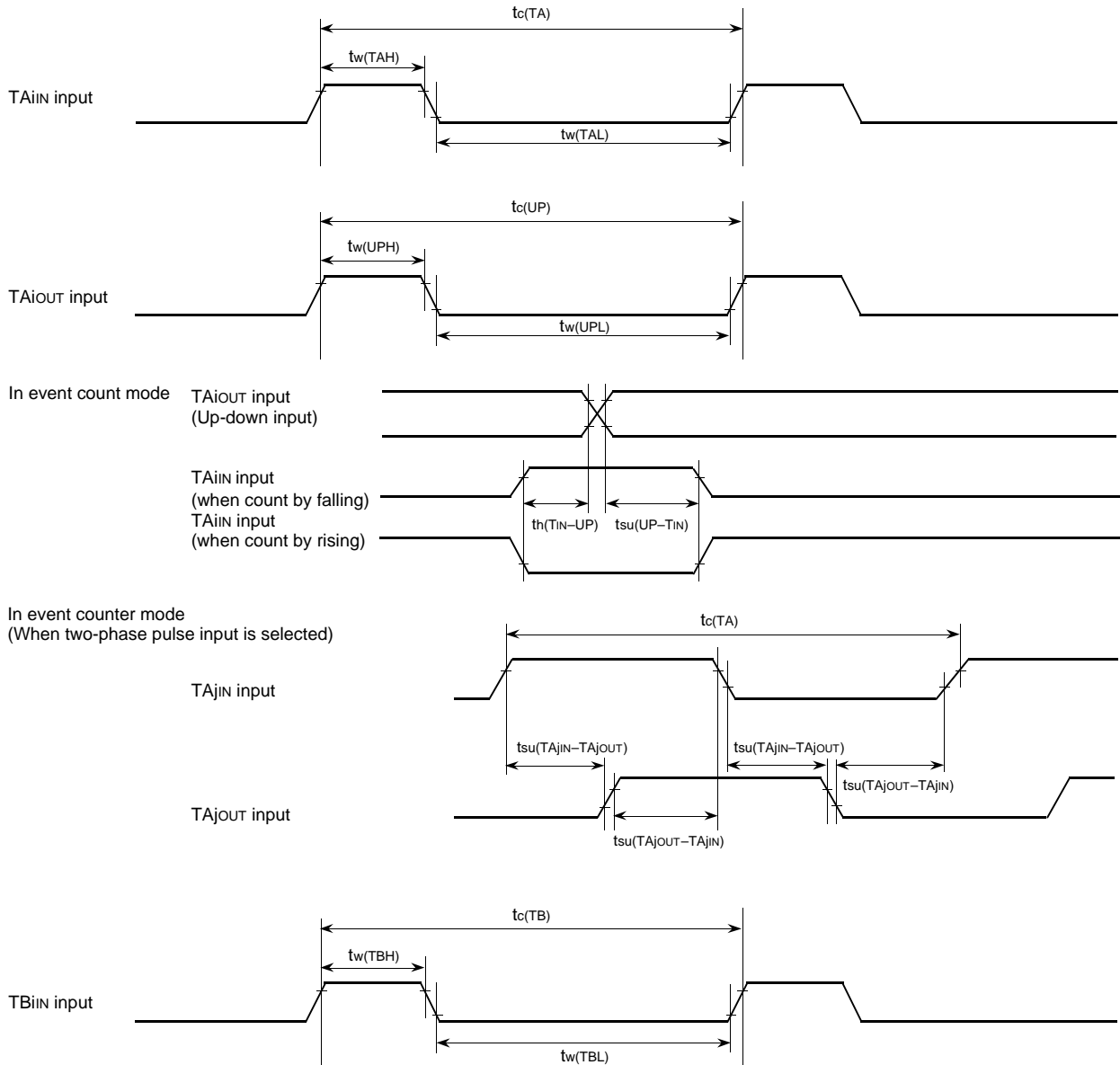

PRELIMINARY
 Notice: This is not a final specification.
 Some parametric limits are subject to change.

MITSUBISHI MICROCOMPUTERS
M37733M4LXXXHP

SINGLE-CHIP 16-BIT CMOS MICROCOMPUTER

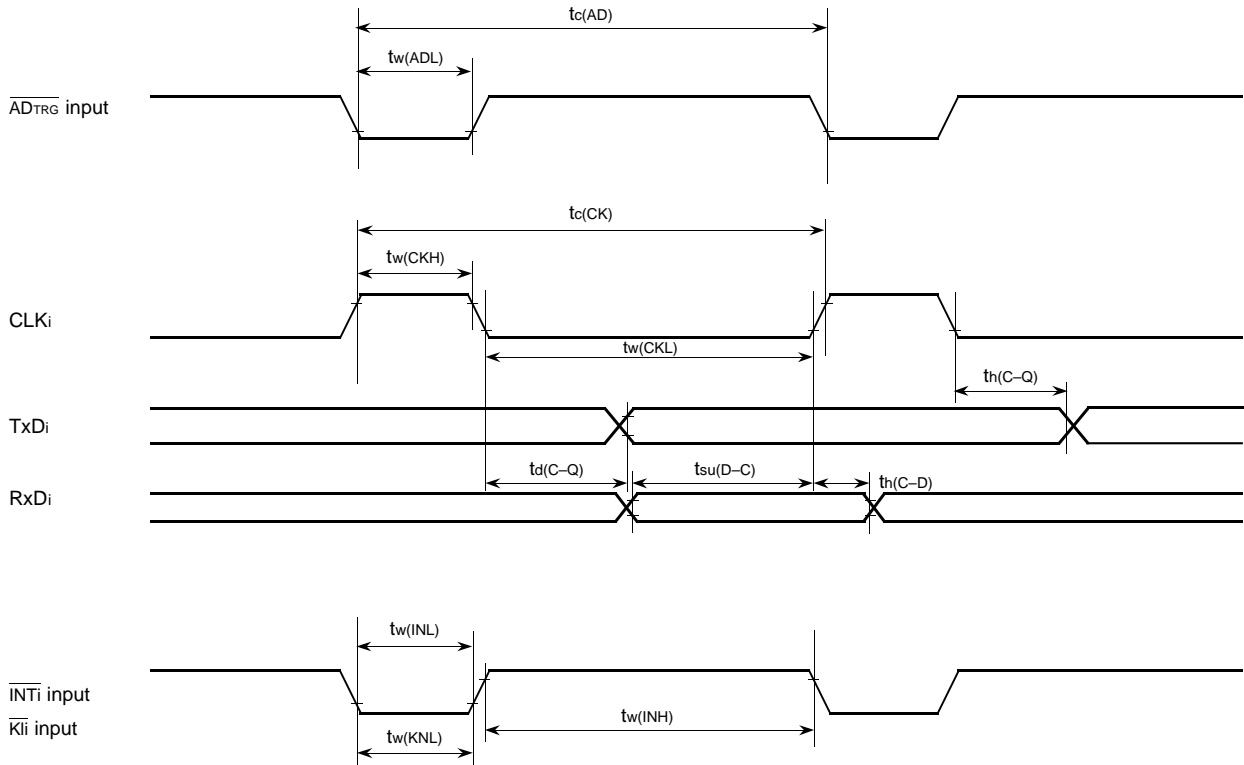

PRELIMINARY
 Notice: This is not a final specification.
 Some parametric limits are subject to change.

Memory expansion mode and microprocessor mode
 (When wait bit = "1")

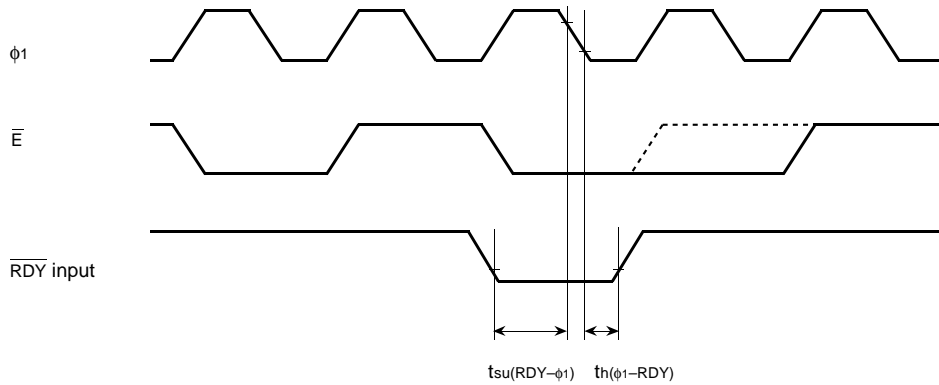

(When wait bit = "0")

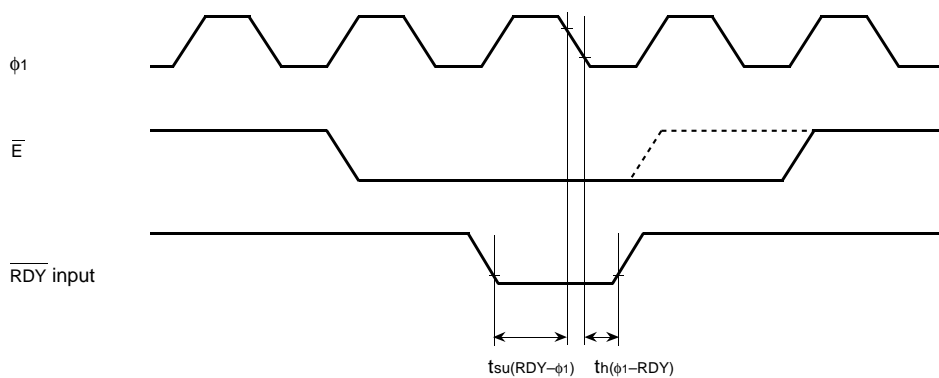

(When wait bit = "1" or "0" in common)

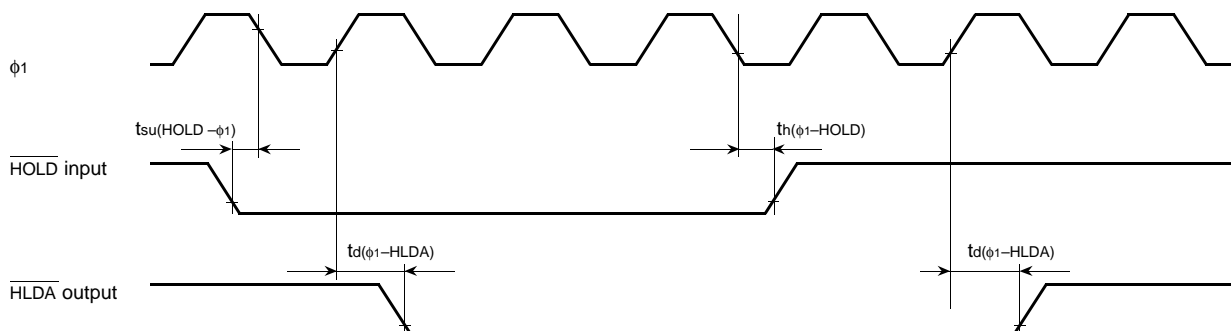

Test conditions

- $V_{CC} = 2.7 - 5.5 \text{ V}$
- Input timing voltage : $V_{IL} = 0.2 V_{CC}$, $V_{IH} = 0.8 V_{CC}$
- Output timing voltage : $V_{OL} = 0.8 \text{ V}$, $V_{OH} = 2.0 \text{ V}$

PRELIMINARY
 Notice: This is not a final specification.
 Some parametric limits are subject to change.

MITSUBISHI MICROCOMPUTERS
M37733M4LXXXHP

SINGLE-CHIP 16-BIT CMOS MICROCOMPUTER

Memory expansion mode and microprocessor mode
 (No wait : When wait bit = "1")

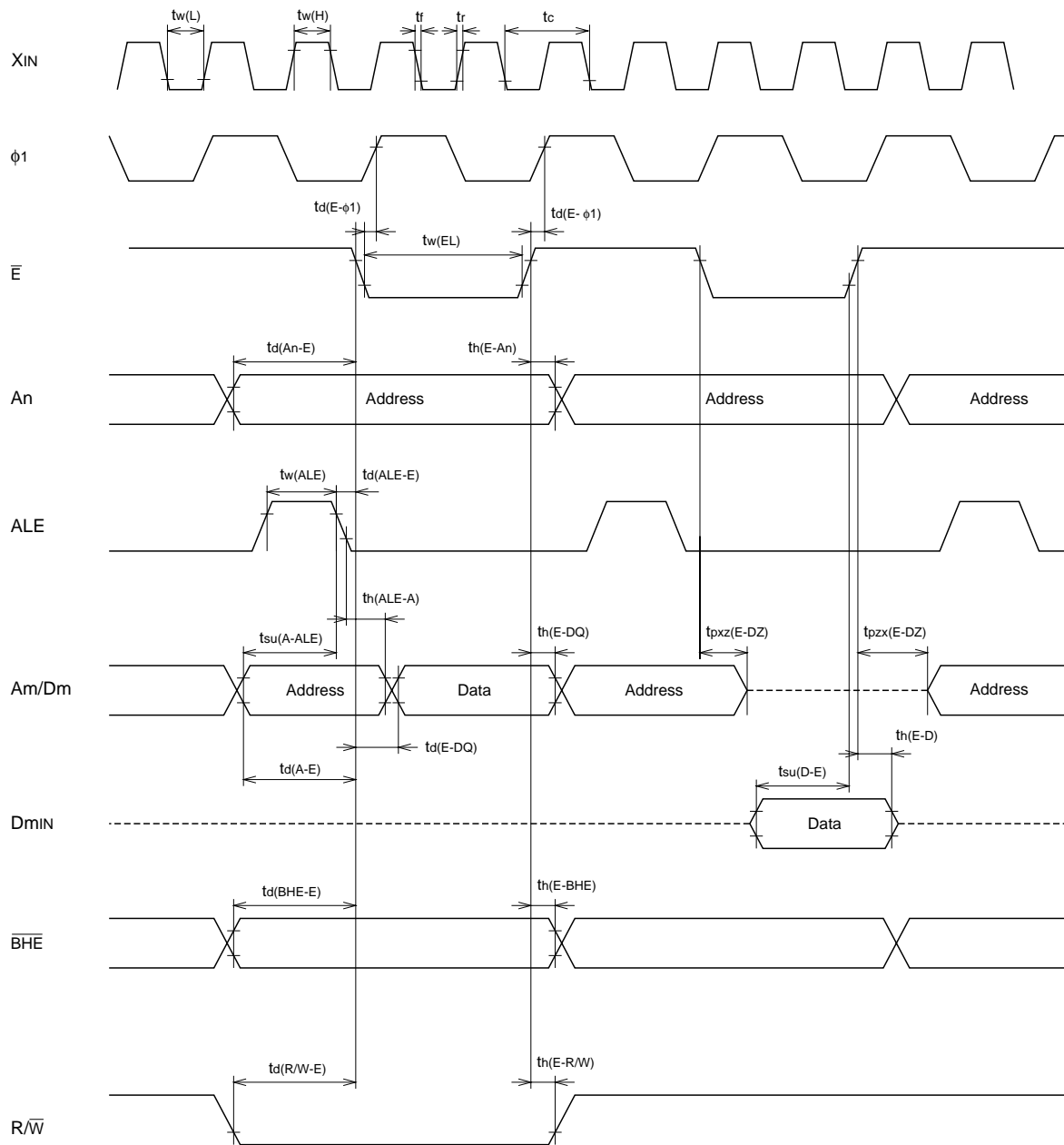

Test conditions

- $V_{CC} = 2.7 - 5.5$ V
- Output timing voltage : $V_{OL} = 0.8$ V, $V_{OH} = 2.0$ V
- Data input D_{min} : $V_{IL} = 0.16 V_{CC}$, $V_{IH} = 0.5 V_{CC}$

PRELIMINARY
 Notice: This is not a final specification.
 Some parametric limits are subject to change.

Memory expansion mode and microprocessor mode
 (Wait 1 : The external area is accessed when wait bit = "0" and wait selection bit = "1".)

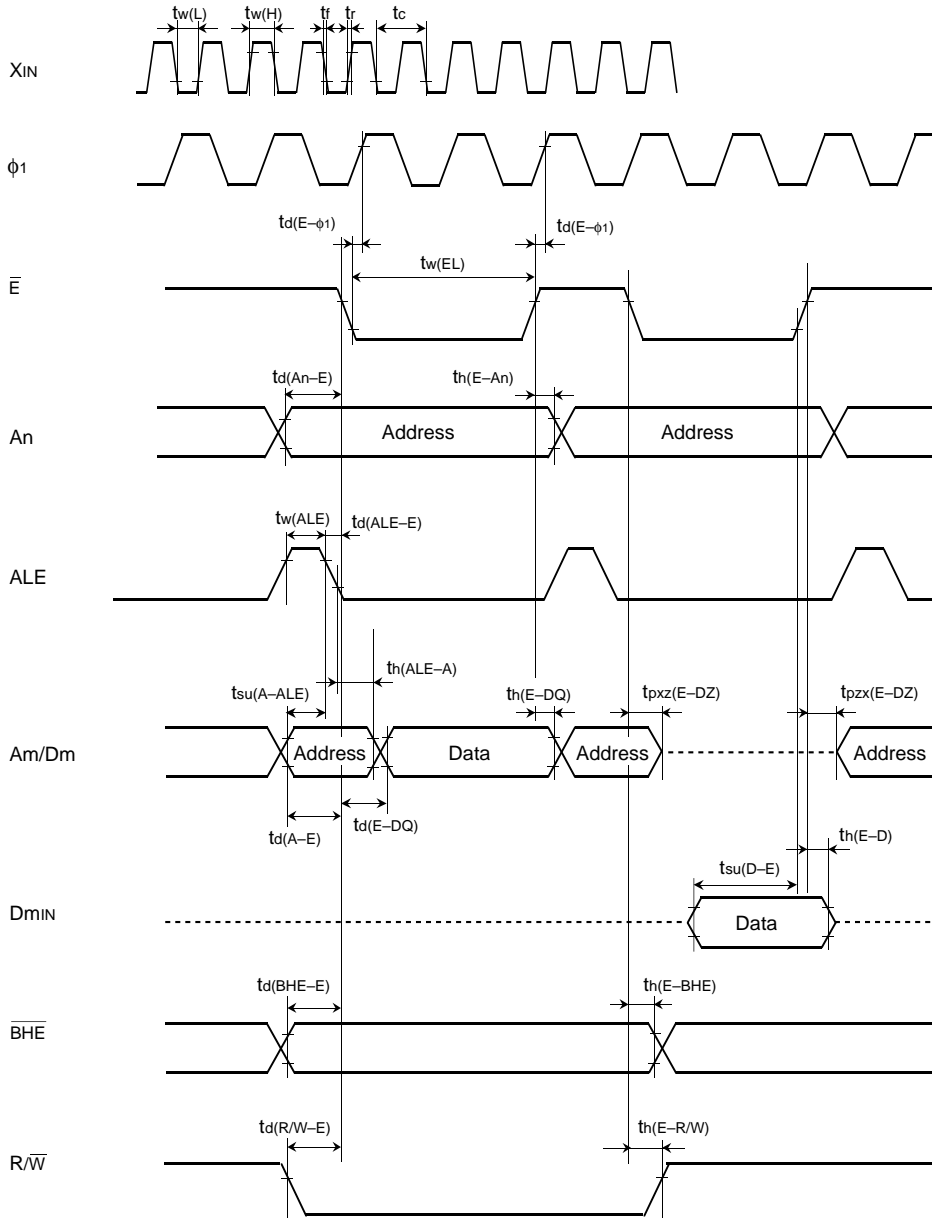

Test conditions

- $V_{CC} = 2.7 - 5.5 V$
- Output timing voltage : $V_{OL} = 0.8 V, V_{OH} = 2.0 V$
- Data input D_{min} : $V_{IL} = 0.16 V_{CC}, V_{IH} = 0.5 V_{CC}$

PRELIMINARY
 Notice: This is not a final specification.
 Some parametric limits are subject to change.

MITSUBISHI MICROCOMPUTERS
M37733M4LXXXHP

SINGLE-CHIP 16-BIT CMOS MICROCOMPUTER

Memory expansion mode and microprocessor mode
 (Wait 0 : The external memory area is accessed when wait bit = "0" and wait selection bit = "0".)

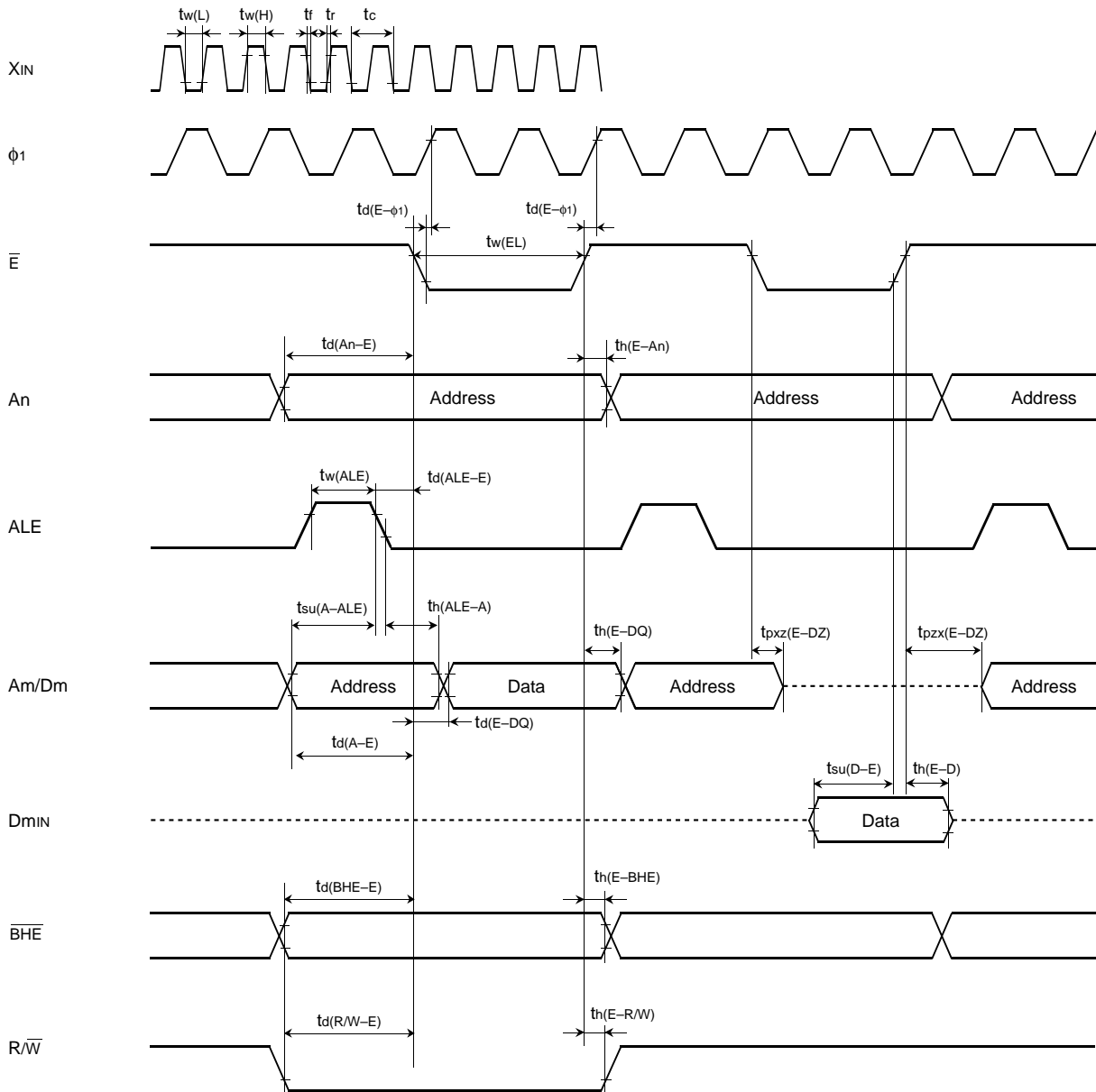

- Test conditions
- $V_{CC} = 2.7 - 5.5 \text{ V}$
 - Output timing voltage : $V_{OL} = 0.8 \text{ V}$, $V_{OH} = 2.0 \text{ V}$
 - Data input D_{min} : $V_{IL} = 0.16 V_{CC}$, $V_{IH} = 0.5 V_{CC}$

PRELIMINARY
 Notice: This is not a final specification.
 Some parametric limits are subject to change.

MITSUBISHI MICROCOMPUTERS
M37733M4LXXXHP

SINGLE-CHIP 16-BIT CMOS MICROCOMPUTER

PACKAGE OUTLINE

80P6D-A

Plastic 80pin 12x12mm body LQFP

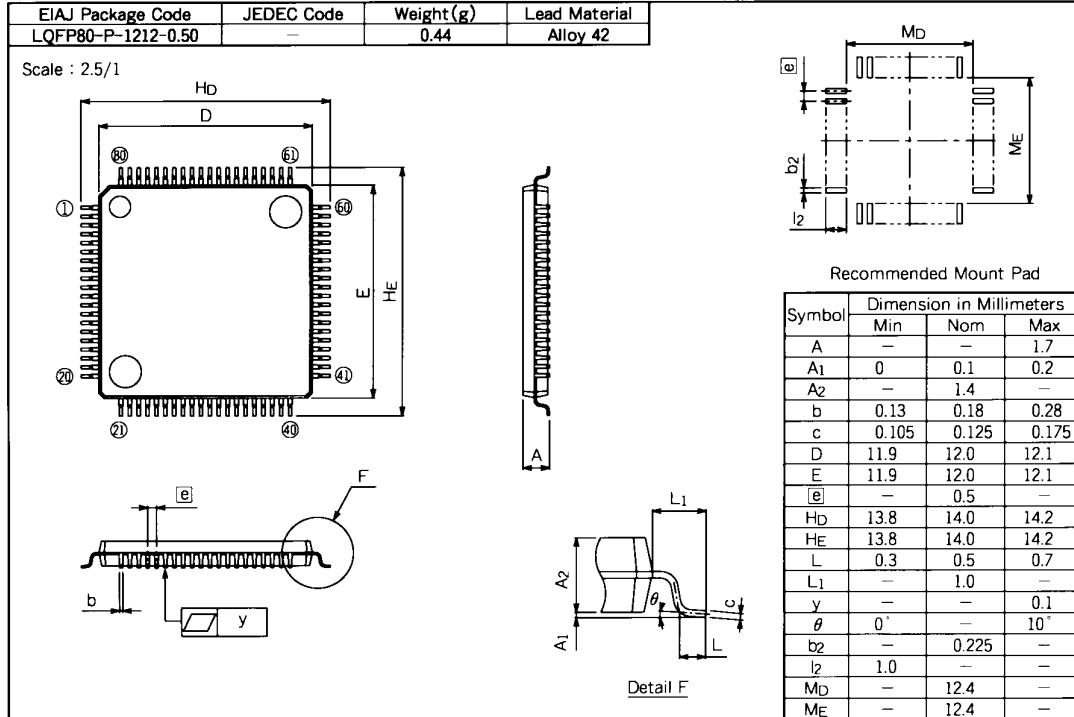

**7700 FAMILY MASK ROM ORDER CONFIRMATION FORM
SINGLE-CHIP 16-BIT MICROCOMPUTER
M37733M4LXXXHP
MITSUBISHI ELECTRIC**

Mask ROM number	
-----------------	--

Receipt	Date:	
	Section head signature	Supervisor signature

Note : Please fill in all items marked ※

※ Customer	Company name	TEL ()	Issuance signatures	Responsible officer	Supervisor
	Date issued	Date:			

※1. Confirmation

Specify the name of the product being ordered.

Three sets of EPROMs are required for each pattern (Check @ in the appropriate box).

If at least two of the three sets of EPROMs submitted contain the identical data, we will produce masks based on this data.

We shall assume the responsibility for errors only if the mask ROM data on the products we produce differ from this data.

Thus, the customer must be especially careful in verifying the data contained in the EPROMs submitted.

Checksum code for entire EPROM areas

--	--	--	--

 (hexadecimal notation)

EPROM Type :

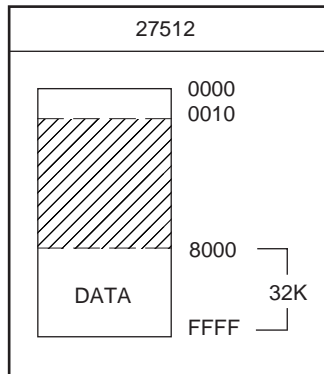

(1) Set "FF16" in the shaded area.

(2) Address 016 to 1016 are the area for storing the data on model designation and options. This area must be written with the data shown below.

Details for option data are given next in the section describing the STP instruction option.

Address and data are written in hexadecimal notation.

Address	Address	Address
4D 0	4C 8	Option data 10
33 1	FF 9	
37 2	FF A	
37 3	FF B	
33 4	FF C	
33 5	FF D	
4D 6	FF E	
34 7	FF F	

※2. STP instruction option

One of the following sets of data should be written to the option data address (1016) of the EPROM you have ordered.

Check @ in the appropriate box.

- STP instruction enable

0116

 Address 1016
- STP instruction disable

0016

 Address 1016

※3. Mark specification

Mark specification must be submitted using the correct form for the type of package being ordered fill out the appropriate 80P6D Mark Specification Form (for M37733M4LXXXHP) and attach to the Mask ROM Order Confirmation Form.

※4. Comments

80P6S (80-PIN QFP) MARK SPECIFICATION FORM 80P6D, 80P6Q (80-PIN Fine-pitch QFP)

Mitsubishi IC catalog name

Please choose one of the marking types below (A, B, C), and enter the Mitsubishi IC catalog name and the special mark (if needed).

A. Standard Mitsubishi Mark

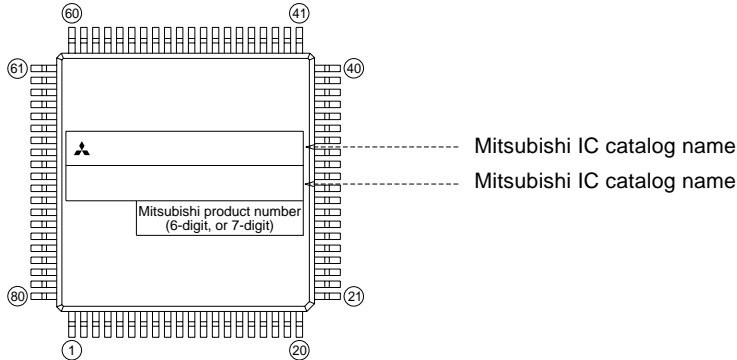

B. Customer's Parts Number + Mitsubishi IC Catalog Name

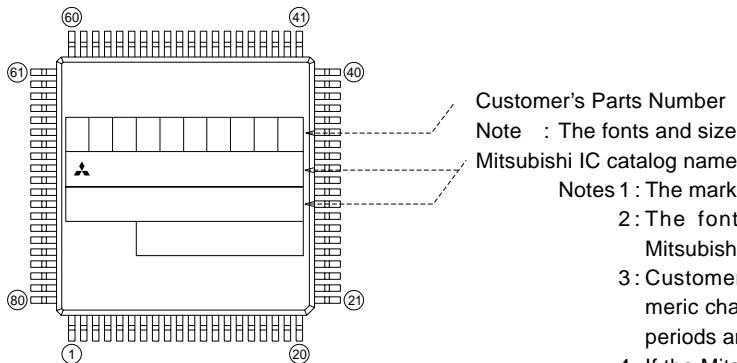

Customer's Parts Number

Note : The fonts and size of characters are standard Mitsubishi type.

Mitsubishi IC catalog name

Notes 1 : The mark field should be written right aligned.

2: The fonts and size of characters are standard Mitsubishi type.

3: Customer's parts number can be up to 10 alphanumeric characters for capital letters, hyphens, commas, periods and so on.

4: If the Mitsubishi logo is not required, check the box below.

Mitsubishi logo is not required

5: The allocation of Mitsubishi IC catalog name and Mitsubishi product number is different on the package owing to the number of Mitsubishi IC catalog name's characters, and the requiring Mitsubishi logo or not.

C. Special Mark Required

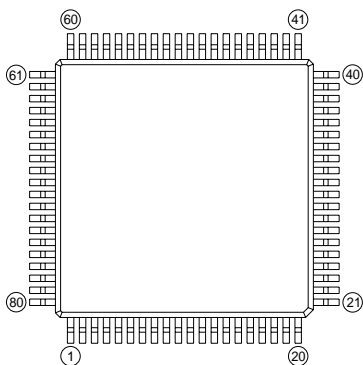

Notes 1: If Special mark is to be printed, indicate the desired layout of the mark in the left figure. The layout will be duplicated technically as close as possible. Mitsubishi product number (6-digit, or 7-digit) and Mask ROM number (3-digit) are always marked for sorting the products.

2: If special character fonts (e.g., customer's trade mark logo) must be used in Special Mark, check the box below.

For the new special character fonts, a clean font original (ideally logo drawing) must be submitted.

Special character fonts required

PRELIMINARY

Notice: This is not a final specification.
Some parametric limits are subject to change.

MITSUBISHI MICROCOMPUTERS

M37733M4LXXXHP

SINGLE-CHIP 16-BIT CMOS MICROCOMPUTER

Keep safety first in your circuit designs!

- Mitsubishi Electric Corporation puts the maximum effort into making semiconductor products better and more reliable, but there is always the possibility that trouble may occur with them. Trouble with semiconductors may lead to personal injury, fire or property damage. Remember to give due consideration to safety when making your circuit designs, with appropriate measures such as (i) placement of substitutive, auxiliary circuits, (ii) use of non-flammable material or (iii) prevention against any malfunction or mishap.

Notes regarding these materials

- These materials are intended as a reference to assist our customers in the selection of the Mitsubishi semiconductor product best suited to the customer's application; they do not convey any license under any intellectual property rights, or any other rights, belonging to Mitsubishi Electric Corporation or a third party.
- Mitsubishi Electric Corporation assumes no responsibility for any damage, or infringement of any third-party's rights, originating in the use of any product data, diagrams, charts or circuit application examples contained in these materials.
- All information contained in these materials, including product data, diagrams and charts, represent information on products at the time of publication of these materials, and are subject to change by Mitsubishi Electric Corporation without notice due to product improvements or other reasons. It is therefore recommended that customers contact Mitsubishi Electric Corporation or an authorized Mitsubishi Semiconductor product distributor for the latest product information before purchasing a product listed herein.
- Mitsubishi Electric Corporation semiconductors are not designed or manufactured for use in a device or system that is used under circumstances in which human life is potentially at stake. Please contact Mitsubishi Electric Corporation or an authorized Mitsubishi Semiconductor product distributor when considering the use of a product contained herein for any specific purposes, such as apparatus or systems for transportation, vehicular, medical, aerospace, nuclear, or undersea repeater use.
- The prior written approval of Mitsubishi Electric Corporation is necessary to reprint or reproduce in whole or in part these materials.
- If these products or technologies are subject to the Japanese export control restrictions, they must be exported under a license from the Japanese government and cannot be imported into a country other than the approved destination.
Any diversion or reexport contrary to the export control laws and regulations of Japan and/or the country of destination is prohibited.
- Please contact Mitsubishi Electric Corporation or an authorized Mitsubishi Semiconductor product distributor for further details on these materials or the products contained therein.

REVISION DESCRIPTION LIST

M37733M4LXXXHP DATA SHEET

Rev. No.	Revision Description	Rev. date
1.0	First Edition	970604
1.01	The following are added: <ul style="list-style-type: none">•MASK ROM ORDER CONFIRMATION FORM•MARK SPECIFICATION FORM	980526