

## Preliminary Specification

Specifications in this manual are tentative and subject to change

Mitsubishi microcomputers

**M30245 Group**



Features

SINGLE-CHIP 16-BIT CMOS MICROCOMPUTER

## 1.0 Description

The M30245 group is a 16-bit microcomputer based on the M16C family core technology that uses the high performance silicon gate CMOS process with an M16C/62 Series CPU core, and is packaged in a 100-pin, molded plastic QFP. They are single-chip USB peripheral microcontrollers meeting the Universal Serial Bus (USB) Version 1.1 specification. These microcontrollers operate using sophisticated instructions featuring a high level of instruction efficiency, making them capable of executing instructions at high speed.

### 1.1 Features

- Number of instructions ..... 91
- Shortest instruction execution time ..... 83ns ( $f(X_{IN})=12\text{MHz}$ ,  $V_{CC}=3\text{V}$  with no wait)
- USB Features:..... 5 endpoint pairs (IN/OUT)  
3.25K FIFO  
Integrated transceiver  
Conforms to USB V1.1 Specification
- Frequency Synthesizer..... PLL for 48MHz clock
- Memory capacity ..... 64KROM/5KRAM  
128KROM/10KRAM  
128K Flash /10K RAM
- Supply Voltage ..... 3.0 to 3.6V ( $f(X_{IN})=12\text{MHz}$ )
- Interrupts ..... 21 internal and 5 external interrupt sources  
4 software interrupt sources  
7 levels (including key input interrupt X 8)
- Multifunction 16-bit timer ..... 5 output timers+ 3 input timers
- UART ..... 3X7/8/9, 2X7/8/9/16/24/32 bits;  
Configurable for synchronous or asynchronous mode, I<sup>2</sup>S, I<sup>2</sup>C
- DMAC..... 4 channels
- A-D Converter ..... 10 bits X 8 channels
- CRC calculation circuit ..... 2 circuits with MSB/LSB selectable
- Watchdog timer ..... 1 line
- Key-on Wake up ..... 8 inputs
- Programmable I/O ..... 84 lines (TBD)
- Clock-generating circuit..... 2 built-in clock generation circuit  
(built-in feedback resistor, and external ceramic or quartz oscillator)

### 1.2 Applications

USB peripherals, such as telephones, audio systems, office equipment, communications equipment, portable equipment, scanners, and digital cameras.

Pin Configuration

**1.3 Pin Configuration**

Figure 1.1 shows the pin configuration (top view).

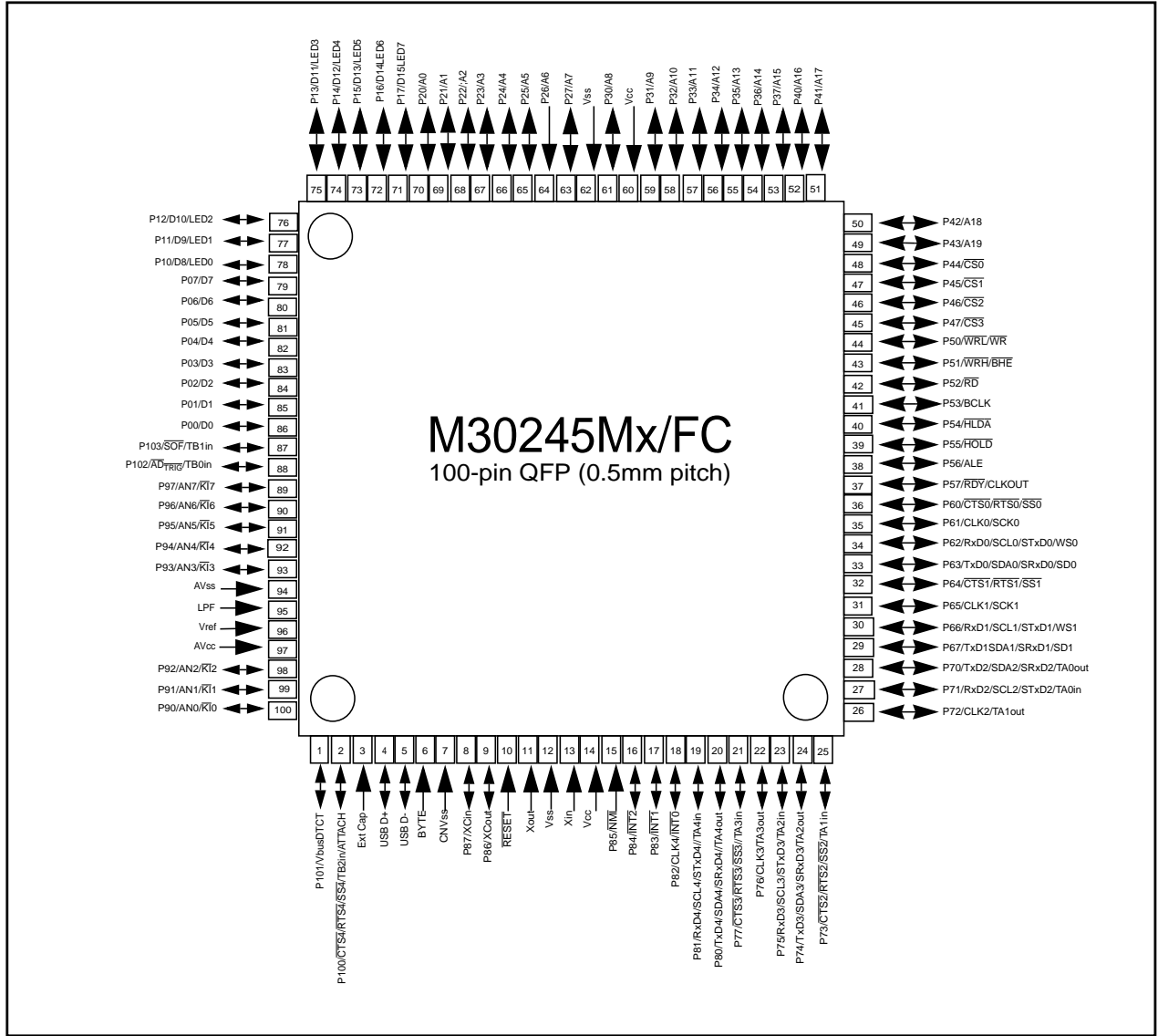

Figure 1.1: Pin Configuration (top view)

**Preliminary Specification**

Specifications in this manual are tentative and subject to change

Mitsubishi microcomputers

**M30245 Group**



Block Diagram

SINGLE-CHIP 16-BIT CMOS MICROCOMPUTER

**1.4 Block Diagram**

Figure 1.2 is a block diagram of the M30245 group.

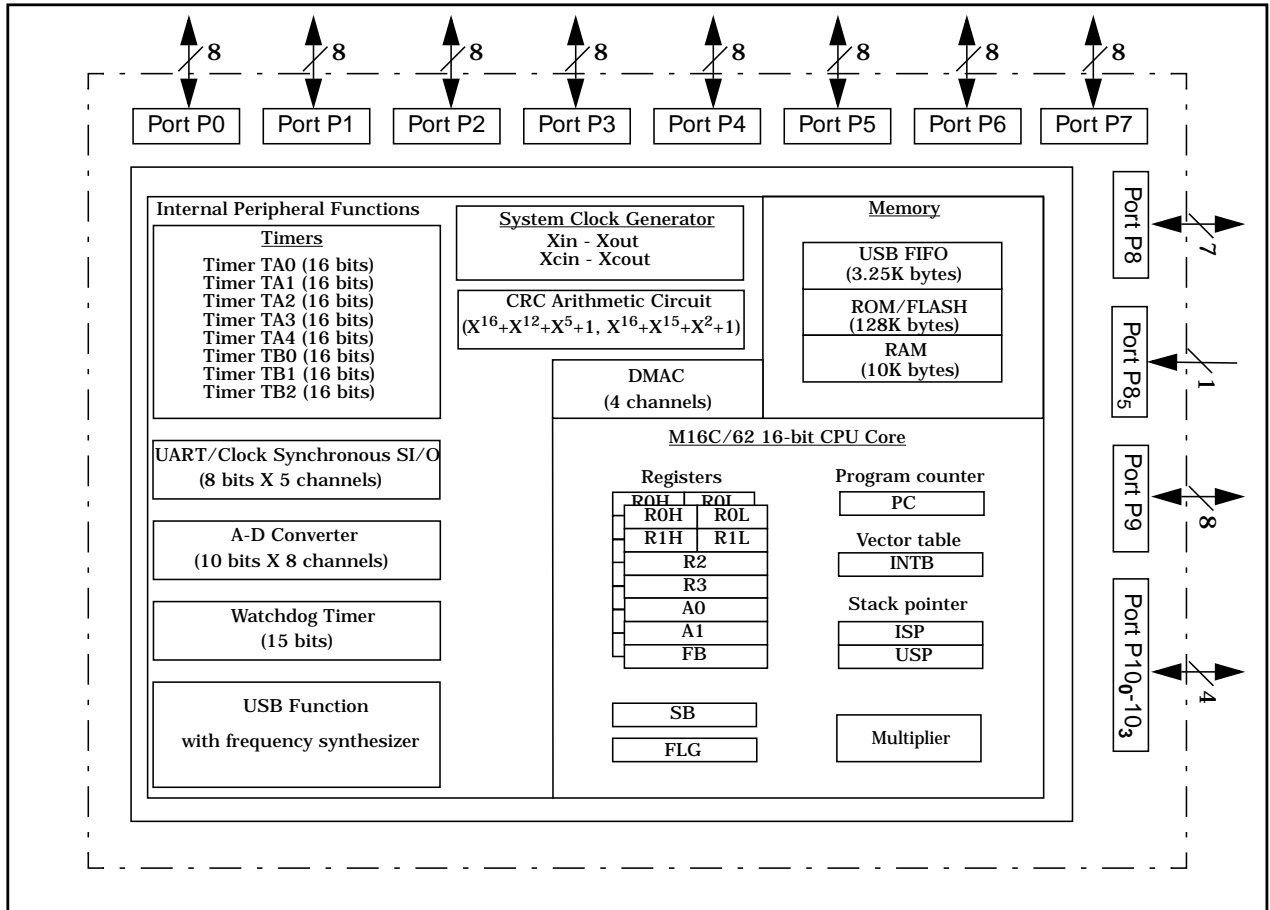

**Figure 1.2: Block diagram of M30245 group**

## Preliminary Specification

Specifications in this manual are tentative and subject to change

Mitsubishi microcomputers

**M30245 Group**



Performance outline

SINGLE-CHIP 16-BIT CMOS MICROCOMPUTER

### 1.5 Performance outline

Table 1.1 is a performance outline of the M30245 group.

**Table 1.1: Performance outline of M16C/M30245 Group**

Parameters		Function Description
Number of basic Instructions		91
Shortest Instruction execution time		83 ns $f(X_{in})= 12$ MHz, $V_{cc} = 3V$
Memory size	ROM	128/64 Kbytes
	RAM	10/5 Kbytes
Input/Output ports	P0~P9	I/O 8 bits x 10
	P100~P101	I/O 2 bits x 1
Multifunction timer	TA0, TA1, TA2, TA3, TA4	16 bits x 5
	TB0, TB1, TB2	16 bits x 3
Serial I/O	UART0~1	UART (or clock synchronous or IIS) x 2
	UART2~4	UART (or clock synchronous) x 3
A-D converter		10 bits x 8 channels
DMAC		4 channels
CRC calculation circuits		CRC-CCITT and CRC-16
Watchdog timer		15 bits x 1 (prescaler)
Interrupts		21 internal, 4 external sources, 4 software, 7 levels
Clock-generating circuit		2 built-in clock generating circuit
Supply voltage		3.0 ~ 3.6V, $f(X_{IN}) = 12$ MHz
Power consumption		TBD
I/O characteristics	I/O withstand voltage	3V
	Output current	5mA (20mA available on P1, P70, P72, P74, P76, P80)
Operating temperature		-20 to 85 C
Device configuration		CMOS high performance silicon gate
Package		100-pin plastic mold QFP

## Preliminary Specification

Specifications in this manual are tentative and subject to change

Mitsubishi microcomputers

**M30245 Group**



### Performance outline

SINGLE-CHIP 16-BIT CMOS MICROCOMPUTER

Mitsubishi plans to release the following products in the M30245 group:

- (1) Support for Flash memory version and mask ROM versions
- (2) ROM capacity: 128 or 64 Kbytes
- (3) Package
  - 100P6Q-A: Plastic molded QFP

Figure 1.3 shows the type number, memory size and package for the M30245 group.

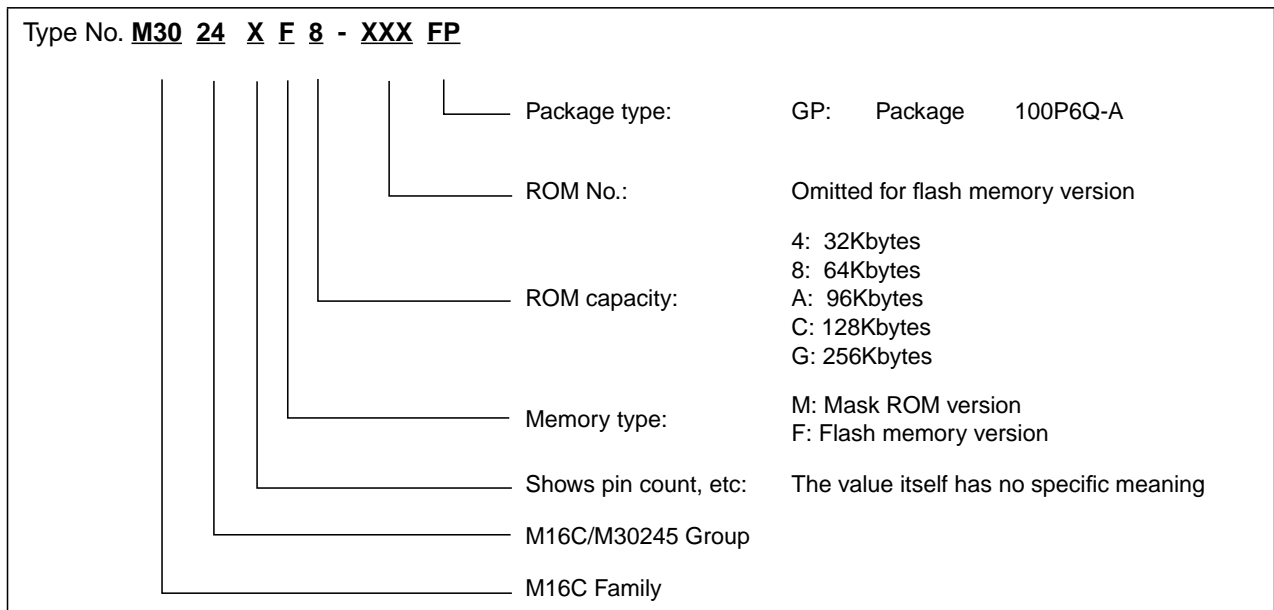

**Figure 1.3: Type number, memory size, and package**

Table 1.2 shows the package number, type, ROM and RAM capacity for M30245 Group.

**Table 1.2: M30245 Group**

Type	ROM Capacity	RAM Capacity	Package Type	Remarks
M30245FCGP	128K bytes	10K bytes	100P6Q-A	Flash ROM Version
M30245MCGP	128K bytes	10K bytes	100P6Q-A	Mask ROM Version
M30245M8GP	64K bytes	5K bytes	100P6Q-A	Mask ROM Version

SFR MAP

**1.6 SFR MAP**

The table below shows the peripheral control registers, their addresses, names, acronyms, and values after reset.

Address	Register name	Acronym	Value after reset
000 <sub>16</sub>			
0001 <sub>16</sub>			
0002 <sub>16</sub>			
0003 <sub>16</sub>			
0004 <sub>16</sub>	Processor mode register 0	PM0	00 <sub>16</sub>
0005 <sub>16</sub>	Processor mode register 1	PM1	0 0 <span style="background-color: #cccccc;">          </span> 0
0006 <sub>16</sub>	System clock control register 0	CM0	48 <sub>16</sub>
0007 <sub>16</sub>	System clock control register 1	CM1	20 <sub>16</sub>
0008 <sub>16</sub>	Chip select control register	CSR	0 0 0 0 0 0 0 1
0009 <sub>16</sub>	Address match interrupt enable register	AIER	<span style="background-color: #cccccc;">          </span> 0 0
000A <sub>16</sub>	Protect register	PRCR	<span style="background-color: #cccccc;">          </span> 0 0 0
000B <sub>16</sub>	Data bank register	DBR	<span style="background-color: #cccccc;">          </span> 1 1 1 0
000C <sub>16</sub>	USB control register	USBC	00 <sub>16</sub>
000D <sub>16</sub>			
000E <sub>16</sub>	Watchdog timer start register	WDTS	
000F <sub>16</sub>	Watchdog timer control register	WDC	0 0 0 ? ? ? ? ?
0010 <sub>16</sub>			00 <sub>16</sub>
0011 <sub>16</sub>	Address match interrupt register 0	RMAD0	00 <sub>16</sub>
0012 <sub>16</sub>			<span style="background-color: #cccccc;">          </span> 0 0 0 0
0013 <sub>16</sub>			
0014 <sub>16</sub>			00 <sub>16</sub>
0015 <sub>16</sub>	Address match interrupt register 1	RMAD1	00 <sub>16</sub>
0016 <sub>16</sub>			<span style="background-color: #cccccc;">          </span> 0 0 0 0
0017 <sub>16</sub>			
0018 <sub>16</sub>			
0019 <sub>16</sub>			
001A <sub>16</sub>			
001B <sub>16</sub>			
001C <sub>16</sub>			
001D <sub>16</sub>			
001E <sub>16</sub>	Reserved		
001F <sub>16</sub>	USB Attach/Detach register		00 <sub>16</sub>
0020 <sub>16</sub>			
0021 <sub>16</sub>	DMA0 source pointer	SAR0	
0022 <sub>16</sub>			
0023 <sub>16</sub>			
0024 <sub>16</sub>			
0025 <sub>16</sub>	DMA0 destination pointer	DAR0	
0026 <sub>16</sub>			
0027 <sub>16</sub>			
0028 <sub>16</sub>			
0029 <sub>16</sub>	DMA0 transfer counter	TCR0	
002A <sub>16</sub>			
002B <sub>16</sub>			
002C <sub>16</sub>	DMA0 control register	DM0CON	0 0 0 0 0 ? 0 0
002D <sub>16</sub>			
002E <sub>16</sub>			
002F <sub>16</sub>			
0030 <sub>16</sub>			
0031 <sub>16</sub>	DMA1 source pointer	SAR1	
0032 <sub>16</sub>			
0033 <sub>16</sub>			
0034 <sub>16</sub>			
0035 <sub>16</sub>	DMA1 destination pointer	DAR1	
0036 <sub>16</sub>			
0037 <sub>16</sub>			
0038 <sub>16</sub>			
0039 <sub>16</sub>	DMA1 transfer counter	TCR1	
003A <sub>16</sub>			
003B <sub>16</sub>			
003C <sub>16</sub>	DMA1 control register	DM1CON	0 0 0 0 0 ? 0 0
003D <sub>16</sub>	DMA2 interrupt control register	DM2IC	<span style="background-color: #cccccc;">          </span> ? 0 0 0
003E <sub>16</sub>	DMA3 interrupt control register	DM3IC	<span style="background-color: #cccccc;">          </span> ? 0 0 0
003F <sub>16</sub>	USB function interrupt control register	USBFIC	<span style="background-color: #cccccc;">          </span> ? 0 0 0

**Preliminary Specification**

*Specifications in this manual are tentative and subject to change*

Mitsubishi microcomputers

**M30245 Group**



**SFR MAP**

**SINGLE-CHIP 16-BIT CMOS MICROCOMPUTER**

Address	Register name	Acronym	Value after reset
0040 <sub>16</sub>	USB SOF interrupt control register	SOFIC	? 0 0 0
0041 <sub>16</sub>	Suspend interrupt control register	SUSPIC	? 0 0 0
0042 <sub>16</sub>	Reset interrupt control register	RSTIC	? 0 0 0
0043 <sub>16</sub>	Resume interrupt control register	RSMIC	? 0 0 0
0044 <sub>16</sub>	UART0/1 Bus collision interrupt control register	S01BCNIC	? 0 0 0
0045 <sub>16</sub>	UART2 Bus collision interrupt control register	S2BCNIC	? 0 0 0
0046 <sub>16</sub>	UART4 transmit interrupt control register	S4TIC	? 0 0 0
0047 <sub>16</sub>	UART4 receive interrupt control register	S4RIC	? 0 0 0
0048 <sub>16</sub>	UART3 transmit interrupt control register	S3TIC	? 0 0 0
0049 <sub>16</sub>	UART3 receive interrupt control register	S3RIC	? 0 0 0
004A <sub>16</sub>	UART3/4 Bus collision interrupt control register	S34BCNIC	? 0 0 0
004B <sub>16</sub>	DMA0 interrupt control register	DM0IC	? 0 0 0
004C <sub>16</sub>	DMA1 interrupt control register	DM1IC	? 0 0 0
004D <sub>16</sub>	Key input interrupt control register	KUPIC	? 0 0 0
004E <sub>16</sub>	A-D conversion interrupt control register	ADIC	? 0 0 0
004F <sub>16</sub>	UART2 transmit interrupt control register	S2TIC	? 0 0 0
0050 <sub>16</sub>	UART2 receive interrupt control register	S2RIC	? 0 0 0
0051 <sub>16</sub>	UART0 transmit interrupt control register	S0TIC	? 0 0 0
0052 <sub>16</sub>	UART0 receive interrupt control register	S0RIC	? 0 0 0
0053 <sub>16</sub>	UART1 transmit interrupt control register	S1TIC	? 0 0 0
0054 <sub>16</sub>	UART1 receive interrupt control register	S1RIC	? 0 0 0
0055 <sub>16</sub>	TIMER A0 interrupt control register	TA0IC	? 0 0 0
0056 <sub>16</sub>	TIMER A1 interrupt control register	TA1IC	? 0 0 0
0057 <sub>16</sub>	TIMER A2 interrupt control register	TA2IC	? 0 0 0
0058 <sub>16</sub>	TIMER A3 interrupt control register	TA3IC	? 0 0 0
0059 <sub>16</sub>	TIMER A4 interrupt control register	TA4IC	? 0 0 0
005A <sub>16</sub>	TIMER B0 interrupt control register	TB0IC	? 0 0 0
005B <sub>16</sub>	TIMER B1 interrupt control register	TB1IC	? 0 0 0
005C <sub>16</sub>	TIMER B2 interrupt control register	TB2IC	? 0 0 0
005D <sub>16</sub>	INT0 interrupt control register	INT0IC	0 0 ? 0 0 0
005E <sub>16</sub>	INT1 interrupt control register	INT1IC	0 0 ? 0 0 0
005F <sub>16</sub>	INT2 interrupt control register	INT2IC	0 0 ? 0 0 0
0060 <sub>16</sub>			
0061 <sub>16</sub>	DMA2 source pointer	SAR2	
0062 <sub>16</sub>			
0063 <sub>16</sub>			
0064 <sub>16</sub>			
0065 <sub>16</sub>	DMA2 destination pointer	DAR2	
0066 <sub>16</sub>			
0067 <sub>16</sub>			
0068 <sub>16</sub>	DMA2 transfer counter	TCR2	
0069 <sub>16</sub>			
006A <sub>16</sub>			
006B <sub>16</sub>			
006C <sub>16</sub>	DMA2 control register	DM2CON	0 0 0 0 0 ? 0 0
006D <sub>16</sub>			
006E <sub>16</sub>			
006F <sub>16</sub>			
0070 <sub>16</sub>			
0071 <sub>16</sub>	DMA3 source pointer	SAR3	
0072 <sub>16</sub>			
0073 <sub>16</sub>			
0074 <sub>16</sub>			
0075 <sub>16</sub>	DMA3 destination pointer	DAR3	
0076 <sub>16</sub>			
0077 <sub>16</sub>			
0078 <sub>16</sub>			
0079 <sub>16</sub>	DMA3 transfer counter	TCR3	
007A <sub>16</sub>			
007B <sub>16</sub>			
007C <sub>16</sub>	DMA3 control register	DM3CON	0 0 0 0 0 ? 0 0
007D <sub>16</sub>			
007E <sub>16</sub>			
007F <sub>16</sub>			



Address	Register name	Acronym	Value after reset
0280 <sub>16</sub>	USB address register	USBA	00 <sub>16</sub>
0281 <sub>16</sub>			
0282 <sub>16</sub>	USB poer management register	USBPM	00 <sub>16</sub>
0283 <sub>16</sub>			
0284 <sub>16</sub>	USB interrupt status register 1	USBIS0	00 <sub>16</sub>
0285 <sub>16</sub>			
0286 <sub>16</sub>	USB interrupt status register 1	USBIS1	00 <sub>16</sub>
0287 <sub>16</sub>			
0288 <sub>16</sub>	USB interrupt enable register	USBER	33FF <sub>16</sub>
0289 <sub>16</sub>			
028A <sub>16</sub>	USB frame number register low	USBSOF	0000 <sub>16</sub>
028B <sub>16</sub>			
028C <sub>16</sub>	USB ISO control register	USBISOC	0 0
028D <sub>16</sub>			
028E <sub>16</sub>	USB endpoint enable	USBEPEN	? 0 0 0
028F <sub>16</sub>			
0290 <sub>16</sub>	USB DMA0 source register	USBSAR0	00 <sub>16</sub>
0291 <sub>16</sub>			
0292 <sub>16</sub>	USB DMA1 source register	USBSAR1	00 <sub>16</sub>
0293 <sub>16</sub>			
0294 <sub>16</sub>	USB DMA2 source register	USBSAR2	00 <sub>16</sub>
0295 <sub>16</sub>			
0296 <sub>16</sub>	USB DMA3 source register	USBSAR3	00 <sub>16</sub>
0297 <sub>16</sub>			
0298 <sub>16</sub>	USB EP0 control/status register		00 <sub>16</sub>
0299 <sub>16</sub>			
029A <sub>16</sub>	USB EP0 max packet size register		08 <sub>16</sub>
029B <sub>16</sub>			
029C <sub>16</sub>	USB EP0 write count register		00 <sub>16</sub>
029D <sub>16</sub>			
029E <sub>16</sub>	USB EP1 IN control/status register		00 <sub>16</sub>
029F <sub>16</sub>			
02A0 <sub>16</sub>	USB EP1 IN max packet size register		00 <sub>16</sub>
02A1 <sub>16</sub>			
02A2 <sub>16</sub>	USB EP1 IN FIFO configuration register		
02A3 <sub>16</sub>			
02A4 <sub>16</sub>	USB EP2 IN control/status register		00 <sub>16</sub>
02A5 <sub>16</sub>			
02A6 <sub>16</sub>	USB EP2 IN max packet size register		00 <sub>16</sub>
02A7 <sub>16</sub>			
02A8 <sub>16</sub>	USB EP2 IN FIFO configuration register		
02A9 <sub>16</sub>			
02AA <sub>16</sub>	USB EP3 IN control/status register		00 <sub>16</sub>
02AB <sub>16</sub>			
02AC <sub>16</sub>	USB EP3 IN max packet size register		00 <sub>16</sub>
02AD <sub>16</sub>			
02AE <sub>16</sub>	USB EP3 IN FIFO configuration register		
02AF <sub>16</sub>			
02B0 <sub>16</sub>	USB EP4 IN control/status register		00 <sub>16</sub>
02B1 <sub>16</sub>			
02B2 <sub>16</sub>	USB EP4 IN max packet size register		00 <sub>16</sub>
02B3 <sub>16</sub>			
02B4 <sub>16</sub>	USB EP4 IN FIFO configuration register		
02B5 <sub>16</sub>			
02B6 <sub>16</sub>	USB EP1 OUT control/status register		00 <sub>16</sub>
02B7 <sub>16</sub>			
02B8 <sub>16</sub>	USB EP1 OUT max packet size register		00 <sub>16</sub>
02B9 <sub>16</sub>			
02BA <sub>16</sub>	USB EP1 OUT write count register		00 <sub>16</sub>
02BB <sub>16</sub>			
02BC <sub>16</sub>	USB EP1 OUT FIFO configuration register		00 <sub>16</sub>
02BD <sub>16</sub>			
02BE <sub>16</sub>	USB reserved		
02BF <sub>16</sub>	USB reserved		



**Preliminary Specification**

*Specifications in this manual are tentative and subject to change*

Mitsubishi microcomputers

**M30245 Group**



**SFR MAP**

**SINGLE-CHIP 16-BIT CMOS MICROCOMPUTER**

Address	Register name	Acronym	Value after reset
02C0 <sub>16</sub>	USB EP2 OUT control/status register		00 <sub>16</sub>
02C1 <sub>16</sub>			
02C2 <sub>16</sub>	USB EP2 OUT max packet size register		00 <sub>16</sub>
02C3 <sub>16</sub>			
02C4 <sub>16</sub>	USB EP2 OUT write count register		00 <sub>16</sub>
02C5 <sub>16</sub>			
02C6 <sub>16</sub>	USB EP2 OUT FIFO configuration register		
02C7 <sub>16</sub>			
02C8 <sub>16</sub>	USB EP3 OUT control/status register		00 <sub>16</sub>
02C9 <sub>16</sub>			
02CA <sub>16</sub>	USB EP3 OUT max packet size register		00 <sub>16</sub>
02CB <sub>16</sub>			
02CC <sub>16</sub>	USB EP3 OUT write count register		00 <sub>16</sub>
02CD <sub>16</sub>			
02CE <sub>16</sub>	USB EP3 OUT FIFO configuration register		
02CF <sub>16</sub>			
02D0 <sub>16</sub>	USB EP4 OUT control/status register		00 <sub>16</sub>
02D1 <sub>16</sub>			
02D2 <sub>16</sub>	USB EP4 OUT max packet size register		00 <sub>16</sub>
02D3 <sub>16</sub>			
02D4 <sub>16</sub>	USB EP4 OUT write count register		00 <sub>16</sub>
02D5 <sub>16</sub>			
02D6 <sub>16</sub>	USB EP4 OUT FIFO configuration register		
02D7 <sub>16</sub>			
02D8 <sub>16</sub>	USB reserved		
02D9 <sub>16</sub>	USB reserved		
02DA <sub>16</sub>	USB reserved		
02DB <sub>16</sub>	USB reserved		
02DC <sub>16</sub>	USB reserved		
02DD <sub>16</sub>	USB reserved		
02DE <sub>16</sub>	USB reserved		
02DF <sub>16</sub>	USB reserved		
02E0 <sub>16</sub>	USB EP0 IN FIFO		
02E1 <sub>16</sub>			
02E2 <sub>16</sub>	USB EP0 OUT FIFO		
02E3 <sub>16</sub>			
02E4 <sub>16</sub>	USB EP1 IN FIFO		
02E5 <sub>16</sub>			
02E6 <sub>16</sub>	USB EP1 OUT FIFO		
02E7 <sub>16</sub>			
02E8 <sub>16</sub>	USB EP2 IN FIFO		
02E9 <sub>16</sub>			
02EA <sub>16</sub>	USB EP2 OUT FIFO		
02EB <sub>16</sub>			
02EC <sub>16</sub>	USB EP3 IN FIFO		
02ED <sub>16</sub>			
02EE <sub>16</sub>	USB EP3 OUT FIFO		
02EF <sub>16</sub>			
02F0 <sub>16</sub>	USB EP4 IN FIFO		
02F1 <sub>16</sub>			
02F2 <sub>16</sub>	USB EP4 OUT FIFO		
02F3 <sub>16</sub>			
02F4 <sub>16</sub>			
02F5 <sub>16</sub>			
02F6 <sub>16</sub>			
02F7 <sub>16</sub>			
02F8 <sub>16</sub>			
02F9 <sub>16</sub>			
02FA <sub>16</sub>			
02FB <sub>16</sub>			
02FC <sub>16</sub>			
02FD <sub>16</sub>			
02FE <sub>16</sub>			
02FF <sub>16</sub>			

**Preliminary Specification**  
*Specifications in this manual are tentative and subject to change*

SFR MAP

Address	Register name	Acronym	Value after reset	
0300 <sub>16</sub>				
0301 <sub>16</sub>				
0302 <sub>16</sub>				
0303 <sub>16</sub>				
0304 <sub>16</sub>				
0305 <sub>16</sub>				
0306 <sub>16</sub>				
0307 <sub>16</sub>				
0308 <sub>16</sub>				
0309 <sub>16</sub>				
030A <sub>16</sub>				
030B <sub>16</sub>				
030C <sub>16</sub>				
030D <sub>16</sub>				
030E <sub>16</sub>				
030F <sub>16</sub>				
0310 <sub>16</sub>				
0311 <sub>16</sub>				
0312 <sub>16</sub>				
0313 <sub>16</sub>				
0314 <sub>16</sub>	UART4 special mode register 4	U4SMR4	00 <sub>16</sub>	
0315 <sub>16</sub>	UART4 special mode register 3	U4SMR3	00 <sub>16</sub>	
0316 <sub>16</sub>	UART4 special mode register 2	U4SMR2	00 <sub>16</sub>	
0317 <sub>16</sub>	UART4 special mode register	U4SMR	00 <sub>16</sub>	
0318 <sub>16</sub>	UART4 transmit / receive mode register	U4MR	00 <sub>16</sub>	
0319 <sub>16</sub>	UART4 bit rate generator	U4BRG		
031A <sub>16</sub>				
031B <sub>16</sub>	UART4 transmit buffer register	U4TB		
031C <sub>16</sub>	UART4 transmit / receive control register 0	U4C0	08 <sub>16</sub>	
031D <sub>16</sub>	UART4 transmit / receive control register 1	U4C1	02 <sub>16</sub>	
031E <sub>16</sub>				
031F <sub>16</sub>	UART4 receive buffer register	U4RB		
0320 <sub>16</sub>				
0321 <sub>16</sub>				
0322 <sub>16</sub>				
0323 <sub>16</sub>				
0324 <sub>16</sub>	UART3 special mode register 4	U3SMR4	00 <sub>16</sub>	
0325 <sub>16</sub>	UART3 special mode register 3	U3SMR3	00 <sub>16</sub>	
0326 <sub>16</sub>	UART3 special mode register 2	U3SMR2	00 <sub>16</sub>	
0327 <sub>16</sub>	UART3 special mode register	U3SMR	00 <sub>16</sub>	
0328 <sub>16</sub>	UART3 transmit / receive mode register	U3MR	00 <sub>16</sub>	
0329 <sub>16</sub>	UART3 bit rate generator	U3BRG		
032A <sub>16</sub>				
032B <sub>16</sub>	UART3 transmit buffer register	U3TB		
032C <sub>16</sub>	UART3 transmit / receive control register 0	U3C0	08 <sub>16</sub>	
032D <sub>16</sub>	UART3 transmit / receive control register 1	U3C1	02 <sub>16</sub>	
032E <sub>16</sub>				
032F <sub>16</sub>	UART3 receive buffer register	U3RB		
0330 <sub>16</sub>				
0331 <sub>16</sub>				
0332 <sub>16</sub>				
0333 <sub>16</sub>				
0334 <sub>16</sub>	UART2 special mode register 4	U2SMR4	00 <sub>16</sub>	
0335 <sub>16</sub>	UART2 special mode register 3	U2SMR3	00 <sub>16</sub>	
0336 <sub>16</sub>	UART2 special mode register 2	U2SMR2	00 <sub>16</sub>	
0337 <sub>16</sub>	UART2 special mode register	U2SMR	00 <sub>16</sub>	
0338 <sub>16</sub>	UART2 transmit / receive mode register	U2MR	00 <sub>16</sub>	
0339 <sub>16</sub>	UART2 bit rate generator	U2BRG		
033A <sub>16</sub>				
033B <sub>16</sub>	UART2 transmit buffer register	U2TB		
033C <sub>16</sub>	UART2 transmit / receive control register 0	U2C0	08 <sub>16</sub>	
033D <sub>16</sub>	UART2 transmit / receive control register 1	U2C1	02 <sub>16</sub>	
033E <sub>16</sub>				
033F <sub>16</sub>	UART2 receive buffer register	U2RB		



Address	Register name	Acronym	Value after reset	
0340 <sub>16</sub>				
0341 <sub>16</sub>				
0342 <sub>16</sub>	Timer A1-1 register	TA11		
0343 <sub>16</sub>				
0344 <sub>16</sub>	Timer A1-2 register	TA12		
0345 <sub>16</sub>				
0346 <sub>16</sub>	Timer A1-3 register	TA13		
0347 <sub>16</sub>				
0348 <sub>16</sub>	Three-phase PWM control register 0	INVC0	00 <sub>16</sub>	
0349 <sub>16</sub>	Three-phase PWM control register 1	INVC1	0 0 0 0 ? 0 0 0	
034A <sub>16</sub>	Three-phase output buffer register 0	IDB0	00 <sub>16</sub>	
034B <sub>16</sub>	Three-phase output buffer register 1	IDB1	00 <sub>16</sub>	
034C <sub>16</sub>	Dead time timer	DTT		
034D <sub>16</sub>	Timer B2 interrupt occurrence frequency set counter	ICTB2		
034E <sub>16</sub>				
034F <sub>16</sub>				
0350 <sub>16</sub>				
0351 <sub>16</sub>				
0352 <sub>16</sub>				
0353 <sub>16</sub>				
0354 <sub>16</sub>				
0355 <sub>16</sub>				
0356 <sub>16</sub>				
0357 <sub>16</sub>				
0358 <sub>16</sub>				
0359 <sub>16</sub>				
035A <sub>16</sub>				
035B <sub>16</sub>				
035C <sub>16</sub>				
035D <sub>16</sub>				
035E <sub>16</sub>				
035F <sub>16</sub>	Interrupt cause select register	IFSR	00 <sub>16</sub>	
0360 <sub>16</sub>				
0361 <sub>16</sub>				
0362 <sub>16</sub>				
0363 <sub>16</sub>				
0364 <sub>16</sub>	UART1 special mode register 4	U1SMR4	00 <sub>16</sub>	
0365 <sub>16</sub>	UART1 special mode register 3	U1SMR3	00 <sub>16</sub>	
0366 <sub>16</sub>	UART1 special mode register 2	U1SMR2	00 <sub>16</sub>	
0367 <sub>16</sub>	UART1 special mode register	U1SMR	00 <sub>16</sub>	
0368 <sub>16</sub>	UART1 transmit / receive mode register	U1MR	00 <sub>16</sub>	
0369 <sub>16</sub>	UART1 bit rate generator	U1BRG		
036A <sub>16</sub>	UART1 transmit buffer register	U1TB		
036B <sub>16</sub>				
036C <sub>16</sub>	UART1 transmit / receive control register 0	U1C0	08 <sub>16</sub>	
036D <sub>16</sub>	UART1 transmit / receive control register 1	U1C1	02 <sub>16</sub>	
036E <sub>16</sub>	UART1 receive buffer register	U1RB		
036F <sub>16</sub>				
0370 <sub>16</sub>				
0371 <sub>16</sub>				
0372 <sub>16</sub>				
0373 <sub>16</sub>				
0374 <sub>16</sub>				
0375 <sub>16</sub>				
0376 <sub>16</sub>				
0377 <sub>16</sub>				
0378 <sub>16</sub>				
0379 <sub>16</sub>				
037A <sub>16</sub>				
037B <sub>16</sub>				
037C <sub>16</sub>				
037D <sub>16</sub>				
037E <sub>16</sub>				
037F <sub>16</sub>				

SFR MAP

Address	Register name	Acronym	Value after reset
0380 <sub>16</sub>	Count start flag	TABSR	00 <sub>16</sub>
0381 <sub>16</sub>	Clock prescaler reset flag	CPSRF	0
0382 <sub>16</sub>	One-shot start flag	ONSF	0 0 0 0 0 0 0
0383 <sub>16</sub>	Trigger select register	TRGSR	00 <sub>16</sub>
0384 <sub>16</sub>	Up-down flag	UDF	00 <sub>16</sub>
0385 <sub>16</sub>			
0386 <sub>16</sub>	Timer A0	TA0	
0387 <sub>16</sub>			
0388 <sub>16</sub>	Timer A1	TA1	
0389 <sub>16</sub>			
038A <sub>16</sub>	Timer A2	TA2	
038B <sub>16</sub>			
038C <sub>16</sub>	Timer A3	TA3	
038D <sub>16</sub>			
038E <sub>16</sub>	Timer A4	TA4	
038F <sub>16</sub>			
0390 <sub>16</sub>	Timer B0	TB0	
0391 <sub>16</sub>			
0392 <sub>16</sub>	Timer B1	TB1	
0393 <sub>16</sub>			
0394 <sub>16</sub>	Timer B2	TB2	
0395 <sub>16</sub>			
0396 <sub>16</sub>	Timer A0 mode register	TA0MR	00 <sub>16</sub>
0397 <sub>16</sub>	Timer A1 mode register	TA1MR	00 <sub>16</sub>
0398 <sub>16</sub>	Timer A2 mode register	TA2MR	00 <sub>16</sub>
0399 <sub>16</sub>	Timer A3 mode register	TA3MR	00 <sub>16</sub>
039A <sub>16</sub>	Timer A4 mode register	TA4MR	00 <sub>16</sub>
039B <sub>16</sub>	Timer B0 mode register	TB0MR	0 0 ? 0 0 0 0
039C <sub>16</sub>	Timer B1 mode register	TB1MR	0 0 ? 0 0 0 0
039D <sub>16</sub>	Timer B2 mode register	TB2MR	0 0 ? 0 0 0 0
039E <sub>16</sub>	Timer B2 special mode register	TB2SC	0
039F <sub>16</sub>	Timer count source prescaler	TCSPR	0 ? ? ? ?
03A0 <sub>16</sub>			
03A1 <sub>16</sub>			
03A2 <sub>16</sub>			
03A3 <sub>16</sub>			
03A4 <sub>16</sub>	UART0 special mode register 4	U0SMR4	00 <sub>16</sub>
03A5 <sub>16</sub>	UART0 special mode register 3	U0SMR3	00 <sub>16</sub>
03A6 <sub>16</sub>	UART0 special mode register 2	U0SMR2	00 <sub>16</sub>
03A7 <sub>16</sub>	UART0 special mode register	U0SMR	00 <sub>16</sub>
03A8 <sub>16</sub>	UART0 transmit / receive mode register	U0MR	00 <sub>16</sub>
03A9 <sub>16</sub>	UART0 bit rate generator	U0BRG	
03AA <sub>16</sub>	UART0 transmit buffer register	U0TB	
03AB <sub>16</sub>			
03AC <sub>16</sub>	UART0 transmit / receive control register 0	U0C0	08 <sub>16</sub>
03AD <sub>16</sub>	UART0 transmit / receive control register 1	U0C1	02 <sub>16</sub>
03AE <sub>16</sub>	UART0 receive buffer register	U0RB	
03AF <sub>16</sub>			
03B0 <sub>16</sub>	DMA2 cause select register	DM2SL	00 <sub>16</sub>
03B1 <sub>16</sub>			
03B2 <sub>16</sub>	DMA3 cause select register	DM3SL	00 <sub>16</sub>
03B3 <sub>16</sub>			
03B4 <sub>16</sub>			
03B5 <sub>16</sub>			
03B6 <sub>16</sub>			
03B7 <sub>16</sub>			
03B8 <sub>16</sub>	DMA0 cause select register	DM0SL	00 <sub>16</sub>
03B9 <sub>16</sub>			
03BA <sub>16</sub>	DMA1 cause select register	DM1SL	00 <sub>16</sub>
03BB <sub>16</sub>	CRC mode register	CRCMR	0
03BC <sub>16</sub>	CRC data register	CRCD	
03BD <sub>16</sub>	CRC input register	CRCIN	
03BE <sub>16</sub>			
03BF <sub>16</sub>			

# Preliminary Specification

Specifications in this manual are tentative and subject to change

Mitsubishi microcomputers

**M30245 Group**



## SFR MAP

SINGLE-CHIP 16-BIT CMOS MICROCOMPUTER

Address	Register name	Acronym	Value after reset
03C0 <sub>16</sub>	A-D register 0	AD0	
03C1 <sub>16</sub>			
03C2 <sub>16</sub>	A-D register 1	AD1	
03C3 <sub>16</sub>			
03C4 <sub>16</sub>	A-D register 2	AD2	
03C5 <sub>16</sub>			
03C6 <sub>16</sub>	A-D register 3	AD3	
03C7 <sub>16</sub>			
03C8 <sub>16</sub>	A-D register 4	AD4	
03C9 <sub>16</sub>			
03CA <sub>16</sub>	A-D register 5	AD5	
03CB <sub>16</sub>			
03CC <sub>16</sub>	A-D register 6	AD6	
03CD <sub>16</sub>			
03CE <sub>16</sub>	A-D register 7	AD7	
03CF <sub>16</sub>			
03D0 <sub>16</sub>			
03D1 <sub>16</sub>			
03D2 <sub>16</sub>			
03D3 <sub>16</sub>			
03D4 <sub>16</sub>	A-D control register 2	ADCON2	0
03D5 <sub>16</sub>			
03D6 <sub>16</sub>	A-D control register 0	ADCON0	0 0 0 0 0 ? ? ?
03D7 <sub>16</sub>	A-D control register 1	ADCON1	00 <sub>16</sub>
03D8 <sub>16</sub>			
03D9 <sub>16</sub>			
03DA <sub>16</sub>			
03DB <sub>16</sub>	Frequency synthesizer clock control	FSCCR	00 <sub>16</sub>
03DC <sub>16</sub>	Frequency synthesizer control	FSC	60 <sub>16</sub>
03DD <sub>16</sub>	Frequency synthesizer multiplier control	FSM	FF <sub>16</sub>
03DE <sub>16</sub>	Frequency synthesizer prescaler control	FSP	FF <sub>16</sub>
03DF <sub>16</sub>	Frequency synthesizer divider	FSD	FF <sub>16</sub>
03E0 <sub>16</sub>	Port P0	P0	
03E1 <sub>16</sub>	Port P1	P1	
03E2 <sub>16</sub>	Port P0 direction register	PD0	00 <sub>16</sub>
03E3 <sub>16</sub>	Port P1 direction register	PD1	00 <sub>16</sub>
03E4 <sub>16</sub>	Port P2	P2	
03E5 <sub>16</sub>	Port P3	P3	
03E6 <sub>16</sub>	Port P2 direction register	PD2	00 <sub>16</sub>
03E7 <sub>16</sub>	Port P3 direction register	PD3	00 <sub>16</sub>
03E8 <sub>16</sub>			
03E9 <sub>16</sub>			
03EA <sub>16</sub>			
03EB <sub>16</sub>			
03EC <sub>16</sub>	Port P6	P6	
03ED <sub>16</sub>	Port P7	P7	
03EE <sub>16</sub>	Port P6 direction register	PD6	00 <sub>16</sub>
03EF <sub>16</sub>	Port P7 direction register	PD7	00 <sub>16</sub>
03F0 <sub>16</sub>	Port P8	P8	
03F1 <sub>16</sub>			
03F2 <sub>16</sub>	Port P8 direction register	PD8	00 <sub>16</sub>
03F3 <sub>16</sub>			
03F4 <sub>16</sub>	Port P10	P10	
03F5 <sub>16</sub>			
03F6 <sub>16</sub>	Port P10 direction register	PD10	00 <sub>16</sub>
03F7 <sub>16</sub>			
03F8 <sub>16</sub>			
03F9 <sub>16</sub>			
03FA <sub>16</sub>	P2 drive capacity	P2DR	
03FB <sub>16</sub>	PWM drive capacity	PWMDR	
03FC <sub>16</sub>	Pull-up control register 0	PUR0	00 <sub>16</sub>
03FD <sub>16</sub>	Pull-up control register 1	PUR1	00 <sub>16</sub>
03FE <sub>16</sub>			
03FF <sub>16</sub>			