

PRELIMINARY
 Notices: This is not a final specification.
 Some parametric limits are subject to change.

M62262FP

VOLTAGE CONVERTER FOR MMIC

GENERAL DESCRIPTION

The M62262FP is a CMOS voltage converter for driving MMICs. It includes a input inverter utilizing a charge-pump technique, therefore it can provide both a just inverted output (-Vo) and a twice inverted output (-2Vo) by connecting an external capacitor. It can also switch over between a stand-by mode (a halt function with low power dissipation) and a double clocking mode for reducing output ripples.

FEATURE

- Availability of two outputs ; just inverted and twice inverted output
- Capability of output current ----- 30mA (min)
- Low voltage operation ----- Vin = 3V (typ)
- Low stand-by current (standby mode)
- Low out ripple (double clocking mode)
- Small 10-pin package

APPLICATION

- MMICs for a handy telephone and a PHS

PIN CONFIGURATION(TOP VIEW)

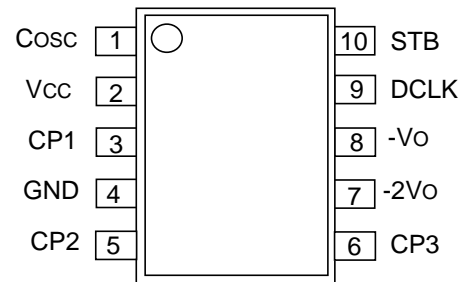

OUTLINE 10P2N

BLOCK DIAGRAM

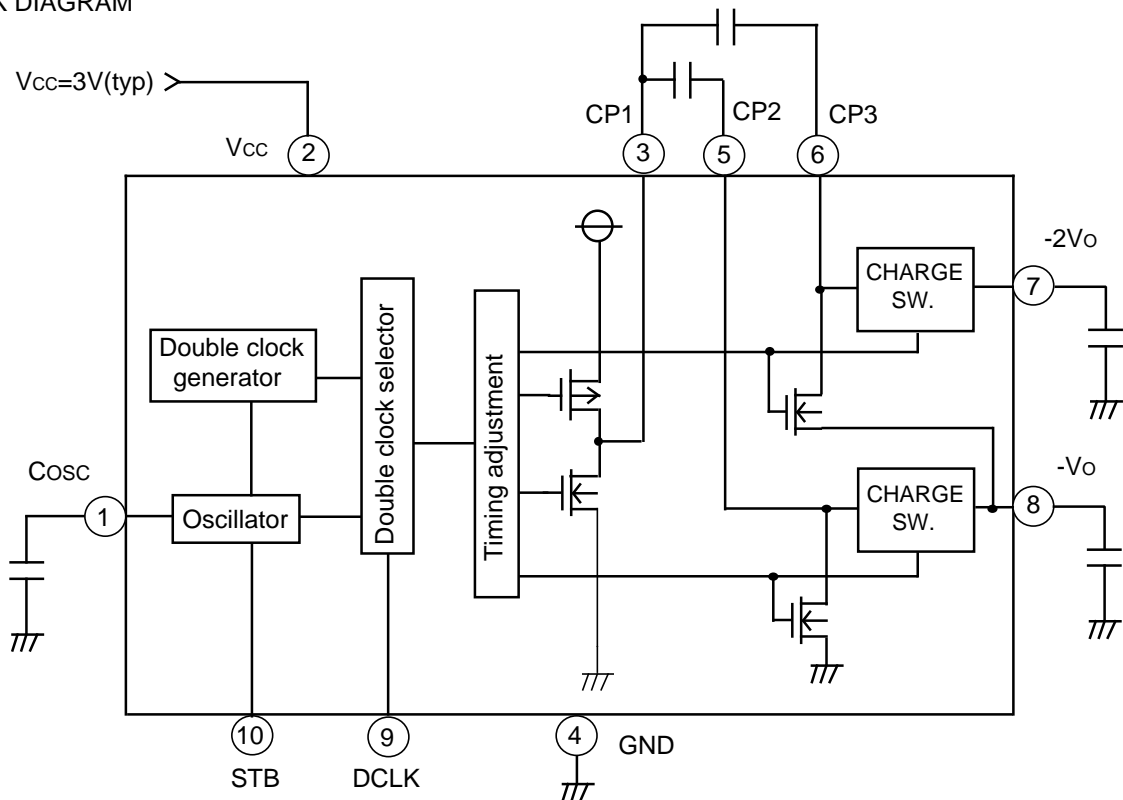

PRELIMINARY
 Notices: This is not a final specification.
 Some parametric limits are subject to change.

M62262FP

VOLTAGE CONVERTER FOR MMIC

FUNCTION DESCRIPTION OF EACH PIN

| PIN No. | SYMBOL | FUNCTION DESCRIPTION |
|---------|--------|--|
| 1 | Cosc | Connecting pin for capacitance of oscillator |
| 2 | Vcc | Input voltage |
| 3 | CP1 | Connecting pin 1 for a capacitor of charge-pump |
| 4 | GND | GND pin |
| 5 | CP2 | Connecting pin 2 for a capacitor of charge-pump |
| 6 | CP3 | Connecting pin 3 for a capacitor of charge-pump |
| 7 | -2Vo | 2-times inverted output |
| 8 | -Vo | Just inverted output |
| 9 | DCLK | Switchover between double clocking (H) and normal mode (L) |
| 10 | STB | Switchover between stand-by (H) and actual operation (L) |

ABSOLUTE MAXIMUM RATINGS(Ta=25°C unless otherwise noted)

| SYMBOL | PARAMETER | CONDITIONS | RATINGS | UNIT |
|--------------------|----------------------------|------------|-------------|------|
| Vcc | Supply voltage | | 6 | V |
| P _D | Internal power dissipation | | 440 | mW |
| T _{o p r} | Operating temperture | | - 20 ~ + 75 | °C |
| T _{s t g} | Storage temperture | | - 40 ~ +125 | °C |

ELECTRICAL CHARACTERISTICS (VIN =3V, Cosc=220PF, Ta=25°C, unless otherwise noted)

| SYMBOL | PARAMETER | CONDITIONS | RATINGS | | | UNIT |
|------------------|-------------------------------|---|------------|------|-----|------|
| | | | MIN | TYP | MAX | |
| I _{CC} | Dissipation current | | | 450 | 900 | μA |
| V _{CC} | Range of source voltage | | 2.7 | | 5.5 | V |
| RO1 | Output resistor | -Vout output pin (with load at -Vout pin only) | | 30 | 60 | |
| RO2 | | -2Vout output pin(with load at -2Vout pin only) | | 90 | 180 | |
| V _{EF} | Voltage conversion efficiency | No load | 95 | 99.8 | | % |
| PEF1 | Power efficiency | -Vout output pin , I _L =-5mA | | 90 | | |
| PEF2 | | -2Vout output pin , I _L =-5mA | | 90 | | |
| f _{OSC} | Oscillating frequency | COSC=220PF | 2 | 6 | 10 | kHz |
| DCLK | I _{CC} | DCLK=Vcc | | 0.6 | 1 | mA |
| | RO1 | -Vout output pin (with load at -Vout pin only) | | 20 | 40 | |
| | RO2 | -2Vout output pin(with load at -2Vout pin only) | | 60 | 120 | |
| | f _{OSC} | Standby current | COSC=220PF | 4 | 12 | 20 |
| ISTB | Standby current | STB=Vcc | | 2 | 5 | μA |

PRELIMINARY
Notices: This is not a final specification.
Some parametric limits are subject to change.

M62262FP

VOLTAGE CONVERTER FOR MMIC

AN EXAMPLE APPLICATION CIRCUIT

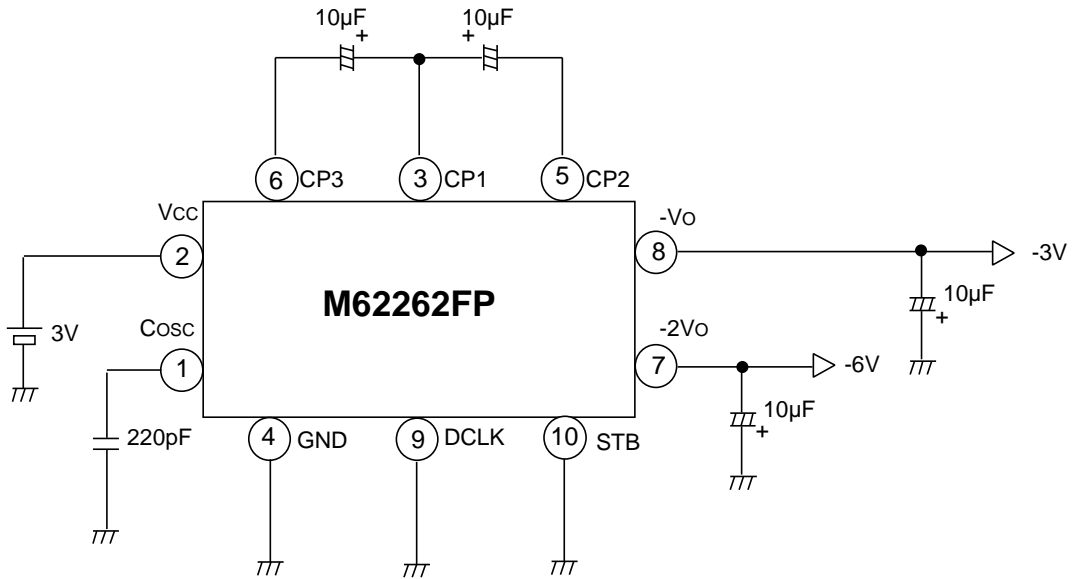

⚠ Mitsubishi Electric Corporation puts the maximum effort into making semiconductor products better and more reliable, but there is always the possibility that trouble may occur with them. Trouble with semiconductors may lead to personal injury, fire or property damage. Remember to give due consideration to safety when making your circuit design, in order to prevent fires from spreading, redundancy, malfunction or other mishap.