

MITSUBISHI <DIGITAL ASSP> M66503ASP/AGP

16-BIT CONSTANT CURRENT LED DRIVER with SHIFT REGISTER AND LATCH

DESCRIPTION

The M66503A is a constant current LED driver IC, whose output current is variable. The IC's functions include 16-bit serial input/parallel output shift register with output latch.

The product uses Bi-CMOS process for highly accurate constant current driving, permitting high-efficiency LED driving without using a resistor that limits LED current.

Settings for the LED drive current are made by an external resistor, thereby ensuring a maximum output current of 30 mA, enough for anode-common LED driving.

Furthermore, the pin configuration of the IC permits easier wiring on a printed board.

FEATURES

- Anode-common LED driving
- Constant current output: Set to a value within a range between 0 and 30mA with an external resistor only. Simultaneous lighting available.
- Pins (OEA, OEB) provided for forced ON/OFF of LED drive current.
- Greater noise margin: Total-input Schmitt circuit is employed to deal with longer wire lengths.
- Input/output CMOS compatible
- Serial data output provided (SQ15)
- 5V single power supply
- Pin configuration for easier wiring on printed board

APPLICATION

LED array drivers for display panel and printer. Other various LED modules.

FUNCTION

The M66503A is a constant current LED driver for anode-common LEDs. To set the LED driving current, an external resistor is connected between the current setting input pin, RC, and GND. In this way it is possible to set a highly accurate drive current. Each bit of the shift register is made up of a flip-flop performing shift function and a latch connected to the output. When the clock input pin, CKs, goes from "L" to "H", data is shifted. Serial data is entered to the shift register via the serial data input pin, A. Data on A is straight shifted. By turning the latch enable input pin, LE, to "L", the contents stored in the shift register is latched. All outputs are turned off if the output enable input pins, OEA and OEB, are simultaneously set to "L". This function is useful for the prevention of an excessive current flowing at the moment of power on. All outputs are turned on if the OEA pin is set to "H". This enables to check LEDs for failure. In these actions, changing the state of OEA and/or OEB does not affect the shift function. To expand the number of bits, link the M66503A in serial using the serial data output pin, SQ15, which is the serial data output of the shift register.

PIN CONFIGURATION (TOP VIEW)

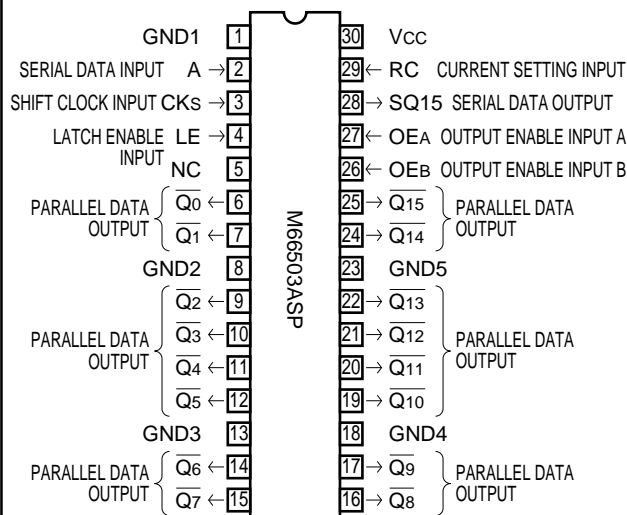

Outline 30P4B

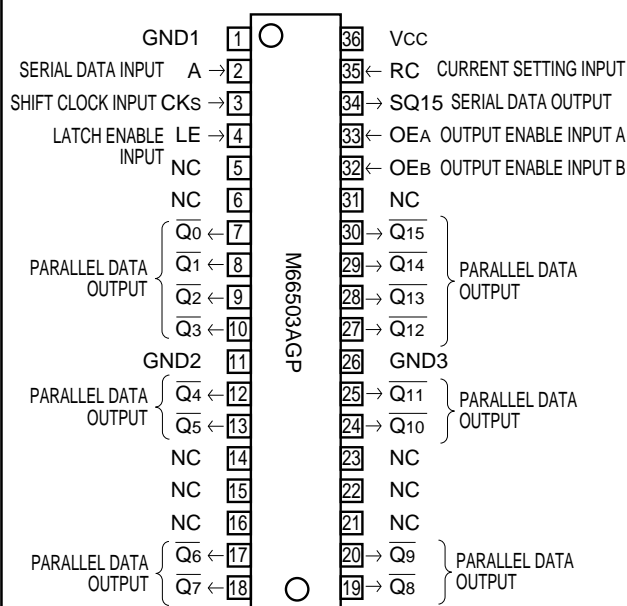

Outline 36P2R-D

NC: No Connection

16-BIT CONSTANT CURRENT LED DRIVER with SHIFT REGISTER AND LATCH

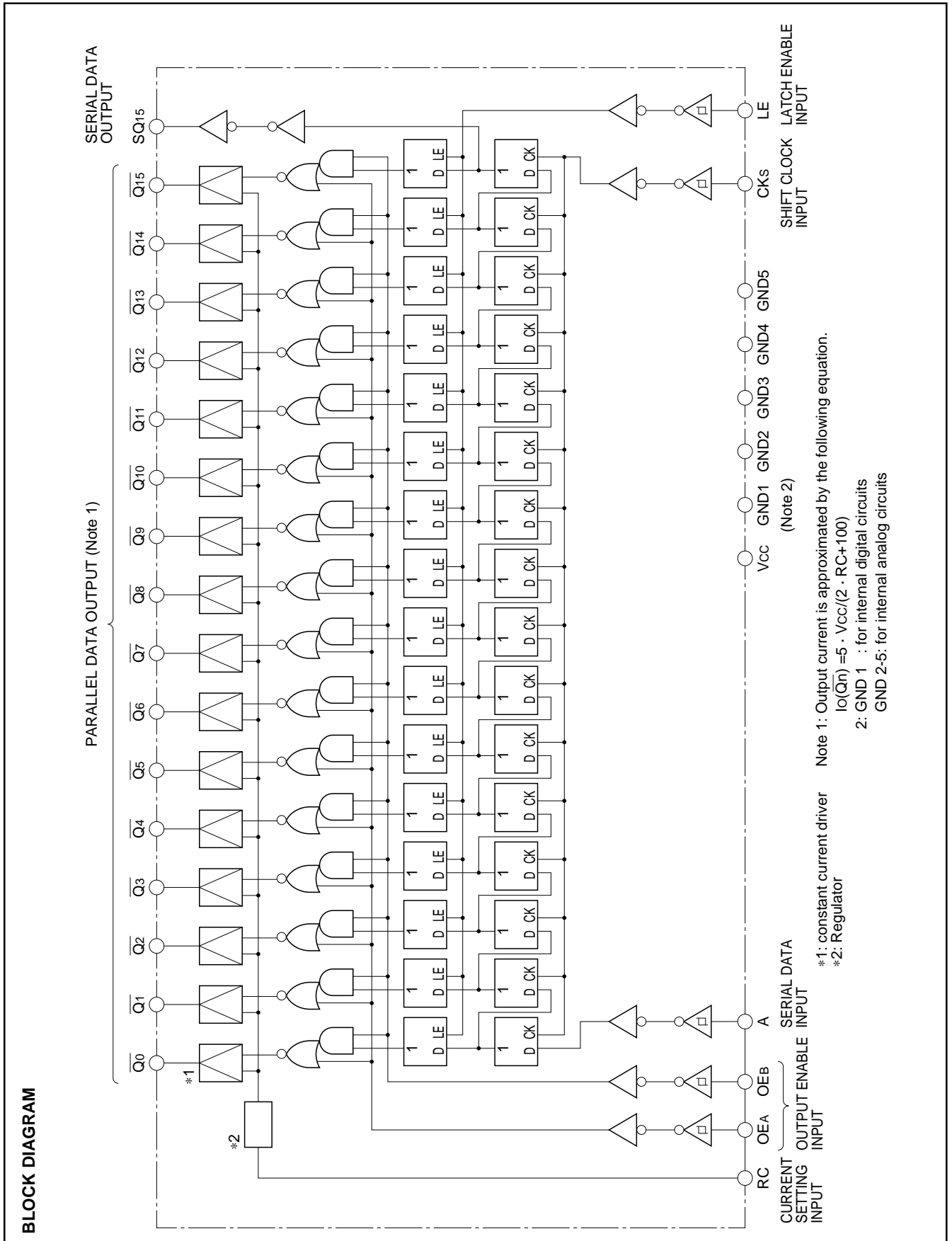

16-BIT CONSTANT CURRENT LED DRIVER with SHIFT REGISTER AND LATCH

FUNCTION TABLE (Note 3)

Input					Parallel output										Serial output		
CKs	LE	A	OEA	OEB	Q ₀	Q ₁	Q ₂	Q ₃	Q ₄	Q ₅	Q ₁₂	Q ₁₃	Q ₁₄	Q ₁₅	SQ15	
↑	H	H	L	H	L	Q ₀ ⁰	Q ₁ ⁰	Q ₂ ⁰	Q ₃ ⁰	Q ₄ ⁰	Q ₅ ⁰	Q ₁₂ ⁰	Q ₁₃ ⁰	Q ₁₄ ⁰	Q ₁₅ ⁰	q14 ⁰
↑	H	L	L	H	Z	Q ₀ ⁰	Q ₁ ⁰	Q ₂ ⁰	Q ₃ ⁰	Q ₄ ⁰	Q ₅ ⁰	Q ₁₂ ⁰	Q ₁₃ ⁰	Q ₁₄ ⁰	Q ₁₅ ⁰	q14 ⁰
X	L	X	L	H	Q ₀ ⁰	Q ₁ ⁰	Q ₂ ⁰	Q ₃ ⁰	Q ₄ ⁰	Q ₅ ⁰	Q ₁₂ ⁰	Q ₁₃ ⁰	Q ₁₄ ⁰	Q ₁₅ ⁰	q15	
X	X	L	L	L	Z	Z	Z	Z	Z	Z	Z	Z	Z	Z	q15	
X	X	H	H	X	L	L	L	L	L	L	L	L	L	L	q15	

Note 3: ↑ : Denotes change from "L" to "H".
 Q₀⁰ : Denotes state of Q output before change in CKs input.
 x : Either "L" or "H"
 q⁰ : Contents of shift register before change in CKs input
 q : Contents of shift register
 z : Denotes high impedance state

PIN DESCRIPTION

Pin	Name	Input/Output	Description
A	Serial data input pin	Input	Shift register's serial data input pin.
CKs	Shift clock input pin	Input	Clock input pin. Shifts data at leading edge.
LE	Latch enable input pin	Input	If "H", contents in shift register appear at output Q _n , and if "L", contents in shift register are latched.
OEA OEB	Output enable input pins	Input	Output enable input pins. If OEA = "H", all outputs, Q _n , are turned on. If OEA = "L" and OEB = "L", all outputs, Q _n , are turned off.
SQ15	Serial data output pin	Output	Serial data output pin of shift register
RC	Current setting input pin	Input	Connect a resistor between the RC pin and GND to set the driving current.
Q _n	LED connection pins.	Output	Driver output pins. Connect LED's cathodes to these pins.
VCC	Power supply pin		Connect to positive power source (+5V).
GND1	GND pin 1		GND for internal digital circuits.
GND2~5	GND pins 2-5		GND for internal analog circuits.

OPERATION

1. LED Drive Current Settings

The M66503A has an internal power supply, which provides a constant current to each bit output. The output value of the constant current is set by means of a load resistor, RC, connected between the RC pin and GND and is approximated by the equation below.

$$I_o(\overline{Q_n}) = 5 \cdot V_{CC} / (2 \cdot RC + 100)$$

2. Switching Operation

If the output data of the latch is "H", LED lights up. The value of the LED drive current is $I_o(\overline{Q_n})$. If the output data of the latch is "L", LED goes off, and the LED drive current becomes nearly zero, irrespective of the value of $I_o(\overline{Q_n})$.

3. How to Use the OEA and OEB Inputs

If OEA = "L" and OEB = "L", all output currents are turned off. Accordingly, it is possible to prevent a large current from flowing through LEDs by, for example, fixing both OEA and OEB to "L" until VCC, after turned on, reaches a steady state. If OEA = "H", all output currents turn on. This function facilitates the checking of LEDs for failure. When OEA = "L" and OEB = "H", each output current turns on and off according to the output data of the latch.

4. VCC and GND Pins

Pins related to the power supply function are VCC and GNDs 1-5 (GNDs 1-3 for the M66503AGP). The role of these pins in terms of the internal circuits are as follows.

VCC : commonly used by both digital and analog circuits

GND 1 : used by digital circuits

GNDs 2-5 (2-3) : used by analog circuits

In practical wiring, the following should be noted.

- (1) Secure as much width as possible for conductors and avoid lengthy wiring.
- (2) Allocate electrolytic capacitors for stable voltage near VCC and GNDs 2-5 (2-3).
- (3) Allocate by-pass capacitor near VCC and GND1.

16-BIT CONSTANT CURRENT LED DRIVER with SHIFT REGISTER AND LATCH

ABSOLUTE MAXIMUM RATINGS (Ta = -20 ~ 85°C unless otherwise noted)

Symbol	Parameter		Conditions	Ratings	Unit
V _{CC}	Supply voltage			-0.3 ~ +7.0	V
V _I	Input voltage			-0.3 ~ V _{CC} + 0.3	V
V _O	Output voltage			-0.3 ~ + 15.0	V
I _O	Output current	$\overline{Q0}\text{--}\overline{Q15}$		30	mA
		SQ15		±10	
P _d	Power dissipation	M66503ASP	Measured being mounted Ta=25°C(Note 4)	1.74	W
		M66503AGP	Measured being mounted Ta=25°C(Note 5)	1.70	
T _{stg}	Storage temperature			-65 ~ 150	°C

Note 4. When Ta ≥ 25°C, derate by 13.9mW/°C

Note 5. When Ta ≥ 25°C, derate by 13.6mW/°C

RECOMMENDED OPERATIONAL CONDITIONS

Symbol	Parameter	Conditions	Limits			Unit
			Min.	Typ.	Max.	
V _{CC}	Supply voltage		4.5	5	5.5	V
V _I	Input voltage		0		V _{CC}	V
V _O	Output voltage		0		V _{CC}	V
I _O	Output current	$\overline{Q0}\text{--}\overline{Q15}$			30	mA
T _{opr}	Operational ambient temperature	I _O (\overline{Qn})=30mA, V _O (\overline{Qn})=0.8V	-20		85	°C

ELECTRICAL CHARACTERISTICS (V_{CC} = 5V ± 10% and Ta = -20 ~ 85°C, unless otherwise noted)

Symbol	Parameter		Test conditions	Limits			Unit
				Min.	Typ.	Max.	
V _{T+}	Positive-going threshold voltage		V _O =0.1V, V _{CC} -0.1V I _O =20μA	0.35×V _{CC}		0.7×V _{CC}	V
V _{T-}	Negative-going threshold voltage		V _O =0.1V, V _{CC} -0.1V I _O =20μA	0.2×V _{CC}		0.55×V _{CC}	V
V _{OH}	"H" Output voltage	SQ15	V _{CC} =5.0V, I _{OH} =-0.4mA	4.0			V
V _{OL}	"L" Output voltage	SQ15	V _{CC} =5.0V, I _{OL} =1.6mA			0.5	V
I _{OZ}	OFF-state output current		V _O (\overline{Qn})=V _{CC}			10	μA
I _{IH}	"H" Input current		V _{CC} =5.5V, V _I =V _{CC}			5	μA
I _{IL}	"L" Input current		V _{CC} =5.5V, V _I =GND			-5	μA
I _O	Output current		V _O (\overline{Qn})=0.8V			30	mA
ΔI _O	Output current bit-to-bit error		V _{CC} =5.0V, V _O (\overline{Qn})=1.0V I _{ref} =-6mA		±3.5	±6.0	%
I _{CC}	Supply current	All outputs OFF	V _{CC} =5.5V	I _{ref} =0mA		5	mA
		All outputs ON		I _{ref} =-6mA		23	
				I _{ref} =-6mA		30	

16-BIT CONSTANT CURRENT LED DRIVER with SHIFT REGISTER AND LATCH

TIMING CONDITIONS ($V_{CC}=5V \pm 10\%$, $T_a=-20 \sim 85^\circ C$)

Symbol	Parameter	Test conditions	Limits			Unit
			Min.	Typ.	Max.	
t_w	CKs, LE pulse width	(Note 6)	30			ns
$t_{su(A)}$	Address setup time to CKs		20			ns
$t_{su(LE)}$	LE setup time to CKs		40			ns
$t_{h(A)}$	Address hold time to CKs		10			ns
t_r, t_f	CKs rise and fall time				2	μs

SWITCHING CHARACTERISTICS ($V_{CC}=5V \pm 10\%$, $T_a=-20 \sim 85^\circ C$)

Symbol	Parameter		Test conditions	Limits			Unit
				Min.	Typ.	Max.	
f_{max}	Maximum frequency for repetitions		$C_L=50pF$ $R_L=100\Omega$ (Note 6)	5			MHz
t_{PLZ}	"L-H" and "Z-L" outputs propagation time	CKs- $\overline{Q}0\sim 15$ (off)				250	ns
t_{PZL}		CKs- $\overline{Q}0\sim 15$ (on)				250	ns
t_{PLH}	"L-H" and "H-L" outputs propagation time	CKs-SQ15				250	ns
t_{PHL}							250
t_{PLZ}	"L-Z" and "Z-L" outputs propagation time	LE- $\overline{Q}0\sim 15$ (off)				250	ns
t_{PZL}		LE- $\overline{Q}0\sim 15$ (on)				250	ns
t_{PLZ}	"L-Z" and "Z-L" outputs propagation time	OEA- $\overline{Q}0\sim 15$ (off)				250	ns
t_{PZL}		OEA- $\overline{Q}0\sim 15$ (on)				250	ns
t_{PLZ}	"L-Z" and "Z-L" outputs propagation time	OEB- $\overline{Q}0\sim 15$ (off)				250	ns
t_{PZL}		OEB- $\overline{Q}0\sim 15$ (on)				250	ns

NOTE 6: TEST CIRCUIT

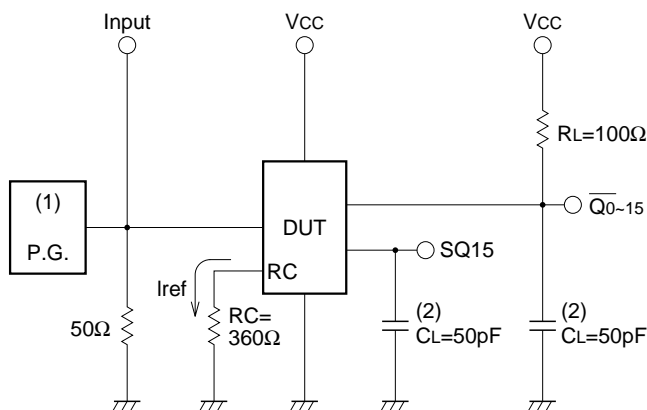

(1) Characteristics of pulse generator (PG)

Rise time : $t_r = 6ns$

Fall time : $t_f = 6ns$

Output impedance : $Z_o = 50\Omega$

(2) Capacitance C_L includes the stray capacitance of the lead wires and the probe input capacitance.

16-BIT CONSTANT CURRENT LED DRIVER with SHIFT REGISTER AND LATCH

TIMING CHARTS

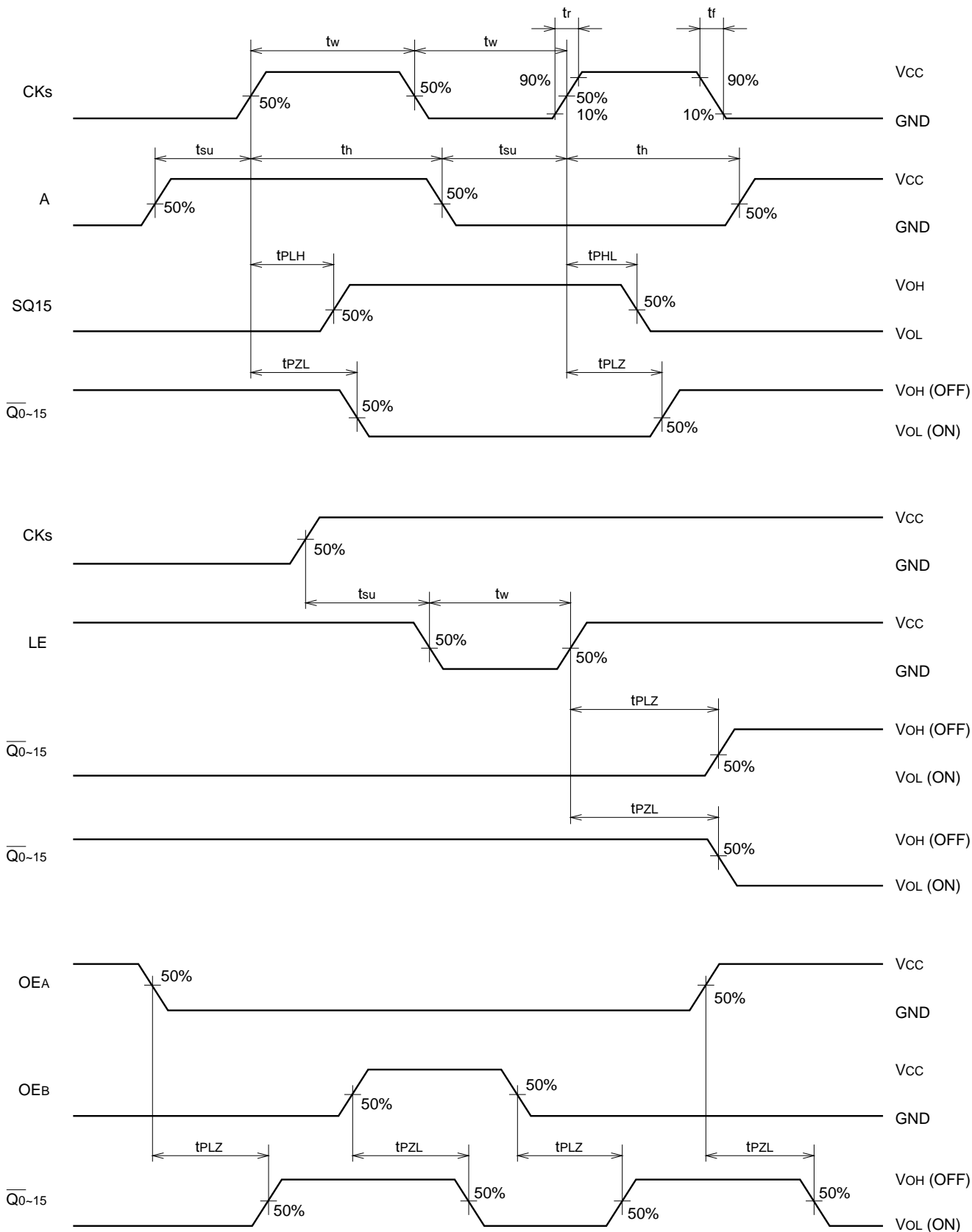

16-BIT CONSTANT CURRENT LED DRIVER with SHIFT REGISTER AND LATCH

TYPICAL CHARACTERISTICS

OUTPUT CURRENT VS REFERENCE CURRENT CHARACTERISTICS (Q₀ ON)

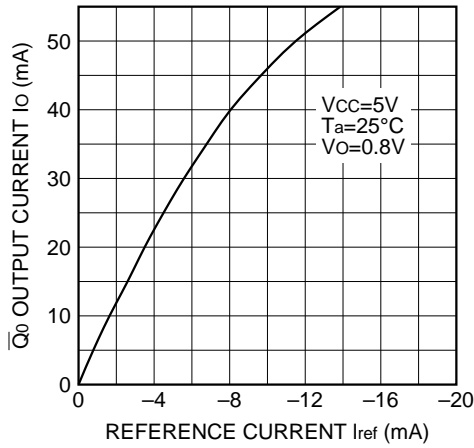

OUTPUT CURRENT VS OUTPUT VOLTAGE CHARACTERISTICS

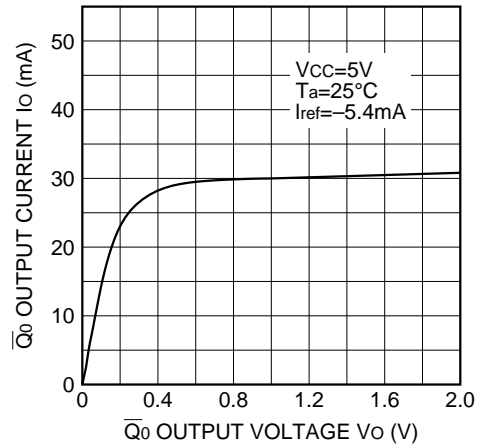

APPLICATION EXAMPLE

