

TYPE
NAME

ML701B8R,ML725B8F,ML725C8F
ML720J8S,ML720K8S

DESCRIPTION

ML7XX8 series are InGaAsP laser diodes which provides a stable, single transverse mode oscillation with emission wavelength of 1310nm and standard continuous light output of 10mW.

ML7XX8 are hermetically sealed devices having the photodiode for optical output monitoring. This high-performance, high reliability, and long-life laser diode is suitable for such applications as the light sources for long-distance optical communication systems.

FEATURES

- 1310nm typical emission wavelength
- Low threshold current, low operating current
- High-power, wide temp. range operation
($P_o=10mW, T_c=-40\sim+85^{\circ}C$)
- High reliability, long operation life
- Have a lens-cap
(ML725C8F,ML720K8S)
- MQW* active layer
* : Multiple Quantum Well

APPLICATION

Optical communication system

ABSOLUTE MAXIMUM RATINGS

Symbol	Parameter	Conditions	Ratings (Note1)	Unit
P _O	Light output power	—	10 [7]	mW
V _{RL}	Reverse Voltage (Laser diode)	—	2	V
V _{RD}	Reverse Voltage (Photodiode)	—	20	V
I _{FD}	Forward current (Photodiode)	—	2	mA
T _c	Case temperature	—	-40~+85	°C
T _{stg}	Storage temperature	—	-40~+100	°C

ELECTRICAL/OPTICAL CHARACTERISTICS (T_c = 25°C)

Symbol	Parameter	Test conditions	Limits (Note1)			Unit
			Min.	Typ.	Max.	
I _{th}	Threshold current	CW	—	5	15	mA
I _{OP}	Operating current	CW,P _O = 5mW	—	20	35	mA
V _{OP}	Operating voltage	CW,P _O = 5mW	—	1.1	1.5	V
η	Slope efficiency	CW,P _O = 5mW	0.3 [0.2]	0.5 [0.35]	—	mW/mA
λ _c	Center wavelength	CW,P _O = 5mW	1290	1310	1330	nm
Δλ	Spectral width (RMS)	CW,P _O = 5mW	—	1	2	nm
θ _∥	Beam divergence angle (parallel)	CW,P _O = 5mW	—	25 [11]	—	deg.
θ _⊥	Beam divergence angle (perpendicular)	CW,P _O = 5mW	—	30 [11]	—	deg.
t _r ,t _f	Rise and fall times	I _F = I _{th} ,P _O = 5mW,10~90%	—	0.3	0.7	ns
I _m	Monitoring output current (Photodiode)	CW,P _O = 5mW,V _{RD} = 1V	0.1	0.5	—	mA
I _D	Dark current (Photodiode)	V _{RD} = 10V	—	0.01	0.1	μA
C _t	Capacitance (Photodiode)	V _{RD} = 10V,f = 1MHz	—	10	20	pF
P _f (Note 2)	Fiber coupled power	CW,P _O = 5mW,S110/125	[0.4]	[0.8]	[—]	mW
D _f (Note 3)	Fiber coupled distance	CW,P _O = 5mW,S110/125 (Note 3)	[5.0]	[5.8]	[6.2]	mm

Note 1 : Limits in [] applied to the lens-cap type.

Note 2 : P_f,D_f are applied to the lens-cap type.

Note 3 : D_f is a distance from the reference plane to the fiber.

MITSUBISHI LASER DIODES
ML7XX8 SERIES

InGaAsP — MQW — FP LASER DIODES

TYPICAL CHARACTERISTICS

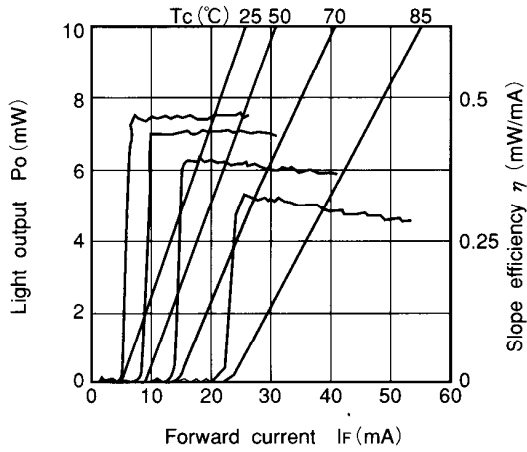

Fig.1 Light output vs. forward current

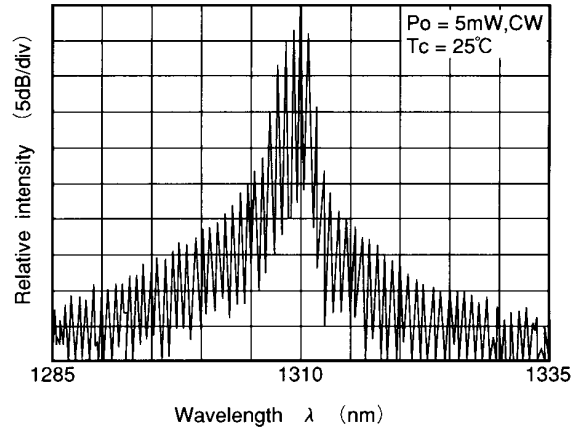

Fig.52 Spectrum

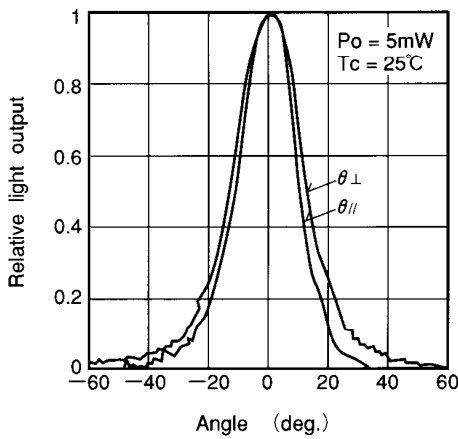

Fig.3 Far field pattern

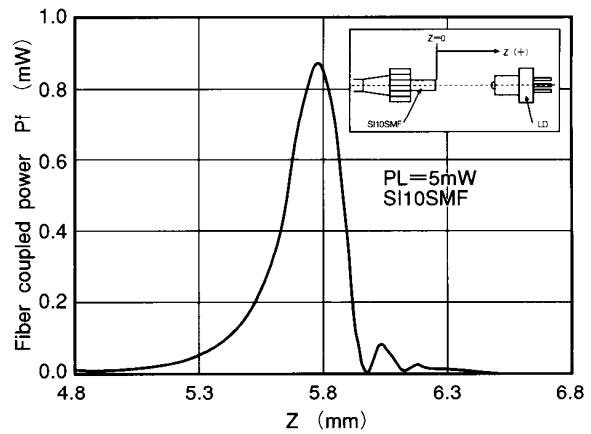
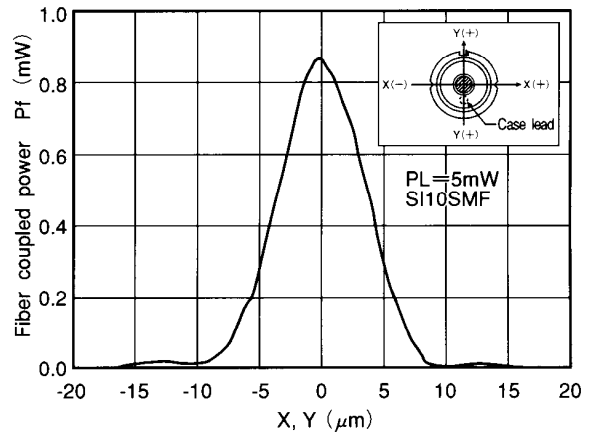

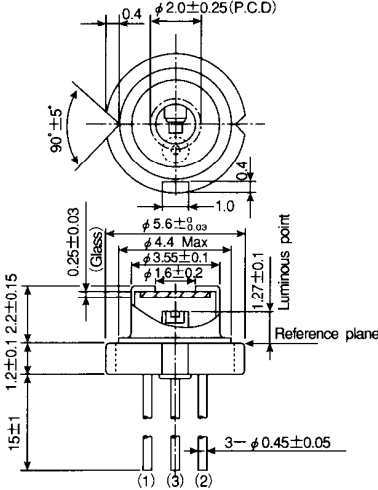
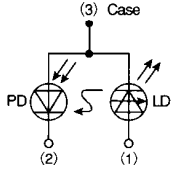
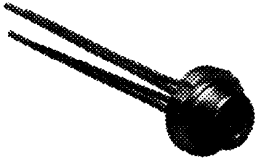
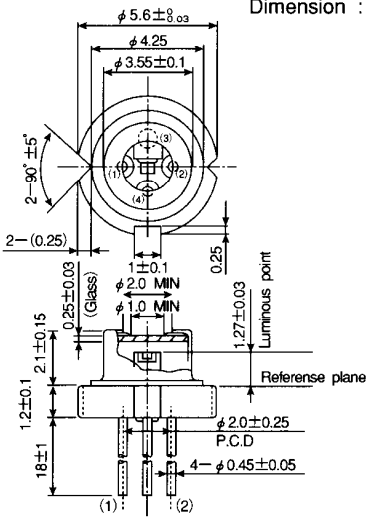
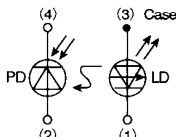
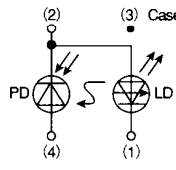

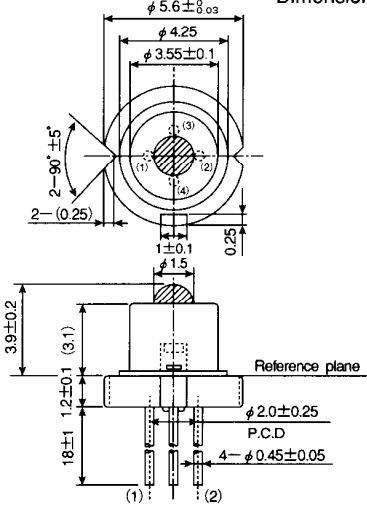
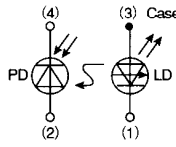
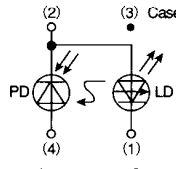

Fig.4 Fiber coupling characteristics
(ML725C8F, ML720K8S)

MITSUBISHI LASER DIODES
ML7XX8 SERIES

InGaAsP — MQW — FP LASER DIODES

OUTLINE DRAWINGS

<p>ML701B8R</p> 	<p>Dimension : mm</p> 	
<p>ML725B8F ML720J8S</p> 	<p>Dimension : mm</p> 	 <p>ML725B8F</p>  <p>ML720J8S</p>
<p>ML725C8F ML720K8S</p> 	<p>Dimension : mm</p> 	 <p>ML725C8F</p>  <p>ML720K8S</p>