

Step-Up DC/DC Converter (PWM) Monolithic IC MM1349

Outline

This is a converter IC which steps up the DC input voltage to output a fixed voltage level. Utilizing technology for low-voltage operation, which is a feature of Mitsumi semiconductor processes, operation is possible beginning at 0.90V, making this device ideal for the power supply circuits of portable equipment driven by a single battery.

Because PWM oscillation is adopted, an output waveform can be obtained with a smaller peak-to-peak voltage than is possible for VFM devices.

Features

1. Low-voltage operation possible, 0.90V (no-load)
2. Internal oscillation circuit
3. Adoption of PWM oscillation for output waveform with small peak-to-peak voltage
4. Numerous output voltages available (seven ranks)

Package

SOT-25

Output Voltage Rank

Rank	A	B	C	D	E	G	H
Voltage (V)	5.0	3.5	3.2	3.0	2.7	2.5	2.2

Applications

1. Pagers
2. Separate vibrators
3. Other portable equipment

Pin Assignment

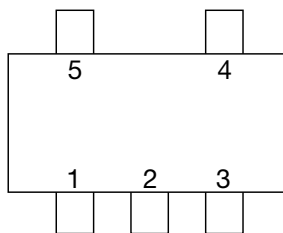

SOT-25

1	GND
2	SUB
3	V _L
4	V _{OUT}
5	V _{IN}

*Pin 2 is the SUB pin, and should be connected to GND.

Block Diagram

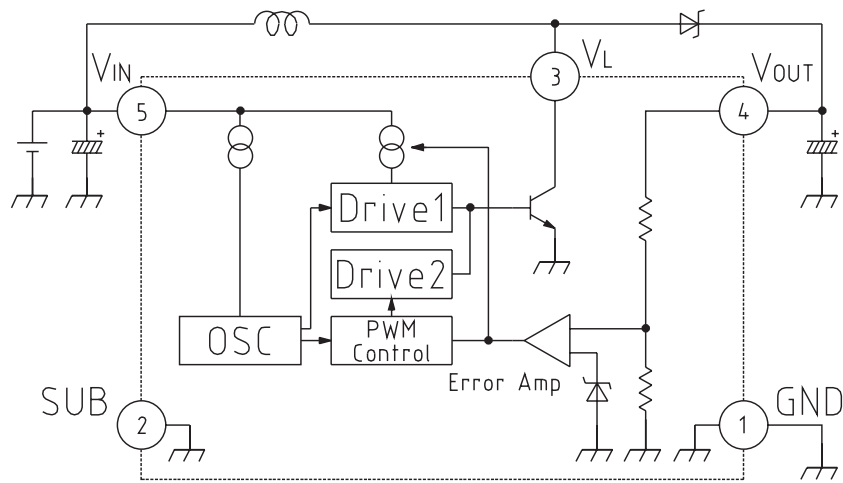

Note: Pin 2 is the SUB pin, and should be connected to GND.

Absolute Maximum Ratings (Ta=25°C)

Item	Symbol	Ratings	Units
Storage temperature	T _{STG}	-40~+125	°C
Operating temperature	T _{OPR}	-20~+75	°C
Voltage applied to V _{IN} pin		-0.3~+10.0	V
Voltage applied to V _{OUT} pin		-0.3~+10.0	V
Voltage applied to V _L pin		-0.3~+10.0	V
Allowable loss	P _d	150	mW

Recommended Operating Conditions

Item	Symbol	Ratings	Units
Operating temperature	T _{op}	-20~+75	°C
Operating voltage	V _{op}	+0.9~V _{OUT}	V

Electrical Characteristics (Ta=25°C)(Except where noted otherwise, VIN=1.5V, Io=1mA)

Item	Symbol	Measurement conditions	Min.	Typ.	Max.	Units	
Operating voltage	VIN	No-load	0.90		VOUT	V	
Output voltage	VOUT	VIN=1.5V, Io=1mA	A	4.80	5.00	5.20	V
			B	3.36	3.50	3.64	
			C	3.07	3.20	3.33	
			D	2.88	3.00	3.12	
			E	2.59	2.70	2.81	
			F	2.40	2.50	2.60	
			G	2.11	2.20	2.29	
Output voltage temperature coefficient		Ta=-20~75°C		±100		ppm/°C	
Input fluctuations		VIN=1.1→1.7V, Io=1mA			1	%/V	
Load fluctuation		VIN=1.5V, Io=0→4mA			1	%/mA	
Efficiency		VIN=1.5V, Io=1mA		80		μA	
VL pin leakage current	IVLLK	VL=10V			1	μA	
Oscillation frequency	fOSC	VIN=1.5V, Io=1mA	35	65	95	kHz	

Note: These characteristics assume the following externally mounted components.

Coil: L=120μH (Mitsumi model C5-R)

Capacitor: C=33μF (tantalum electrolytic capacitor)

Schottky barrier diode (Rohm model RB451F)

Measuring Circuit

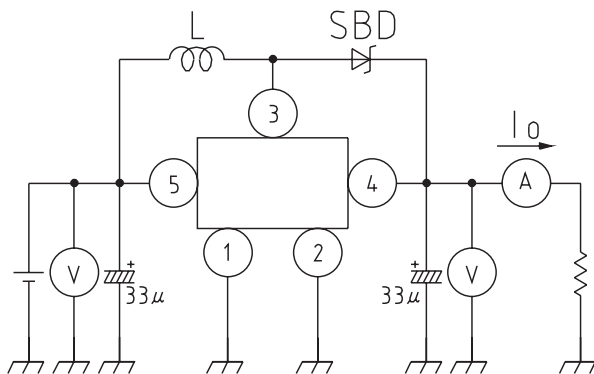

Note 1: A: DC ammeter
V: DC voltmeter

Note 2: L=120μH

Application Circuits

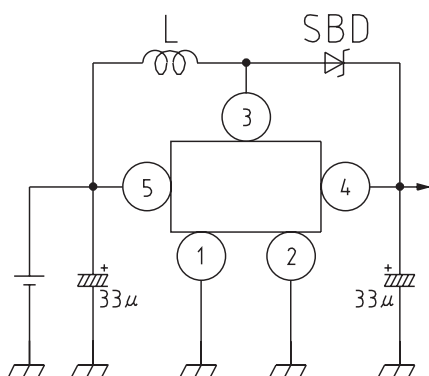

Coil: L=120μH (Mitsumi model C5-R)

Capacitor: C=33μF (tantalum electrolytic capacitor)

Schottky barrier diode (Rohm model RB451F)