

# Remaining Battery Power Display Monolithic IC MM1206

## Outline

This IC detects battery voltage and displays the remaining power on an LED or LCD display. The appeal of battery-driven equipment lies in its portability, but when the battery runs down and the equipment does not function, customer complaints and breakdowns may result.

This IC prevents such trouble before it starts.

## Features

1. There are three displays for remaining battery power :  
FULL / MIDDLE / EMPTY.
2. Nine patterns built in for detection voltage, linked to two manganese batteries.  
Standard setting : 2.5V, 2.25V
3. External parts held to a minimum

## Package

SOP-8D (MM1206XF)  
VSOP-8A (MM1206AF)

## Detection Voltage Matrix Chart

SW1	SW2	Detection Voltage 1	Detection Voltage 2
GND	GND	2.64V	2.35V
GND	OPEN	2.62V	2.27V
GND	V <sub>cc</sub>	2.60V	2.18V
OPEN	GND	2.52V	2.35V
OPEN	OPEN	2.50V	2.25V
OPEN	V <sub>cc</sub>	2.48V	2.17V
V <sub>cc</sub>	GND	2.42V	2.30V
V <sub>cc</sub>	OPEN	2.40V	2.24V
V <sub>cc</sub>	V <sub>cc</sub>	2.38V	2.15V

\*Voltage Accuracy  
Detection Voltage 1 : ±100mV typ.  
Detection Voltage 2 : ±90mV typ.

## Absolute Maximum Ratings (Ta=25°C)

Item	Rating
Storage temperature	-40~+125°C
Operating temperature	-20~+70°C
Input voltage	5V
Allowable loss	300mW

**Electrical Characteristics** (Unless otherwise specified Ta=25°C, SW1=SW2=open)

Item	Symbol	Measurement Conditions	Min.	Typ.	Max.	Unit.
Current consumption I	I <sub>CC</sub>	V <sub>CC</sub> =3.0V		0.75	1.1	mA
Detection voltage I	V <sub>TH1</sub>	V <sub>CC</sub> =H→L	2.4	2.5	2.6	V
Detection voltage II	V <sub>TH2</sub>	V <sub>CC</sub> =H→L	2.16	2.25	2.34	V
Detection voltage difference	ΔV <sub>T</sub>	ΔV <sub>T</sub> =V <sub>TH1</sub> -V <sub>TH2</sub>	210	250	290	mV
Detection voltage temperature factor	V <sub>TH</sub> /ΔT			±200		ppm/°C
Detection voltage I, Adjustment 1	+ΔV <sub>T1</sub>	SW1=GND	70	100	130	mV
Detection voltage I, Adjustment 2	-ΔV <sub>T1</sub>	SW1=V <sub>CC</sub>	-70	-100	-130	mV
Detection voltage II, Adjustment 1	+ΔV <sub>T2</sub>	SW2=GND	70	100	130	mV
Detection voltage II, Adjustment 2	-ΔV <sub>T2</sub>	SW2=V <sub>CC</sub>	-70	-100	-130	mV
Output sink current I	I <sub>S1</sub>	V <sub>CC</sub> =2.7V, V <sub>CE</sub> =0.5V	5	10		mA
Output sink current II	I <sub>S2</sub>	V <sub>CC</sub> =2.38V, V <sub>CE</sub> =0.5V	5	10		mA
Output sink current III	I <sub>S3</sub>	V <sub>CC</sub> =2.0V, V <sub>CE</sub> =0.5V	5	10		mA
Output saturation voltage I	V <sub>CE1</sub>	V <sub>CC</sub> =2.7V, I <sub>SINK</sub> =1mA		100	150	mV
Output saturation voltage II	V <sub>CE2</sub>	V <sub>CC</sub> =2.38V, I <sub>SINK</sub> =1mA		100	150	mV
Output saturation voltage III	V <sub>CE3</sub>	V <sub>CC</sub> =2.0V, I <sub>SINK</sub> =1mA		50	80	mV
Output leak voltage I	I <sub>LE1</sub>	V <sub>CC</sub> =2.3V, V <sub>CE</sub> =1.5V			1	μA
Output leak voltage II	I <sub>LE2</sub>	V <sub>CC</sub> =2.7V, V <sub>CE</sub> =1.5V			1	μA
Output leak voltage II	I <sub>LE2'</sub>	V <sub>CC</sub> =2.0V, V <sub>CE</sub> =1.5V			1	μA
Output leak voltage III	I <sub>LE3</sub>	V <sub>CC</sub> =2.5V, V <sub>CE</sub> =1.5V			1	μA

**Block Diagram, Example of Application Circuit**

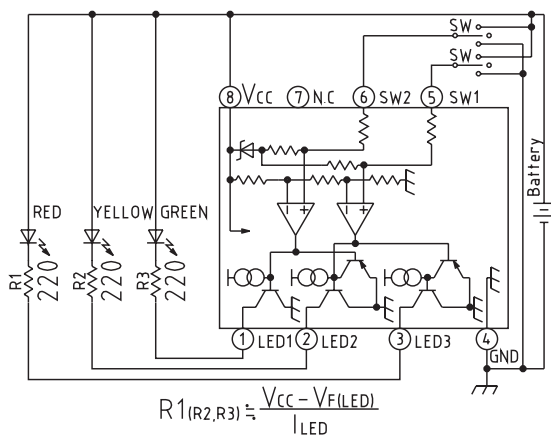

	2.50V	2.25V	
LED1	ON	OFF	OFF
LED2	OFF	ON	OFF
LED3	OFF	OFF	ON

**Timing Chart**

