

# Remaining Battery Power Display Monolithic IC MM1305

## Outline

This IC detects battery voltage and displays the power remaining in the battery. Portable equipment is becoming more and more popular, and one standard function of this type of equipment is remaining battery power display. This IC has four threshold voltages built in. Since their respective detection circuits share the reference voltage on one chip, the detection voltage for each lags in the same direction. Thus, there is much smaller error as compared to the reciprocal error resulting from combining single circuits.

Also, the stepped display of remaining battery power as in nickel cadmium, nickel hydrogen and lithium ion batteries is enabled through super high precision voltage detection of  $\pm 1\%$ .

## Features

1. A separate line-up of detection voltages for alkaline magnesium and nickel cadmium and nickel hydrogen batteries.

Alkaline magnesium : 1.350V /1.285V /1.200V /1.100V

Nickel cadmium, nickel hydrogen : 1.275V /1.245V /1.205V /1.100V

2. Super high precision detection voltage :  $\pm 1\%$  typ.

3. Low current consumption : Waiting : 1.5 $\mu$ A

Detection : 12 $\mu$ A

4. Ripple absorption pin

Enables continuous ripple absorption and suppresses detection errors.

5. Built-in hysteresis voltage

## Package

VSOP-8A (MM1305XW, MM1305AW, MM1305BW)

## Absolute Maximum Ratings

Item	Specification	Unit
Storage temperature	-40~+125	°C
Operating temperature	-20~+70	°C
Input voltage	5	V
Output pin voltage	5	V
Allowable loss	300	mW

**Electrical Characteristics** (Unless otherwise specified Ta=25°C, Vcc=1.5V)

Item		Measurement Conditions	Min.	Typ.	Max.	Unit
Current consumption				12.0	8.0	μA
Current consumption during waiting		Vcc=1.3V, CE pin=L		1.5	2.5	μA
Detection voltage 1	Rank A	Vcc=H→L	1.330	1.350	1.370	V
2			1.270	1.285	1.300	
3			1.185	1.200	1.215	
4			1.089	1.100	1.111	
1	Rank X	Vcc=H→L	1.262	1.275	1.288	V
2			1.232	1.245	1.258	
3			1.193	1.205	1.217	
4			1.089	1.100	1.111	
Detection voltage Difference 1	Rank A	$\angle V_{TH1}=V_{TH1}-V_{TH4}$	230	250	270	mV
2		$\angle V_{TH2}=V_{TH2}-V_{TH4}$	160	185	200	
3		$\angle V_{TH3}=V_{TH3}-V_{TH4}$	85	100	115	
1	Rank X	$\angle V_{TH1}=V_{TH1}-V_{TH2}$	20	30	40	mV
2		$\angle V_{TH2}=V_{TH2}-V_{TH3}$	30	40	50	
3		$\angle V_{TH3}=V_{TH2}-V_{TH4}$	135	145	155	
Detection voltage temperature factor				±200		ppm/°C
Hysteresis voltage			10	20	35	mV
Output sink current		Vcc=1.3V, Output saturation voltage=0.3V	40			μA
Output saturation voltage 1		Isink=30μA		150	250	mV
2			150	250		
3			150	250		
4			150	250		
Output leak voltage 1		Vcc=1.0V, Output saturation voltage=1.5V			1	μA
2					1	
3					1	
4					1	
Power supply voltage operating limit				0.70	0.75	V
CEpin	Input H voltage	CE pin=0V	Vcc-0.3	Vcc	Vcc-0.3	V
	L voltage		100	300	500	nA
	L voltage		-0.3	0	-0.3	V
Ripple absorption resistance		measure resistance between pins 8pin-6pin	70	100	130	kΩ

Block Diagram, Example of Application Circuit

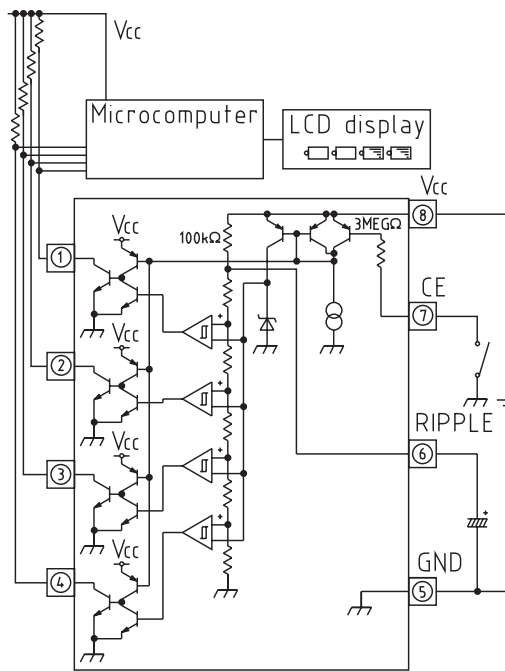

Timing Chart

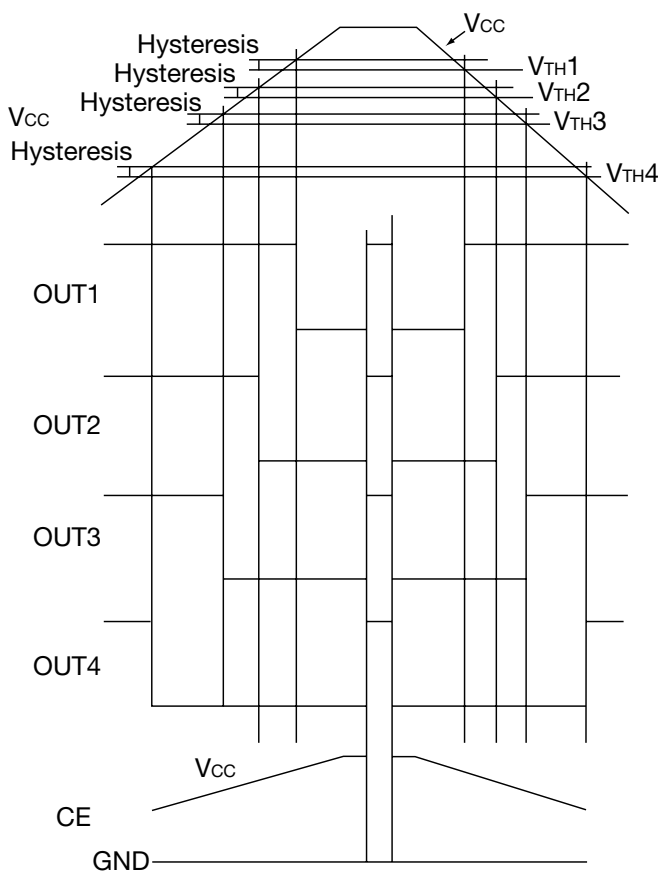

Output

Vcc	VTH1	TH2	TH3	TH4
OUT 1	L	H	H	H
OUT 2	L	L	H	H
OUT 3	L	L	L	H
OUT 4	L	L	L	L

CE pin

H	Operation
L	Waiting

Note : Please connect the CE pin to Vcc when not using.