

Control of Lithium Ion Battery Charging and Discharging Monolithic IC MM1214

Outline

This IC controls constant current charging and excess discharge for lithium-ion batteries (sub-batteries). It performs constant current charging, stops charging at set voltages, and prevents excess discharging. When the voltage falls below a set level, it prohibits discharges and reduces IC current consumption nearly to zero.

Features

During charging

1. Input voltage range		4.5V~15.0V
2. Current consumption (VIN pin)	$V_{BATT}<4.1V$	9mA typ.
3. Current consumption (VCC pin)	$I_{BATC}=0mA$	500 μ A typ.
4. Charging current switching voltage		2.7V \pm 0.1V
5. Charging current (normal conditions)		105mA typ.
6. Charging current (low voltages)		5.0mA typ.
7. Charging control voltage (Ta =-20~+70°C)		4.200V \pm 0.063V
8. Overvoltage detection voltage (Ta =-20~+70°C)		4.335V \pm 0.065V
9. Overvoltage reset voltage		3.50V \pm 0.13V
10.Overvoltage detection non-induction time	$C_{CC}=2.22\mu F$	0.80S typ.
11.Overvoltage reset non-induction time	$C_{CC}=0.22\mu F$	0.80S typ.

During discharging

12.Current consumption (Vbat pin)	$I_L=10mA$	450 μ A typ.
13.Current consumption (Vbat pin)	$I_L=0mA$	15 μ A typ.
14.Current consumption (Vbat pin) discharging off,	$: V_{BAT}<2.4V$	0.1 μ A max.
15.Excess discharging detection voltage		2.30V \pm 0.19V
16.Discharge resumption voltage		2.70V \pm 0.1V
17.Voltage drop between battery and output ($V_{BATT}=3.0V, I_L=-10mA$)		70mV typ.
18.Voltage drop between battery and output ($I_L=100\mu A, V_{BATT}=3V$)		2.92V typ.

Package

SSOP-16A (MM1214XF)

Application

For overnight charging

Pin Assignment

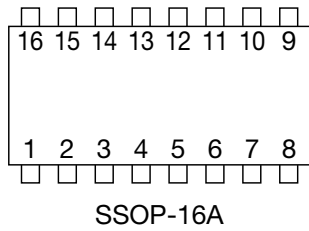

1	GND	9	Vo2
2	N.C	10	Vo1
3	TCH	11	V _{BAT}
4	CD	12	N.C
5	N.C	13	V _{IN}
6	N.C	14	N.C
7	N.C	15	V _{CC}
8	V _{OV}	16	N.C

Block Diagram

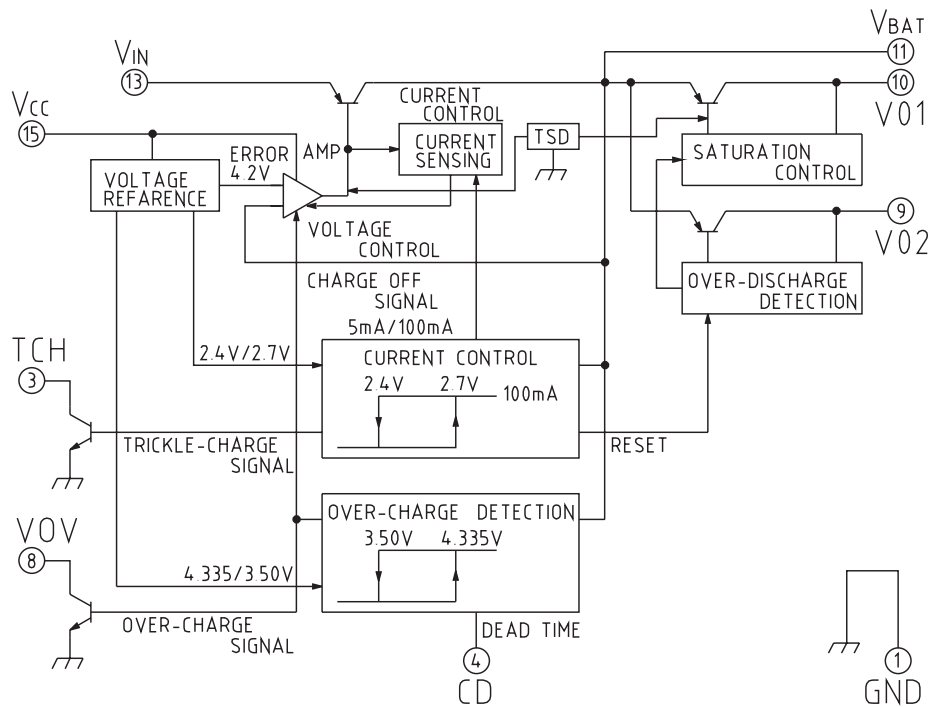

Absolute Maximum Ratings

Item	Symbol	Rating	Units
Storage temperature	T _{STG}	-40~+125	°C
Operating temperature	T _{OPR}	-20~+70	°C
input voltage	V _{INN} max.	18	V
Power supply voltage	V _{CC} max.	18	V
Battery voltage	V _{BAT} max.	4.4	V
VOV pin applied voltage	V _{VOV} max.	10	V
TCH pin applied voltage	V _{TCH} max.	10	V
Charging current	I _{CHG} max.	-150	mA
Output current	I _{BAT} max.	-30	mA
Allowable power dissipation 1	P _{d1}	500	mW
Allowable power dissipation 2 (Note 1)	P _{d2}	1000	mW

Note 1 : When mounted on glass epoxy board (10 × 25 × 0.8) Plated area 80% (Refer to Fig.1)

Electrical Characteristics (Unless otherwise specified Ta=25°C, V_{CC}, V_{IN}=6.5V)

Item	Symbol	Measurement Conditions	Min.	Typ.	Max.	Units
Charging input operation range 1	V _{INOPR1}	During low-current charging (Note 2)	4.50		(15.0)	V
Charging input operation range 2	V _{INOPR2}	During rapid charge	4.50		5.5	V
Power supply input operation range	V _{CCOPR}	Charging OFF	4.50		15.0	V
Current consumption (V _{IN} pin)	I _{IN}	V _{BAT} < 4.1V		9	12	mA
Current consumption (V _{CC} pin)	I _{CC}	I _{BATC} =0mA		500	750	μA
Current consumption (V _{BAT} pin) 1	I _{BAT1}	I _L =10mA, V _{CC} =0V, V _{BATT} =3V		450	550	μA
Current consumption (V _{BAT} pin) 2	I _{BAT2}	I _L =0mA, V _{CC} =0V, V _{BATT} =3V		15	30	μA
Current consumption (V _{BAT} pin) 3	I _{BAT3}	V _{BAT} < 2.4V (Discharging OFF), V _{CC} =0V			0.1	μA
Charge control voltage	V _{BATC}	Ta=-20~+70°C	4.137	4.200	4.263	V
Overcharge detection voltage	V _{BATU}	Ta=-20~+70°C	4.270	4.335	4.400	V
Overcharge reset voltage	V _{BATO}	V _{BATT} =4.5V→3.0V	3.37	3.50	3.63	V
Detection voltage margin 1	ΔV _{UC}	V _{BATU} -V _{BATC} , Ta=-20~+70°C	100	135		mV
Charge current conversion voltage	V _{CH}	V _{BATT} =2.0V→3.0V	2.60	2.70	2.80	V
Charge hysteresis voltage	ΔV _{CH}	V _{BATT} =3.0V→2.0V	300	400	500	mV
Charge current (During low voltage)	I _{TCH}	V _{BATT} < V _{CH} -ΔV _{CH}	-6.5	-5.0	-3.5	mA
Charge current (Normal)	I _{BATC1}	4.0V > V _{BAT} > V _{CH}	-115	-105	-95	mA
Charge current 1 (Normal)	I _{BAT1CT}	Ta=-20~+70°C, V _{IN} =4.5V~5.5V	-120	-105	-90	mA
Charge current 2 (Normal)	I _{BAT2CT}	Ta=-20~+70°C, V _{IN} =4.5V~6.5V	-125	-105	-90	mA
Charge with constant current mode OFF	I _{BATC2}	V _{BAT} =4.0V	-115		-80	mA
Excess discharging detection voltage	V _{BATS}	V _{BATT} =3.0V→2.0V	2.11	2.30	2.49	V
Discharge resumption voltage	V _{BATD}	V _{CC} > 4.5V	2.60	2.70	2.80	V
Voltage drop between battery and output	V _{CE}	V _{BAT} =3.0V, I _L =10mA		70	100	mV
VOV pin sink current	I _{SIVOV}	V _{BATT} =4.4V, V _{VOV} =0.4V	1.00	4.00		mA
VOV pin leak current	I _{LVOV}	V _{BAT} =4.0V			0.1	μA
VOV pin output voltage	V _{VOV}	I _{VOV} =1mA		0.25	0.35	V
TCH pin sink current	I _{SITCH}	V _{BAT} =2.0V, V _{TCH} =0.4V	1.00	4.00		mA
TCH pin leak current	I _{LTCH}	V _{BAT} =3.0V			0.1	μA
TCH pin output voltage	V _{TCH}	I _{TCH} =1mA		0.25	0.35	V
CD pin charge current	I _{CDC}	V _{CD} =1.5V, V _{BAT} =4.4V	-800	-600	-400	nA
CD pin discharge current	I _{CDDC}	V _{CD} =1.5V, V _{BAT} =3.0V	500	680	860	nA
CD pin H voltage	V _{CDH}	V _{BATT} =4.5V	2.65	2.90	3.15	V
CD pin threshold voltage 1	V _{THC1}	V _{CD} =3V→0V	0.65	0.73	0.91	V
CD pin threshold voltage 2	V _{THC2}	V _{CD} =0V→3V	2.00	2.35	2.70	V
Overvoltage detection non-induction time	t _{dCD1}	C _{CD} =0.22μF	0.40	0.80	1.60	S
Overvoltage reset non-induction time	t _{dCD2}	C _{CD} =0.22μF	0.40	0.80	1.60	S

Note 2 : During rapid charging, use 5.5 V Vin power supply.

Note 3 : V_{O2} has no current supply capacity, so do not connect load.

Characteristics

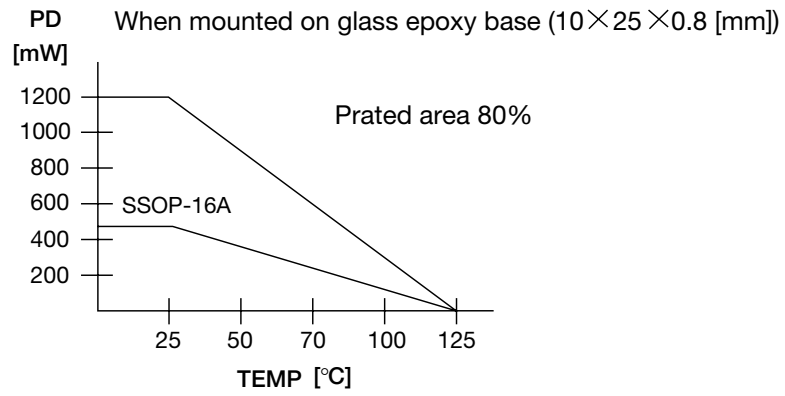

Fig.1

Application Circuits

