

High Precision Operational Amplifier Monolithic IC MM1278

Outline

This IC is a dual-type operational amplifier, with two built-in operational amplifiers, and achieves extremely low offset voltage with a single power supply. The input offset voltage and the input offset voltage temperature drift of this operation amplifier are one digit less than those of our conventional products. A single power supply can be used, so there is no need to create a mid-point potential, and it can be operated with the voltage from two batteries. Due to the single power supply, low current consumption, and low offset voltage, two batteries can be used for operation, making it appropriate for equipment that amplifies the very small signal of portable equipment.

Features

General

- | | |
|--|--|
| 1. Power supply voltage | $V_{CC}=1.8V\sim 6V$
optimum for drive by batteries |
| 2. Current consumption | 0.1mA typ. |
| 3. Power supply line elimination ratio | 60dB typ. |

Amplifier section

- | | |
|-----------------------------------|----------------------------|
| 1. Input voltage range | $-0.2V\sim +0.3V$ |
| 2. Super low input offset voltage | $\pm 0.1mV$ typ. |
| 3. Input offset voltage | $\pm 1\mu V/^\circ C$ typ. |
| 4. Input offset current | 1nA typ. |
| 5. Input bias current | 50nA typ. |
| 6. Gain | 100dB typ. |

Package

- SOP-8D (MM1278XA)
- DIP-8A (MM1278XD)

Applications

1. Amplification and detection of normal very small voltage on portable equipment.
2. Amplification of very small voltage for sensors (thermocouples, strain gauges, magnetic sensors)
3. Detedtion of very small current

Pin Assignment

MM1278XF, MM1278XD

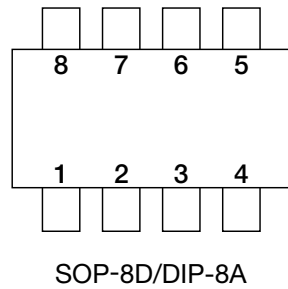

1	A _{IN+}
2	A _{IN-}
3	A _{OUT}
4	GND
5	B _{IN+}
6	B _{IN-}
7	B _{OUT}
8	V _{CC}

Block Diagram

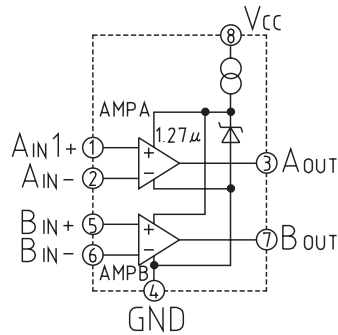

Absolute Maximum Ratings (T_a=25°C)

Item	Symbol	Rating	Units
Storage temperature	T _{STG}	-40~+125	°C
Operating temperature	T _{OPR}	-20~+75	°C
Power supply voltage	V _{CC max.}	-0.3~+10	V
Input voltage	V _{IN}	-0.3~+10	V
Allowable power dissipation	P _d	300	mW

Electrical Characteristics (Unless otherwise specified Ta=25°C, VCC=3V, VIN=0V)

Item	Symbol	Measurement Conditions	Min.	Typ.	Max.	Units
Current consumption	ICC			0.1	0.15	mA
Power supply line elimination ratio	PSRR	f=100Hz	50	60		dB
Power supply voltage range	VCC		1.8	3.0	6.0	V
Amplifier section	Input voltage range	VI	-0.2		0.3	V
	Input offset voltage	VIOA		±0.1	±0.35	mV
	Input offset voltage temperature drift	ΔVIOA		±1	±3	μV/°C
	Input offset current	IIOA		1	10	nA
	Input bias current	IBA		50	150	nA
	Gain	GV	RL=100kΩ	80	100	dB
	Output current	IOA	VIN=10mV, VO=0.5V	0.5		mA
	Output voltage	VOA	VIN=-5~-25mV RL=10kΩ	0.01		VCC -1.0

Note : Use a gain range of 20dB ~ 50dB in the amplifier section (40dB recommended).

Also, insert the capacitor between output and GND, instead of parallel to the gain setting feedback resistor, in order to eliminate noise from the input.

Please note that use of the equipment under different conditions will cause vibration.