

System Reset Monolithic IC PST92XX Series

Outline

This reset IC in an ultra-compact package provides highly accurate detection and includes a delay circuit.

Features

- | | |
|----------------------------|--|
| 1. Delay circuit | delay time can be set through an external capacitor. |
| 2. High detection accuracy | $V_s \pm 1.5\%$. |
| 3. Low consumption current | $3\mu\text{A typ.}$ |

Package

SOT-25

Applications

Microcomputer reset and detection of remaining battery charge.

Pin Assignment

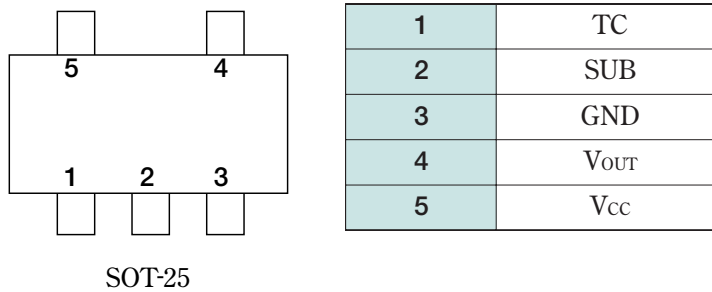

Equivalent Circuit Diagram

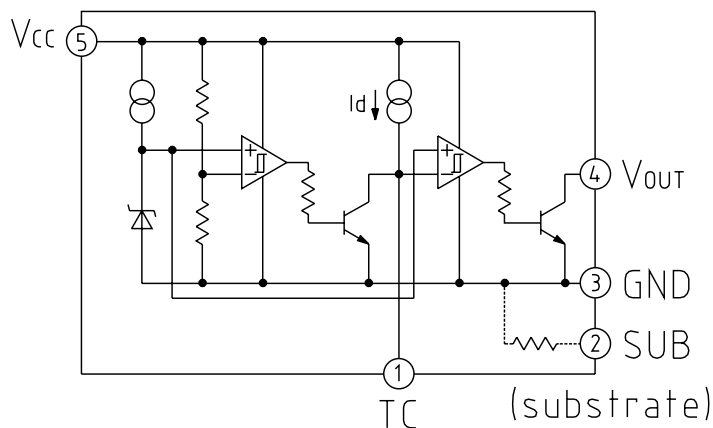

Pin Description

Pin No.	Pin name	Functions
1	TC	T _{PLH} control pin
2	SUB	Substrate pin*1
3	GND	GND pin
4	V _{OUT}	Reset signal output pin
5	V _{CC}	V _{CC} pin/voltage detect pin

Note 1 : Connect to GND.

Absolute Maximum Ratings

Item	Symbol	Ratings	Unit
Storage temperature	T _{STG}	-40~+125	°C
Operating temperature	T _{OPR}	-20~+175	°C
Supply voltage	V _{CC} max.	-0.3~+110	V
Allowable loss	P _d	150	mW

Recommended Operating Conditions

Item	Symbol	Ratings	Unit
Operating temperature	T _{OPR}	-20~+75	°C
Supply voltage	V _{CC}	-0.3~+10	V

Electrical Characteristics (Except where noted otherwise, Ta=25°C)

Item	Symbol	Measurement circuit	Measurement conditions	Min.	Typ.	Max.	Unit	
Detecting voltage	V _s	1	V _{CC} =H→L R _L =4.7kΩ V _{OL} ≤ 0.4V	PST9246	4.531	4.600	4.669	V
				PST9245	4.432	4.500	4.568	
				PST9244	4.334	4.400	4.466	
				PST9243	4.235	4.300	4.365	
				PST9242	4.137	4.200	4.263	
				PST9241	4.038	4.100	4.162	
				PST9240	3.940	4.000	4.060	
				PST9239	3.841	3.900	3.959	
				PST9238	3.743	3.800	3.857	
				PST9237	3.644	3.700	3.756	
				PST9236	3.546	3.600	3.654	
				PST9235	3.447	3.500	3.553	
				PST9234	3.349	3.400	3.451	
				PST9233	3.250	3.300	3.350	
				PST9232	3.152	3.200	3.248	
				PST9231	3.053	3.100	3.147	
				PST9230	2.955	3.000	3.045	
				PST9229	2.856	2.900	2.944	
				PST9228	2.758	2.800	2.842	
				PST9227	2.659	2.700	2.741	
PST9226	2.561	2.600	2.639					
PST9225	2.462	2.500	2.538					
PST9224	2.364	2.400	2.436					
PST9223	2.265	2.300	2.335					
PST9222	2.167	2.200	2.233					
PST9221	2.068	2.100	2.132					
PST9220	1.970	2.000	2.030					
PST9219	1.871	1.900	1.929					

Item	Symbol	Measurement circuit	Measurement conditions	Min.	Typ.	Max.	Unit
Hysteresis voltage	ΔV_s	1	$V_{CC}=L \rightarrow H \rightarrow L, R_L=4.7k\Omega$ S1 : ON	25	50	100	mV
Detecting voltage temperature coefficient	$V_s/\Delta T$	1	$R_L=4.7k\Omega, T_a=-20\sim+75^\circ C$ S1 : ON		± 0.01		%/ $^\circ C$
Low level output voltage	V_{OL}	1	$V_{CC1}=V_{Smin.} -0.05V$ $R_L=4.7k\Omega$ S1 : ON		0.1	0.4	V
Output Leak current	I_{OH}	1	$V_{CC1}=V_{CC2}=10V$ S2 : ON			± 0.1	μA
Circuit current at ON time	I_{CCL}	1	$V_{CC1}=V_{Smin.} -0.05V$ $R_L=\infty$		5.0	9.0	μA
Circuit current at OFF time	I_{CCH}	1	$V_{CC1}=V_{Styp.}/0.85$ $R_L=\infty$		3.0	5.0	μA
"H" transmission delay time	T_{PLH}	2	$R_L=4.7k\Omega, C_L=100pF$ $C_d=0.01\mu F$ *1		(*3)		mS
"L" transmission delay time	T_{PHL}	2	$R_L=4.7k\Omega, C_L=100pF$ $C_d=0.01\mu F$ *2		(*3)		μS
Threshold operating voltage	V_{OPL}	1	$R_L=4.7k\Omega$ $V_{OL} \leq 0.4V$ S1 : ON		0.65	0.85	V
Output current at ON time 1	I_{OL1}	1	$V_{CC1}=V_{Smin.} -0.05V$ $V_{CC2}=0.4V$ S2 : ON	5			mA
Output current at ON time 2	I_{OL2}	1	$V_{CC1}=V_{Smin.} -0.05V$ $T_a=-20\sim+75^\circ C$ S2 : ON	3			mA

NOTE 1: T_{PLH} : $V_{CC}=(V_s \text{ typ. } -0.4V) \rightarrow (V_s \text{ typ. } +0.4V)$

NOTE 2 : T_{PLH} : $V_{CC}=(V_s \text{ typ. } +0.4V) \rightarrow (V_s \text{ typ. } -0.4V)$

NOTE 3 : Tables of PST92XX series transmission delay time

	T_{PLH}	T_{PHL}
PST9246	195	140
PST9245	190	140
PST9244	185	140
PST9243	180	140
PST9242	175	140
PST9241	170	140
PST9240	165	140
PST9239	160	140
PST9238	155	120
PST9237	150	120
PST9236	145	120
PST9235	140	120
PST9234	135	120
PST9233	130	120
PST9232	125	120
PST9231	120	120
PST9230	115	120
PST9229	110	120
PST9228	105	100
PST9227	100	100
PST9226	95	100
PST9225	90	100
PST9224	85	100
PST9223	80	100
PST9222	75	100
PST9221	70	100
PST9220	65	100
PST9219	60	100

Measuring Circuit

(1)

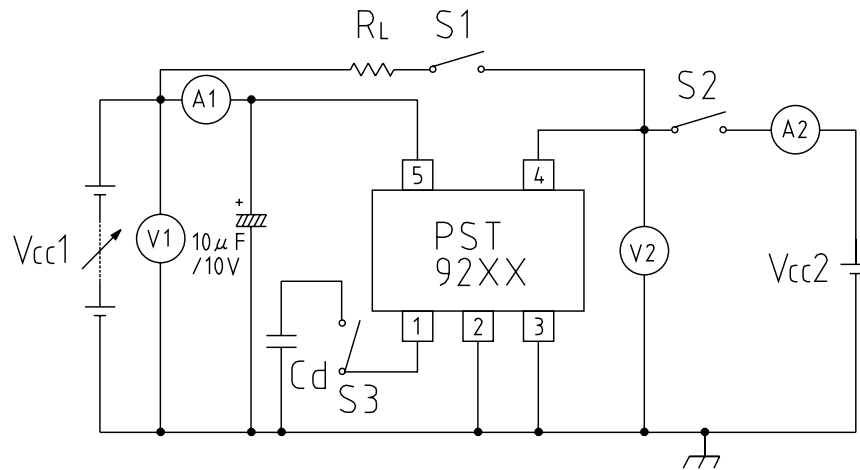

(2)

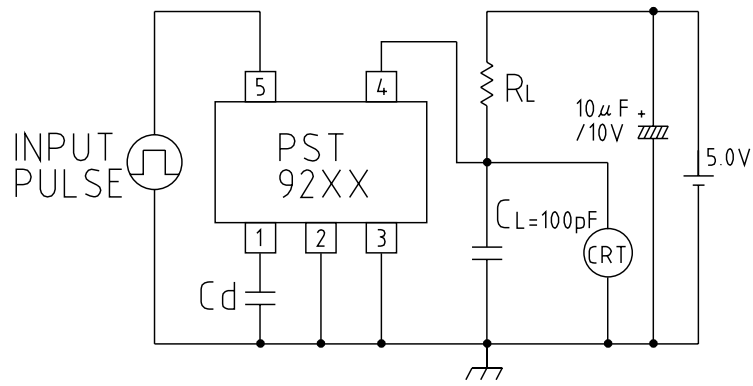

A : DC Amperemeter
 V : DC Voltmeter
 CRT : Oscilloscope

INPUT PULSE

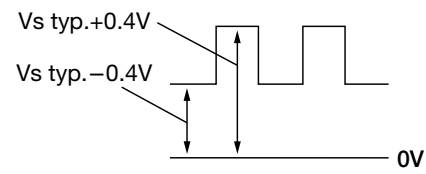

Timing Chart

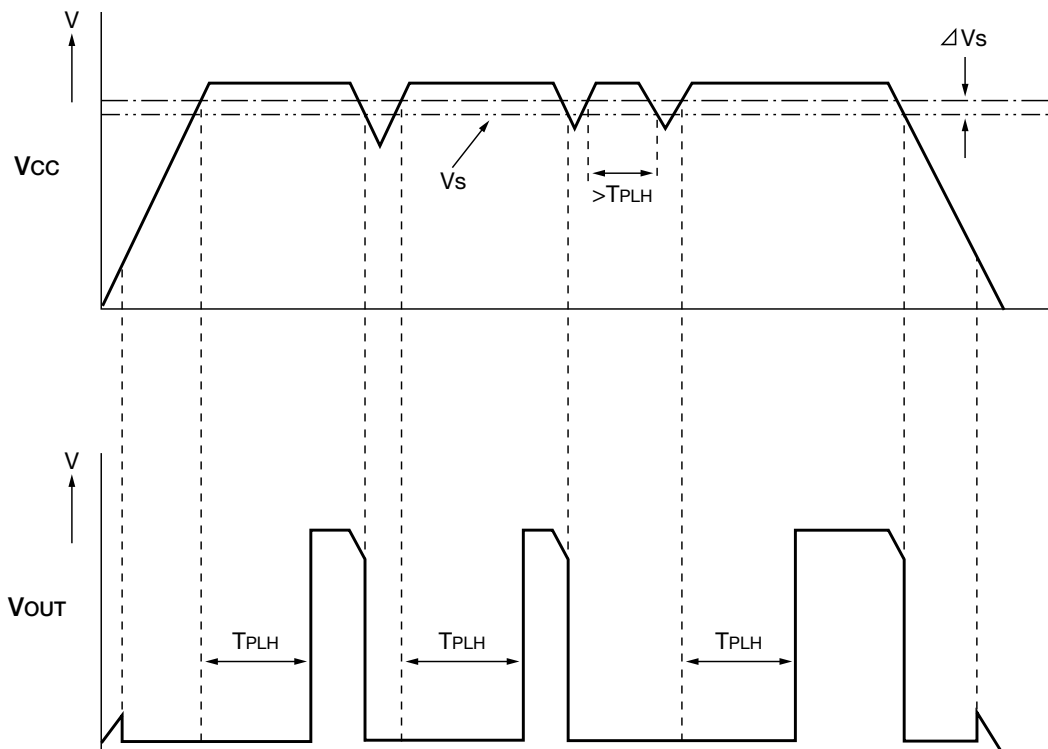

Application Circuit

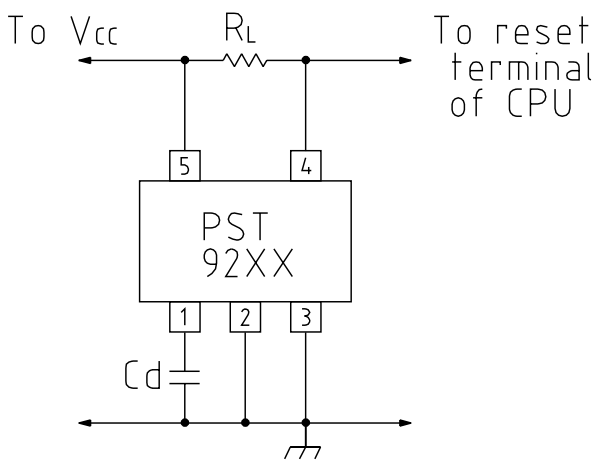

If the impedance of V_{CC} line is high enough, connect a capacitor between V_{CC} and GND terminal of the IC. (NOTE 1)

NOTE 1 : When the rapid noise occurs to V_{CC} , V_{OUT} has sometimes switched over even if V_{CC} doesn't become below V_s .

Characteristics

(1) V_{CC} vs V_{OUT}

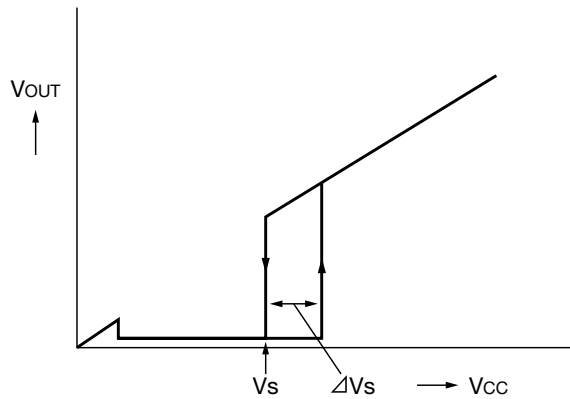

(2) C_d - T_{PLH}

Representative T_{PLH} Data : PST9220, PST9244

■ PST9220 C_d - T_{PLH} Characteristics

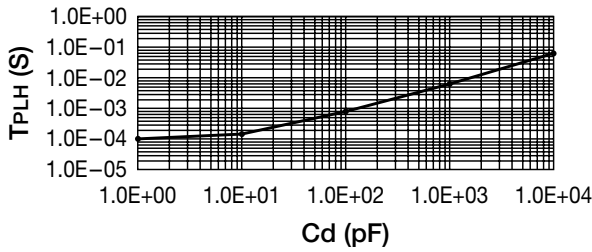

■ PST9244 C_d - T_{PLH} Characteristics

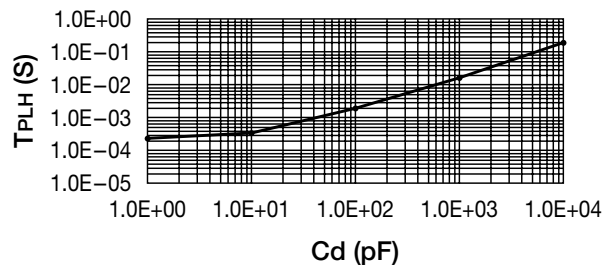

"H" transmission delay time can be calculated roughly using the following formula, but there is some fluctuation due to element deviation and the V_{CC} input signal (dV/dT).

$$T_{PLH} [\text{ms}] \approx C_d [\mu\text{F}] \times d$$

d: delay time coefficient

Model name	d	Model name	d	Model name	d
PST9246	1.95×10^4	PST9236	1.45×10^4	PST9226	0.95×10^4
PST9245	1.90×10^4	PST9235	1.40×10^4	PST9225	0.90×10^4
PST9244	1.85×10^4	PST9234	1.35×10^4	PST9224	0.85×10^4
PST9243	1.80×10^4	PST9233	1.30×10^4	PST9223	0.80×10^4
PST9242	1.75×10^4	PST9232	1.25×10^4	PST9222	0.75×10^4
PST9241	1.70×10^4	PST9231	1.20×10^4	PST9221	0.70×10^4
PST9240	1.65×10^4	PST9230	1.15×10^4	PST9220	0.65×10^4
PST9239	1.60×10^4	PST9229	1.10×10^4	PST9219	0.60×10^4
PST9238	1.55×10^4	PST9228	1.05×10^4		
PST9237	1.50×10^4	PST9227	1.00×10^4		