

# Video Switch · 75Ω driver · Y/C mix Monolithic IC MM1501 Series

## Outline

This IC extends the series of ICs for video/audio signal switching, with a 2-input 1-output single video switch, video signal/chroma signal 75Ω driver, and Y/C mixing circuit in one small package (SOT-26).

## Features

- (1) Low power consumption achieved.
- (2) Low power supply voltage realized.
- (3) Frequency bandwidth   without 75Ω driver: 10MHz                      with 75Ω driver: 7MHz
- (4) Cross talk   70dB   When 4.43MHz
- (5) With SAG measures pin (75Ω driver and Y/C mix driver)

## Package

- SOT-26A (with 75Ω driver)
- SOT-26B (without 75Ω driver)

## Applications

- (1) TV
- (2) VTR
- (3) Video camera
- (4) Digital still camera
- (5) Other visual equipment

## Line-up

Functions	Model Name	Input	Output	Clamp	6dB amp	75Ω driver	SAG measures pin	Power supply voltage
Switch	MM1501	2	1	×	×	×	×	4.5~13.0V
	MM1502			×	○	×	×	4.5~13.0V
	MM1503			○	×	×	×	4.5~13.0V
	MM1504			○	○	×	×	4.5~13.0V
	MM1505			×	×	○	×	4.5~13.0V
	MM1506			×	○	○	×	4.5~13.0V
	MM1507			○	×	○	×	4.5~13.0V
	MM1508			○	○	○	×	4.5~13.0V
Driver	MM1509	1	1	×	○	○	○	4.5~13.0V
	MM1510			○	○	○	○	4.5~13.0V
Y/C mix	MM1511	1	1	○/×	×	×	×	4.5~13.0V
	MM1512			○/×	○	○	○	4.5~13.0V

Block Diagram

MM1501

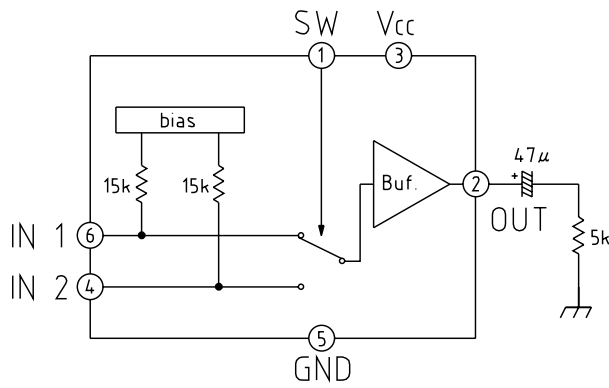

MM1502

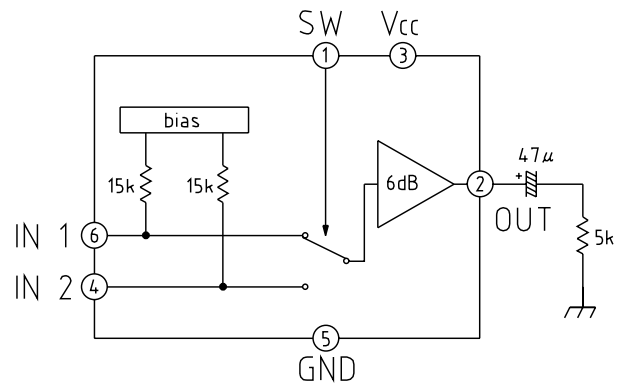

MM1503

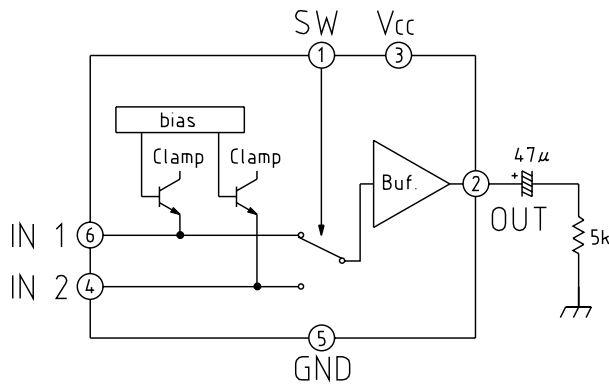

MM1504

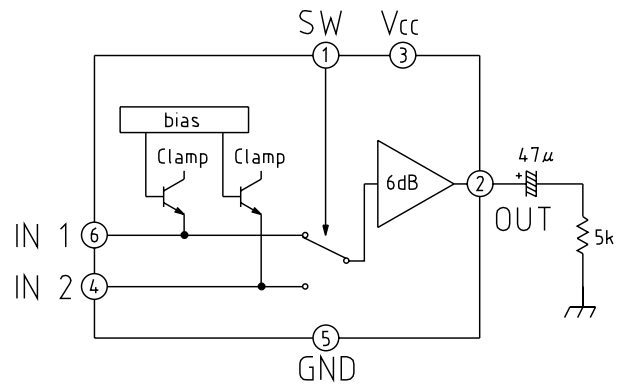

MM1505

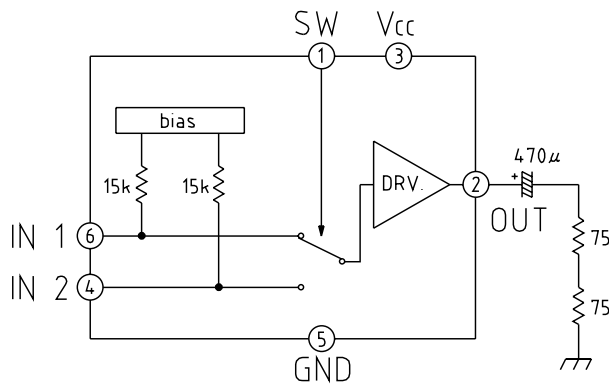

MM1506

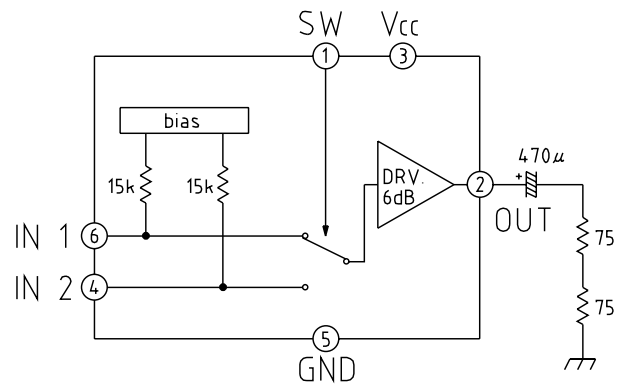

■ MM1507

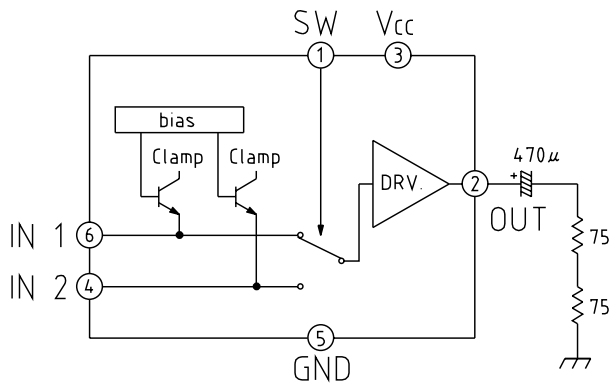

■ MM1508

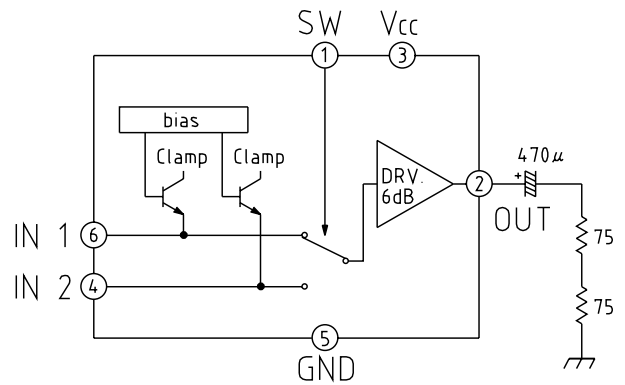

■ MM1509

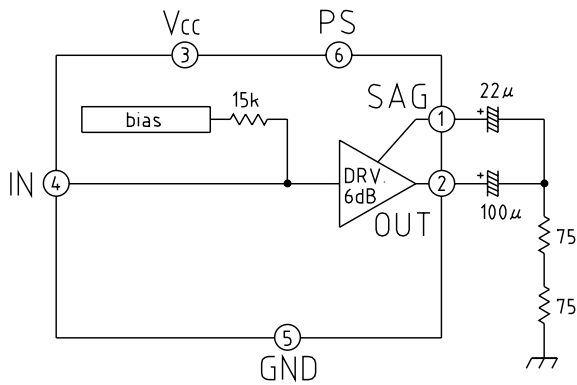

■ MM1510

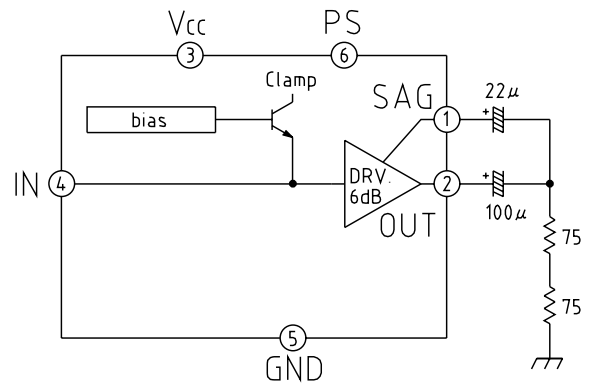

■ MM1511

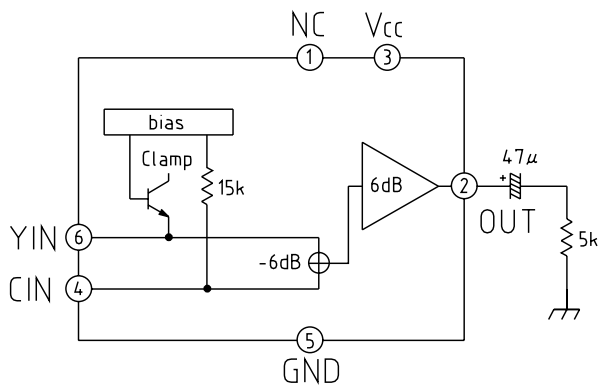

■ MM1512

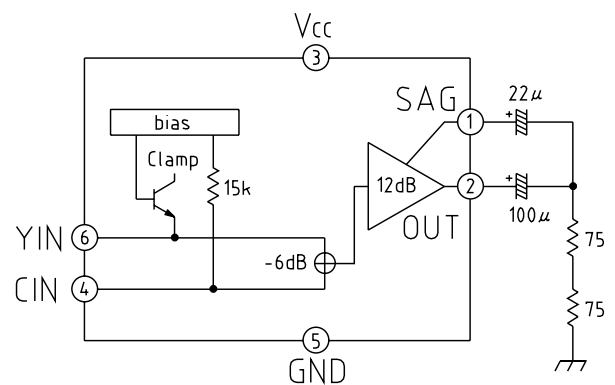

## Absolute Maximum Ratings (Ta=25°C)

Item	Symbol	Rating	Unit	
Storage temperature	T <sub>STG</sub>	-40~+125	°C	
Operating temperature	T <sub>OPR</sub>	-30~+75	°C	
Power supply voltage	V <sub>CC</sub>	15	V	
Allowable loss	When alone	P <sub>d</sub>	200	mW
	When mounted on board	P <sub>d</sub>	350 (★)	mW

\*Board size 100mm×100mm t=1.6

## Recommended Operating Conditions

Item	Symbol	Rating	Unit
Power supply voltage	V <sub>CC</sub>	4.5~13	V

## Electrical Characteristics (Except where noted otherwise, Ta=25°C, V<sub>CC</sub>=5V)

### MM1501

Item	Symbol	Measurement conditions	Min.	Typ.	Max.	Unit
Consumption current	I <sub>CC</sub>	Refer to measurement procedures		3.7	4.8	mA
Input pin voltage	V <sub>IN</sub>	No-signal, no-load	2.70	2.90	3.10	V
Output pin voltage	V <sub>OUT</sub>	No-signal, no-load		2.15		V
Voltage gain	G <sub>V</sub>	Refer to measurement procedures	-0.5	0	+0.5	dB
Frequency characteristic	f <sub>c</sub>	Refer to measurement procedures	-1	0	+1	dB
Differential gain	V <sub>CC</sub> =9V DG	Refer to measurement procedures	-3	0	+3	%
Differential phase	V <sub>CC</sub> =9V DP	Refer to measurement procedures	-3	0	+3	deg
Total harmonic distortion ratio	THD	Refer to measurement procedures		0.03	0.3	%
Output dynamic range	V <sub>D</sub>	Refer to measurement procedures	3.5	3.8		V
Output offset voltage	V <sub>OFF</sub>	Refer to measurement procedures			±15	mV
Cross talk	C <sub>T</sub>	Refer to measurement procedures		-70	-60	dB
SW input voltage H	V <sub>IH</sub>	Refer to measurement procedures	2.1			V
SW input voltage L	V <sub>IL</sub>	Refer to measurement procedures			0.7	V
Input impedance	Z <sub>i</sub>			15		kΩ
Output impedance	Z <sub>o</sub>			75		Ω

### MM1502

Item	Symbol	Measurement conditions	Min.	Typ.	Max.	Unit
Consumption current	I <sub>CC</sub>	Refer to measurement procedures		4.7	6.1	mA
Input pin voltage	V <sub>IN</sub>	No-signal, no-load	1.70	1.90	2.10	V
Output pin voltage	V <sub>OUT</sub>	No-signal, no-load		2.10		V
Voltage gain	G <sub>V</sub>	Refer to measurement procedures	5.5	6.0	6.5	dB
Frequency characteristic	f <sub>c</sub>	Refer to measurement procedures	-1	0	+1	dB
Differential gain	V <sub>CC</sub> =9V DG	Refer to measurement procedures	-3	0	+3	%
Differential phase	V <sub>CC</sub> =9V DP	Refer to measurement procedures	-3	0	+3	deg
Total harmonic distortion ratio	THD	Refer to measurement procedures		0.03	0.3	%
Output dynamic range	V <sub>D</sub>	Refer to measurement procedures	3.5	3.8		V
Output offset voltage	V <sub>OFF</sub>	Refer to measurement procedures			±30	mV
Cross talk	C <sub>T</sub>	Refer to measurement procedures		-70	-60	dB
SW input voltage H	V <sub>IH</sub>	Refer to measurement procedures	2.1			V
Sw input voltage L	V <sub>IL</sub>	Refer to measurement procedures			0.7	V
Input impedance	Z <sub>i</sub>			15		kΩ
Output impedance	Z <sub>o</sub>			12		Ω

■ MM1503

Item	Symbol	Measurement conditions	Min.	Typ.	Max.	Unit
Consumption current	I <sub>CC</sub>	Refer to measurement procedures		3.3	4.3	mA
Input pin voltage	V <sub>IN</sub>	No-signal, no-load	1.80	2.00	2.20	V
Output pin voltage	V <sub>OUT</sub>	No-signal, no-load		1.25		V
Voltage gain	G <sub>V</sub>	Refer to measurement procedures	-0.5	0	+0.5	dB
Frequency characteristic	f <sub>c</sub>	Refer to measurement procedures	-1	0	+1	dB
Differential gain	DG	Refer to measurement procedures	-3	0	+3	%
Differential phase	DP	Refer to measurement procedures	-3	0	+3	deg
Total harmonic distortion ratio	THD	Refer to measurement procedures		0.03	0.3	%
Output dynamic range	V <sub>D</sub>	Refer to measurement procedures	2.6	2.9		V
Output offset voltage	V <sub>OFF</sub>	Refer to measurement procedures			±15	mV
Cross talk	C <sub>T</sub>	Refer to measurement procedures		-70	-60	dB
SW input voltage H	V <sub>IH</sub>	Refer to measurement procedures	2.1			V
SW input voltage L	V <sub>IL</sub>	Refer to measurement procedures			0.7	V
Input impedance	Z <sub>o</sub>			75		Ω

■ MM1504

Item	Symbol	Measurement conditions	Min.	Typ.	Max.	Unit
Consumption current	I <sub>CC</sub>	Refer to measurement procedures		4.4	5.7	mA
Input pin voltage	V <sub>IN</sub>	No-signal, no-load	1.20	1.40	1.60	V
Output pin voltage	V <sub>OUT</sub>	No-signal, no-load		1.25		V
Voltage gain	G <sub>V</sub>	Refer to measurement procedures	5.5	6.0	6.5	dB
Frequency characteristic	f <sub>c</sub>	Refer to measurement procedures	-1	0	+1	dB
Differential gain	DG	Refer to measurement procedures	-3	0	+3	%
Differential phase	DP	Refer to measurement procedures	-3	0	+3	deg
Total harmonic distortion ratio	THD	Refer to measurement procedures		0.03	0.3	%
Output dynamic range	V <sub>D</sub>	Refer to measurement procedures	2.6	2.9		V
Output offset voltage	V <sub>OFF</sub>	Refer to measurement procedures			±30	mV
Cross talk	C <sub>T</sub>	Refer to measurement procedures		-70	-60	dB
SW input voltage H	V <sub>IH</sub>	Refer to measurement procedures	2.1			V
SW input voltage L	V <sub>IL</sub>	Refer to measurement procedures			0.7	V
Input impedance	Z <sub>o</sub>			12		Ω

■ MM1505

Item	Symbol	Measurement conditions	Min.	Typ.	Max.	Unit
Consumption current	I <sub>CC</sub>	Refer to measurement procedures		6.5	8.5	mA
Input pin voltage	V <sub>IN</sub>	No-signal, no-load	2.35	2.55	2.75	V
Output pin voltage	V <sub>OUT</sub>	No-signal, no-load		2.55		V
Voltage gain	G <sub>V</sub>	Refer to measurement procedures	-0.5	0.0	0.5	dB
Frequency characteristic	f <sub>c</sub>	Refer to measurement procedures	-1	0	+1	dB
Differential gain	V <sub>CC=9V</sub> DG	Refer to measurement procedures	-3	0	+3	%
Differential phase	V <sub>CC=9V</sub> DP	Refer to measurement procedures	-3	0	+3	deg
Output dynamic range	V <sub>D</sub>	Refer to measurement procedures	2.6	3.0		V
Output offset voltage	V <sub>OFF</sub>	Refer to measurement procedures			±15	mV
Cross talk	C <sub>T</sub>	Refer to measurement procedures		-70	-60	dB
SW input voltage H	V <sub>IH</sub>	Refer to measurement procedures	2.1			V
SW input voltage L	V <sub>IL</sub>	Refer to measurement procedures			0.7	V
Input impedance	Z <sub>i</sub>			15		kΩ

■ MM1506

Item	Symbol	Measurement conditions	Min.	Typ.	Max.	Unit
Consumption current	I <sub>CC</sub>	Refer to measurement procedures		6.8	8.8	mA
Input pin voltage	V <sub>IN</sub>	No-signal, no-load	1.75	1.95	2.15	V
Output pin voltage	V <sub>OUT</sub>	No-signal, no-load		2.35		V
Voltage gain	G <sub>V</sub>	Refer to measurement procedures	5.5	6.0	6.5	dB
Frequency characteristic	f <sub>c</sub>	Refer to measurement procedures	-1	0	+1	dB
Differential gain	V <sub>CC</sub> =9V DG	Refer to measurement procedures	-3	0	+3	%
Differential phase	V <sub>CC</sub> =9V DP	Refer to measurement procedures	-3	0	+3	deg
Output dynamic range	V <sub>D</sub>	Refer to measurement procedures	3.0	3.3		V
Output offset voltage	V <sub>OFF</sub>	Refer to measurement procedures			±30	mV
Cross talk	C <sub>T</sub>	Refer to measurement procedures		-70	-60	dB
SW input voltage H	V <sub>IH</sub>	Refer to measurement procedures	2.1			V
SW input voltage L	V <sub>IL</sub>	Refer to measurement procedures			0.7	V
Input impedance	Z <sub>i</sub>			15		kΩ

■ MM1507

Item	Symbol	Measurement conditions	Min.	Typ.	Max.	Unit
Consumption current	I <sub>CC</sub>	Refer to measurement procedures		6.4	8.3	mA
Input pin voltage	V <sub>IN</sub>	No-signal, no-load	1.15	1.35	1.55	V
Output pin voltage	V <sub>OUT</sub>	No-signal, no-load		1.35		V
Voltage gain	G <sub>V</sub>	Refer to measurement procedures	-0.5	0	+0.5	dB
Frequency characteristic	f <sub>c</sub>	Refer to measurement procedures	-1	0	+1	dB
Differential gain	DG	Refer to measurement procedures	-3	0	+3	%
Differential phase	DP	Refer to measurement procedures	-3	0	+3	deg
Output dynamic range	V <sub>D</sub>	Refer to measurement procedures	2.6	2.9		V
Output offset voltage	V <sub>OFF</sub>	Refer to measurement procedures			±15	mV
Cross talk	C <sub>T</sub>	Refer to measurement procedures		-70	-60	dB
SW input voltage H	V <sub>IH</sub>	Refer to measurement procedures	2.1			V
SW input voltage L	V <sub>IL</sub>	Refer to measurement procedures			0.7	V

■ MM1508

Item	Symbol	Measurement conditions	Min.	Typ.	Max.	Unit
Consumption current	I <sub>CC</sub>	Refer to measurement procedures		6.8	8.8	mA
Input pin voltage	V <sub>IN</sub>	No-signal, no-load	1.15	1.35	1.55	V
Output pin voltage	V <sub>OUT</sub>	No-signal, no-load		1.30		V
Voltage gain	G <sub>V</sub>	Refer to measurement procedures	5.5	6.0	6.5	dB
Frequency characteristic	f <sub>c</sub>	Refer to measurement procedures	-1	0	+1	dB
Differential gain	DG	Refer to measurement procedures	-3	0	+3	%
Differential phase	DP	Refer to measurement procedures	-3	0	+3	deg
Output dynamic range	V <sub>D</sub>	Refer to measurement procedures	2.6	3.0		V
Output offset voltage	V <sub>OFF</sub>	Refer to measurement procedures			±30	mV
Cross talk	C <sub>T</sub>	Refer to measurement procedures		-70	-60	dB
SW input voltage H	V <sub>IH</sub>	Refer to measurement procedures	2.1			V
SW input voltage L	V <sub>IL</sub>	Refer to measurement procedures			0.7	V

■ MM1509

Item	Symbol	Measurement conditions	Min.	Typ.	Max.	Unit
Consumption current	I <sub>CC1</sub>	Refer to measurement procedures		6.3	8.2	mA
Current consumption for PS	I <sub>CC2</sub>	Refer to measurement procedures		20	30	μA
PS input voltage L	V <sub>PSL</sub>	Refer to measurement procedures			0.3	V
PS input voltage H	V <sub>PSH</sub>	Refer to measurement procedures	1.8			V
Input pin voltage	V <sub>IN</sub>	No-signal, no-load	1.75	1.95	2.15	V
Output pin voltage	V <sub>OUT</sub>	No-signal, no-load		2.35		V
Voltage gain	G <sub>V</sub>	Refer to measurement procedures	5.5	6.0	6.5	dB
Frequency characteristic	f <sub>c</sub>	Refer to measurement procedures	-1	0	+1	dB
Differential gain	V <sub>CC=9V</sub> DG	Refer to measurement procedures	-3	0	+3	%
Differential phase	V <sub>CC=9V</sub> DP	Refer to measurement procedures	-3	0	+3	deg
Output dynamic range	V <sub>D</sub>	Refer to measurement procedures	2.9	3.2		V
Input impedance	Z <sub>i</sub>			15		kΩ

■ MM1510

Item	Symbol	Measurement conditions	Min.	Typ.	Max.	Unit
Consumption current	I <sub>CC1</sub>	Refer to measurement procedures		6.4	8.3	mA
Current consumption for PS	I <sub>CC2</sub>	Refer to measurement procedures		20	30	μA
PS input voltage L	V <sub>PSL</sub>	Refer to measurement procedures			0.3	V
PS input voltage H	V <sub>PSH</sub>	Refer to measurement procedures	1.8			V
Input pin voltage	V <sub>IN</sub>	No-signal, no-load	1.15	1.35	1.55	V
Output pin voltage	V <sub>OUT</sub>	No-signal, no-load		1.15		V
Voltage gain	G <sub>V</sub>	Refer to measurement procedures	5.5	6.0	6.5	dB
Frequency characteristic	f <sub>c</sub>	Refer to measurement procedures	-1	0	+1	dB
Differential gain	DG	Refer to measurement procedures	-3	0	+3	%
Differential phase	DP	Refer to measurement procedures	-3	0	+3	deg
Output dynamic range	V <sub>D</sub>	Refer to measurement procedures	2.6	3.0		V

■ MM1511

Item	Symbol	Measurement conditions	Min.	Typ.	Max.	Unit
Consumption current	I <sub>CC</sub>	Refer to measurement procedures		4.4	5.7	mA
Y input pin voltage	V <sub>YIN</sub>	No-signal, no-load	2.00	2.20	2.40	V
C input pin voltage	V <sub>CIN</sub>	No-signal, no-load	1.85	2.05	2.25	V
Output pin voltage	V <sub>OUT</sub>	No-signal, no-load		1.15		V
Voltage gain	G <sub>V</sub>	Refer to measurement procedures	-0.5	0	6.5	dB
Frequency characteristic	f <sub>c</sub>	Refer to measurement procedures	-1	0	+0.5	dB
Differential gain	DG	Refer to measurement procedures	-3	0	+3	%
Differential phase	DP	Refer to measurement procedures	-3	0	+3	deg
Y output dynamic range	V <sub>DY</sub>	Refer to measurement procedures	2.6	2.9		V
C output dynamic range	V <sub>DC</sub>	Refer to measurement procedures	2.0			V
C input impedance	Z <sub>i</sub>			15		kΩ
Output impedance	Z <sub>o</sub>			25		Ω

■ MM1512

Item	Symbol	Measurement conditions	Min.	Typ.	Max.	Unit
Consumption current	I <sub>CC</sub>	Refer to measurement procedures		6.9	9.0	mA
Y input pin voltage	V <sub>YIN</sub>	No-signal, no-load	1.95	2.15	2.35	V
C input pin voltage	V <sub>CIN</sub>	No-signal, no-load	1.80	2.00	2.20	V
Output pin voltage	V <sub>OUT</sub>	No-signal, no-load		1.10		V
Voltage gain	G <sub>V</sub>	Refer to measurement procedures	5.5	6.0	6.5	dB
Frequency characteristic	f <sub>c</sub>	Refer to measurement procedures	-1	0	+1	dB
Differential gain	DG	Refer to measurement procedures	-3	0	+3	%
Differential phase	DP	Refer to measurement procedures	-3	0	+3	deg
Y output dynamic range	V <sub>DY</sub>	Refer to measurement procedures	2.6	2.9		V
C output dynamic range	V <sub>DC</sub>	Refer to measurement procedures	2.0			V
C input impedance	Z <sub>i</sub>			15		kΩ

Measurement Procedures

■ MM1501~MM1508

· Switch Status

Item	Symbol	Switch status		
		S1	S2	S3
Consumption current	I <sub>CC</sub>	2	2	2
Voltage gain	G <sub>V</sub>	1	2	2
		2	1	1
Frequency characteristic	f <sub>c</sub>	1	2	2
		2	1	1
Differential gain	DG	1	2	2
		2	1	1
Differential phase	DP	1	2	2
		2	1	1

Item	Symbol	Switch status		
		S1	S2	S3
Total harmonic distortion ratio	THD	1	2	2
		2	1	1
Output dynamic range	V <sub>D</sub>	1	2	2
		2	1	1
Output offset voltage	V <sub>OFF</sub>	2	2	2
		2	2	1
Cross talk	C <sub>T</sub>	1	2	1
		2	1	2
SW input voltage H	V <sub>IH</sub>	2	2	1
SW input voltage L	V <sub>IL</sub>			



·Measurement Procedures (MM1501 ~ MM1504)

Consumption current	I <sub>CC</sub>	Connect a DC ammeter to V <sub>CC</sub> pin and measure. Hereafter, short the ammeter to use.
Voltage gain	G <sub>V</sub>	Input a 2.0V <sub>P-P</sub> (1.0V <sub>P-P</sub> for MM1502 and MM1504), 100kHz sine wave to SG1. If TP1 voltage is V1 and TP3 voltage is V2, find G <sub>V</sub> using the following formula: $G_V = 20\text{LOG} (V_2/V_1) \text{ dB}$
Frequency characteristic	f <sub>c</sub>	In the above G <sub>V</sub> measurement, if TP3 voltage at 10MHz is V3, find f <sub>c</sub> as follows: $f_c = 20\text{LOG} (V_3/V_2) \text{ dB}$
Differential gain	DG	Input a 2.0V <sub>P-P</sub> (1.0V <sub>P-P</sub> for MM1502 and MM1504) staircase to SG1 and measure differential gain at TP3. APL = 10 ~ 90%
Differential phase	DP	The same as for DG, but measure differential phase.
Total harmonic distortion ratio	THD	Input a 2.5V <sub>P-P</sub> (1.25V <sub>P-P</sub> for MM1502, MM1504), 1kHz sine wave to SG1, connect a distortion factor meter to TP3 and measure.
Output dynamic range	V <sub>D</sub>	Input a 100kHz sine wave to SG1. Change the amplitude of the sine wave, and measure V <sub>D</sub> , the maximum amplitude under THD 1%, at TP3.
Output offset voltage	V <sub>OFF</sub>	Measure the DC voltage difference of each switch status at TP2.
Cross talk	C <sub>T</sub>	VC1 = 2.1V and VC2 = 0.7V. Input a 2.0V <sub>P-P</sub> , 4.43MHz sine wave to SG1, and operate SW3. If TP3 voltage when there is an output signal on the OUT pin is V4, and when there is no signal TP3 voltage is V5, then find C <sub>T</sub> by the following formula: $C_T = 20\text{LOG} (V_5/V_4) \text{ dB}$
SW input voltage	V <sub>I</sub>	Impress an optional DC voltage on TP5 and TP6. Gradually increase from VC1 = 0V. When TP6 voltage is output on TP2, TP4 voltage is V <sub>IH</sub> . Gradually lower from VC1 = V <sub>CC</sub> , and when TP5 voltage is output on TP2, TP4 voltage is V <sub>IL</sub> .

· Measurement Procedures (MM1505 ~ MM1508)

Consumption current	I <sub>CC</sub>	Connect a DC ammeter to V <sub>CC</sub> pin and measure. Hereafter, short the ammeter to use.
Voltage gain	G <sub>V</sub>	Input a 2.0V <sub>P-P</sub> (1.0V <sub>P-P</sub> for MM1506 and MM1508), 100kHz sine wave to SG1. If TP1 voltage is V1 and TP3 voltage is V2, find G <sub>V</sub> using the following formula: $G_V = 20\text{LOG} (V_2/V_1) \text{ dB}$
Frequency characteristic	f <sub>c</sub>	In the above G <sub>V</sub> measurement, if TP3 voltage at 7MHz is V3, find f <sub>c</sub> as follows: $f_c = 20\text{LOG} (V_3/V_2) \text{ dB}$
Differential gain	DG	Input a 2.0V <sub>P-P</sub> (1.0V <sub>P-P</sub> for MM1506 and MM1508) staircase to SG1 and measure differential gain at TP3. APL = 10 ~ 90%
Differential phase	DP	The same as for DG, but measure differential phase.
Output dynamic range	V <sub>D</sub>	Input a 100kHz sine wave to SG1. Change the amplitude of the sine wave, and measure V <sub>D</sub> , the maximum amplitude under THD 1%, at TP3.
Output offset voltage	V <sub>OFF</sub>	Measure the DC voltage difference of each switch status at TP2.
Cross talk	C <sub>T</sub>	VC1 = 2.1V and VC2 = 0.7V. Input a 2.0V <sub>P-P</sub> , 4.43MHz sine wave to SG1, and operate SW3. IF TP3 voltage when there is an output signal on the OUT pin is V4, and when there is no signal TP3 voltage is V5, then find C <sub>T</sub> by the following formula: $C_T = 20\text{LOG} (V_5/V_4) \text{ dB}$
SW input voltage	V <sub>I</sub>	Impress an optional DC voltage on TP6 and TP7. Gradually increase from VC1 = 0V. When TP7 voltage is output on TP2, TP5 voltage is V <sub>IH</sub> . Gradually lower from VC1 = V <sub>CC</sub> , and when TP6 voltage is output on TP2, TP5 voltage is V <sub>IL</sub> .

■ MM1509 ~ MM1510

· Switch Status

Item	Symbol	Switch status	
		S1	S2
Consumption current	I <sub>CC1</sub>	2	1
Consumption current for PS	I <sub>CC2</sub>	2	3
PS input voltage L	V <sub>IL</sub>	2	2
PS input voltage H	V <sub>IH</sub>		
Voltage gain	G <sub>V</sub>	1	1

Item	Symbol	Switch status	
		S1	S2
Frequency characteristic	f <sub>c</sub>	1	1
Differential gain	DG	1	1
Differential phase	DP	1	1
Output dynamic range	V <sub>D</sub>	1	1

· Measurement Procedures

Consumption current	I <sub>CC1</sub>	Connect a DC ammeter to the V <sub>CC</sub> pin and measure.
Consumption current for PS	I <sub>CC2</sub>	Connect a DC ammeter to the V <sub>CC</sub> pin and measure.
PS input voltage	V <sub>I</sub>	Connect a DC ammeter to the V <sub>CC</sub> pin. Gradually lower from VC1 = V <sub>CC</sub> . VC1 voltage when consumption current is reduced from I <sub>CC1</sub> to 110% of I <sub>CC2</sub> is V <sub>IL</sub> . Gradually raise from VC1 = 0V. VC1 voltage when consumption current increases from I <sub>CC2</sub> to 90% of I <sub>CC1</sub> is V <sub>IH</sub> . From here on, short the ammeter when using it.
Voltage gain	G <sub>V</sub>	Input a 1.0V <sub>P-P</sub> , 100kHz sine wave to SG1. If TP1 voltage is V1 and TP2 voltage is V2, find G <sub>V</sub> by the following formula: $G_V = 20\text{LOG} (V_2/V_1) \text{ dB}$
Frequency characteristic	f <sub>c</sub>	In the above G <sub>V</sub> measurement, if TP2 voltage at 7MHz is V3, find f <sub>c</sub> by the following formula. $f_c = 20\text{LOG} (V_3/V_2) \text{ dB}$
Differential gain	DG	Input a 1.0V <sub>P-P</sub> staircase to SG1 and measure differential gain at TP2. APL = 10 ~ 90%
Differential phase	DP	The same as for DG, but measure differential phase.
Output dynamic range	V <sub>D</sub>	Input a 100kHz sine wave to SG1. Measure DR, the maximum amplitude under THD 1%, at TP2.

■ MM1511 ~ MM1512

· Switch Status

Item	Symbol	Switch status	
		S1	S2
Consumption current	I <sub>CC</sub>	2	2
Voltage gain	G <sub>V</sub>	1	2
		2	1
Frequency characteristic	f <sub>c</sub>	1	2
		2	1

Item	Symbol	Switch status	
		S1	S2
Differential gain	DG	3	1
Differential phase	DP	3	1
Y output dynamic range	V <sub>DY</sub>	2	1
C output dynamic range	V <sub>DC</sub>	3	1

· Measurement Procedures

Consumption current	I <sub>CC1</sub>	Connect a DC ammeter to the V <sub>CC</sub> pin and measure. Hereafter, short the ammeter to use.
Voltage gain	G <sub>V</sub>	Input a 2.0V <sub>P-P</sub> (1.0V <sub>P-P</sub> for MM1512), 100kHz sine wave to SG1. If TP1 voltage is V1 and TP2 voltage is V2, find G <sub>V</sub> by the following formula: $G_V = 20\text{LOG} (V_2/V_1) \text{ dB}$
Frequency characteristic	f <sub>c</sub>	In the above G <sub>V</sub> measurement, if TP2 voltage at 10MHz (7MHz for MM1512) is V3, find f <sub>c</sub> by the following formula. $f_c = 20\text{LOG} (V_3/V_2) \text{ dB}$
Differential gain	DG	Input a 2.0V <sub>P-P</sub> (1.0V <sub>P-P</sub> for MM1512) to SG1, input a chroma signal to SG2, and measure differential gain at TP2. APL = 10 ~ 90%
Differential phase	DP	The same as for DG, but measure differential phase.
Y output dynamic range	V <sub>DY</sub>	Input a 100kHz sine wave to SG1. Measure V <sub>DY</sub> , the maximum amplitude under THD 1%, at TP2.
C output dynamic range	V <sub>DC</sub>	Input an APL 50% luminance signal to SG1 and input a chroma signal to SG2. Change the chroma signal amplitude and measure V <sub>DC</sub> , the maximum amplitude where there is no waveform distortion at TP2.

Measuring Circuit

■ MM1501

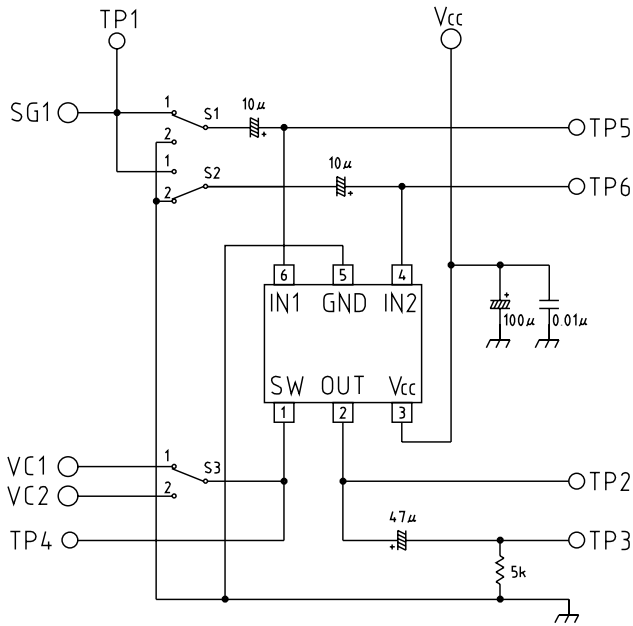

■ MM1502

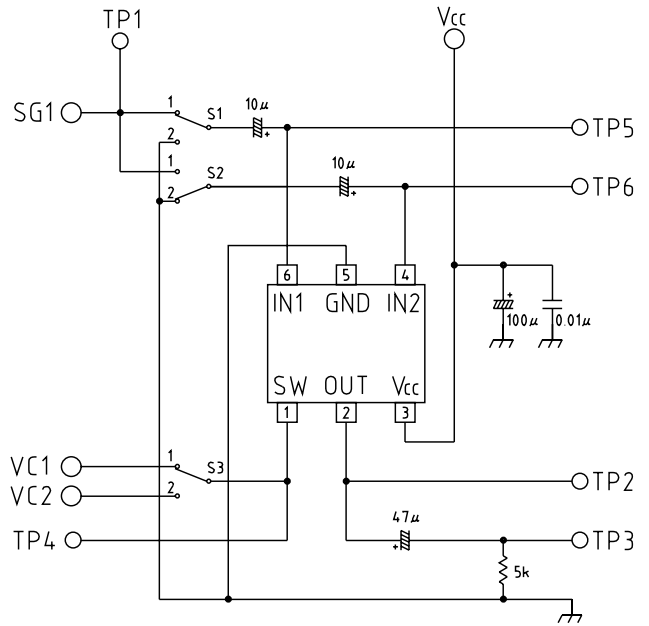

■ MM1503

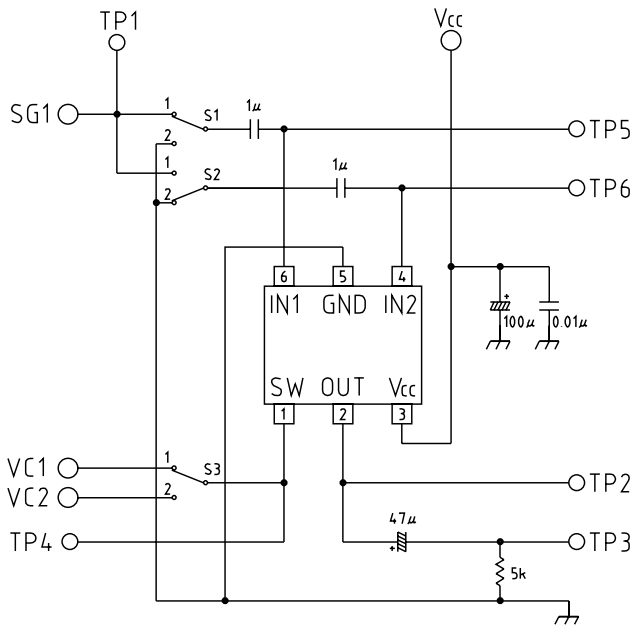

■ MM1504

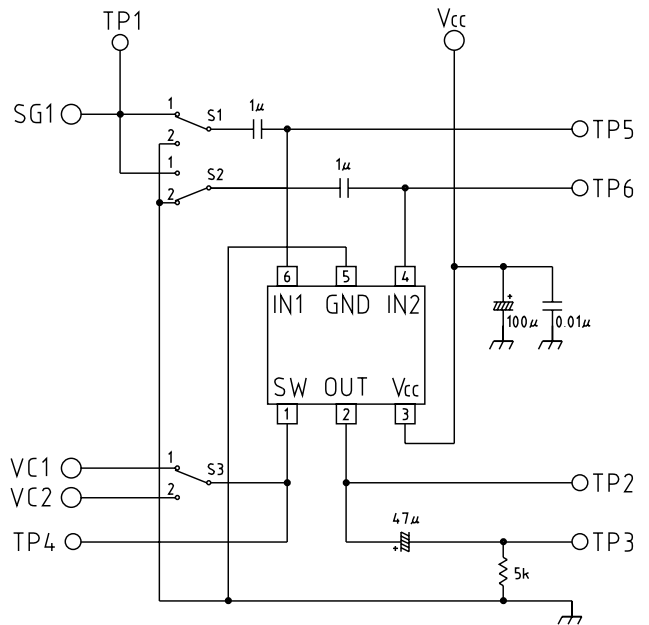

■ MM1505

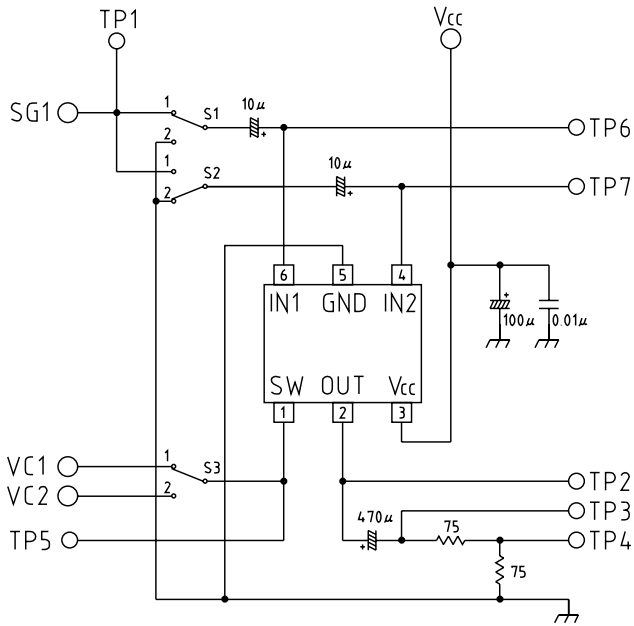

■ MM1506

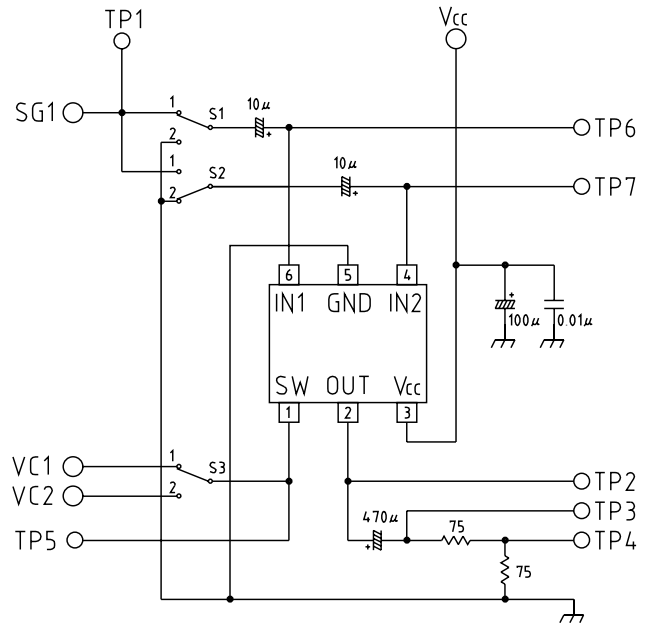

■ MM1507

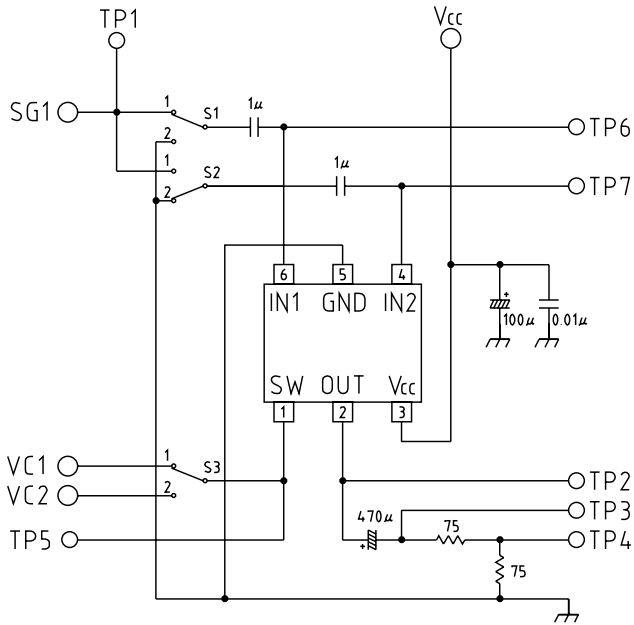

■ MM1508

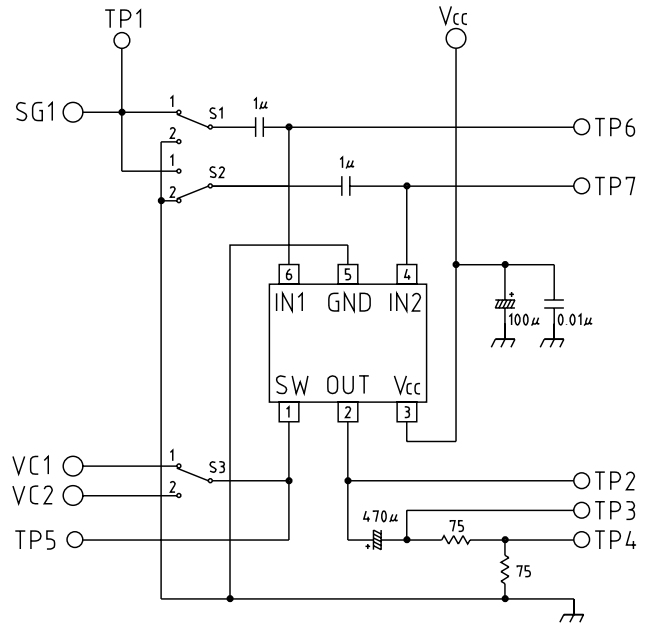

■ MM1509

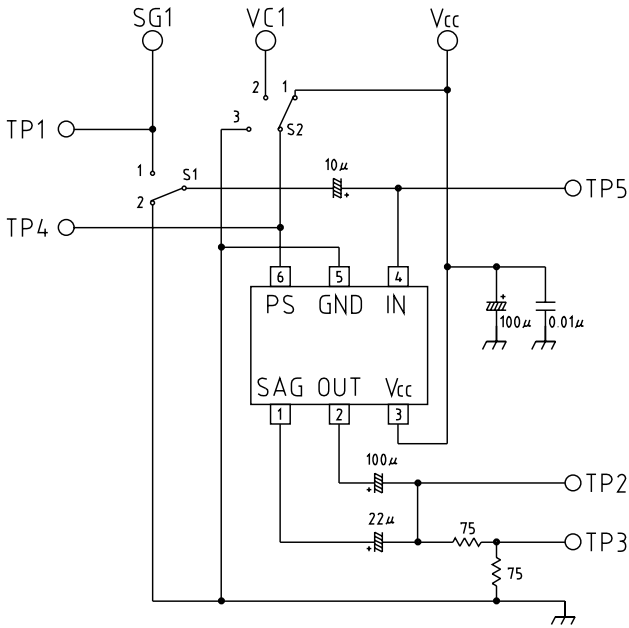

■ MM1510

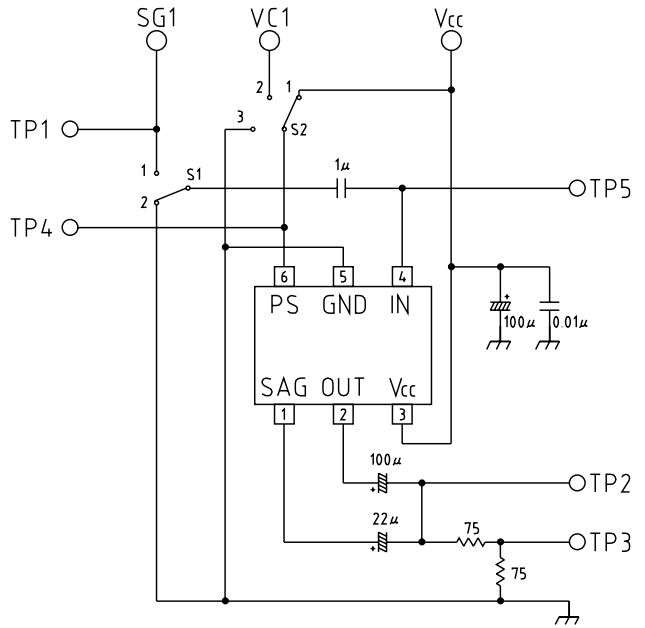

■ MM1511

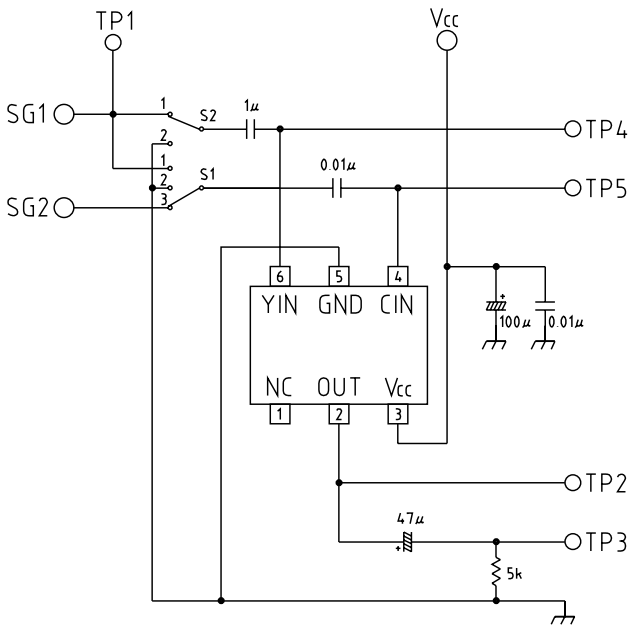

■ MM1512

