

85MHz RGB Video Amplifier/130MHz RGB Video Amplifier Monolithic IC MM1207, 1205

Outline

MM1207XD and MM1205XD are wideband RGB video amplifiers with DC control, developed for use in monitors. The main differences between MM1207XD and MM1205XD are video amp bandwidth and output rise time, and output fall time. Other characteristics are the same.

Model	MM1207	MM1205
Video amp band	85MHz	130MHz
Output rise time	4.3nS	2.6nS
Output fall time	4.3nS	3.6nS

MM1207 is described here as the representative model.

MM1207 is a wideband video amps system developed for use in high resolution RGB monitors. In addition to three matched video amps, it has a gate controlled differential input black level comparator for luminance adjustment, three matched DC control attenuators for contrast adjustment, and three gain trimming CD control subcontrast attenuators for white balance. All DC control input is high impedance, and the operating range is set for easy interface with serial bus control systems, at 0~4V. Also, MM1207's built-in blanking circuit clamps video output to between GND~0.1V during blanking, enabling blanking on the CRT cathode.

Features

1. Built-in wideband video amp 85MHz @ -3dB (4V_{P-P} output)
2. Matched (±0.1dB or 1.2%) contrast adjustment attenuators built-in
3. Built-in cutoff and luminance adjustment single end input comparators with external gate control
4. Gain of each video amp controlled independently
5. Built-in high input impedance DC contrast control, 0~4V (> 40dB range)
6. Built-in high input impedance DC drive control, 0~4V (±3dB range)
7. 7V_{P-P} output swing (band slightly attenuated)
8. Output blanking function
9. Output can drive almost all hybrid or discrete CRT drivers directly

Package

DIP-28B (MM1207XD, MM1205XD)

Applications

1. High resolution RGB CRT monitors
2. AGC amps for video
3. Gain and DC offset control
4. Interface amps for LCD or CCD systems

Block Diagram

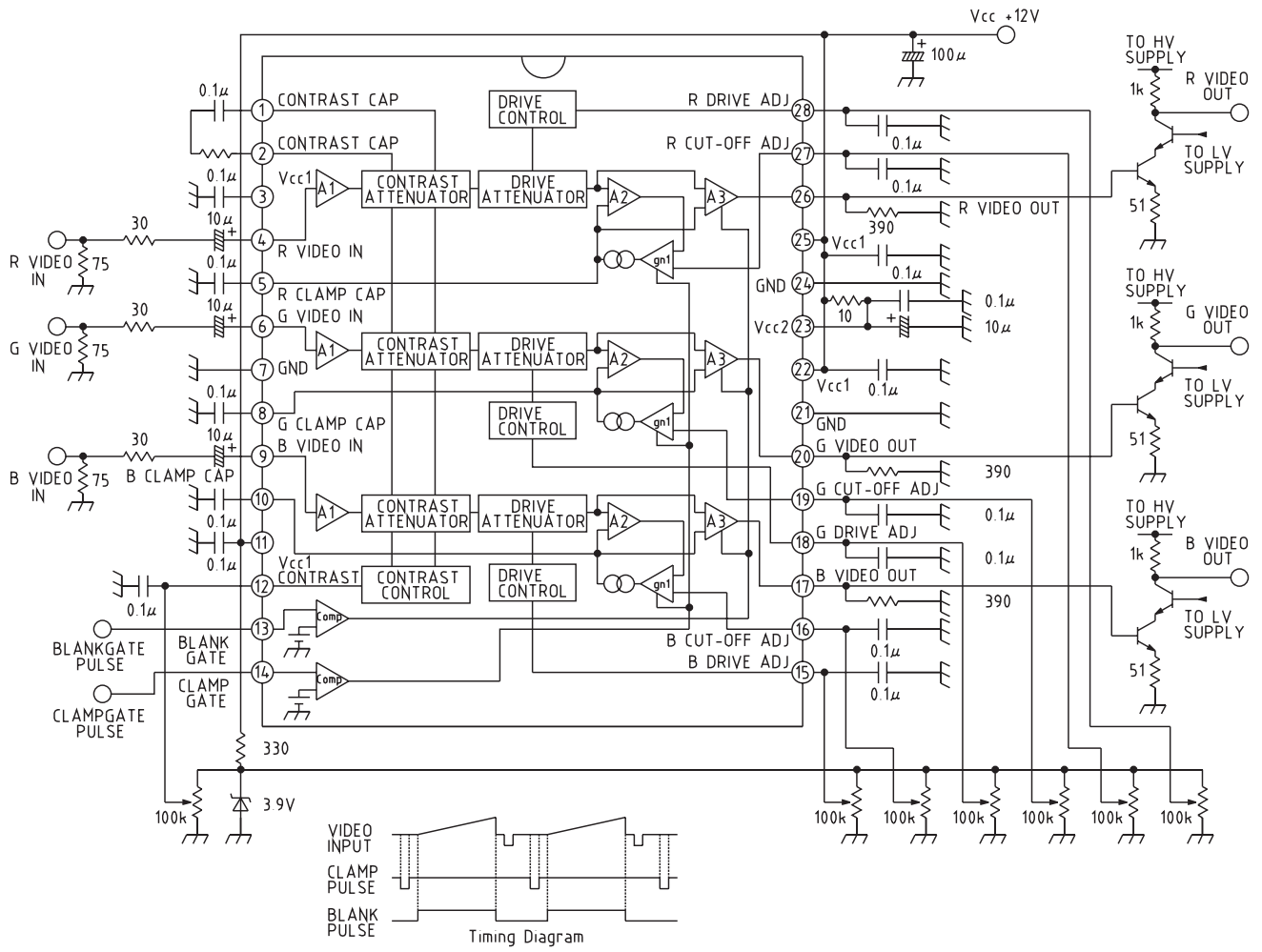

Pin Description

Pin no.	Pin name	Internal equivalent circuit diagram	Pin no.	Pin name	Internal equivalent circuit diagram
1, 2	CONTRAST CAP		13	BLANK GATE	
			14	CLAMP GATE	
3, 11 22, 25	VCC1		15 18 28	B DRIVE ADJ G DRIVE ADJ R DRIVE ADJ	
4 6 9	R VIDEO IN G VIDEO IN B VIDEO IN				
5 8 10	R CLAMP CAP G CLAMP CAP B CLAMP CAP				
7, 21 24	GND		16	B CUT-OFF ADJ	
			17 20 26	R VIDEO OUT G VIDEO OUT B VIDEO OUT	
12	CONTRAST		23	Vcc2	

Absolute Maximum Ratings (Ta=25°C)

Item	Symbol	Ratings	Units
Storage temperature	T _{STG}	-65~+150	°C
Operating temperature	T _{OPR}	-20~+80	°C
Power supply voltage	V _{CC}	13.5	V
Pin input voltage	V _{IN}	GND ≤ V _{IN} ≤ V _{CC}	V
Video output current	I _o	28	mA
Allowable loss	P _d	2.5	W
Electrostatic breakdown 1		2	kV
Electrostatic breakdown 2		1	kV
Pin temperature		265	°C

Recommended Operating Conditions (Ta=25°C)

Item	Symbol	Min.	Typ.	Max.	Units
Operating voltage	V _{CC}	10.8	12.0	13.2	V

DC Electrical Characteristics (Ta=25°C, V_{CC}=12V, V_{I2}=4V, V_{I4}=0V, V_{C-0}=1V, V_{DRV}=4V, S1~3=OFF, S4~6=1)

Item	Symbol	Measurement conditions	Min.	Typ.	Max.	Units
Consumption current	I _{CC1}	V _{CC1} +V _{CC2} , R _L =∞		90	105	mA
Video amp input voltage	V _B			2.8		V
Video input resistance	R _B			20	20	kΩ
Clamp gate input voltage L	V _{CGL}		0.8	1.2		V
Clamp gate input voltage H	V _{CGH}			1.6	2.0	V
Clamp gate input current L	I _{CGL}	V _{I4} =0V		-0.5	-5.0	μA
Clamp gate input current H	I _{CGH}	V _{I4} =12V		0.005	1.0	μA
Clamping capacitor charge current	I _{CL+}		500	750		μA
Clamping capacitor discharge current	I _{CL-}		-500	-750		μA
Clamping capacitor bias discharge current	I _{CLB}	S5=2		500		nA
Blanking gate input voltage L	V _{BGL}	S4=2	0.8	1.2		V
Blanking gate input voltage H	V _{BGH}	S4=2		1.6	2.0	V
Blanking gate input current L	I _{BGL}	V _{I3} =0V, S4=2	-5.0	-1.0		μA
Blanking gate input current H	I _{BGH}	V _{I3} =12V, S4=2	0.01	1.0		μA
Video output voltage L	V _{OL}	V _{C-0} =0V		0.15	0.5	V
Video output voltage H	V _{OH}	V _{C-0} =9V	7.0	7.5		V
Video black level output voltage	V _O	V _{C-0} =1V		0.9		V
Video Δblack level output voltage	ΔV _O	V _{C-0} =1V		±100		mV
Video output blanking voltage	ΔV _{OBL}	V _{I3} =0V		35	70	mV
Contrast control input current	I _{I2}	V _{I2} =0~4V		-250		μA
Drive control input current	I _{DRV}	V _{DRV} =0~4V		-250		μA
Cutoff control input current	I _{C-0}	V _{C-0} =0~4V		-500		μA

AC Electrical Characteristics (Ta=25°C, Vcc=12V, S1~3=ON, S4, 5=1, S6=2)

Item	Symbol	Measurement conditions	Min.	Typ.	Max.	Units
Video amp gain	Av max.	VIN=635mVP-P	5.4	7.0		V/V
		V12=4V, VDRV=4V	14.6	16.9		dB
Gain attenuation 1	ΔAv1	VIN=635mVP-P, V12=2V		-6		dB
Gain attenuation 2	ΔAv2	VIN=635mVP-P, V12=0.5V		-38		dB
Drive control range	ΔAVDR	VDRV=0~4V, V12=4V		6		dB
Gain matching	AVMAT	VDRV=V12=4V		0.3		dB
Gain change between amps	ΔAVM1	V12=4~2V		0.1		dB
Gain attenuation matching	THD	VOUT=1VP-P		1		%
Video amp frequency bandwidth	fBW	VOUT=4VP-P, VDRV=V12=4V		85		MHz
Output rise time	tr	VOUT=4VP-P		4.3		nS
Output fall time	tf	VOUT=4VP-P		4.3		nS
Crosstalk 1	VSEP1	V12=4V		-70		dB
Crosstalk 2	VSEP2	V12=4V		-50		dB
Blanking output fall time	tBLK	VOUT=1VP-P, S4=2		7		nS
Blanking output fall time	tBLK	VOUT=1VP-P, S4=2		7		nS
Back-porch clamping pulse width	tpw					nS

Measuring Circuit

