

IC for Headphone Stereos (bass boost) Monolithic IC LAG 668

Outline

This IC was developed to provide bass boost functions without deviating from the basic design concept of Mitsumi's LAG665, which is highly regarded for applications in headphone stereos for overseas markets in particular.

Bass boost functions are widely adopted in models for overseas markets as well. However, because of stringent cost constraints, there has been a need for an IC which is simple and inexpensive. This IC can provide bass boost functions simply by adding three resistors and one capacitor (per channel).

Moreover, it has the same pinout as the LAG665, so that by making selective use of set features, a product lineup can be developed without changes to the printed circuit board.

Features

1. Configuration: pre and power amps, motor control, E. VR, bass boost
2. Preamp off function convenient for use in models with radios
3. Independent motor control circuit
 1. Motor noise is effectively suppressed
 2. With motor on/off pin (motor can be stopped easily when radio is in use)
 3. With fast forward pin
4. Bass boost frequency characteristic can be changed simply by changing the resistance multiplier.
5. Well-balanced E. VR circuit
 1. L, R channels variable using a single VR
 2. A-curve can be reproduced using B-curve VR
6. Few external components

Package

- SOP-28B (LAG668F)
- SDIP-30A (LAG668D)

Absolute Maximum Ratings

Item	Symbol	Ratings	Units
Operating temperature	T _{OPR}	-20~+65	°C
Storage temperature	T _{STG}	-40~+125	°C
Power supply current	V _{CC} max.	-0.3~+7.5	V
Power consumption	P _d	DIP : 750, SOP : 450	mW
Operating voltage	V _{OP}	+2.0~+5.0	V

Electrical Characteristics (Except where noted otherwise, Ta=25°C)

Item	Symbol	Measurement conditions	Min.	Typ.	Max.	Units
Consumption current	I _{cc}	V _{IN} =0V, I _M =0mA		18	25	mA
Preamp unit (Ta=25°C)						
Open-circuit gain	G _{vo}	V _O =-10dBm, R _L =infinite		72		dB
Closed-circuit gain	G _{vc}	V _O =-10dBm	40	42	44	dB
Maximum output voltage	V _{om}	THD=10%	0.45	0.6		V _{rms}
Total harmonic distortion ratio	THD	V _{OUT} =400mV _{rms}		0.05	0.5	%
Output noise voltage	V _{no}	V _{IN} =0, R _g =2.2k, BPF (30~20kHz)		150	300	μV _{rms}
Input impedance	Z _{IN}	V _{OUT} =-10dBm	18	22		kΩ
Crosstalk between channels	C.T	R _g =2.2k, V _{OUT} =-10dBm	30			dB
Output voltage with pre off	V _{ooff}	V _{IN} =100mV _{rms}			-50	dB
Output resistance with pre off	R _{ooff}			10		kΩ
Input resistance on pre off	R _{ioff}			10		kΩ
Attenuator unit (Ta=25°C)						
Maximum input voltage	V _i max.		0.2			V _{rms}
Maximum attenuation	V _a max.	V _{cont} =min.	66			dB
Attenuation error	V _{aerr}	V _{cont} =max.		0		dB
Input impedance	Z _{IN}		200			kΩ
Control pin input resistance	Z _{icot}		100			kΩ
Power amp unit (Ta=25°C)						
Voltage gain	G _v	P _{OUT} =5mW	36	38	40	dB
Voltage gain difference between channels	ΔG _v	V _{cont} =max.		0	3	dB
Maximum output power I	P _{om1}	THD=10%, R _L =32Ω	20	28		mW
Maximum output power II	P _{om2}	THD=10%, R _L =16Ω	30			mW
Total harmonic distortion ratio	THD	P _{OUT} =5mW		0.5	2.0	%
Crosstalk between channels	C.T	P _{OUT} =5mW	20	30		dB
Output noise voltage	V _n	R _g =2.2k, V _{cont} =max.		1.0	2.0	mV _{rms}
Ripple rejection	RR	V _{CC} =3V, 100Hz, 100mV _{p-p}	31	37		dB
Noise of preamp + power amp + B.B.	V _{nto}	V _{IN} =0, R _g =2.2k, V _{cont} =max. *1		3.0	6.0	mV _{rms}
Motor control unit (Ta=25°C)						
Consumption current	I _{MC}			3.0	5.0	mA
Startup current	I _{MS}		500			mA
Reference voltage	V _{ref}	Between RML-ADJ pins	0.72	0.80	0.87	V
Reference voltage fluctuation I	V _{ref1}	V _{CC} between 2.1 and 5.0 V		0.05		%/V
Reference voltage fluctuation II	V _{ref2}	I _M between 25 and 250 mA		0.01		%/mA
Reference voltage fluctuation III	V _{ref3}	Ta between -10 and 50°C		0.01		%/°C
Current coefficient	K		32	38	43	
Current coefficient fluctuation I	K1	V _{CC} between 2.1 and 5.0 V		0.5		%/V
Current coefficient fluctuation II	K2	I _M between 25 and 250 mA		0.05		%/mA
Current coefficient fluctuation III	K3	Ta between -10 and 50°C		0.02		%/°C
Output voltage on forced on	V _{CEsa}	I _M =200mA, 14PIN=V _{CC}			0.6	V
Input resistance on forced on	R _{ion}			5.6		kΩ
Leakage current on forced off	I _{ML}				200	μA
Input resistance on forced off	R _{icon}			33		kΩ

*Conditions unless stated otherwise

Amp unit: V_{CC}=3.0V, f=1kHz, R_L=16Ω, Pre OFF=OPEN

Motor unit: V_{CC}=3.0V, I_M=100mA, Motor unit: (Mitsumi model)

Note 1: Bass boost circuit constants are based on application circuit diagrams.

Note 2: Motor pin voltage fluctuations

Block Diagram

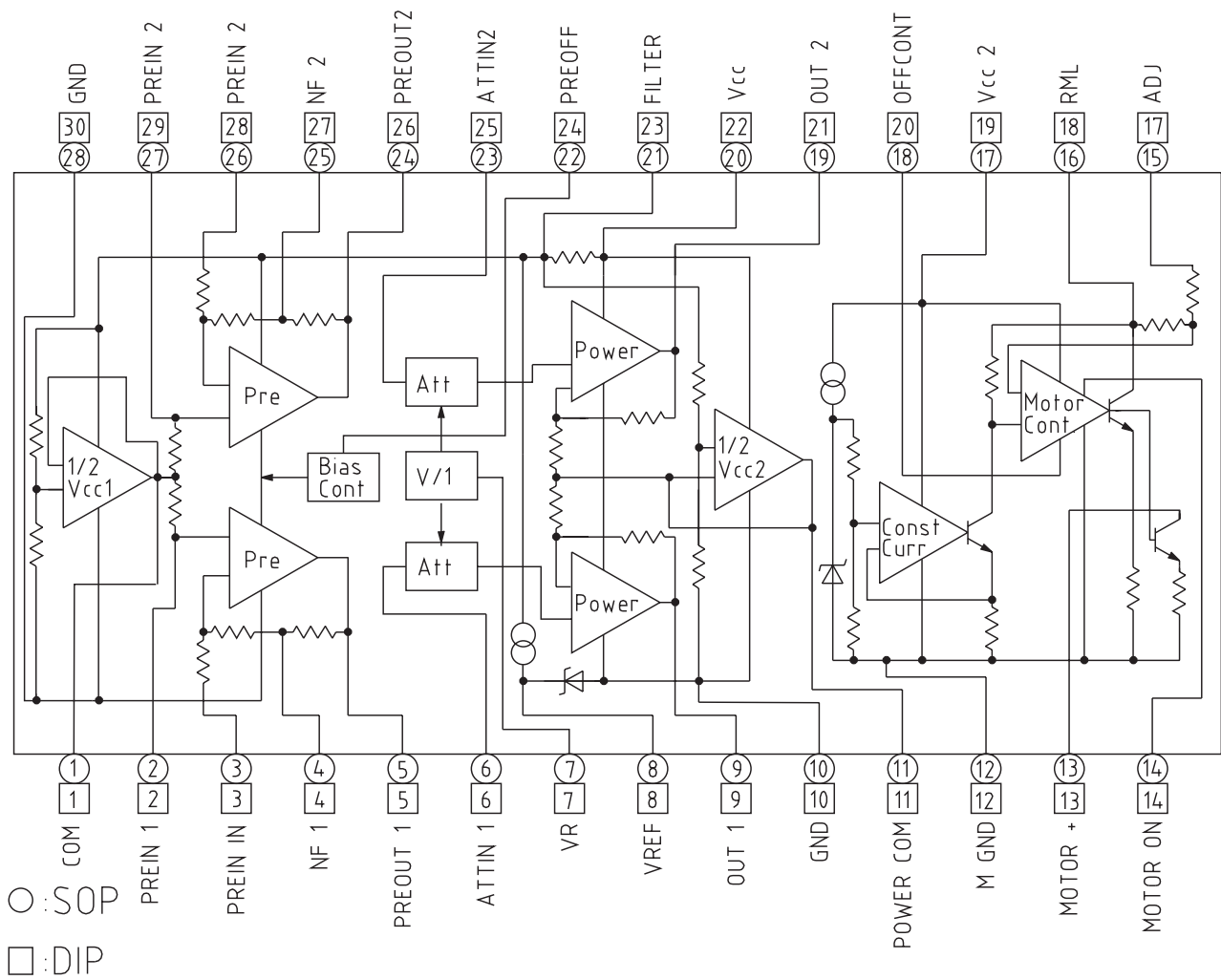

Application Circuits

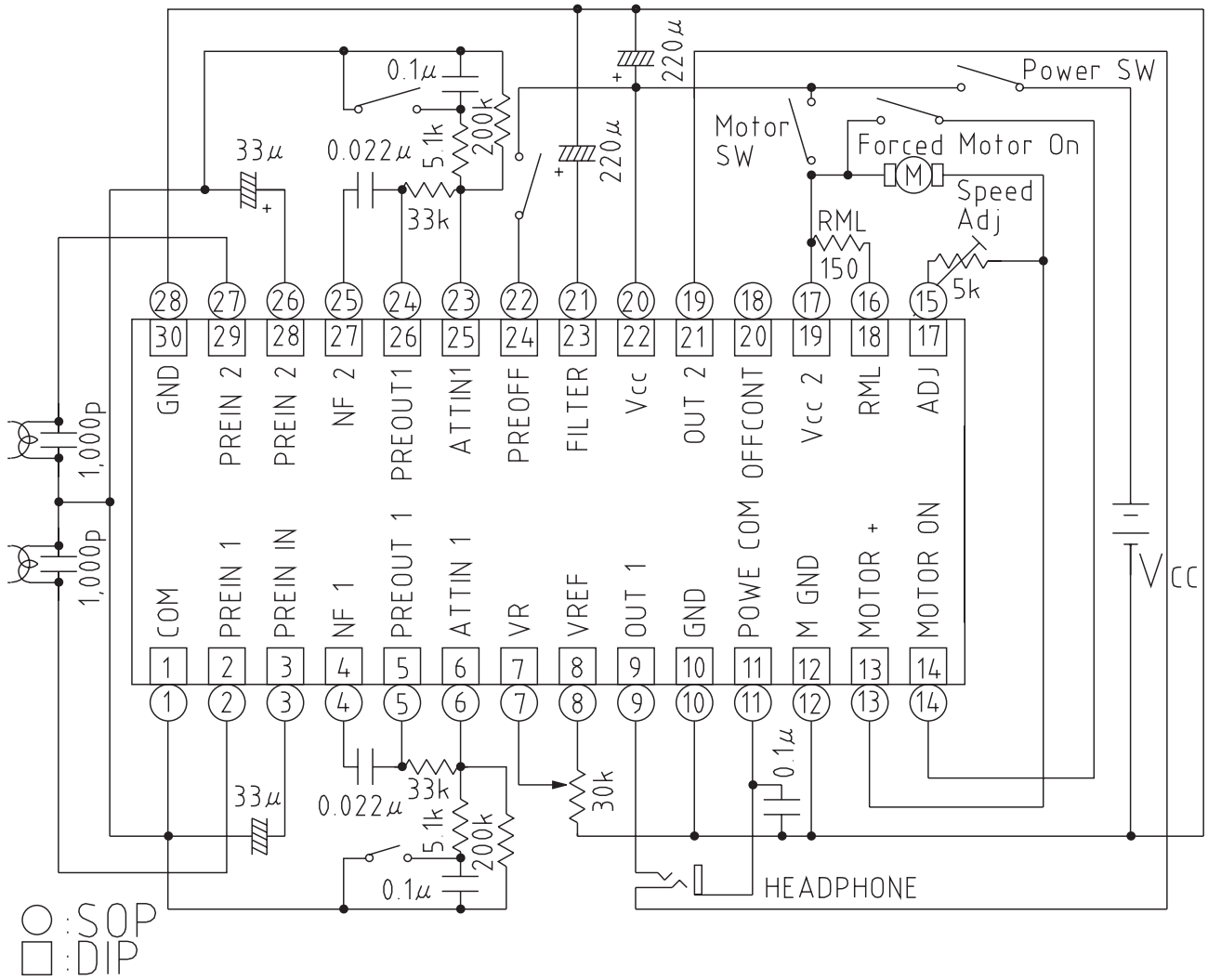

Bass Boost Power Amp Gain

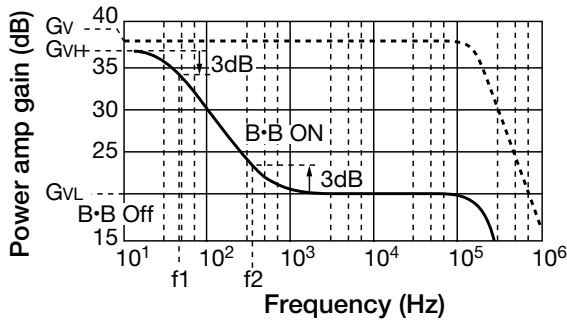

Gv : Power amp gain
 GvH : Bass boost power amp gain (high level)
 GvL : Bass boost power amp gain (low level, or boost off)
 f1, f2: Cutoff frequencies

$$GvH = Gv + 20 \log \left(\frac{R3}{R1 + R3} \right) \text{ (dB)}$$

$$GvL = Gv + 20 \log \left(\frac{R2 / R3 \times R1}{R2 / R3 + R1} \right) \text{ (dB)}$$

$$f1 = \frac{1}{2\pi ((R1 // R3) + R2) C} \text{ (Hz)}$$

$$f2 = \frac{1}{2\pi R2 C} \text{ (Hz)}$$

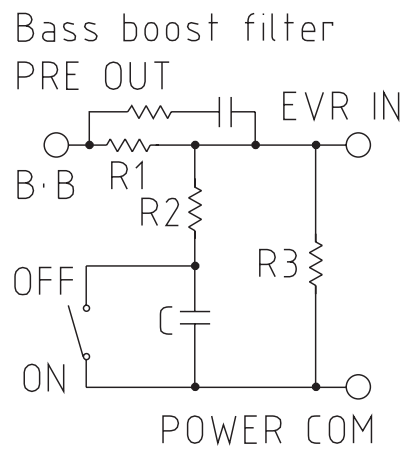

Characteristics (Bass boost)

■ Recommended constants

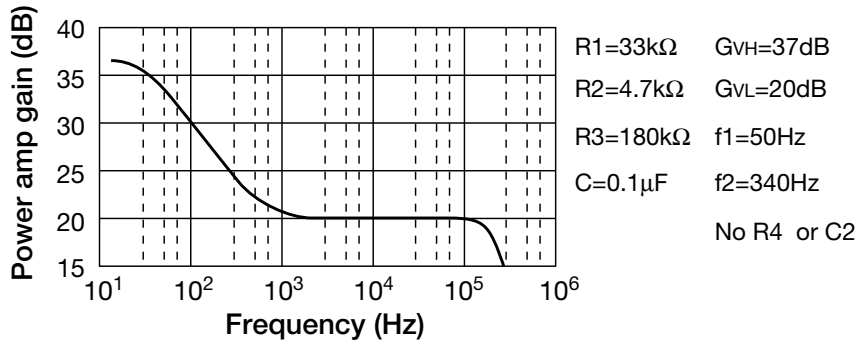

■ Bass boost efficiency

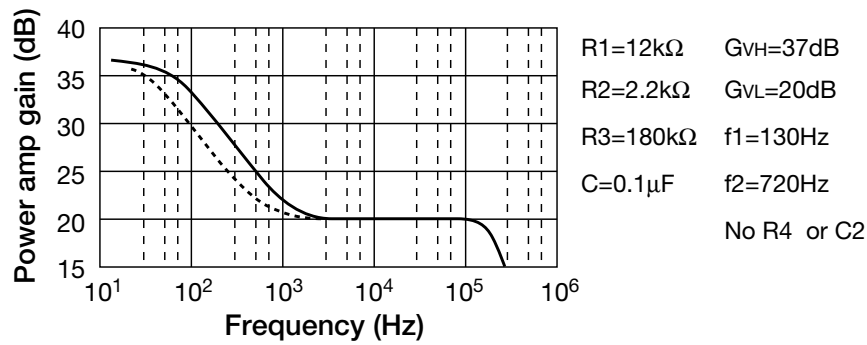

■ Response for poor headphone and cassette head characteristics

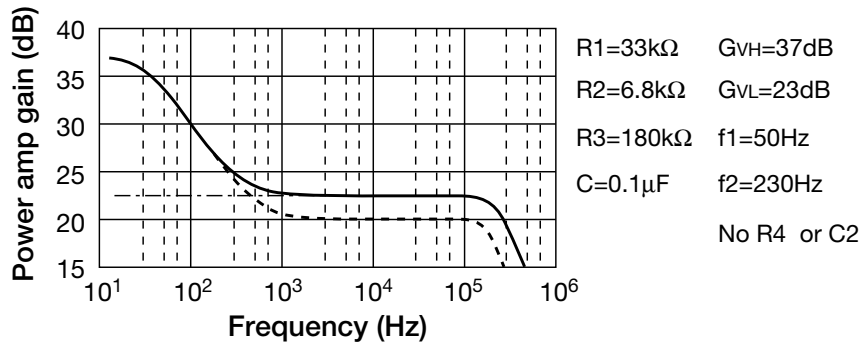

■ Bass + treble boost

