

Regulator+Reset IC Monolithic IC MM1481

Outline

This IC was developed for use in CD-ROM drives and other optical disc drives. It combines two 3V system regulator lines and reset (monitors regulator input) with a built-in 4.2V detection delay circuit that responds to market needs.

Features

- 1. Large output current 300mA max.
- 2. High ripple rejection rate regulator1: 80dB typ. regulator2: 60dB typ.
- 3. Internal thermal shutdown circuit.
- 4. Internal current-limiting circuit.
- 5. Adjustment-free reset detection voltage 4.2V typ.
- 6. Easy to set delay time from voltage detection to reset release.

Package

VSOP-8A

Applications

- 1. CD-ROM drive
- 2. Optical disc drives

Pin Assignment

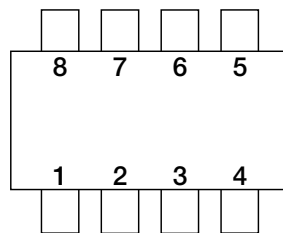

VSOP-8A
(TOP VIEW)

1	Cd
2	RESET
3	Vdet
4	V _{IN}
5	V _{OUT1}
6	V _{OUT2}
7	GND
8	CONT

Equivalent Circuit Diagram

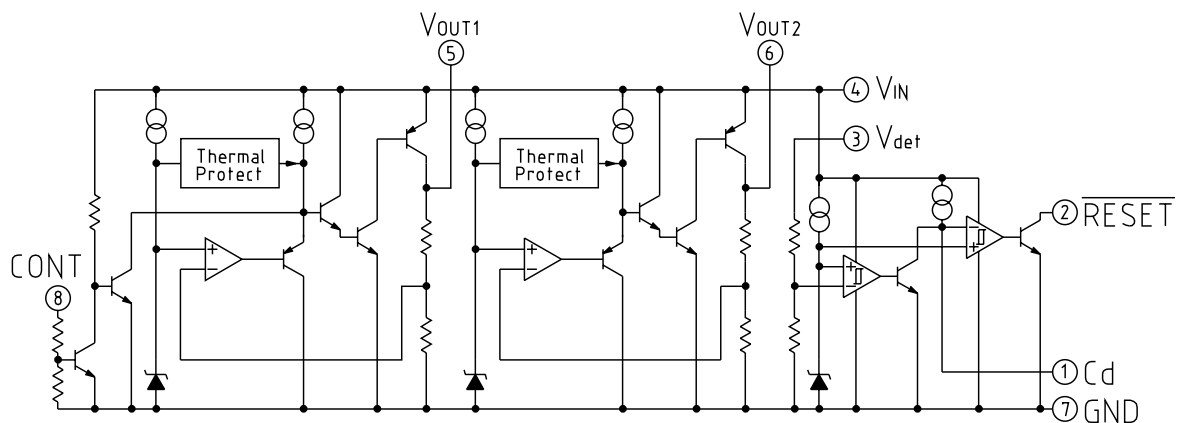

Pin Description

Pin No.	Pin Name	Functions	Equivalent circuit diagram						
1	Cd	<p>Delay time capacitor pin</p> <p>The delay time of RESET output can be set according to the capacity value connected with Cd</p> <p>$t_{PLH}=450000 \cdot C$</p> <p>t_{PLH1}: Delay Time [s]</p> <p>C: Cd-capacitance [F]</p>							
2	RESET	<p>$\overline{\text{RESET}}$ -output pin</p> <p>$\overline{\text{RESET}}$ pin logic</p> <table border="1"> <tr> <td></td> <td>$\overline{\text{RESET}}$</td> </tr> <tr> <td>Vdet<VS</td> <td>L</td> </tr> <tr> <td>Vdet>VS</td> <td>H</td> </tr> </table> <p>When the voltage of VIN decreases to 1.6V or less, it is likely to become "L" regardless of Vdet voltage.</p>		$\overline{\text{RESET}}$	Vdet<VS	L	Vdet>VS	H	
	$\overline{\text{RESET}}$								
Vdet<VS	L								
Vdet>VS	H								
3	Vdet	Voltage-supply pin (reset)							
4	VIN	Voltage-supply pin							
5	VOUT1	Regulator output pin (150mA)							
6	VOUT2	Regulator output pin (100mA)							
7	GND	GND pin							
8	CONT	<p>VOUT1 ON/OFF-control pin</p> <table border="1"> <tr> <td>VCONT</td> <td>VOUT1</td> </tr> <tr> <td>L</td> <td>OFF</td> </tr> <tr> <td>H</td> <td>ON</td> </tr> </table> <p>Connect cont-terminal with VIN, when it is not used.</p>	VCONT	VOUT1	L	OFF	H	ON	
VCONT	VOUT1								
L	OFF								
H	ON								

Absolute Maximum Ratings

Item	Symbol	Ratings	Unit
Storage temperature	T _{STG}	-40~+125	°C
Supply voltage	V _{IN}	-0.3~+10	V
Output current 1	I _{OUT1}	300	mA
Output current 2	I _{OUT2}	200	mA
Power dissipation	P _d	550*	mW

Note: * When mounted on a (Copper foil area 80%, 100×100×1.6^t mm) glass epoxy board.

Recommended Operating Conditions (Except where noted otherwise, Ta=25°C)

Item	Symbol	Ratings	Unit
Operating temperature	T _{OP}	-20~+85	°C
Output current 1	I _{OP1}	0~150	mA
Output current 2	I _{OP2}	0~100	mA
Operating voltage	V _{OP}	0~10	V

Electrical Characteristics (Except where noted otherwise, Ta=25°C, V_{CONT}=1.6V)

Item	Symbol	Measurement conditions	Min.	Typ.	Max.	Unit
V _{IN} Input Current 1	I _{CCQ1}	V _{IN} =5V I _{OUT1} =I _{OUT2} =0mA		2.1	4.2	mA
V _{IN} Input Current 2 (V _{OUT1} -OFF)	I _{CCQ2}	V _{IN} =5V V _{cont} =0.4V I _{OUT2} =0mA		300	500	μA
V _{det} Input Current 1	I _{CCQ3}	V _{det} =5V		20	40	μA
Regulator 1 (150mA output)						
Output Voltage	V _{OUT1}	V _{IN} =5V I _{OUT1} =30mA	3.52	3.60	3.68	V
Input-Output differential Voltage	V _{iO}	V _{IN} =3.4V I _{OUT1} =70mA		0.13	0.26	V
Line Regulation	ΔV ₁	V _{IN} =4.4V~5.5V I _{OUT1} =30mA		1	20	mV
Load Regulation	ΔV ₂	V _{IN} =5V I _{OUT1} =0mA~150mA		20	120	mV
V _{OUT} Temperature Coefficient *1	ΔV _{OUT} /ΔT	T _j =-20~+80°C V _{IN} =5V I _{OUT1} =30mA		100		ppm/°C
Ripple Rejection *1	RR	V _{IN} =5V f=120Hz V _{RIPPLE} =1V _{P-P} , I _{OUT1} =30mA	50	80		dB
Output Noise Voltage *1	V _n	V _{IN} =5V, f=20~80kHz I _{OUT1} =30mA		100		μV _{rms}
CONT Terminal Current when ON	I _{ON}	V _{cont} =1.6V		5	10	μA
HIGH Threshold Voltage	H		1.6		V _{IN} +0.3	V
LOW Threshold Voltage	L		-0.3		0.4	V
Regulator 2 (100mA output)						
Output Voltage	V _{OUT2}	V _{IN} =5V I _{OUT2} =20mA	3.52	3.60	3.68	V
Input-Output differential Voltage	V _{iO}	V _{IN} =3.4V I _{OUT2} =20mA		0.07	0.14	V
Line Regulation	ΔV ₁	V _{IN} =4.4V~5.5V I _{OUT2} =20mA		10	20	mV
Load Regulation	ΔV ₂	V _{IN} =5V I _{OUT2} =0mA~100mA		20	120	mV
V _{OUT} Temperature Coefficient *1	ΔV _{OUT} /ΔT	T _j =-20~+80°C V _{IN} =5V I _{OUT2} =20mA		100		ppm/°C
Ripple Rejection *1	RR	V _{IN} =5V f=120Hz V _{RIPPLE} =1V _{P-P} , I _{OUT2} =20mA	50	60		dB
Output Noise Voltage *1	V _n	V _{IN} =5V, f=20~80kHz I _{OUT2} =20mA		150		μV _{rms}

Note 1: design guaranteed

Electrical Characteristics (Typical model MM1481C) (Except where noted otherwise, Ta=25°C, VCONT=1.6V)
 (Except where noted otherwise, resistance unit is Ω)

■ Part of RESET

Item	Symbol	Measurement conditions	Min.	Typ.	Max.	Unit
Detecting Voltage	VS	Vdet=H→L	4.11	4.20	4.29	V
Vs temperature Coefficient *	$\Delta VS/\Delta T$	Ta=-20~+80°C		100		ppm/°C
Hysteresis Voltage	ΔVS	Vdet=H→L→H	100		200	mV
Low-Level Output Voltage	VOL	Vdet=3.9V RL=4.7k		100	200	mV
Output Leakage Current	IOH	Vdet=5V			±0.1	μA
Output Current when ON 1	IO1	Vdet=3.9V, RL=0	5			mA
Output Current when ON 2 *	IO2	Vdet=3.9V, RL=0 Ta=-20~+80°C	3			mA
"H" Transmission Delay Time *	tPLH	Cd Pin open		30	90	μs
Reset Delay Time *	tPLH1	Vdet=4V→5V, Cd=0.22μF	5	10	15	ms
"L" Transmission Delay Time *	tPHL	Cd Pin open		30	90	μs
Threshold Operating Voltage	VOPL	VOL=0.4V		0.65	0.85	V

Note 1: design guaranteed

Measuring Circuit

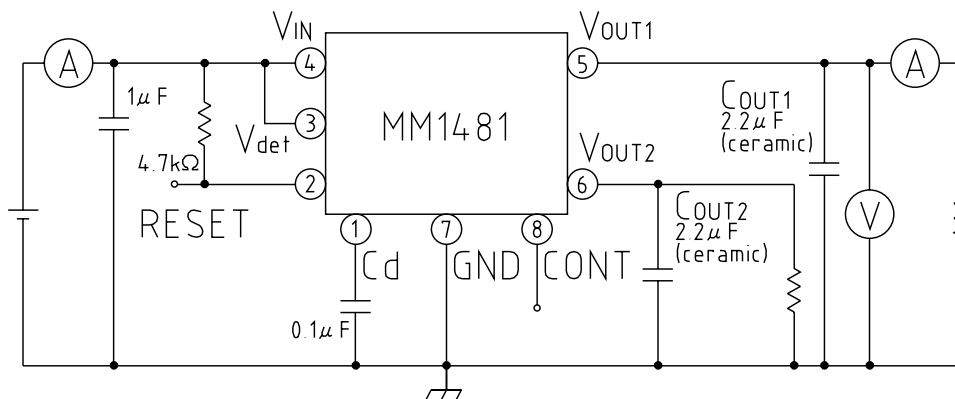

Application Circuit

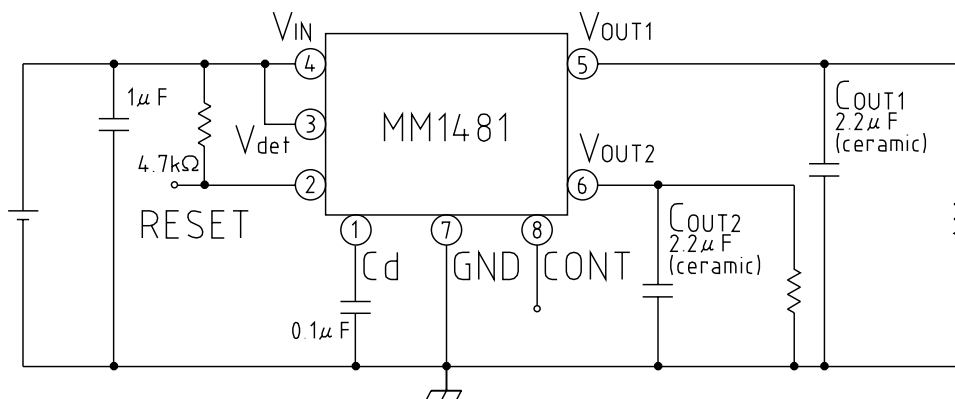

Note 1 : This regulator is not internally compensated and thus requires an external output-capacitor (Cout) for stability.

Note 2 : Please be careful with regard to set wiring and temperature-related capacitor changes that may cause oscillation.

Timing Chart

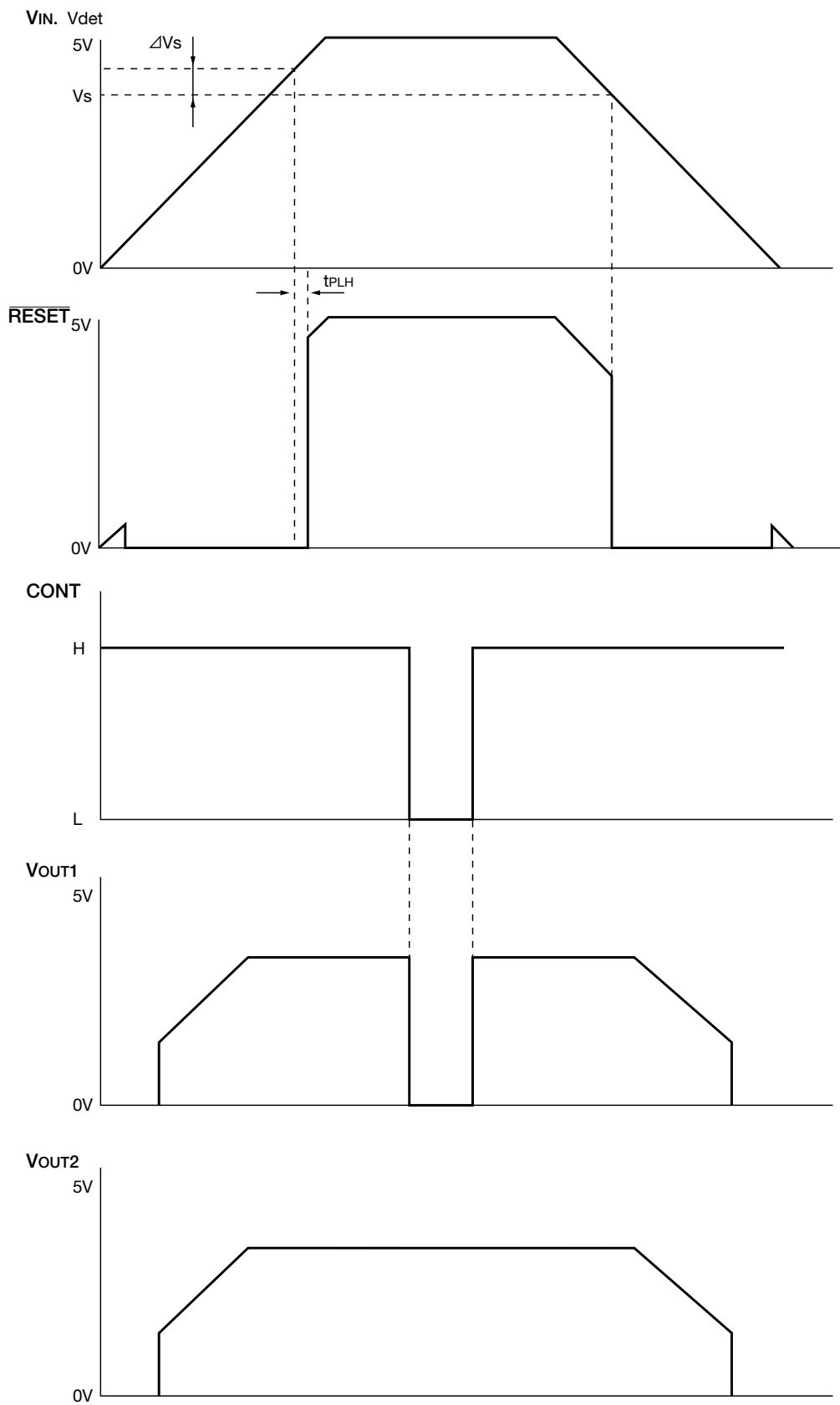

Characteristics

Detection voltage ($I_{OUT}=0mA$)

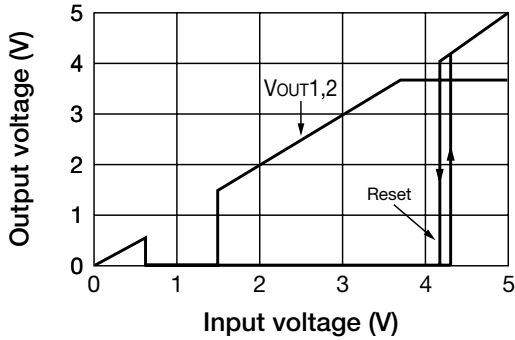

Output voltage vs temperature

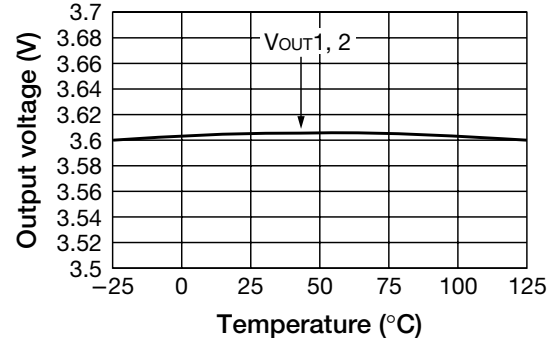

Line regulation

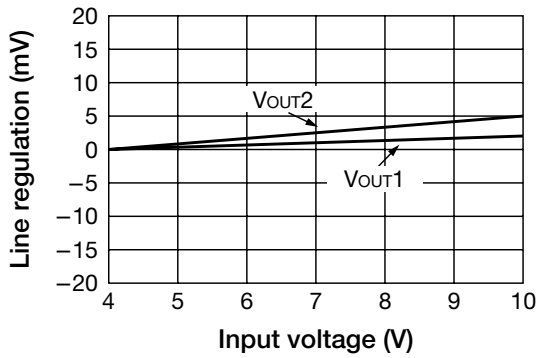

Load regulation

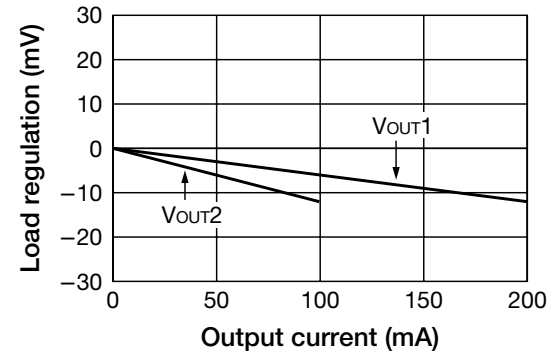

Ripple rejection

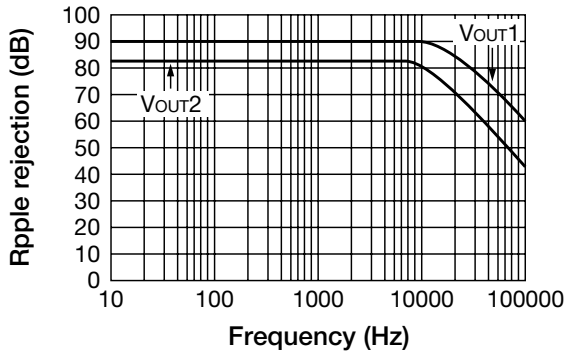

Detecting voltage vs temperature

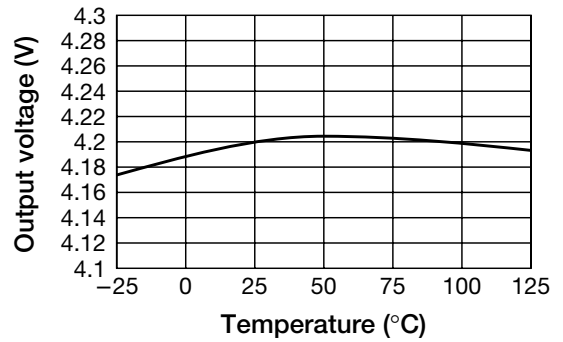

Allowable loss

