

## Features

- Low-power consumption
  - Active: 65mA  $I_{CC}$  at 35ns
  - Stand-by: 10  $\mu$ A (CMOS input/output)  
2  $\mu$ A (CMOS input/output, L version)
- 35/45/55/70/85/100 ns access time
- Equal access and cycle time
- Single +2.7V to 3.3V Power Supply
- Tri-state output
- Automatic power-down when deselected
- Multiple center power and ground pins for improved noise immunity
- Individual byte controls for both Read and Write cycles
- Available in 44 pin TSOP II / 48-fpBGA

## Functional Description

The V62C3162048L is a Low Power CMOS Static RAM organized as 131,072 words by 16 bits. Easy memory expansion is provided by an active LOW ( $\overline{CE}$ ) and ( $\overline{OE}$ ) pin.

This device has an automatic power-down mode feature when deselected. Separate Byte Enable controls ( $\overline{BLE}$  and  $\overline{BHE}$ ) allow individual bytes to be accessed.  $\overline{BLE}$  controls the lower bits I/O1 - I/O8.  $\overline{BHE}$  controls the upper bits I/O9 - I/O16.

Writing to these devices is performed by taking Chip Enable ( $\overline{CE}$ ) with Write Enable ( $\overline{WE}$ ) and Byte Enable ( $\overline{BLE}/\overline{BHE}$ ) LOW.

Reading from the device is performed by taking Chip Enable ( $\overline{CE}$ ) with Output Enable ( $\overline{OE}$ ) and Byte Enable ( $\overline{BLE}/\overline{BHE}$ ) LOW while Write Enable ( $\overline{WE}$ ) is held HIGH.

## Logic Block Diagram

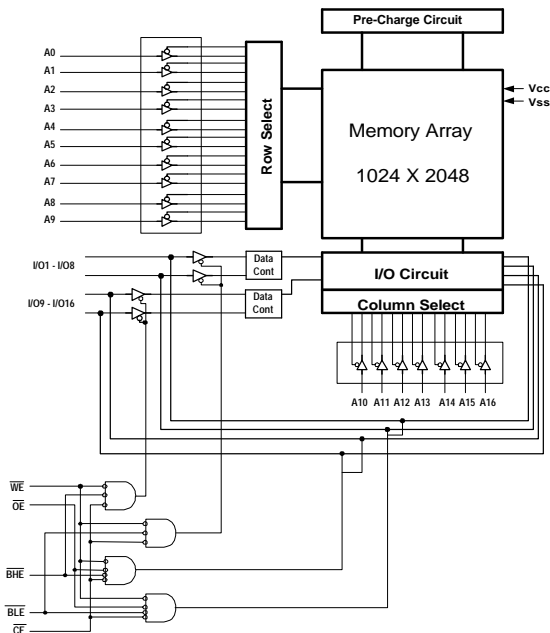

## TSOP II / 48-fpBGA

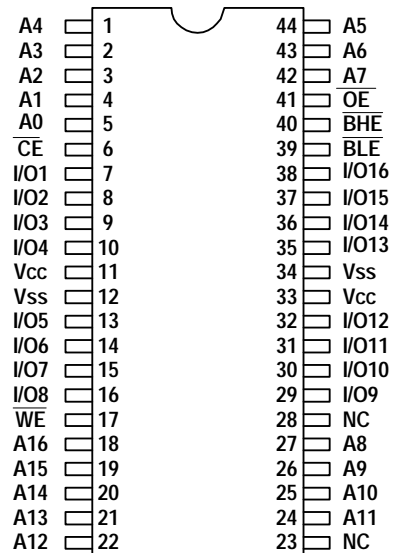

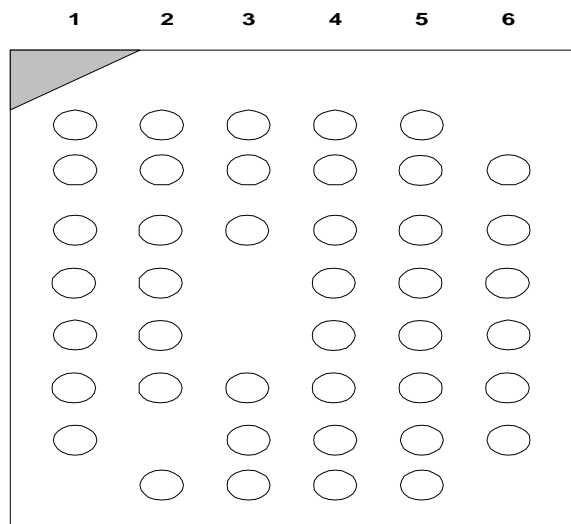
**MOSEL VITELIC V62C3162048L(L)B**

Top View

	1	2	3	4	5	6
A	$\overline{\text{BLE}}$	OE	A0	A1	A2	NC
B	I/O9	$\overline{\text{BHE}}$	A3	A4	$\overline{\text{CE}}$	I/O1
C	I/O10	I/O11	A5	A6	I/O2	I/O3
D	VSS	I/O12	NC	A7	I/O4	VCC
E	VCC	I/O13	NC	A16	I/O5	VSS
F	I/O15	I/O14	A14	A15	I/O6	I/O7
G	I/O16	NC	A12	A13	$\overline{\text{WE}}$	I/O8
H	NC	A8	A9	A10	A11	NC

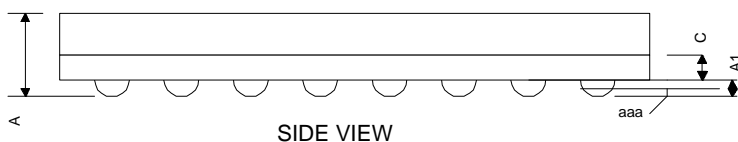
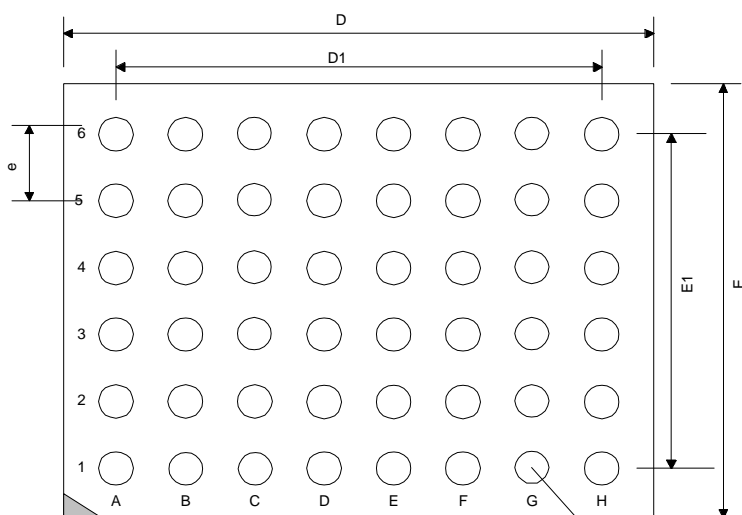
Note: NC means no Ball.

Top View
**48 Ball - 9x12 fpBGA (Ultra Low Power)**
**PACKAGE OUTLINE DWG.**

SIDE VIEW

BOTTOM VIEW

 b  
SOLDER BALL

SYMBOL	UNIT:MM
A	1.05+0.15
A1	0.25±0.05
b	0.35±.05
c	0.30(TYP)
D	12.00±0.10
D1	5.25
E	9.00±0.10
E1	3.75
e	0.75TYP
aaa	0.10

**Absolute Maximum Ratings \***

Parameter	Symbol	Minimum	Maximum	Unit
Voltage on Any Pin Relative to Gnd	Vt	-0.5	+4.6	V
Power Dissipation	PT	–	1.0	W
Storage Temperature (Plastic)	Tstg	-55	+150	°C
Temperature Under Bias	Tbias	-40	+85	°C

\* **Note:** Stresses greater than those listed above Absolute Maximum Ratings may cause permanent damage to the device. This is a stress rating only and function operation of the device at these or any other conditions outside those indicated in the operational sections of this specification is not implied. Exposure to absolute maximum rating conditions for extended periods may affect reliability.

**Truth Table**

CE	OE	WE	BLE	BHE	I/O1-I/O8	I/O9-I/O16	Power	Mode
H	X	X	X	X	High-Z	High-Z	Standby	Standby
L	L	H	L	H	Data Out	High-Z	Active	Low Byte Read
L	L	H	H	L	High-Z	Data Out	Active	High Byte Read
L	L	H	L	L	Data Out	Data Out	Active	Word Read
L	X	L	L	L	Data In	Data In	Active	Word Write
L	X	L	L	H	Data In	High-Z	Active	Low Byte Write
L	X	L	H	L	High-Z	Data In	Active	High Byte Write
L	H	H	X	X	High-Z	High-Z	Active	Output Disable
L	X	X	H	H	High-Z	High-Z	Active	Output Disable

\* **Key:** X = Don't Care, L = Low, H = High

**Recommended Operating Conditions** ( $T_A = 0^{\circ}\text{C}$  to  $+70^{\circ}\text{C}$  /  $-40^{\circ}\text{C}$  to  $85^{\circ}\text{C}^{**}$ )

Parameter	Symbol	Min	Typ	Max	Unit
Supply Voltage	V <sub>CC</sub>	2.7	3.0	3.3	V
	Gnd	0.0	0.0	0.0	V
Input Voltage	V <sub>IH</sub>	2.2	-	V <sub>CC</sub> + 0.2	V
	V <sub>IL</sub>	-0.5*	-	0.8	V

\* V<sub>IL</sub> min = -2.0V for pulse width less than t<sub>RC</sub>/2.

\*\* For Industrial Temperature

**DC Operating Characteristics** ( $V_{CC} = 2.7$  to  $3.3V$ ,  $Gnd = 0V$ ,  $T_A = 0^{\circ}C$  to  $+70^{\circ}C$  /  $-40^{\circ}C$  to  $85^{\circ}C$ )

Parameter	Sym	Test Conditions	-55		-70		-85		-100		Unit
			Min	Max	Min	Max	Min	Max	Min	Max	
Input Leakage Current	$ I_{L1} $	$V_{CC} = \text{Max}$ , $V_{in} = Gnd \text{ to } V_{CC}$	-	1	-	1	-	1	-	1	$\mu A$
Output Leakage Current	$ I_{LO} $	$\overline{CE} = V_{IH}$ or $V_{CC} = \text{Max}$ , $V_{OUT} = Gnd \text{ to } V_{CC}$	-	1	-	1	-	1	-	1	$\mu A$
Operating Power Supply Current	$I_{CC}$	$\overline{CE} = V_{IL}$ , $V_{IN} = V_{IH}$ or $V_{IL}$ , $I_{OUT} = 0$	-	5	-	5	-	5	-	5	$mA$
Average Operating Current	$I_{CC1}$	$I_{OUT} = 0mA$ , Min Cycle, 100% Duty	-	50	-	45	-	40	-	40	$mA$
	$I_{CC2}$	$\overline{CE} \leq 0.2V$ $I_{OUT} = 0mA$ , Cycle Time=1 $\mu s$ , Duty=100%	-	3	-	3	-	3	-	3	$mA$
Standby Power Supply Current (TTL Level)	$I_{SB}$	$\overline{CE} = V_{IH}$	-	0.5	-	0.5	-	0.5	-	0.5	$mA$
Standby Power Supply Current (CMOS Level)	$I_{SB1}$	$\overline{CE} \geq V_{CC} - 0.2V$	-	10	-	10	-	10	-	10	$\mu A$
		$V_{IN} \leq 0.2V$ or $V_{IN} \geq V_{CC} - 0.2V$ <b>L</b>	-	2	-	2	-	2	-	2	$\mu A$
Output Low Voltage	$V_{OL}$	$I_{OL} = 2 mA$	-	0.4	-	0.4	-	0.4	-	0.4	$V$
Output High Voltage	$V_{OH}$	$I_{OH} = -2 mA$	2.4	-	2.4	-	2.4	-	2.4	-	$V$

**Capacitance** ( $f = 1MHz$ ,  $T_A = 25^{\circ}C$ )

Parameter*	Symbol	Test Condition	Max	Unit
Input Capacitance	$C_{in}$	$V_{in} = 0V$	7	$\mu F$
I/O Capacitance	$C_{I/O}$	$V_{in} = V_{out} = 0V$	8	$\mu F$

\* This parameter is guaranteed by device characterization and is not production tested.

**AC Test Conditions**

Input Pulse Level      0.6V to 2.2V  
 Input Rise and Fall Time      5ns  
 Input and Output Timing Reference Level      1.4V

Output Load Condition  
 55ns/70ns/85ns       $C_L = 30pf + 1TTL \text{ Load}$   
 Load for 100ns       $C_L = 100pf + 1TTL \text{ Load}$

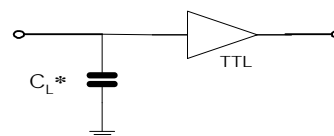

Figure A. \* Including Scope and Jig Capacitance

**DC Operating Characteristics** ( $V_{CC} = 2.7$  to  $3.3V$ ,  $Gnd = 0V$ ,  $T_A = 0^{\circ}C$  to  $+70^{\circ}C$  /  $-40^{\circ}C$  to  $85^{\circ}C$ )

Parameter	Sym	Test Conditions	-35		-45		Unit
			Min	Max	Min	Max	
Input Leakage Current	$ I_{LI} $	$V_{CC} = \text{Max}$ , $V_{in} = \text{Gnd to } V_{CC}$	-	1	-	1	$\mu A$
Output Leakage Current	$ I_{LO} $	$\overline{CE} = V_{IH}$ or $V_{CC} = \text{Max}$ , $V_{OUT} = \text{Gnd to } V_{CC}$	-	1	-	1	$\mu A$
Operating Power Supply Current	$I_{CC}$	$\overline{CE} = V_{IL}$ , $V_{IN} = V_{IH}$ or $V_{IL}$ , $I_{OUT} = 0$	-	5	-	5	mA
Average Operating Current	$I_{CC1}$	$I_{OUT} = 0\text{mA}$ , Min Cycle, 100% Duty	-	65	-	60	mA
	$I_{CC2}$	$\overline{CE} \leq 0.2V$ $I_{OUT} = 0\text{mA}$ , Cycle Time=1 $\mu s$ , Duty=100%	-	3	-	3	mA
Standby Power Supply Current (TTL Level)	$I_{SB}$	$\overline{CE} = V_{IH}$	-	0.5	-	0.5	mA
Standby Power Supply Current (CMOS Level)	$I_{SB1}$	$\overline{CE} \geq V_{CC} - 0.2V$	-	10	-	10	$\mu A$
		$V_{IN} \leq 0.2V$ or $V_{IN} \geq V_{CC} - 0.2V$	<b>L</b>	2	-	2	$\mu A$
Output Low Voltage	$V_{OL}$	$I_{OL} = 2\text{ mA}$	-	0.4	-	0.4	V
Output High Voltage	$V_{OH}$	$I_{OH} = -2\text{ mA}$	2.4	-	2.4	-	V

**Read Cycle <sup>(9)</sup>** ( $V_{cc} = 2.7$  to  $3.3V$ ,  $Gnd = 0V$ ,  $T_A = 0^{\circ}C$  to  $+70^{\circ}C$  /  $-40^{\circ}C$  to  $+85^{\circ}C$ )

Parameter	Sym	-55		-70		-85		-100		Unit	Note
		Min	Max	Min	Max	Min	Max	Min	Max		
Read Cycle Time	$t_{RC}$	55	-	70	-	85	-	100	-	ns	
Address Access Time	$t_{AA}$	-	55	-	70	-	85	-	100	ns	
Chip Enable Access Time	$t_{ACE}$	-	55	-	70	-	85	-	100	ns	
Output Enable Access Time	$t_{OE}$	-	35	-	40	-	40	-	50	ns	
Output Hold from Address Change	$t_{OH}$	10	-	10	-	10	-	10	-	ns	
Chip Enable to Output in Low-Z	$t_{LZ}$	10	-	10	-	10	-	10	-	ns	4,5
Chip Disable to Output in High-Z	$t_{HZ}$	-	25	-	30	-	35	-	40	ns	3,4,5
Output Enable to Output in Low-Z	$t_{OLZ}$	5	-	5	-	5	-	5	-	ns	
Output Disable to Output in High-Z	$t_{OHZ}$	-	25	-	25	-	30	-	35	ns	
$\overline{BLE}$ , $\overline{BHE}$ Enable to Output in Low-Z	$t_{BLZ}$	5	-	5	-	5	-	5	-	ns	4,5
$\overline{BLE}$ , $\overline{BHE}$ Disable to Output in High-Z	$t_{BHZ}$	-	25	-	25	-	30	-	35	ns	3,4,5
$\overline{BLE}$ , $\overline{BHE}$ Access Time	$t_{BA}$	-	35	-	40	-	40	-	50	ns	

**Write Cycle <sup>(11)</sup>** ( $V_{cc} = 2.7$  to  $3.3V$ ,  $Gnd = 0V$ ,  $T_A = 0^{\circ}C$  to  $+70^{\circ}C$  /  $-40^{\circ}C$  to  $+85^{\circ}C$ )

Parameter	Symbol	-55		-70		-85		-100		Unit	Note
		Min	Max	Min	Max	Min	Max	Min	Max		
Write Cycle Time	$t_{WC}$	55	-	70	-	85	-	100	-	ns	
Chip Enable to Write End	$t_{CW}$	50	-	60	-	70	-	80	-	ns	
Address Setup to Write End	$t_{AW}$	50	-	60	-	70	-	80	-	ns	
Address Setup Time	$t_{AS}$	0	-	0	-	0	-	0	-	ns	
Write Pulse Width	$t_{WP}$	45	-	50	-	60	-	70	-	ns	
Write Recovery Time	$t_{WR}$	0	-	0	-	0	-	0	-	ns	
Data Valid to Write End	$t_{DW}$	25	-	30	-	35	-	40	-	ns	
Data Hold Time	$t_{DH}$	0	-	0	-	0	-	0	-	ns	
Write Enable to Output in High-Z	$t_{WHZ}$	-	25	-	30	-	35	-	40	ns	
Output Active from Write End	$t_{OW}$	5	-	5	-	5	-	5	-	ns	
$\overline{BLE}$ , $\overline{BHE}$ Setup to Write End	$t_{BW}$	50	-	60	-	70	-	80	-	ns	

**Read Cycle <sup>(9)</sup>** ( $V_{cc} = 2.7$  to  $3.3V$ ,  $Gnd = 0V$ ,  $T_A = 0^{\circ}C$  to  $+70^{\circ}C$  /  $-40^{\circ}C$  to  $+85^{\circ}C$ )

Parameter	Sym	-35		-45		Unit	Note
		Min	Max	Min	Max		
Read Cycle Time	$t_{RC}$	35	-	45	-	ns	
Address Access Time	$t_{AA}$	-	35	-	45	ns	
Chip Enable Access Time	$t_{ACE}$	-	35	-	45	ns	
Output Enable Access Time	$t_{OE}$	-	20	-	25	ns	
Output Hold from Address Change	$t_{OH}$	5	-	5	-	ns	
Chip Enable to Output in Low-Z	$t_{LZ}$	5	-	5	-	ns	4,5
Chip Disable to Output in High-Z	$t_{HZ}$	-	15	-	20	ns	3,4,5
Output Enable to Output in Low-Z	$t_{OLZ}$	5	-	5	-	ns	
Output Disable to Output in High-Z	$t_{OHZ}$	-	15	-	20	ns	
$\overline{BLE}$ , $\overline{BHE}$ Enable to Output in Low-Z	$t_{BLZ}$	5	-	5	-	ns	4,5
$\overline{BLE}$ , $\overline{BHE}$ Disable to Output in High-Z	$t_{BHZ}$	-	15	-	20	ns	3,4,5
$\overline{BLE}$ , $\overline{BHE}$ Access Time	$t_{BA}$	-	20	-	25	ns	

**Write Cycle <sup>(11)</sup>** ( $V_{cc} = 2.7$  to  $3.3V$ ,  $Gnd = 0V$ ,  $T_A = 0^{\circ}C$  to  $+70^{\circ}C$  /  $-40^{\circ}C$  to  $+85^{\circ}C$ )

Parameter	Sym	-35		-45		Unit	Note
		Min	Max	Min	Max		
Write Cycle Time	$t_{WC}$	35	-	45	-	ns	
Chip Enable to Write End	$t_{CW}$	30	-	35	-	ns	
Address Setup to Write End	$t_{AW}$	30	-	35	-	ns	
Address Setup Time	$t_{AS}$	0	-	0	-	ns	
Write Pulse Width	$t_{WP}$	30	-	35	-	ns	
Write Recovery Time	$t_{WR}$	0	-	0	-	ns	
Data Valid to Write End	$t_{DW}$	20	-	25	-	ns	
Data Hold Time	$t_{DH}$	0	-	0	-	ns	
Write Enable to Output in High-Z	$t_{WHZ}$	-	25	-	25	ns	
Output Active from Write End	$t_{OW}$	5	-	5	-	ns	
$\overline{BLE}$ , $\overline{BHE}$ Setup to Write End	$t_{BW}$	30	-	35	-	ns	



Timing Waveform of Read Cycle 1 (Address Controlled)

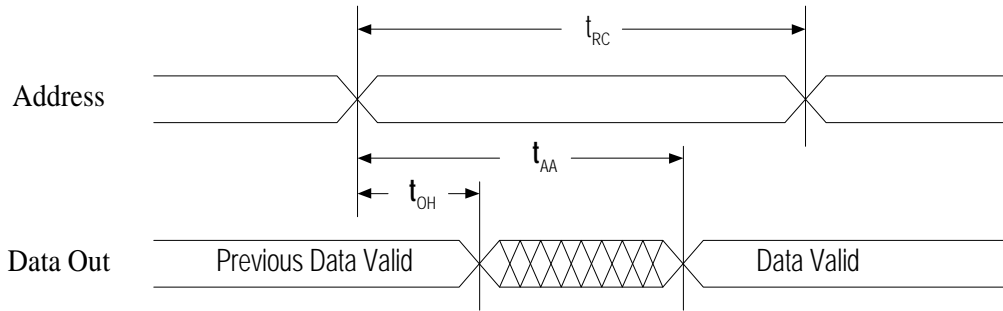

Timing Waveform of Read Cycle 2

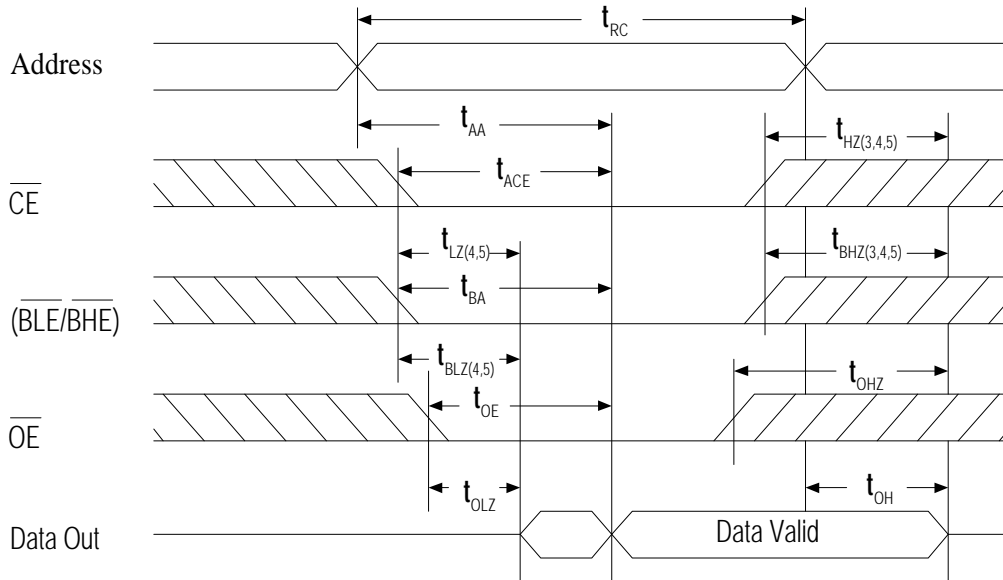

Notes (Read Cycle)

1. WE are high for read cycle.
2. All read cycle timing is referenced from the last valid address to the first transition address.
3.  $t_{HZ}$  and  $t_{OHZ}$  are defined as the time at which the outputs achieve the open circuit condition referenced to  $V_{OH}$  or  $V_{OL}$  levels.
4. At any given temperature and voltage condition  $t_{HZ}$  (max.) is less than  $t_{LZ}$  (min.) both for a given device and from device to device.
5. Transition is measured  $\pm 200mV$  from steady state voltage with load. This parameter is sampled and not 100% tested.
6. Device is continuously selected with  $\overline{CE} = V_{IL}$ .
7. Address valid prior to coincident with  $\overline{CE}$  transition Low.
8. For common I/O applications, minimization or elimination of bus contention conditions is necessary during read and write cycle.
9. For test conditions, see AC Test Condition, Figure A.

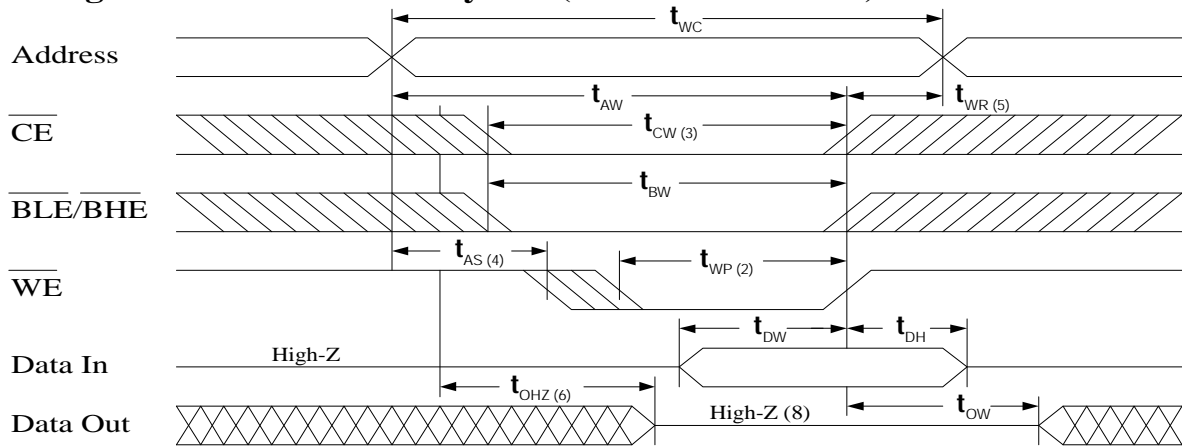
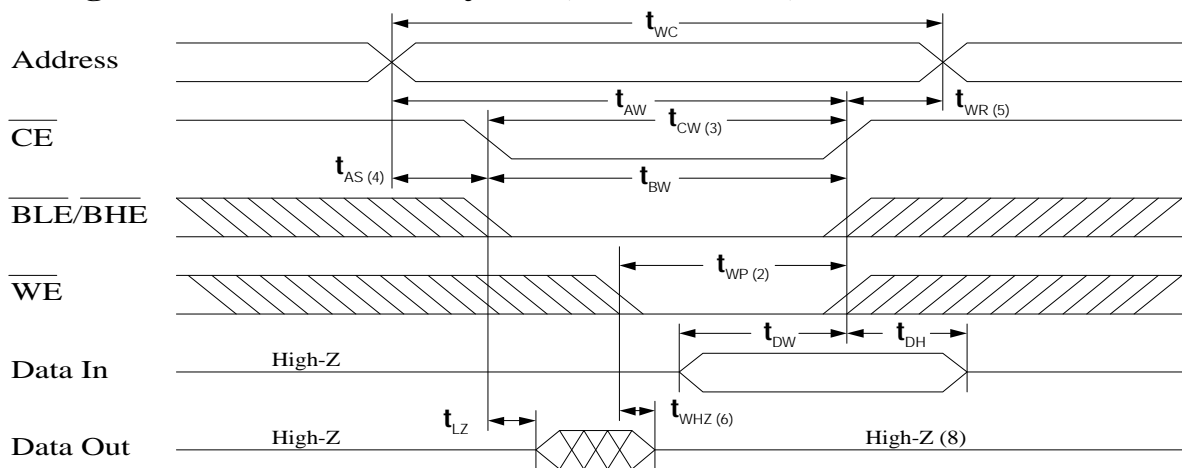
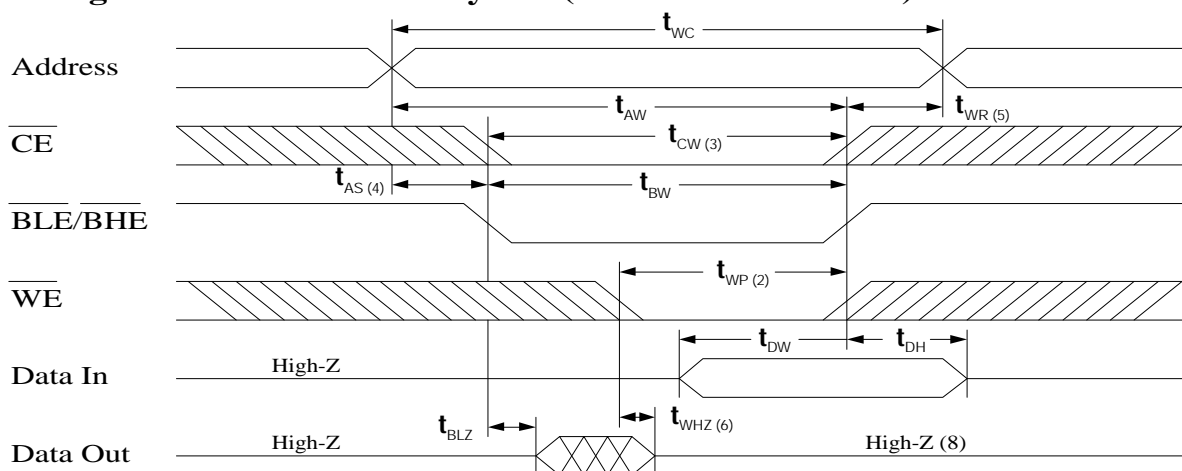

**Timing Waveform of Write Cycle 1 (Address Controlled)**

**Timing Waveform of Write Cycle 2 (CE Controlled)**

**Timing Waveform of Write Cycle 3 (BLE/BHE Controlled)**

---

**Notes (Write Cycle)**

1. All write timing is referenced from the last valid address to the first transition address.
2. A write occurs during the overlap of a low  $\overline{CE}$  and  $\overline{WE}$ . A write begins at the latest transition among  $\overline{CE}$  and  $\overline{WE}$  going low: A write ends at the earliest transition among  $\overline{CE}$  going high and  $\overline{WE}$  going high.  $t_{WP}$  is measured from the beginning of write to the end of write.
3.  $t_{CW}$  is measured from the later of  $\overline{CE}$  going low to end of write.
4.  $t_{AS}$  is measured from the address valid to the beginning of write.
5.  $t_{WR}$  is measured from the end of write to the address change.
6. If  $\overline{OE}$ ,  $\overline{CE}$  and  $\overline{WE}$  are in the Read Mode during this period, the I/O pins are in the output Low-Z state. Inputs of opposite phase of the output must not be applied because bus contention can occur.
7. For common I/O applications, minimization or elimination of bus contention conditions is necessary during read and write cycle.
8. If  $\overline{CE}$  goes low simultaneously with  $\overline{WE}$  going low or after  $\overline{WE}$  going low, the outputs remain high impedance state.
9. DOUT is the read data of the new address.
10. When  $\overline{CE}$  is low: I/O pins are in the outputs state. The input signals in the opposite phase leading to the output should not be applied.
11. For test conditions, see *AC Test Condition*, Figure A.

**Data Retention Characteristics (L Version Only)<sup>(1)</sup>**

Parameter	Symbol	Test Condition	Min	Max	Unit
V <sub>CC</sub> for Data Retention	V <sub>DR</sub>	$\overline{CE} \geq V_{CC} - 0.2V$	2.0	-	V
Data Retention Current	I <sub>CCDR</sub>		-	1	μA
Chip Deselect to Data Retention Time	t <sub>CDR</sub>	V <sub>IN</sub> ≥ V <sub>CC</sub> - 0.2V or	0	-	ns
Operation Recovery Time <sup>(2)</sup>	t <sub>R</sub>	V <sub>IN</sub> ≤ 0.2V	t <sub>RC</sub>	-	ns

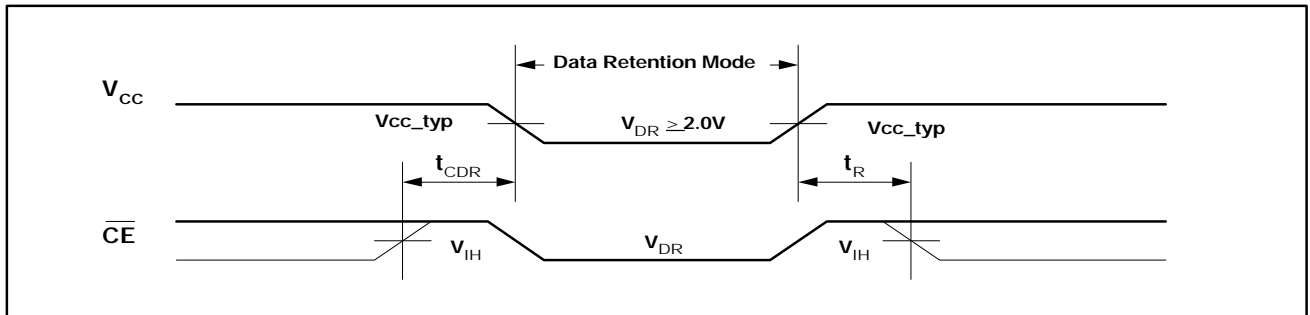
**Data Retention Waveform (L Version Only) (T<sub>A</sub> = 0<sup>0</sup>C to +70<sup>0</sup>C / -40<sup>0</sup>C to +85<sup>0</sup>C)**

**Notes (Write Cycle)**

1. L-version includes this feature.
2. This Parameter is samples and not 100% tested.
3. For test conditions, see *AC Test Condition*, Figure A.
4. This parameter is tested with CL = 5pF as shown in Figure B. Transition is measured ± 500mV from steady-state voltage.
5. This parameter is guaranteed, but is not tested.
6.  $\overline{WE}$  is High for read cycle.
7.  $\overline{CE}$  and  $\overline{OE}$  are LOW for read cycle.
8. Address valid prior to or coincident with  $\overline{CE}$  transition LOW.
9. All read cycle timings are referenced from the last valid address to the first transition address.
10.  $\overline{CE}$  or  $\overline{WE}$  must be HIGH during address transition.
11. All write cycle timings are referenced from the last valid address to the first transition address.

**Ordering Information**

<b>Device Type*</b>	<b>Speed</b>	<b>Package</b>
V62C3162048L-35T	35 ns	44-pin TSOP Type 2
V62C3162048L-45T	45 ns	
V62C3162048L-55T	55 ns	
V62C3162048L-70T	70 ns	
V62C3162048L-85T	85 ns	
V62C3162048L-100T	100 ns	
V62C3162048LL-35T	35 ns	
V62C3162048LL-45T	45 ns	
V62C3162048LL-55T	55 ns	
V62C3162048LL-70T	70 ns	
V62C3162048LL-85T	85 ns	
V62C3162048LL-100T	100 ns	
V62C3162048L(L)-35B	35 ns	48-fpBGA
V62C3162048L(L)-45B	45 ns	
V62C3162048L(L)-55B	55 ns	
V62C3162048L(L)-70B	70 ns	
V62C3162048L(L)-85B	85 ns	
V62C3162048L(L)-100B	100 ns	

\* For Industrial temperature tested devices, an "I" designator will be added to the end of the device number.

**U.S.A.**

3910 NORTH FIRST STREET  
SAN JOSE, CA 95134  
PHONE: 408-433-6000  
FAX: 408-433-0952

**TAIWAN**

7F, NO. 102  
MIN-CHUAN E. ROAD, SEC. 3  
TAIPEI  
PHONE: 886-2-2545-1213  
FAX: 886-2-2545-1209

NO 19 LI HSIN ROAD  
SCIENCE BASED IND. PARK  
HSIN CHU, TAIWAN, R.O.C.  
PHONE: 886-3-579-5888  
FAX: 886-3-566-5888

**SINGAPORE**

10 ANSON ROAD #23-13  
INTERNATIONAL PLAZA  
SINGAPORE 079903  
PHONE: 65-3231801  
FAX: 65-3237013

**JAPAN**

ONZE 1852 BUILDING 6F  
2-14-6 SHINTOMI, CHUO-KU  
TOKYO 104-0041  
PHONE: 03-3537-1400  
FAX: 03-3537-1402

**UK & IRELAND**

SUITE 50, GROVEWOOD  
BUSINESS CENTRE  
STRATHCLYDE BUSINESS  
PARK  
BELLSHILL, LANARKSHIRE,  
SCOTLAND, ML4 3NQ  
PHONE: 44-1698-748515  
FAX: 44-1698-748516

**GERMANY  
(CONTINENTAL  
EUROPE & ISRAEL)**

BENZSTRASSE 32  
71083 HERRENBERG  
GERMANY  
PHONE: +49 7032 2796-0  
FAX: +49 7032 2796 22

**U.S. SALES OFFICES****NORTHWESTERN**

3910 NORTH FIRST STREET  
SAN JOSE, CA 95134  
PHONE: 408-433-6000  
FAX: 408-433-0952

**SOUTHWESTERN**

302 N. EL CAMINO REAL #200  
SAN CLEMENTE, CA 92672  
PHONE: 949-361-7873  
FAX: 949-361-7807

**CENTRAL,  
NORTHEASTERN &  
SOUTHEASTERN**

604 FIELDWOOD CIRCLE  
RICHARDSON, TX 75081  
PHONE: 214-826-6176  
FAX: 214-828-9754

---

The information in this document is subject to change without notice.

MOSEL VITELIC makes no commitment to update or keep current the information contained in this document. No part of this document may be copied or reproduced in any form or by any means without the prior written consent of MOSEL-VITELIC.

MOSEL VITELIC subjects its products to normal quality control sampling techniques which are intended to provide an assurance of high quality products suitable for usual commercial applications. MOSEL VITELIC does not do testing appropriate to provide 100% product quality assurance and does not assume any liability for consequential or incidental arising from any use of its products. If such products are to be used in applications in which personal injury might occur from failure, purchaser must do its own quality assurance testing appropriate to such applications.