

MOSEL VITELIC

V53C317405A
4M X 4 EDO PAGE MODE
CMOS DYNAMIC RAM

V53C317405A	50	60
Max. $\overline{\text{RAS}}$ Access Time, (t_{RAC})	50 ns	60 ns
Max. Column Address Access Time, (t_{CAA})	25 ns	30 ns
Min. Extended Data Out Page Mode Cycle Time, (t_{PC})	20 ns	25 ns
Min. Read/Write Cycle Time, (t_{RC})	84 ns	104 ns

Features

- 4M x 4-bit organization
- EDO Page Mode for a sustained data rate of 50 MHz
- $\overline{\text{RAS}}$ access time: 50, 60, 70 ns
- Low power dissipation
- Read-Modify-Write, $\overline{\text{RAS}}$ -Only Refresh, $\overline{\text{CAS}}$ -Before- $\overline{\text{RAS}}$ Refresh, Hidden Refresh
- Refresh Interval: 2048 cycles/32 ms
- Available in 24/26-pin 300 mil SOJ, and 24/26-pin 300 mil TSOP-II
- Single +3.3 V $\pm 10\%$ Power Supply
- TTL Interface

Description

The V53C317405A is a 4,194,304 x 4 bit high-performance CMOS dynamic random access memory. The V53C317405A offers Page mode operation with Extended Data Output. The V53C317405A has a symmetric address, 11-bit row and 11-bit column.

All inputs are TTL compatible. EDO Page Mode operation allows random access up to 2048 x 4 bits, within a page, with cycle times as short as 20ns.

These features make the V53C317405A ideally suited for a wide variety of high performance computer systems and peripheral applications.

Device Usage Chart

Operating Temperature Range	Package Outline		Access Time (ns)		Power	Temperature Mark
	K	T	50	60	Std.	
0°C to 70°C	•	•	•	•	•	Blank

**24/26 Pin Plastic SOJ /TSOP-II
PIN CONFIGURATION
Top View**

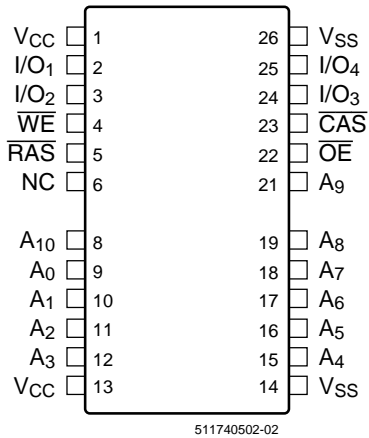

Pin Names

A ₀ -A ₁₀	Row, Column Address Inputs
$\overline{\text{RAS}}$	Row Address Strobe
$\overline{\text{CAS}}$	Column Address Strobe
$\overline{\text{WE}}$	Write Enable
$\overline{\text{OE}}$	Output Enable
I/O ₁ -I/O ₄	Data Input, Output
V _{CC}	+3.3V Supply
V _{SS}	0V Supply
NC	No Connect

Description	Pkg.	Pin Count
SOJ	K	24/26
TSOP-II	T	24/26

Absolute Maximum Ratings*

Operating temperature range0 to 70 °C
 Storage temperature range -55 to 150 °C
 Input/output voltage -0.5 to min (V_{CC}+0.5, 4.6) V
 Power supply voltage-1.0V to 4.6V
 Power dissipation 0.5 W
 Data out current (short circuit) 50 mA

*Note: Operation above Absolute Maximum Ratings can adversely affect device reliability.

Capacitance*

T_A = 25°C, V_{CC} = 3.3 V ± 10%, V_{SS} = 0 V, f = 1 MHz

Symbol	Parameter	Min.	Max.	Unit
C _{IN1}	Address Input	—	5	pF
C _{IN2}	RAS, CAS, WE, OE	—	7	pF
C _{OUT}	Data Input/Output	—	7	pF

*Note: Capacitance is sampled and not 100% tested.

Block Diagram

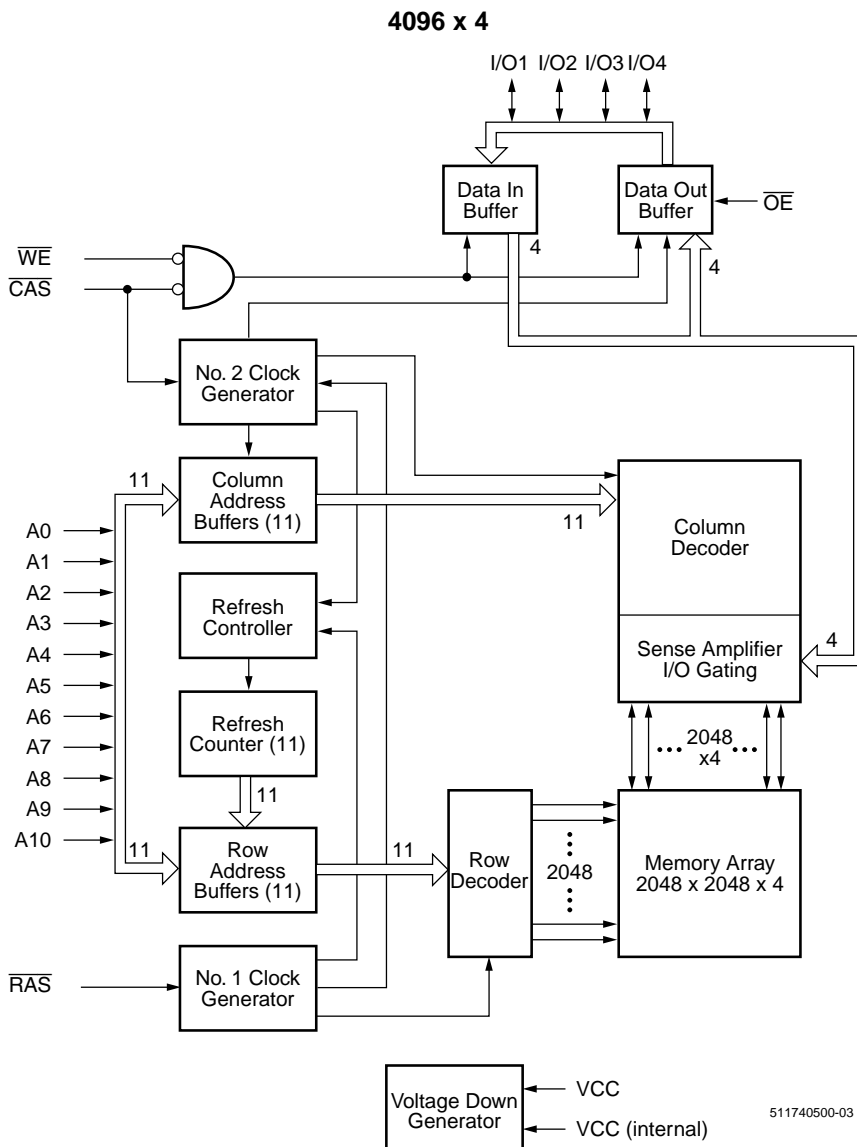

DC and Operating Characteristics (1-2)

$T_A = 0^\circ\text{C}$ to 70°C , $V_{CC} = 3.3\text{ V} \pm 10\%$, $V_{SS} = 0\text{ V}$, $t_T = 2\text{ ns}$, unless otherwise specified.

Symbol	Parameter	Access Time	V53C317405A			Unit	Test Conditions	Notes
			Min.	Typ.	Max.			
I_{LI}	Input Leakage Current (any input pin)		-10		10	μA	$V_{SS} \leq V_{IN} \leq V_{CC} + 0.5\text{V}$	1
I_{LO}	Output Leakage Current (for High-Z State)		-10		10	μA	$V_{SS} \leq V_{OUT} \leq V_{CC} + 0.5\text{V}$ RAS, CAS at V_{IH} other input $\geq V_{SS}$	1
I_{CC1}	V_{CC} Supply Current, Operating	50			120	mA	$t_{RC} = t_{RC}(\text{min.})$	2, 3, 4
		60			110			
I_{CC2}	V_{CC} Supply Current, TTL Standby				2	mA	RAS, CAS at V_{IH} other inputs $\geq V_{SS}$	
I_{CC3}	V_{CC} Supply Current, RAS-Only Refresh	50			120	mA	$t_{RC} = t_{RC}(\text{min.})$	2, 4
		60			110			
I_{CC4}	V_{CC} Supply Current, EDO Page Mode Operation	50			70	mA	Minimum Cycle	2, 3, 4
		60			55			
I_{CC5}	V_{CC} Supply Current, during CAS-before-RAS Refresh	50			120	mA		2, 4
		60			110			
I_{CC6}	V_{CC} Supply Current, CMOS Standby				1.0	mA	$\overline{\text{RAS}} \geq V_{CC} - 0.2\text{ V}$, $\overline{\text{CAS}} \geq V_{CC} - 0.2\text{ V}$ other input $\geq V_{SS}$	1
V_{CC}	Power Supply Voltage		3.0	3.3	3.6	V		
V_{IL}	Input Low Voltage		-0.5		0.8	V		1
V_{IH}	Input High Voltage		2.0		$V_{CC}+0.5$	V		1
V_{OL}	Output Low Voltage				0.4	V	$I_{OL} = 2\text{ mA}$	1
V_{OH}	Output High Voltage		2.4		—	V	$I_{OH} = -2\text{ mA}$	1

AC Characteristics^(5, 6) $T_A = 0$ to $70\text{ }^\circ\text{C}$, $V_{CC} = 3.3\text{ V} \pm 10\%$, $t_T = 2\text{ ns}$

#	Symbol	Parameter	-50		-60		Unit	Note
			min.	max.	min.	max.		
Common Parameters								
1	t_{RC}	Random read or write cycle time	84	–	104	–	ns	
2	t_{RP}	\overline{RAS} precharge time	30	–	40	–	ns	
3	t_{RAS}	\overline{RAS} pulse width	50	10k	60	10k	ns	
4	t_{CAS}	\overline{CAS} pulse width	8	10k	10	10k	ns	
5	t_{ASR}	Row address setup time	0	–	0	–	ns	
6	t_{RAH}	Row address hold time	8	–	10	–	ns	
7	t_{ASC}	Column address setup time	0	–	0	–	ns	
8	t_{CAH}	Column address hold time	8	–	10	–	ns	
9	t_{RCD}	\overline{RAS} to \overline{CAS} delay time	12	37	14	45	ns	
10	t_{RAD}	\overline{RAS} to column address delay	10	25	12	30	ns	
11	t_{RSH}	\overline{RAS} hold time	13		15	–	ns	
12	t_{CSH}	\overline{CAS} hold time	40		50	–	ns	
13	t_{CRP}	\overline{CAS} to \overline{RAS} precharge time	5	–	5	–	ns	
14	t_T	Transition time (rise and fall)	1	50	1	50	ns	7
15	t_{REF}	Refresh period	–	32	–	32	ms	
Read Cycle								
16	t_{RAC}	Access time from \overline{RAS}	–	50	–	60	ns	8, 9
17	t_{CAC}	Access time from \overline{CAS}	–	13	–	15	ns	8, 9
18	t_{CAA}	Access time from column address	–	25	–	30	ns	8,10
19	t_{OEA}	\overline{OE} access time	–	13	–	15	ns	
20	t_{RAL}	Column address to \overline{RAS} lead time	25	–	30	–	ns	
21	t_{RCS}	Read command setup time	0	–	0	–	ns	
22	t_{RCH}	Read command hold time	0	–	0	–	ns	11
23	t_{RRH}	Read command hold time referenced to \overline{RAS}	0	–	0	–	ns	11
24	t_{CLZ}	\overline{CAS} to output in low-Z	0	–	0	–	ns	8
25	t_{OFF}	Output buffer turn-off delay	0	13	0	15	ns	12
26	t_{OEZ}	Output turn-off delay from \overline{OE}	0	13	0	15	ns	12
27	t_{DZC}	Data to \overline{CAS} low delay	0	–	0	–	ns	13
28	t_{DZO}	Data to \overline{OE} low delay	0	–	0	–	ns	13
29	t_{CDD}	\overline{CAS} high to data delay	10	–	13	–	ns	14
30	t_{ODD}	\overline{OE} high to data delay	10	–	13	–	ns	14

AC Characteristics^(5, 6) $T_A = 0$ to $70\text{ }^\circ\text{C}$, $V_{CC} = 3.3\text{ V} \pm 10\%$, $t_T = 2\text{ ns}$

#	Symbol	Parameter	-50		-60		Unit	Note
			min.	max.	min.	max.		
Write Cycle								
31	t_{WCH}	Write command hold time	8	–	10	–	ns	
32	t_{WCP}	Write command pulse width	8	–	10	–	ns	
33	t_{WCS}	Write command setup time	0	–	0	–	ns	15
34	t_{RWL}	Write command to \overline{RAS} lead time	8	–	10	–	ns	
35	t_{CWL}	Write command to \overline{CAS} lead time	8	–	10	–	ns	
36	t_{DS}	Data setup time	0	–	0	–	ns	16
37	t_{DH}	Data hold time	8	–	10	–	ns	16
Read-modify-Write Cycle								
38	t_{RWC}	Read-write cycle time	113	–	138	–	ns	
39	t_{RWD}	\overline{RAS} to \overline{WE} delay time	64	–	77	–	ns	15
40	t_{CWD}	\overline{CAS} to \overline{WE} delay time	27	–	32	–	ns	15
41	t_{AWD}	Column address to \overline{WE} delay time	39	–	47	–	ns	15
42	t_{OEH}	\overline{OE} command hold time	10	–	13	–	ns	
EDO Page Mode Cycle								
43	t_{PC}	EDO page mode cycle time	20	–	25	–	ns	
44	t_{CP}	\overline{CAS} precharge time	8	–	10	–	ns	
45	t_{CPA}	Access time from \overline{CAS} precharge	–	27	–	32	ns	7
46	t_{COH}	Output data hold time	5	–	5	–	ns	
47	t_{RASP}	\overline{RAS} pulse width in EDO mode	50	200k	60	200k	ns	
48	t_{RHPC}	\overline{CAS} precharge to \overline{RAS} Delay	27	–	32	–	ns	
49	t_{OES}	\overline{OE} setup time prior to \overline{CAS}	5	–	5	–	ns	
EDO Page Mode Read-modify-Write Cycle								
50	t_{PRWC}	EDO page mode read-write cycle time	58	–	68	–	ns	
51	t_{CPWD}	\overline{CAS} precharge to \overline{WE}	41	–	49	–	ns	
CAS-before-RAS Refresh Cycle								
52	t_{CSR}	\overline{CAS} setup time	10	–	10	–	ns	
53	t_{CHR}	\overline{CAS} hold time	10	–	10	–	ns	
54	t_{RPC}	\overline{RAS} to \overline{CAS} precharge time	5	–	5	–	ns	
55	t_{WRP}	Write to \overline{RAS} precharge time	10	–	10	–	ns	
56	t_{WRH}	Write hold time referenced to \overline{RAS}	10	–	10	–	ns	

AC Characteristics^(5, 6)

$T_A = 0$ to 70 °C, $V_{CC} = 3.3$ V \pm 10 %, $t_T = 2$ ns

#	Symbol	Parameter	-50		-60		Unit	Note
			min.	max.	min.	max.		
CAS-before-RAS Counter Test Cycle								
57	t_{CPT}	\overline{CAS} precharge time	35	–	40	–	ns	
Test Mode								
61	t_{WTS}	Write command setup time	10	–	10	–	ns	
62	t_{WTH}	Write command hold time	10	–	10	–	ns	
63	t_{CHRT}	CAS hold time	30	–	30	–	ns	
64	t_{RAHT}	\overline{RAS} hold time in test mode	30	–	30	–	ns	

Notes:

- 1) All voltages are referenced to V_{SS} .
- 2) I_{CC1} , I_{CC3} , I_{CC4} and I_{CC5} depend on cycle rate.
- 3) I_{CC1} and I_{CC4} depend on output loading. Specified values are obtained with the output open.
- 4) Address can be changed once or less while $\overline{RAS} = V_{IL}$. In case of I_{CC4} it can be changed once or less during a EDO page mode cycle
- 5) An initial pause of 200 μs is required after power-up followed by 8 \overline{RAS} cycles of which at least one cycle has to be a refresh cycle, before proper device operation is achieved. In case of using the internal refresh counter, a minimum of 8 \overline{CAS} -before- \overline{RAS} initialization cycles instead of 8 \overline{RAS} cycles are required.
- 6) AC measurements assume $t_T = 2$ ns.
- 7) $V_{IH(min)}$ and $V_{IL(max)}$ are reference levels for measuring timing of input signals. Transition times are also measured between V_{IH} and V_{IL} .
- 8) Measured with the specified current load and 100 pF at $V_{OL} = 0.8$ V and $V_{OH} = 2.0$ V. Access time is determined by the latter of t_{RAC} , t_{CAC} , t_{CAA} , t_{CPA} , t_{OEA} . t_{CAC} is measured from tristate.
- 9) Operation within the $t_{RCD(max)}$ limit ensures that $t_{RAC(max)}$ can be met. $t_{RCD(max)}$ is specified as a reference point only. If t_{RCD} is greater than the specified $t_{RCD(max)}$ limit, then access time is controlled by t_{CAC} .
- 10) Operation within the $t_{RAD(max)}$ limit ensures that $t_{RAC(max)}$ can be met. $t_{RAD(max)}$ is specified as a reference point only. If t_{RAD} is greater than the specified $t_{RAD(max)}$ limit, then access time is controlled by t_{CAA} .
- 11) Either t_{RCH} or t_{RRH} must be satisfied for a read cycle.
- 12) $t_{OFF(max)}$, $t_{OEZ(max)}$ define the time at which the output achieves the open-circuit conditions and are not referenced to output voltage levels. t_{OFF} is referenced from the rising edge of \overline{RAS} or \overline{CAS} , whichever occurs last.
- 13) Either t_{DZC} or t_{DZO} must be satisfied.
- 14) Either t_{CDD} or t_{ODD} must be satisfied.
- 15) t_{WCS} , t_{RWD} , t_{CWD} and t_{AWD} are not restrictive operating parameters. They are included in the data sheet as electrical characteristics only. If $t_{WCS} > t_{WCS(min)}$, the cycle is an early write cycle and data out pin will remain open-circuit (high impedance) through the entire cycle; if $t_{RWD} > t_{RWD(min)}$, $t_{CWD} > t_{CWD(min)}$ and $t_{AWD} > t_{AWD(min)}$, the cycle is a read-write cycle and I/O will contain data read from the selected cells. If neither of the above sets of conditions is satisfied, the condition of I/O (at access time) is indeterminate.
- 16) These parameters are referenced to the \overline{CAS} leading edge in early write cycles and to the \overline{WE} leading edge in read-write cycles.

Waveforms of Write Cycle (Early Write)

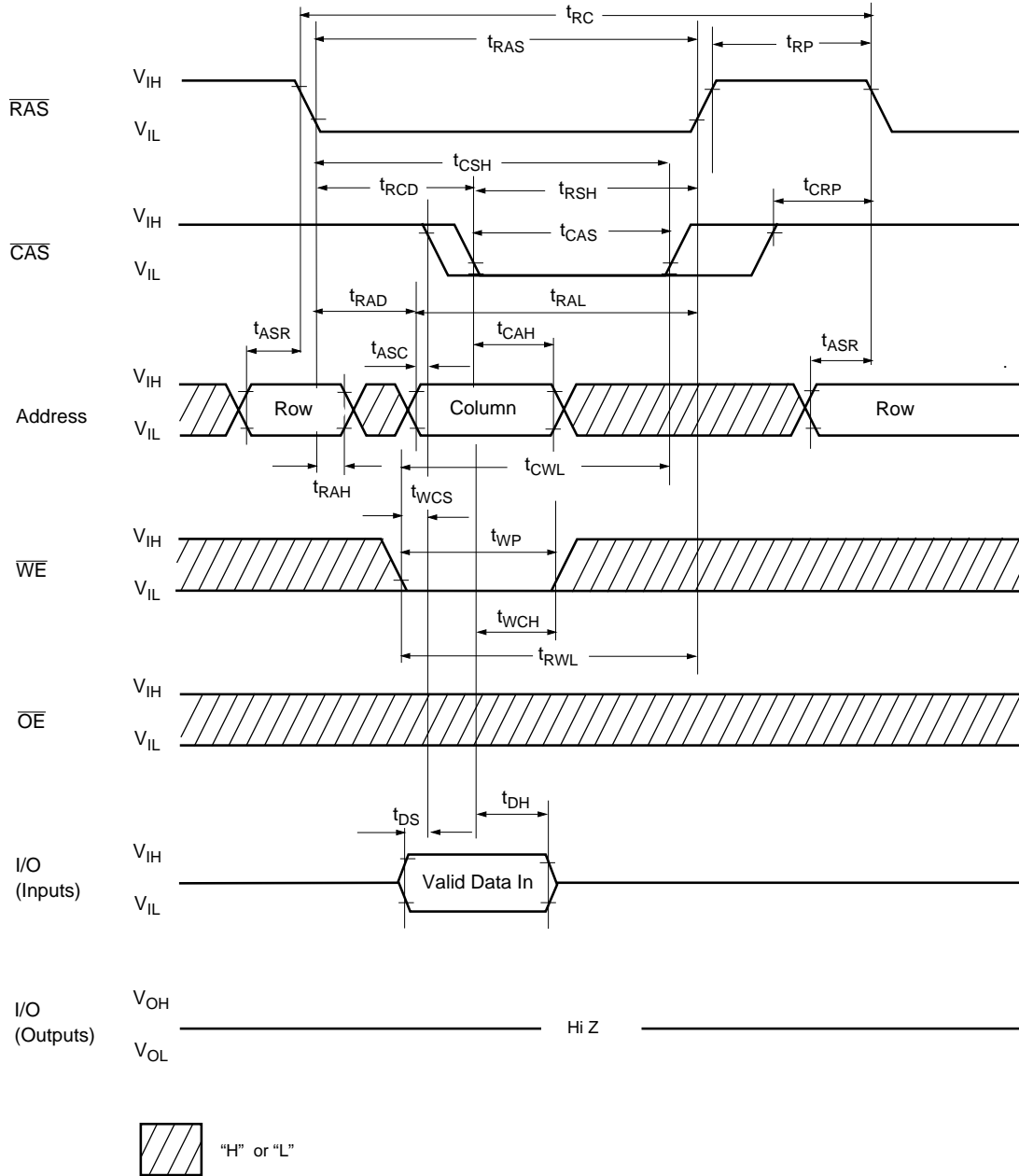

WL2

Waveforms of Write Cycle (\overline{OE} Controlled Write)

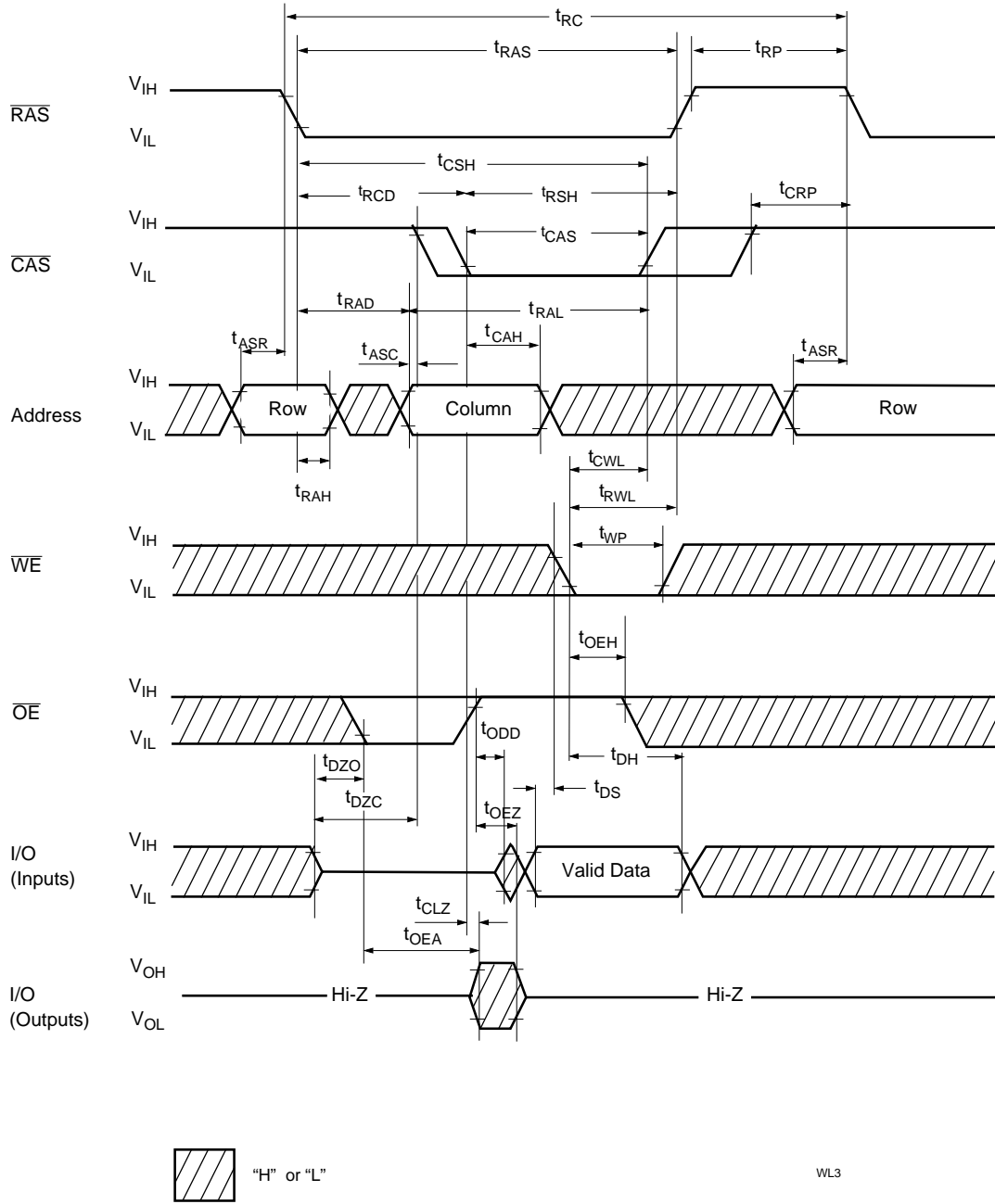

Waveforms of EDO Page Mode Read Cycle

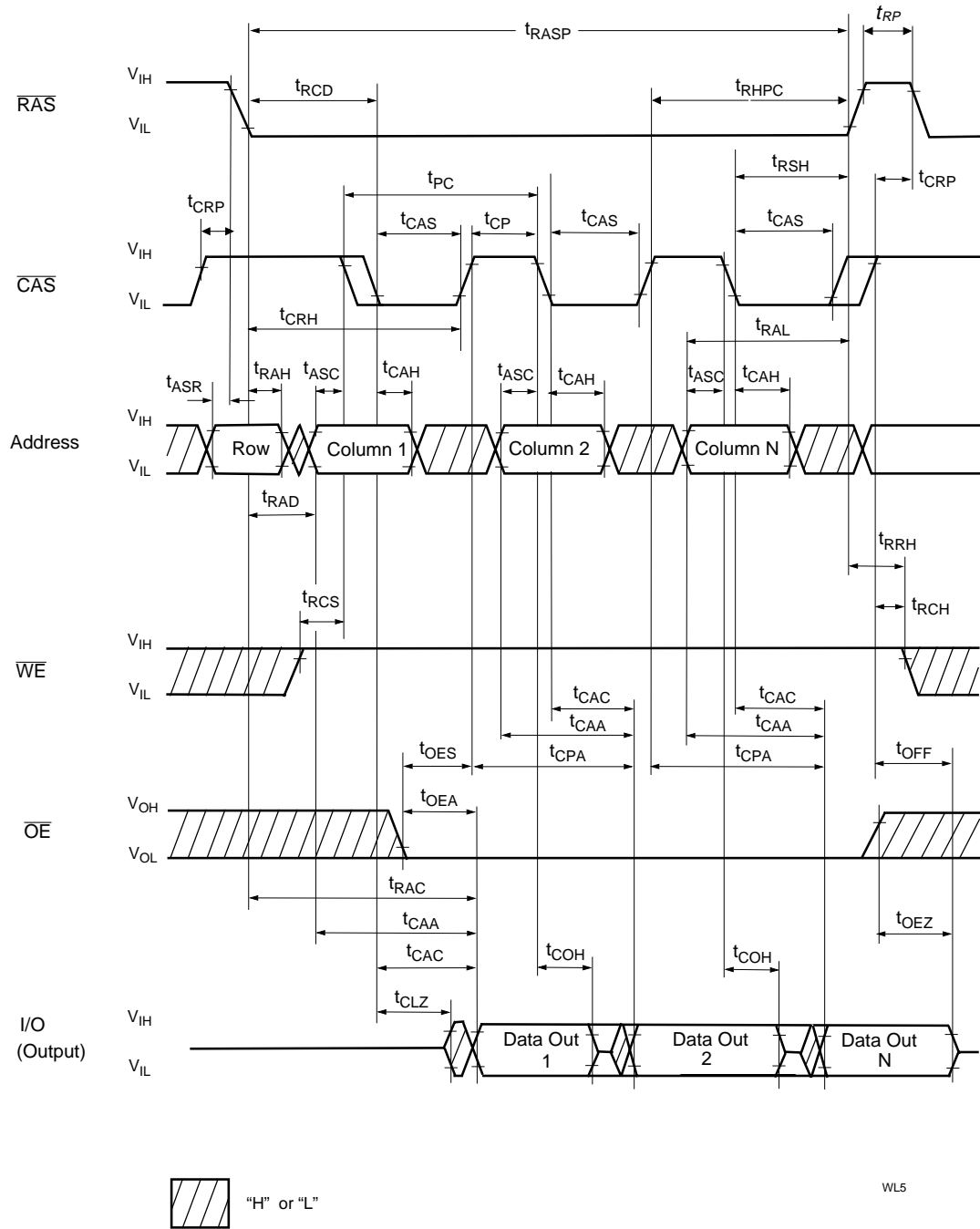

Waveforms of $\overline{\text{RAS}}$ Only Refresh Cycle

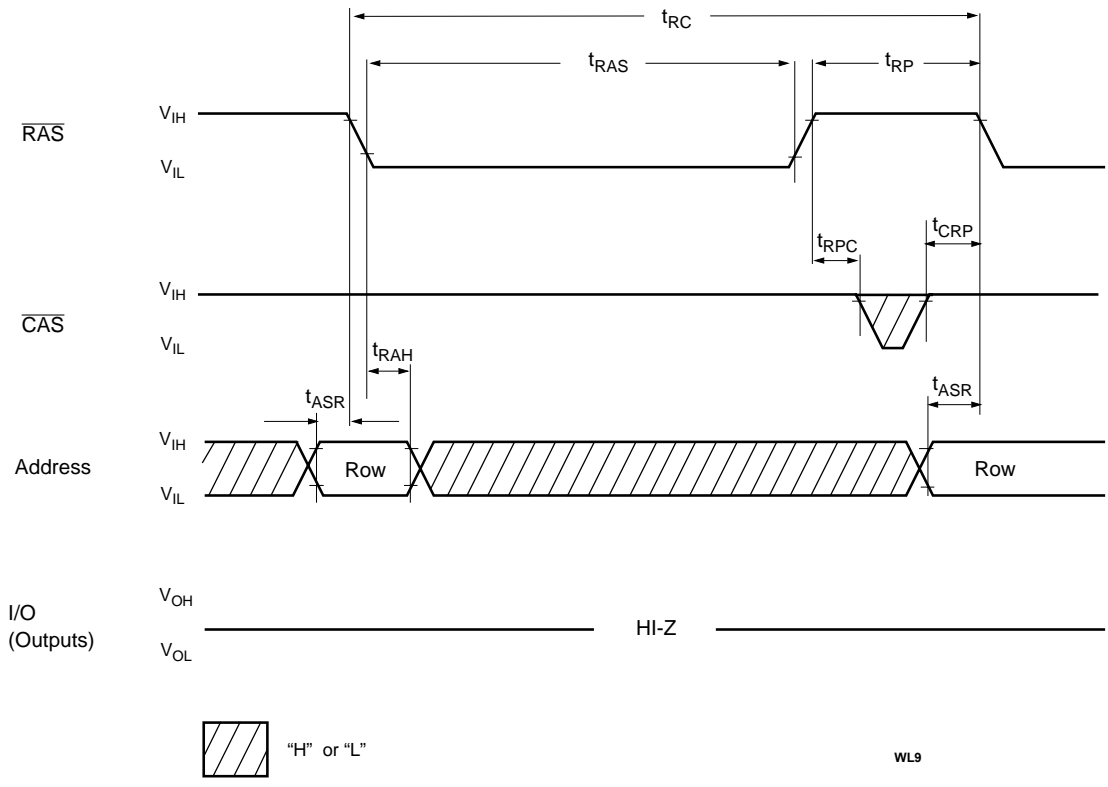

Waveforms of $\overline{\text{CAS}}$ -before- $\overline{\text{RAS}}$ Refresh Cycle

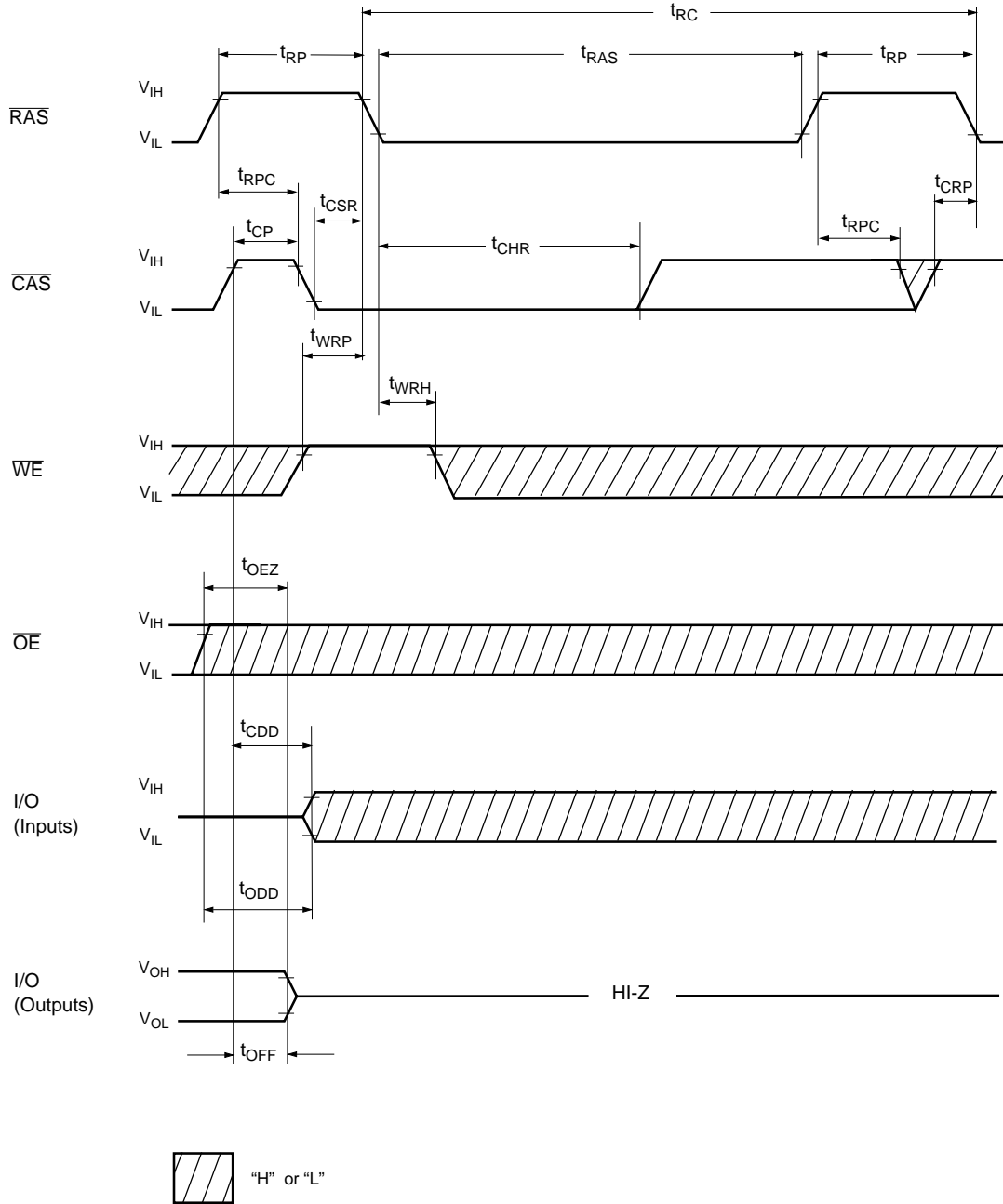

WL10

Waveforms of Hidden Refresh Read Cycle

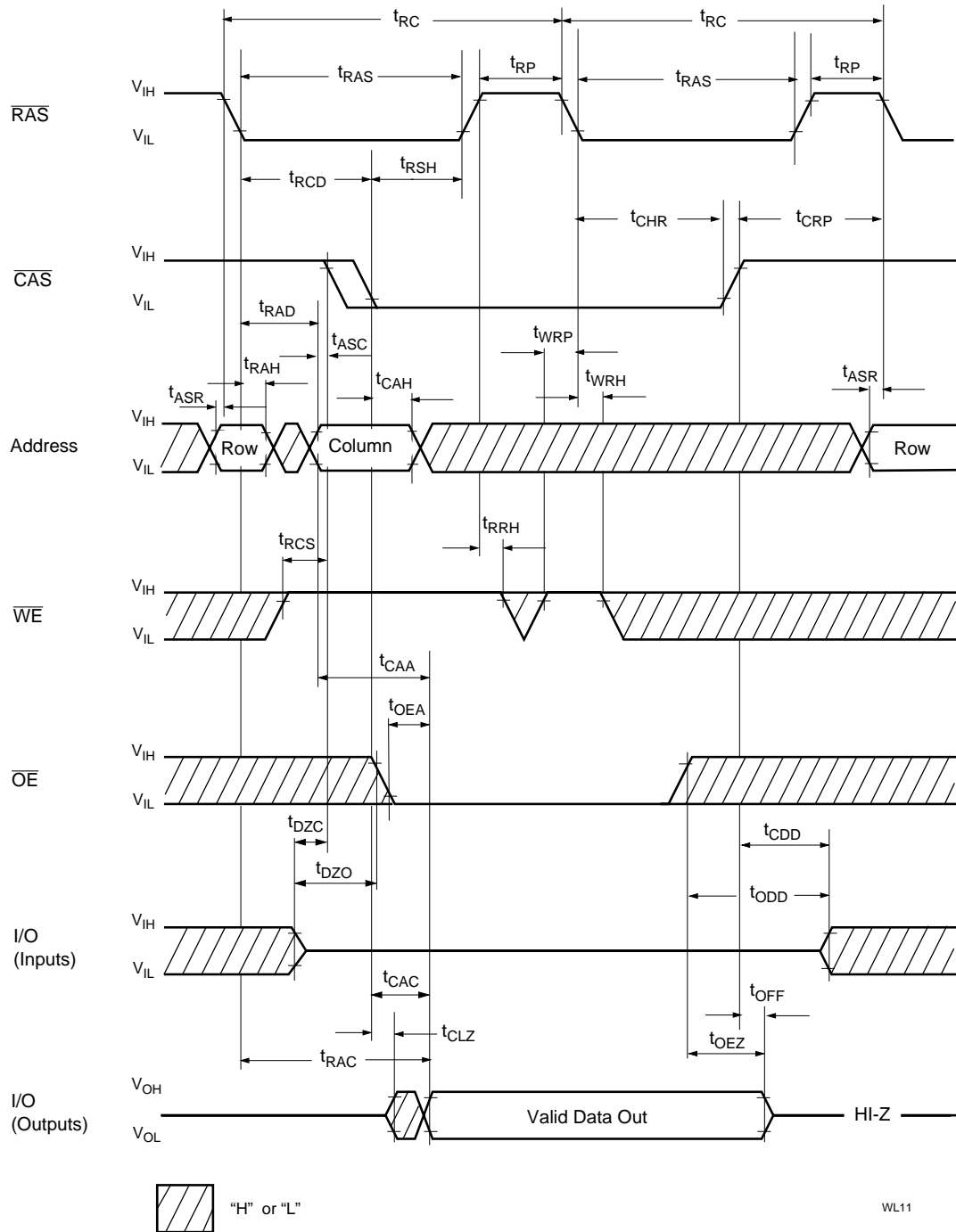

WL11

Waveforms of Hidden Refresh Early Write Cycle

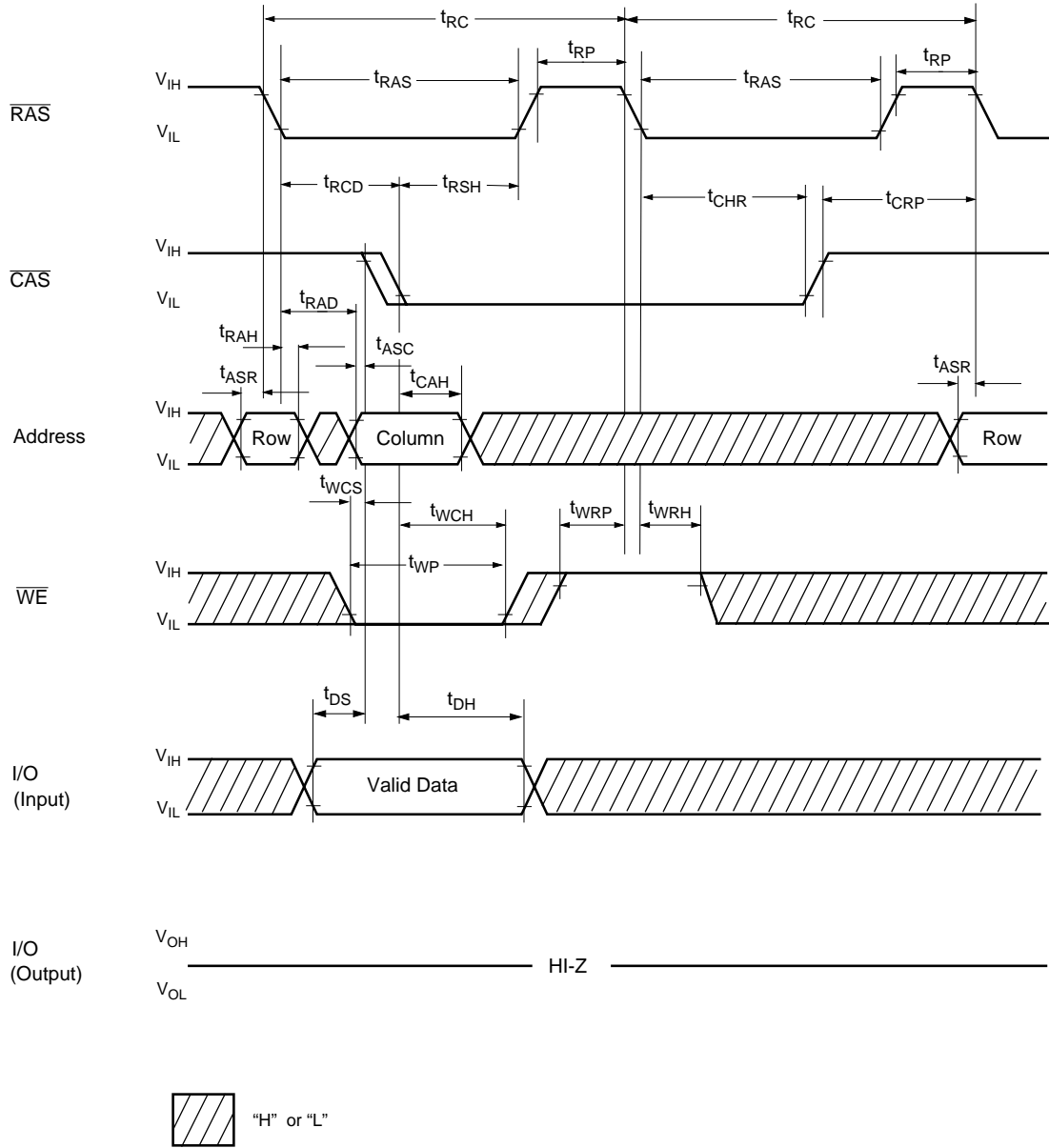

WL12

Waveforms of $\overline{\text{CAS}}$ -before- $\overline{\text{RAS}}$ Refresh Counter Test Cycle

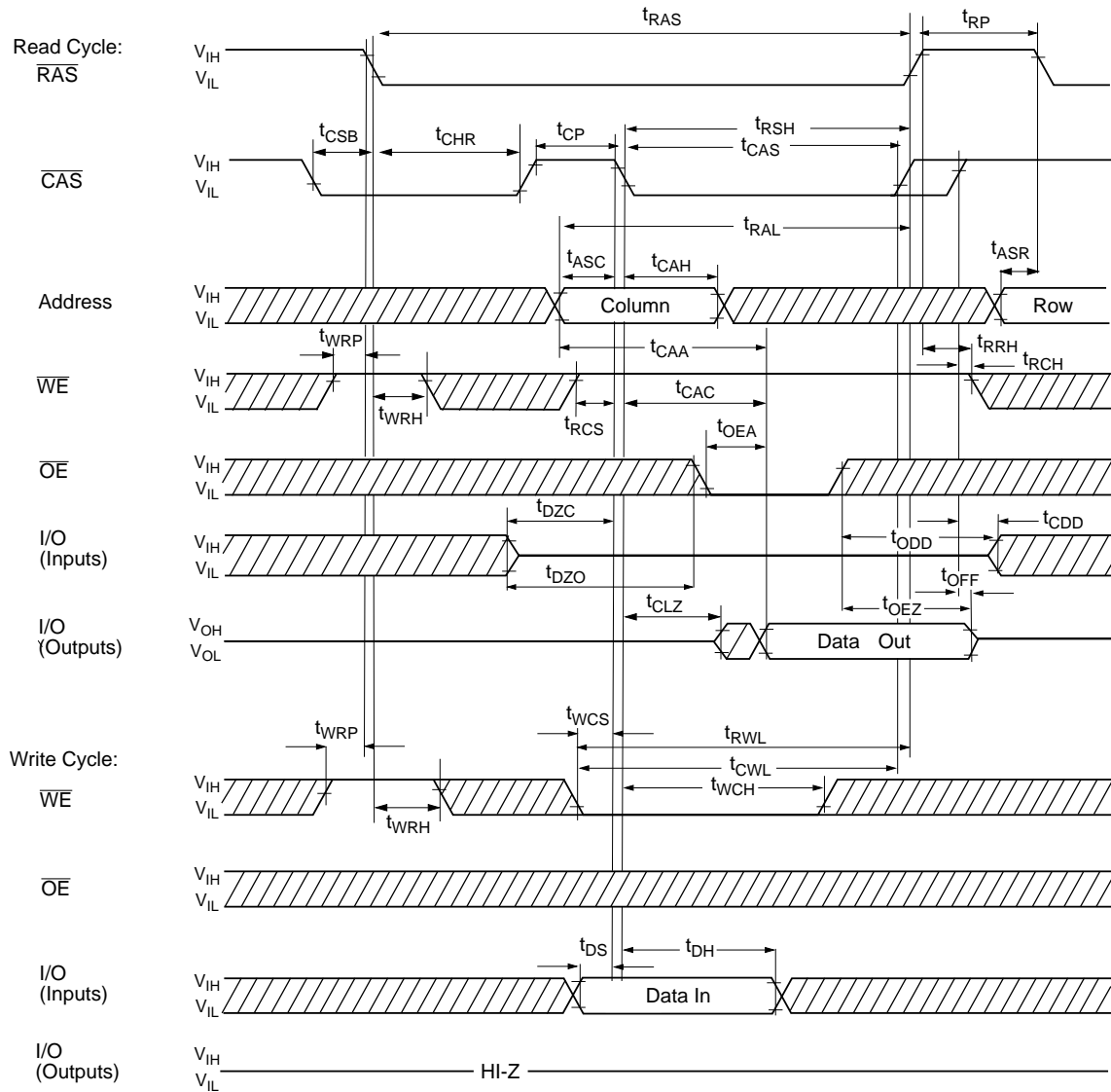

Waveforms of Test Mode Entry

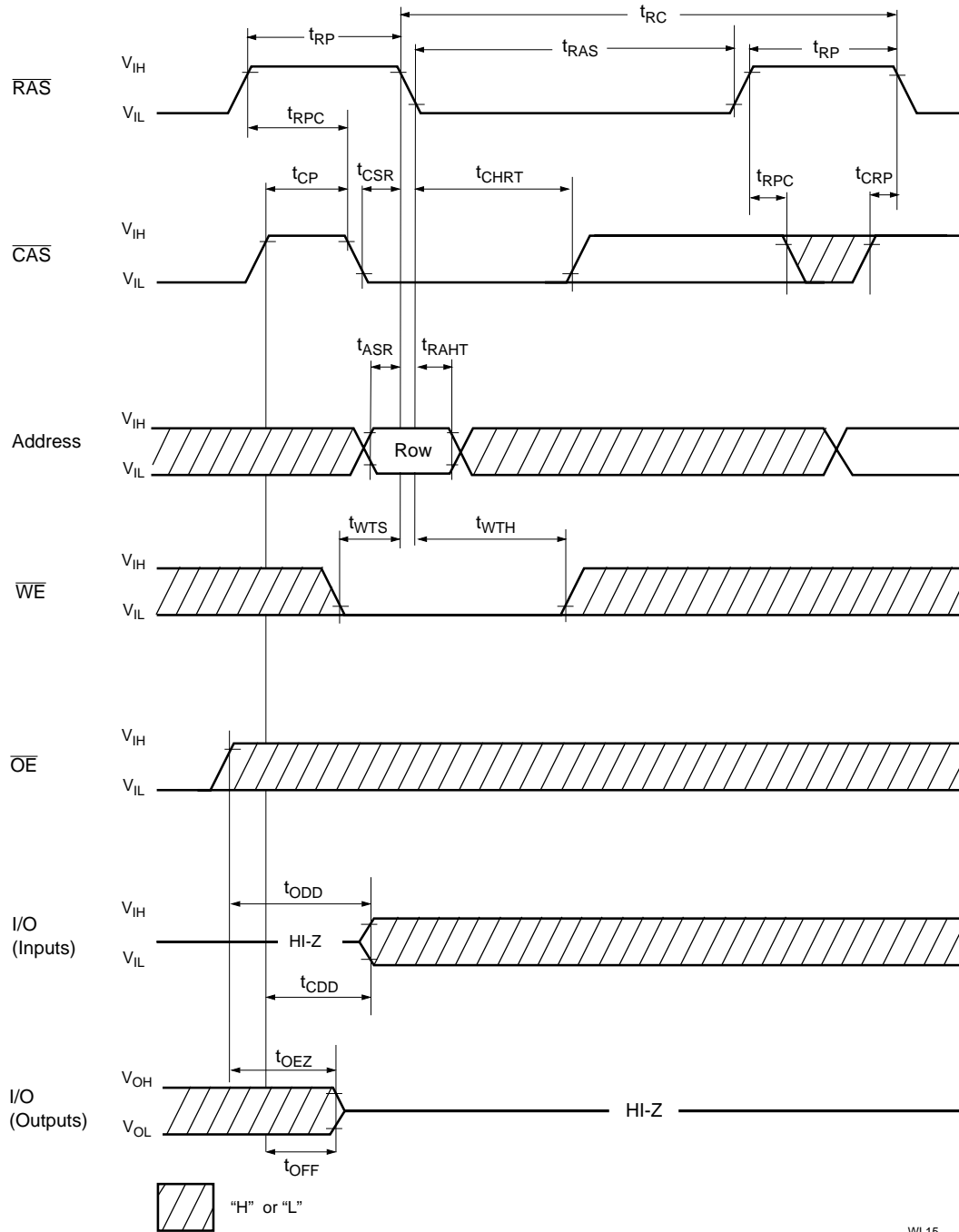

WL15

Test Mode

As the V53C317405A is organized internally as 1M x 16-bits, a test mode cycle using 4:1 compression can be used to improve test time. Note that in the 4M x 4 version the test time is reduced by 1/4 for a N test pattern.

In a test mode “write” the data from each I/O pin is written into four 1M blocks simultaneously (all “1” s or all “0” s). In test mode “read” each I/O output is used for indicating the test mode result. If the internal four bits are equal, the I/O would indicate a “1”.

If they were not equal, the I/O would indicate a “0”. The WCBR cycle (\overline{WE} , \overline{CAS} before \overline{RAS}) puts the device into test mode. To exit from test mode, a “ \overline{CAS} before \overline{RAS} refresh”, “ \overline{RAS} only refresh” or “Hidden refresh” can be used. Refresh during test mode operation can be performed by normal read cycles or by WCBR refresh cycles.

Row addresses A0 through A9 have to kept high to perform a testmode entry cycle. All other addresses are don't care.

Block Diagram in Test Mode

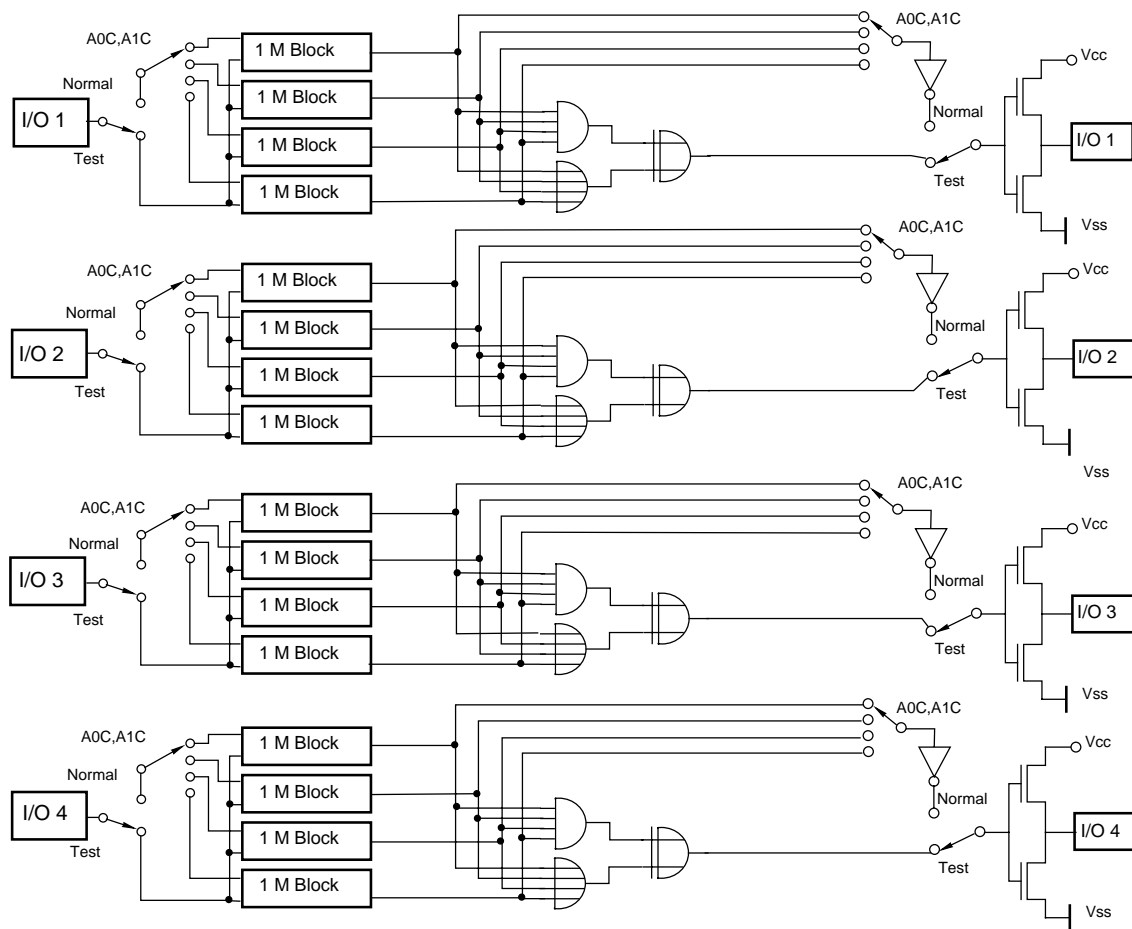

Package Diagrams

24/26-pin 300 mil SOJ

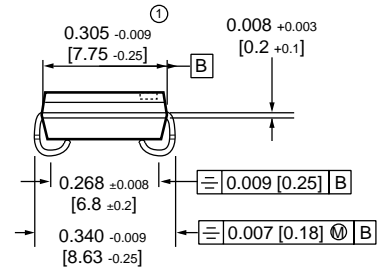
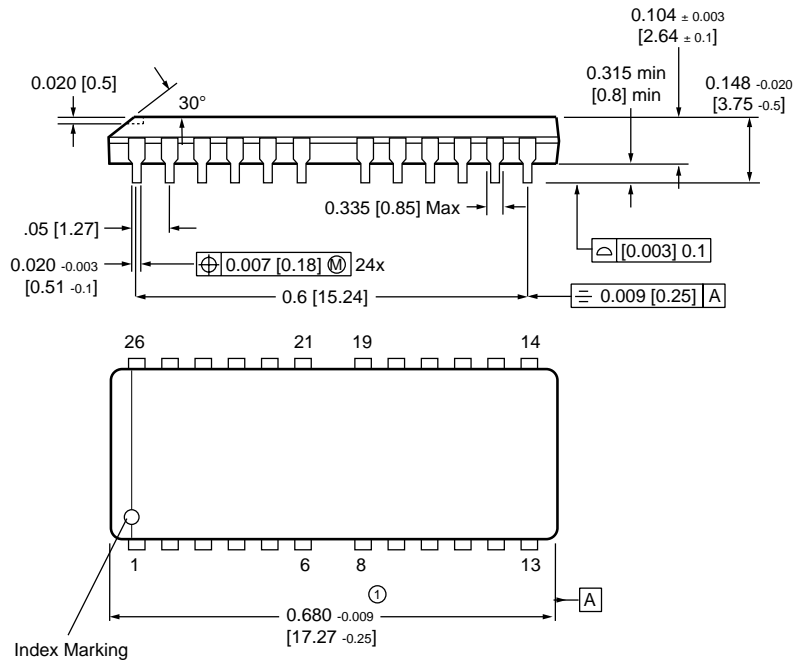

Units in inches [mm]

① Does not include plastic or metal protrusion of 0.15 max. per side

24/26-pin 300 mil TSOP-II

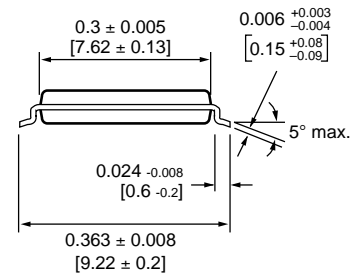
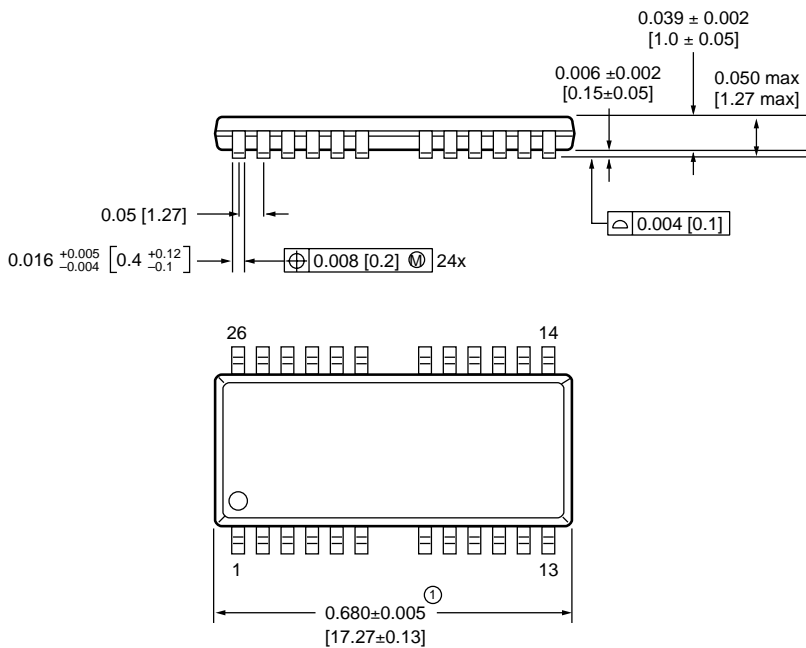

Unit in inches [mm]

① Does not include plastic or metal protrusion of 0.15 max. per side

U.S.A.

3910 NORTH FIRST STREET
SAN JOSE, CA 95134
PHONE: 408-433-6000
FAX: 408-433-0185

HONG KONG

19 DAI FU STREET
TAIPO INDUSTRIAL ESTATE
TAIPO, NT, HONG KONG
PHONE: 852-2665-4883
FAX: 852-2664-7535

TAIWAN

7F, NO. 102
MIN-CHUAN E. ROAD, SEC. 3
TAIPEI
PHONE: 886-2-2545-1213
FAX: 886-2-2545-1209

1 CREATION ROAD I
SCIENCE BASED IND. PARK
HSIN CHU, TAIWAN, R.O.C.
PHONE: 886-3-578-3344
FAX: 886-3-579-2838

JAPAN

WBG MARINE WEST 25F
6, NAKASE 2-CHOME
MIHAMA-KU, CHIBA-SHI
CHIBA 261-71
PHONE: 81-43-299-6000
FAX: 81-43-299-6555

IRELAND & UK

BLOCK A UNIT 2
BROOMFIELD BUSINESS PARK
MALAHIDE
CO. DUBLIN, IRELAND
PHONE: +353 1 8038020
FAX: +353 1 8038049

**GERMANY
(CONTINENTAL
EUROPE & ISRAEL)**

71083 HERRENBERG
BENZSTR. 32
GERMANY
PHONE: +49 7032 2796-0
FAX: +49 7032 2796 22

U.S. SALES OFFICES**NORTHWESTERN**

3910 NORTH FIRST STREET
SAN JOSE, CA 95134
PHONE: 408-433-6000
FAX: 408-433-0185

NORTHEASTERN

SUITE 436
20 TRAFALGAR SQUARE
NASHUA, NH 03063
PHONE: 603-889-4393
FAX: 603-889-9347

SOUTHWESTERN

SUITE 200
5150 E. PACIFIC COAST HWY.
LONG BEACH, CA 90804
PHONE: 562-498-3314
FAX: 562-597-2174

CENTRAL & SOUTHEASTERN

604 FIELDWOOD CIRCLE
RICHARDSON, TX 75081
PHONE: 972-690-1402
FAX: 972-690-0341

The information in this document is subject to change without notice.

MOSEL VITELIC makes no commitment to update or keep current the information contained in this document. No part of this document may be copied or reproduced in any form or by any means without the prior written consent of MOSEL-VITELIC.

MOSEL VITELIC subjects its products to normal quality control sampling techniques which are intended to provide an assurance of high quality products suitable for usual commercial applications. MOSEL VITELIC does not do testing appropriate to provide 100% product quality assurance and does not assume any liability for consequential or incidental arising from any use of its products. If such products are to be used in applications in which personal injury might occur from failure, purchaser must do its own quality assurance testing appropriate to such applications.