



---

# Low Power Flow-through 1-Mbit (16Kx64) Standard 1T-SRAM<sup>®</sup> Embedded Memory Macro M1T1LT18FE64E

---

- **Low Power 1T-SRAM Standard Macro**

- 10-83 MHz operation
- 1-Clock cycle time
- Flow-through read access timing
- Early write mode timing
- 64-Bit wide data buses
- Byte Write Enables
- Simple standard SRAM interface
- Fast delivery

- **Ultra-Dense Memory**

- 3.6mm<sup>2</sup> size per macro instance
- Redundancy & fuses included in macro area

- **Silicon-Proven 1T-SRAM Technology**

- Qualification programs completed
- Products in volume production

- **High Yield and Reliability**

- Built-in redundancy for enhanced yield

- **Standard Logic Process**

- TSMC 0.18µm CL018G process
- Logic design rules
- Uses 4 metal layers
- Routing over macro possible in layers 5+

- **Power**

- Single voltage 1.8V Supply
- Low power consumption

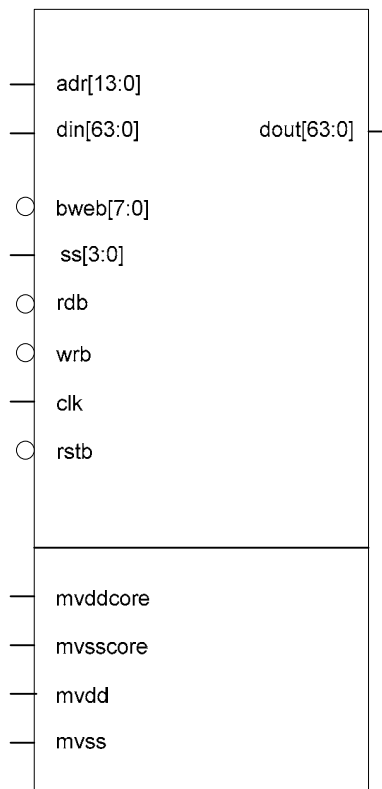

---

## General Description

The M1T1LT18FE64E is a 1Mbit (1,084,576 bits), low power, embedded 1T-SRAM macro. The M1T1LT18FE64E is organized as 16K(16,384) words of 64 bits. The macro employs a flow-through read timing interface with early write timing. Write control over individual bytes in the input data is achieved through the use of the byte write enable (bweb) input signals. The M1T1LT18FE64E macro is implemented using MoSys 1T -SRAM technology, resulting in extremely high density and low power.



Low Power Flow-through 1-Mbit (16Kx64)  
Standard 1T-SRAM<sup>®</sup> Embedded Memory Macro  
M1T1LT18FE64E

**Memory Interface Signal List**

Signal Name	Valid	Logic	Direction	Description
adr[13:0]	Positive clk edge	Positive	Input	Memory address
bwe[7:0]	Positive clk edge	Negative	Input	Memory byte write enables bweb[n] = 0 enables data write bweb[n] = 1 disables data write bweb[7] controls writing of din[63:56] bweb[6] controls writing of din[55:48] ... bweb[0] controls writing of din[7:0]
rdb	Positive clk edge	Negative	Input	Memory read
wrb	Positive clk edge	Negative	Input	Memory write
ssb[3:0]	Positive clk edge	Positive	Input	Speed Select
din[63:0]	Positive clk edge	Positive	Input	Memory data in bus
dout[63:0]	Negative clk edge	Positive	Output	Memory data out bus
rstb	Positive clk edge	Negative	Input	Memory initialization reset
clk	Clock	Positive	Input	Memory Clock
mvddcore				Memory core supply voltage
mvsscore				Memory core ground
mvdd				Memory interface supply voltage
mvss				Memory interface ground

**Recommended Operating Conditions**

Symbol	Parameter	Condition	Min	Max	Units
V <sub>DD</sub>	Supply Voltage Range (1.8V ±10%)	Operating	1.62	1.98	V
T <sub>J</sub>	Junction Temperature	Nominal V <sub>DD</sub>	0	125	°C
t <sub>CYC</sub>	Cycle Time	Operating	12	100	ns
t <sub>CKH</sub>	Clock High	Operating	0.45*t <sub>CYC</sub>	0.55*t <sub>CYC</sub>	ns
t <sub>CKL</sub>	Clock Low	Operating	0.45*t <sub>CYC</sub>	0.55*t <sub>CYC</sub>	ns

**Power Requirements**

Symbol	Condition	Current per Instance	Units
I <sub>DD1</sub>	Operating current, V <sub>DD</sub> =1.8V, clock frequency = 83MHz, memory accessed every clock	0.5	mA/Mhz
I <sub>DD2</sub>	Standby current, V <sub>DD</sub> =1.8V, clock frequency = 20MHz, , memory not accessed	1.4	mA

**Input Loading**

Symbol	Condition	Load Capacitance	Units
C <sub>DIN</sub>	din signal input loading	0.4	pF
C <sub>ADR</sub>	adr signal input loading	0.4	pF
C <sub>CTL</sub>	rdb, wrb and bweb signal input loading	0.4	pF
C <sub>CLK</sub>	clk signal input loading	1.0	pF



Low Power Flow-through 1-Mbit (16Kx64)  
 Standard 1T-SRAM<sup>®</sup> Embedded Memory Macro  
**M1T1LT18FE64E**

**AC Timing Characteristics**

All times in nanoseconds

Bolded numbers reflect worst case design parameters

Parameter	Description	Condition	Slow	Typical	Fast
tAS	Address Setup	Min.	<b>1.5</b>	1.3	1.1
tAH	Address Hold	Min.	<b>1.5</b>	1.3	1.1
tCS	Control Setup	Min.	<b>1.5</b>	1.3	1.1
tCH	Control Hold	Min.	<b>1.5</b>	1.3	1.1
tSS	Speed Setup	Min.	<b>3.0</b>	2.6	2.2
tSH	Speed Hold	Min.	<b>1.0</b>	0.9	0.8
tDS	Write Data Setup	Min.	<b>1.5</b>	1.3	1.1
tDH	Write Data Hold	Min.	<b>1.5</b>	1.3	1.1
tKQ	Clock to Data Valid †	Max.	<b>3.0</b>	2.5	2.0
tKQE	Data valid extrinsic delay per pF	Max.	<b>0.8</b>	0.6	0.4
tKQX	Clock to Data not valid †	Min.	0.3	0.2	<b>0.1</b>

† A weak buffer (bus holder) will drive the data after the rising edge of the clock immediately following a read cycle until tKQX

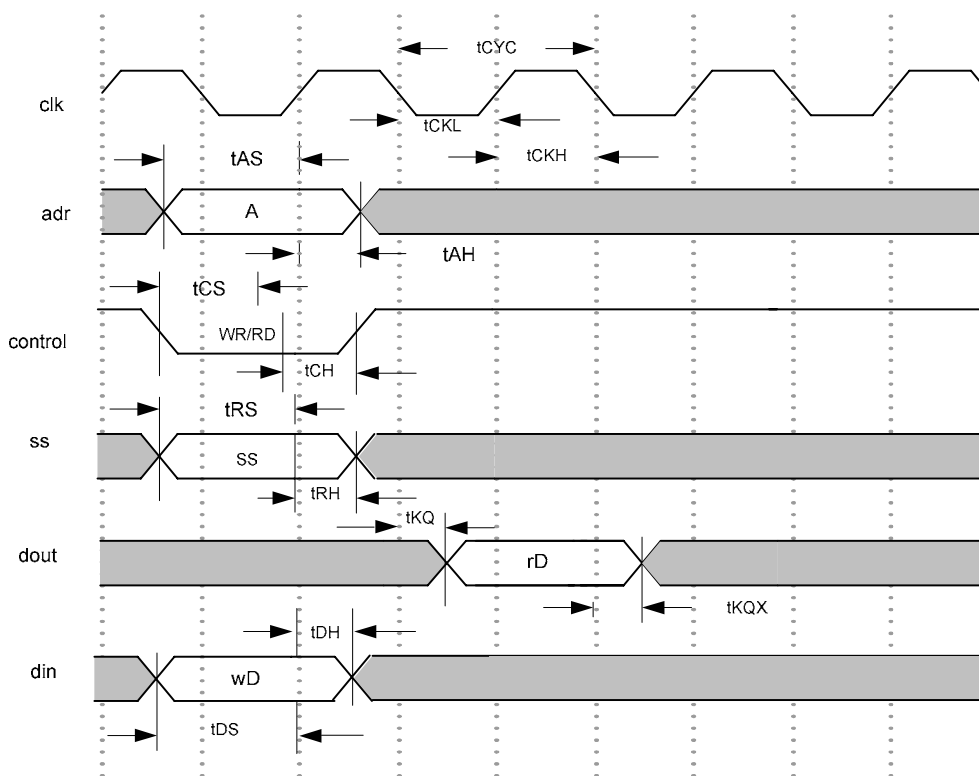

**AC Timing**



**Low Power Flow-through 1-Mbit (16Kx64)**  
**Standard 1T-SRAM<sup>®</sup> Embedded Memory Macro**  
**M1T1LT18FE64E**

Memory macro implements a synchronous reset to force state machines into a known state after power-up. This reset does not clear the memory contents. The clock must be running for at least two cycles before the Reset (rstb) signal will be correctly sampled as shown above. The Reset (rstb) signal must be active for at least ten (10) clock periods to initialize all internal circuitry. Independent of the Reset (rstb) signal, after power has stabilized to a voltage within the operating specification and the clock is operating within its timing specifications, there must be at least 128 clock cycles before any read or write access.

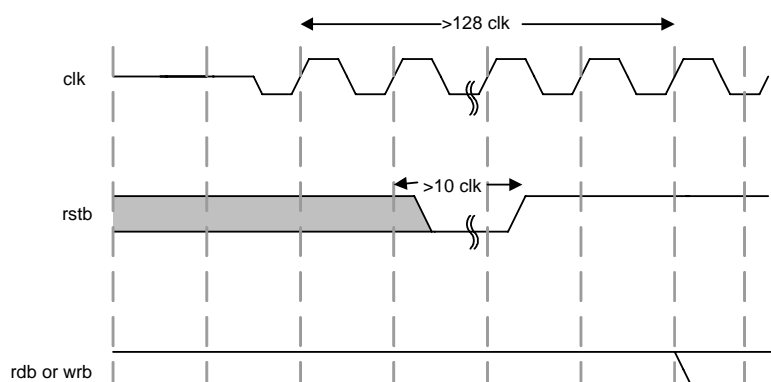

**Initialization Timing**

**SPEED SELECTION**

On this particular macro, the ssl[3:0] signals should be set to a value dependent on the clk memory clock frequency according to the following table to optimize performance:

ss[3]	ss[2]	ss[1]	ss[0]	Clock frequency
0	1	1	1	70-83 MHz
0	1	1	0	60-70 MHz
0	1	0	1	50-60 MHz
0	1	0	0	40-50 MHz
0	0	1	1	30-40 MHz
0	0	1	0	20-30 MHz
0	0	0	1	10-20 MHz
0	0	0	0	Reserved
1	X	X	X	Test Mode



Low Power Flow-through 1-Mbit (16Kx64)  
Standard 1T-SRAM<sup>®</sup> Embedded Memory Macro  
M1T1LT18FE64E

OPERATION TRUTH TABLE

rdb	wrb	Operation
0	0	Illegal
0	1	Read
1	0	Write
1	1	Nop

FUNCTIONAL OPERATION

Address and command clocked in by rising clock edge. Both read and write data transfers occur in the same clock cycle.

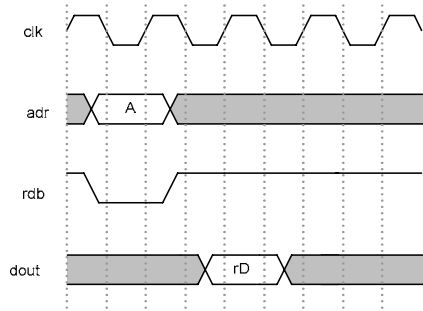

Single Cycle Read Timing

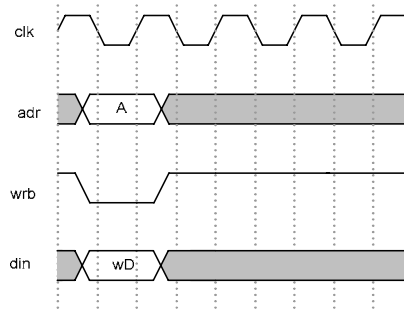

Single Cycle Write Timing



**Low Power Flow-through 1-Mbit (16Kx64)**  
**Standard 1T-SRAM<sup>®</sup> Embedded Memory Macro**  
**M1T1LT18FE64E**

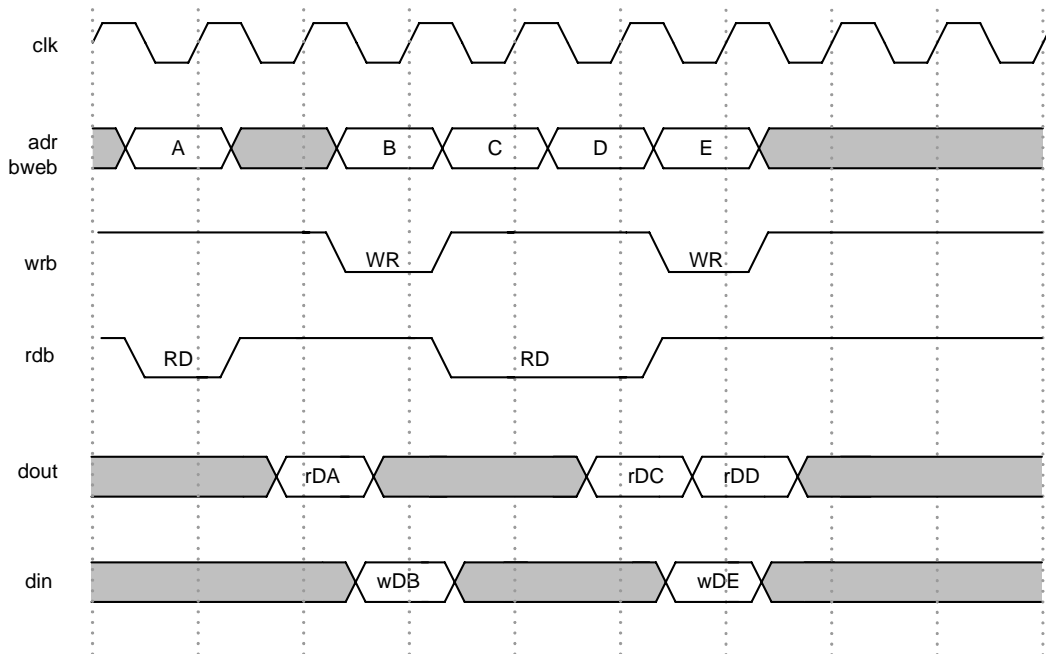

**Multiple Cycle Timing**

**MEMORY BLOCK ESTIMATES**

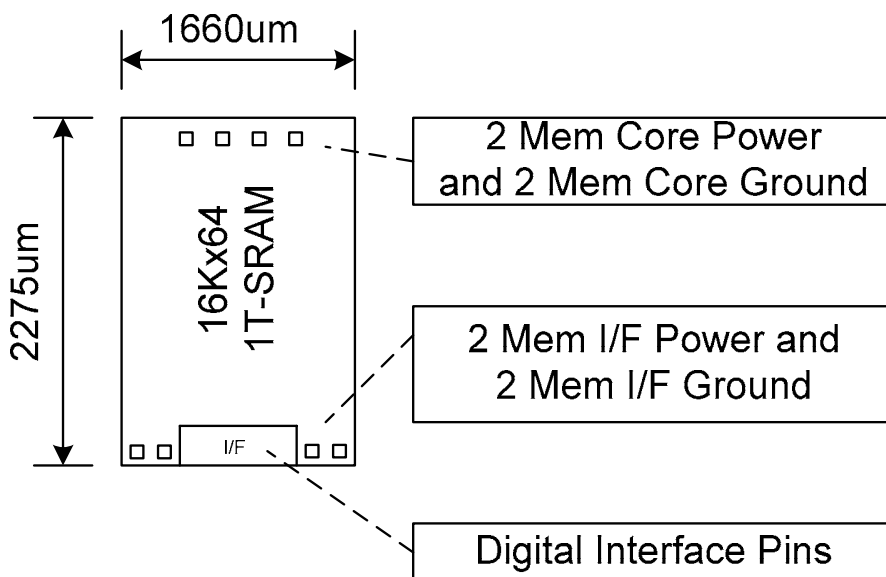

Note: Approximate dimensions. Exact dimensions appear on place and route phantom.

**Physical Layout**