

# Quad EIA-422/423 Line Receiver

Motorola's Quad EIA-422/3 Receiver features four independent receiver chains which comply with EIA Standards for the Electrical Characteristics of Balanced/Unbalanced Voltage Digital Interface Circuits. Receiver outputs are 74LS compatible, three-state structures which are forced to a high impedance state when the appropriate output control pin reaches a logic zero condition. A PNP device buffers each output control pin to assure minimum loading for either logic one or logic zero inputs. In addition, each receiver chain has internal hysteresis circuitry to improve noise margin and discourage output instability for slowly changing input waveforms. A summary of MC3486 features include:

- Four Independent Receiver Chains
- Three-State Outputs
- High Impedance Output Control Inputs (PIA Compatible)
- Internal Hysteresis – 30 mV (Typical) @ Zero Volts Common Mode
- Fast Propagation Times – 25 ns (Typical)
- TTL Compatible
- Single 5.0 V Supply Voltage
- DS 3486 Provides Second Source

7

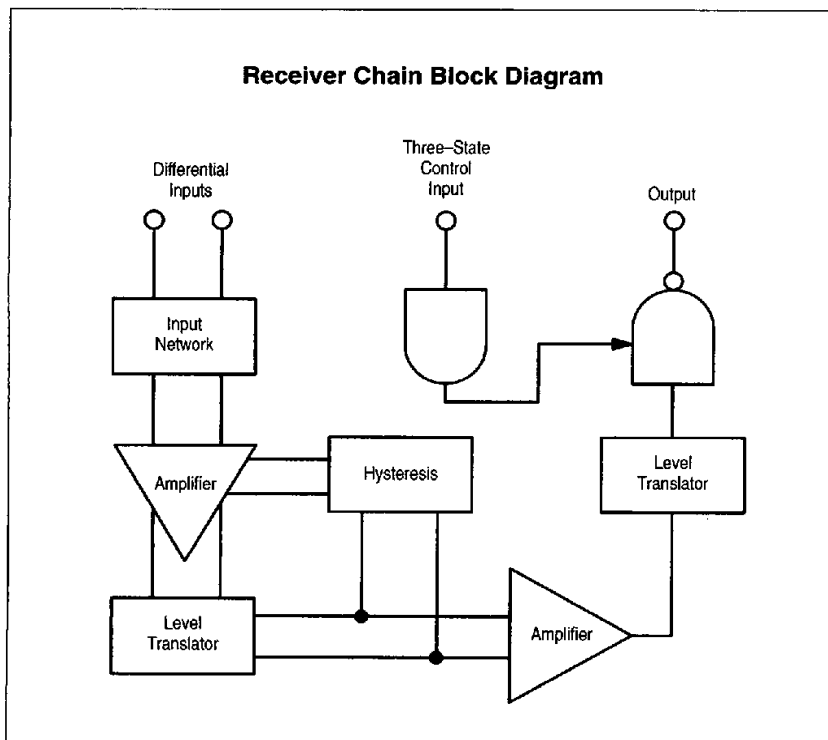

## MC3486

### QUAD EIA-422/3 LINE RECEIVER WITH THREE-STATE OUTPUTS

#### SEMICONDUCTOR TECHNICAL DATA

**D SUFFIX**  
PLASTIC PACKAGE  
CASE 751B  
(SO-16)



**P SUFFIX**  
PLASTIC PACKAGE  
CASE 648

#### PIN CONNECTIONS

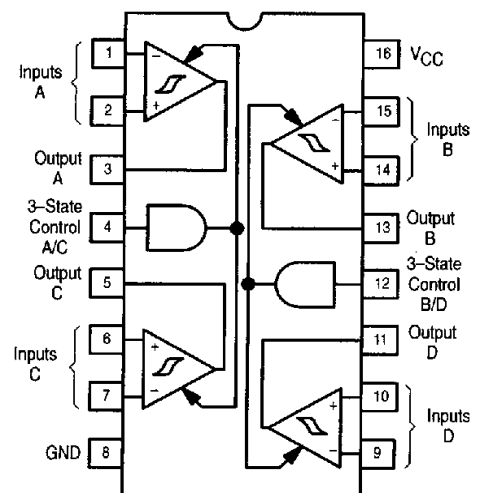

#### ORDERING INFORMATION

Device	Operating Temperature Range	Package
MC3486P	$T_A = 0 \text{ to } +70^\circ\text{C}$	Plastic DIP
MC3486D		SO-16

6367253 0097836 145

# MC3486

## MAXIMUM RATINGS

Rating	Symbol	Value	Unit
Power Supply Voltage	V <sub>CC</sub>	8.0	Vdc
Input Common Mode Voltage	V <sub>ICM</sub>	± 15	Vdc
Input Differential Voltage	V <sub>ID</sub>	± 25	Vdc
Three-State Control Input Voltage	V <sub>I</sub>	8.0	Vdc
Output Sink Current	I <sub>O</sub>	50	mA
Storage Temperature	T <sub>stg</sub>	-65 to +150	°C
Operating Junction Temperature	T <sub>J</sub>	+150	°C

## RECOMMENDED OPERATING CONDITIONS

Rating	Symbol	Value	Unit
Power Supply Voltage	V <sub>CC</sub>	4.75 to 5.25	Vdc
Operating Ambient Temperature	T <sub>A</sub>	0 to +70	°C
Input Common Mode Voltage Range	V <sub>ICR</sub>	-7.0 to +7.0	Vdc
Input Differential Voltage Range	V <sub>IDR</sub>	6.0	Vdc

**ELECTRICAL CHARACTERISTICS** (Unless otherwise noted, minimum and maximum limits apply over recommended temperature and power supply voltage ranges. Typical values are for T<sub>A</sub> = 25°C, V<sub>CC</sub> = 5.0 V and V<sub>IJK</sub> = 0 V. See Note 1.)

Characteristic	Symbol	Min	Typ	Max	Unit
Input Voltage – High Logic State (Three-State Control)	V <sub>IH</sub>	2.0	–	–	V
Input Voltage – Low Logic State (Three-State Control)	V <sub>IL</sub>	–	–	0.8	V
Differential Input Threshold Voltage, Note 2 (-7.0 V ≤ V <sub>IC</sub> ≤ 7.0 V, V <sub>IH</sub> = 2.0 V) (I <sub>O</sub> = -0.4 mA, V <sub>OH</sub> ≥ 2.7 V) (I <sub>O</sub> = 8.0 mA, V <sub>OL</sub> ≥ 0.5 V)	V <sub>TH(D)</sub>	–	–	0.2 -0.2	V
Input Bias Current (V <sub>CC</sub> = 0 V or 5.25 V) (Other Inputs at 0 V) (V <sub>I</sub> = -10 V) (V <sub>I</sub> = -3.0 V) (V <sub>I</sub> = +3.0 V) (V <sub>I</sub> = +10 V)	I <sub>IB(D)</sub>	–	–	-3.25 -1.50 +1.50 +3.25	mA
Input Balance and Output Level (-7.0 V ≤ V <sub>IC</sub> ≤ 7.0 V, V <sub>IH</sub> = 2.0 V, Note 3) (I <sub>O</sub> = -0.4 mA, V <sub>ID</sub> = 0.4 V) (I <sub>O</sub> = 8.0 mA, V <sub>ID</sub> = -0.4 V)	V <sub>OH</sub> V <sub>OL</sub>	2.7 –	– –	– 0.5	V
Output Third State Leakage Current (V <sub>I(D)</sub> = +3.0 V, V <sub>IL</sub> = 0.8 V, V <sub>OL</sub> = 0.5 V) (V <sub>I(D)</sub> = -3.0 V, V <sub>IL</sub> = 0.8 V, V <sub>OH</sub> = 2.7 V)	I <sub>OZ</sub>	–	–	-40 40	μA
Output Short-Circuit Current (V <sub>I(D)</sub> = 3.0 V, V <sub>IH</sub> = 2.0 V, V <sub>O</sub> = 0 V, Note 4)	I <sub>OS</sub>	-15	–	-100	mA
Input Current – Low Logic State (Three-State Control) (V <sub>IL</sub> = 0.5 V)	I <sub>IL</sub>	–	–	-100	μA
Input Current – High Logic State (Three-State Control) (V <sub>IH</sub> = 2.7 V) (V <sub>IH</sub> = 5.25 V)	I <sub>IH</sub>	–	–	20 100	μA
Input Clamp Diode Voltage (Three-State Control) (I <sub>IJK</sub> = -10 mA)	V <sub>IJK</sub>	–	–	-1.5	V
Power Supply Current (V <sub>IL</sub> = 2.0 V)	I <sub>CC</sub>	–	–	85	mA

- NOTES:** 1. All currents into device pins are shown as positive, out of device pins are negative. All voltage referenced to ground unless otherwise noted.  
 2. Differential input threshold voltage and guaranteed output levels are done simultaneously for worst case.  
 3. Refer to EIA-422/3 for exact conditions. Input balance and guaranteed output levels are done simultaneously for worst case.  
 4. Only one output at a time should be shorted.

# MC3486

**SWITCHING CHARACTERISTICS** (Unless otherwise noted,  $V_{CC} = 5.0\text{ V}$  and  $T_A = 25^\circ\text{C}$ .)

Characteristics	Symbol	Min	Typ	Max	Unit
Propagation Delay Time – Differential Inputs to Output (Output High to Low) (Output Low to High)	$t_{PHL(D)}$	–	–	35	ns
	$t_{PLH(D)}$	–	–	30	ns
Propagation Delay time – Three-State Control to Output (Output Low to Third State) (Output High to Third State) (Output Third State to High) (Output Third State to Low)	$t_{PLZ}$	–	–	35	ns
	$t_{PHZ}$	–	–	35	ns
	$t_{PZH}$	–	–	30	ns
	$t_{PZL}$	–	–	30	ns

**Figure 1. Switching Test Circuit and Waveforms**

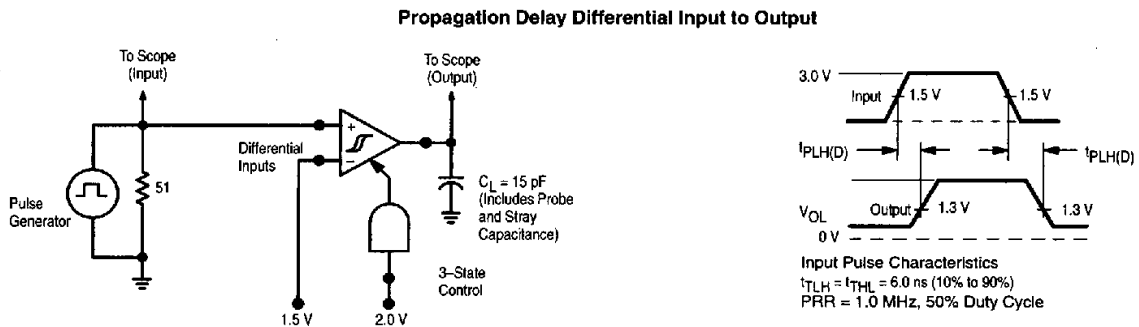

**Figure 2. Propagation Delay Three-State Control Input to Output**

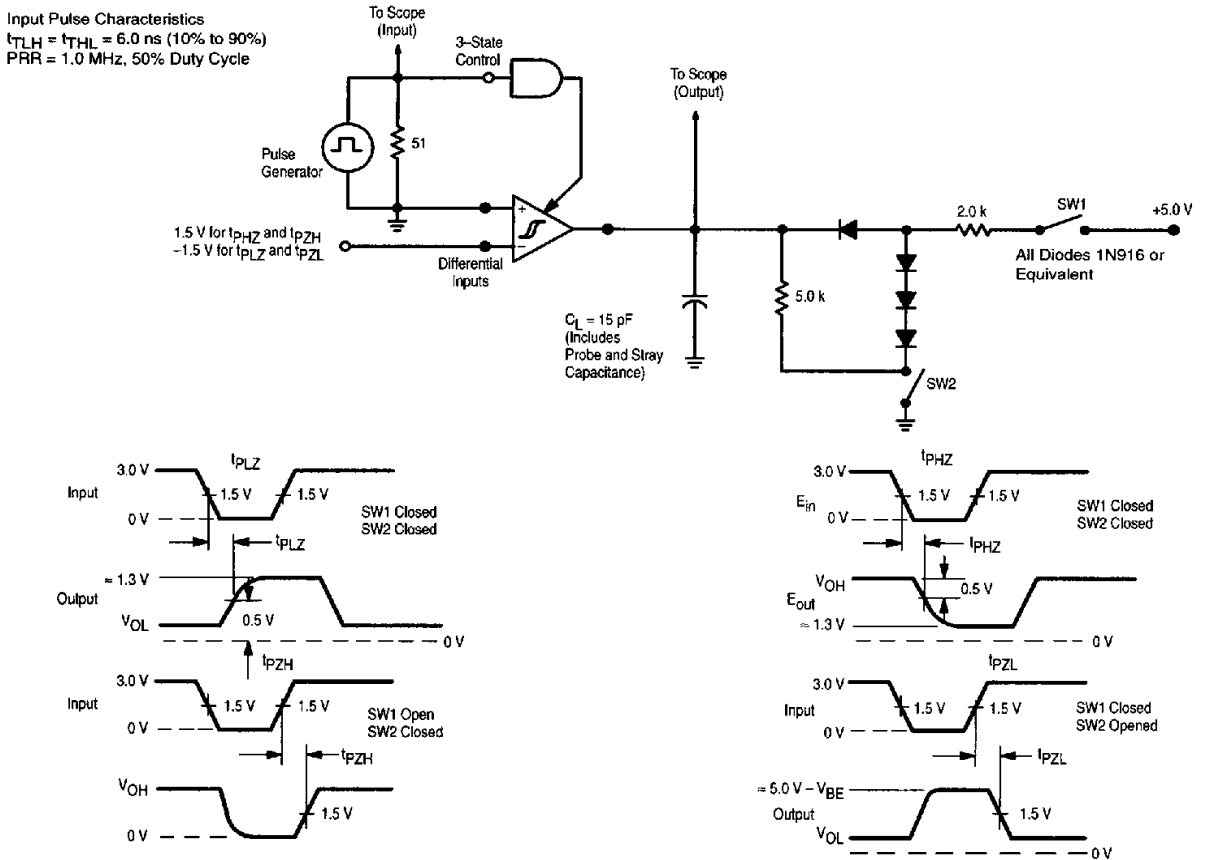

7

6367253 0097838 T18