

Product Preview
**Quad Analog Switch/
Multiplexer/Demultiplexer with
Separate Analog and Digital
Power Supplies**
High-Performance Silicon-Gate CMOS

The MC74HC4316A utilizes silicon-gate CMOS technology to achieve fast propagation delays, low ON resistances, and low OFF-channel leakage current. This bilateral switch/multiplexer/demultiplexer controls analog and digital voltages that may vary across the full analog power-supply range (from V_{CC} to V_{EE}).

The HC4316A is similar in function to the metal-gate CMOS MC14016 and MC14066, and to the High-Speed CMOS HC4016A and HC4066A. Each device has four independent switches. The device control and Enable inputs are compatible with standard CMOS outputs; with pullup resistors, they are compatible with LSTTL outputs. The device has been designed so that the ON resistances (R_{ON}) are much more linear over input voltage than R_{ON} of metal-gate CMOS analog switches. Logic-level translators are provided so that the On/Off Control and Enable logic-level voltages need only be V_{CC} and GND, while the switch is passing signals ranging between V_{CC} and V_{EE} . When the Enable pin (active-low) is high, all four analog switches are turned off.

- Logic-Level Translator for On/Off Control and Enable Inputs
- Fast Switching and Propagation Speeds
- High ON/OFF Output Voltage Ratio
- Diode Protection on All Inputs/Outputs
- Analog Power-Supply Voltage Range ($V_{CC} - V_{EE}$) = 2.0 to 12.0 Volts
- Digital (Control) Power-Supply Voltage Range ($V_{CC} - GND$) = 2.0 to 6.0 Volts, Independent of V_{EE}
- Improved Linearity of ON Resistance
- Chip Complexity: 66 FETs or 16.5 Equivalent Gates

LOGIC DIAGRAM

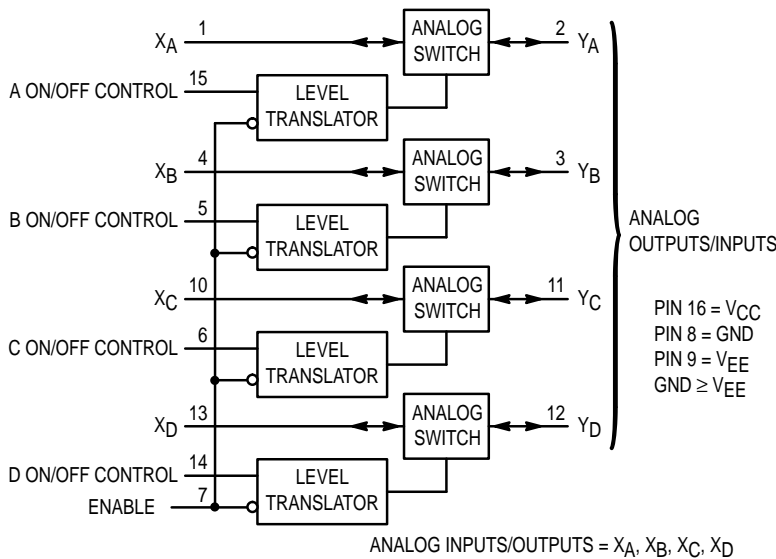

MC74HC4316A

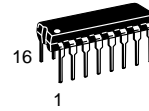

N SUFFIX
PLASTIC PACKAGE
CASE 648-08

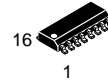

D SUFFIX
SOIC PACKAGE
CASE 751B-05



DT SUFFIX
TSSOP PACKAGE
CASE 948G-01

ORDERING INFORMATION

MC74HCXXXAN Plastic
MC74HCXXXAD SOIC
MC74HCXXXADT TSSOP

PIN ASSIGNMENT

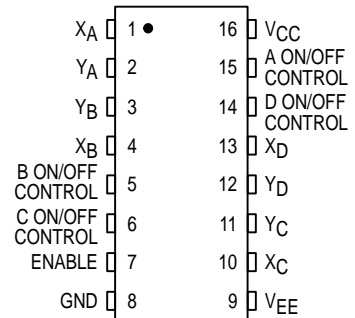

FUNCTION TABLE

Inputs		State of Analog Switch
Enable	On/Off Control	
L	H	On
L	L	Off
H	X	Off

X = don't care

This document contains information on a product under development. Motorola reserves the right to change or discontinue this product without notice.



MC74HC4316A

MAXIMUM RATINGS*

Symbol	Parameter	Value	Unit
V _{CC}	Positive DC Supply Voltage (Ref. to GND) (Ref. to V _{EE})	- 0.5 to + 7.0 - 0.5 to + 14.0	V
V _{EE}	Negative DC Supply Voltage (Ref. to GND)	- 7.0 to + 0.5	V
V _{IS}	Analog Input Voltage	V _{EE} - 0.5 to V _{CC} + 0.5	V
V _{in}	DC Input Voltage (Ref. to GND)	- 0.5 to V _{CC} + 0.5	V
I	DC Current Into or Out of Any Pin	± 25	mA
P _D	Power Dissipation in Still Air Plastic DIP† SOIC Package† TSSOP Package†	750 500 450	mW
T _{stg}	Storage Temperature	- 65 to + 150	°C
T _L	Lead Temperature, 1 mm from Case for 10 Seconds (Plastic DIP, SOIC or TSSOP Package)	260	°C

This device contains protection circuitry to guard against damage due to high static voltages or electric fields. However, precautions must be taken to avoid applications of any voltage higher than maximum rated voltages to this high-impedance circuit. For proper operation, V_{in} and V_{out} should be constrained to the range GND ≤ (V_{in} or V_{out}) ≤ V_{CC}. Unused inputs must always be tied to an appropriate logic voltage level (e.g., either GND or V_{CC}). Unused outputs must be left open. I/O pins must be connected to a properly terminated line or bus.

* Maximum Ratings are those values beyond which damage to the device may occur. Functional operation should be restricted to the Recommended Operating Conditions.

† Derating — Plastic DIP: - 10 mW/°C from 65° to 125°C
SOIC Package: - 7 mW/°C from 65° to 125°C
TSSOP Package: - 6.1 mW/°C from 65° to 125°C

For high frequency or heavy load considerations, see Chapter 2 of the Motorola High-Speed CMOS Data Book (DL129/D).

RECOMMENDED OPERATING CONDITIONS

Symbol	Parameter	Min	Max	Unit	
V _{CC}	Positive DC Supply Voltage (Ref. to GND)	2.0	6.0	V	
V _{EE}	Negative DC Supply Voltage (Ref. to GND)	- 6.0	GND	V	
V _{IS}	Analog Input Voltage	V _{EE}	V _{CC}	V	
V _{in}	Digital Input Voltage (Ref. to GND)	GND	V _{CC}	V	
V _{IO} *	Static or Dynamic Voltage Across Switch	—	1.2	V	
T _A	Operating Temperature, All Package Types	- 55	+ 125	°C	
t _r , t _f	Input Rise and Fall Time (Control or Enable Inputs) (Figure 10)	V _{CC} = 2.0 V V _{CC} = 3.0 V V _{CC} = 4.5 V V _{CC} = 6.0 V	0 0 0 0	1000 600 500 400	ns

* For voltage drops across the switch greater than 1.2 V (switch on), excessive V_{CC} current may be drawn; i.e., the current out of the switch may contain both V_{CC} and switch input components. The reliability of the device will be unaffected unless the Maximum Ratings are exceeded.

DC ELECTRICAL CHARACTERISTICS Digital Section (Voltages Referenced to GND) V_{EE} = GND Except Where Noted

Symbol	Parameter	Test Conditions	V _{CC} V	Guaranteed Limit			Unit
				- 55 to 25°C	≤ 85°C	≤ 125°C	
V _{IH}	Minimum High-Level Voltage, Control or Enable Inputs	R _{on} = Per Spec	2.0	1.5	1.5	1.5	V
			3.0	2.1	2.1	2.1	
			4.5	3.15	3.15	3.15	
			6.0	4.2	4.2	4.2	
V _{IL}	Maximum Low-Level Voltage, Control or Enable Inputs	R _{on} = Per Spec	2.0	0.5	0.5	0.5	V
			3.0	0.9	0.9	0.9	
			4.5	1.35	1.35	1.35	
			6.0	1.8	1.8	1.8	
I _{in}	Maximum Input Leakage Current, Control or Enable Inputs	V _{in} = V _{CC} or GND V _{EE} = - 6.0 V	6.0	± 0.1	± 1.0	± 1.0	µA
I _{CC}	Maximum Quiescent Supply Current (per Package)	V _{in} = V _{CC} or GND V _{IO} = 0 V V _{EE} = GND V _{EE} = - 6.0	6.0	2	20	40	µA
			6.0	4	40	160	

NOTE: Information on typical parametric values can be found in Chapter 2 of the Motorola High-Speed CMOS Data Book (DL129/D).

DC ELECTRICAL CHARACTERISTICS Analog Section (Voltages Referenced to V_{EE})

Symbol	Parameter	Test Conditions	V_{CC} V	V_{EE} V	Guaranteed Limit			Unit	
					- 55 to 25°C	≤ 85°C	≤ 125°C		
R_{on}	Maximum "ON" Resistance	$V_{in} = V_{IH}$ $V_{IS} = V_{CC}$ to V_{EE} $I_S \leq 2.0$ mA (Figures 1, 2)	2.0*	0.0	—	—	—	Ω	
			4.5	0.0	160	200	240		
			4.5	- 4.5	90	110	130		
			6.0	- 6.0	90	110	130		
		$V_{in} = V_{IH}$ $V_{IS} = V_{CC}$ or V_{EE} (Endpoints) $I_S \leq 2.0$ mA (Figures 1, 2)	2.0	0.0	—	—	—		
			4.5	0.0	90	115	140		
			4.5	- 4.5	70	90	105		
			6.0	- 6.0	70	90	105		
ΔR_{on}	Maximum Difference in "ON" Resistance Between Any Two Channels in the Same Package	$V_{in} = V_{IH}$ $V_{IS} = 1/2 (V_{CC} - V_{EE})$ $I_S \leq 2.0$ mA	2.0	0.0	—	—	—	Ω	
			4.5	0.0	20	25	30		
			4.5	- 4.5	15	20	25		
			6.0	- 6.0	15	20	25		
I_{off}	Maximum Off-Channel Leakage Current, Any One Channel	$V_{in} = V_{IL}$ $V_{IO} = V_{CC}$ or V_{EE} Switch Off (Figure 3)	6.0	- 6.0	0.1	0.5	1.0	μ A	
I_{on}	Maximum On-Channel Leakage Current, Any One Channel	$V_{in} = V_{IH}$ $V_{IS} = V_{CC}$ or V_{EE} (Figure 4)	6.0	- 6.0	0.1	0.5	1.0	μ A	

* At supply voltage ($V_{CC} - V_{EE}$) approaching 2 V the analog switch-on resistance becomes extremely non-linear. Therefore, for low-voltage operation, it is recommended that these devices only be used to control digital signals.

NOTE: Information on typical parametric values can be found in Chapter 2 of the Motorola High-Speed CMOS Data Book (DL129/D).

AC ELECTRICAL CHARACTERISTICS ($C_L = 50$ pF, Control or Enable $t_r = t_f = 6$ ns, $V_{EE} = GND$)

Symbol	Parameter	V_{CC} V	Guaranteed Limit			Unit
			- 55 to 25°C	≤ 85°C	≤ 125°C	
t_{PLH} , t_{PHL}	Maximum Propagation Delay, Analog Input to Analog Output (Figures 8 and 9)	2.0	40	50	60	ns
		4.5	6	8	9	
		6.0	5	7	8	
t_{PLZ} , t_{PHZ}	Maximum Propagation Delay, Control or Enable to Analog Output (Figures 10 and 11)	2.0	130	160	200	ns
		4.5	40	50	60	
		6.0	30	40	50	
t_{PZL} , t_{PZH}	Maximum Propagation Delay, Control or Enable to Analog Output (Figures 10 and 11)	2.0	140	175	250	ns
		4.5	40	50	60	
		6.0	30	40	50	
C	Maximum Capacitance ON/OFF Control and Enable Inputs Control Input = GND Analog I/O Feedthrough	—	10	10	10	pF
		—	35	35	35	
		—	1.0	1.0	1.0	

NOTES:

- For propagation delays with loads other than 50 pF, see Chapter 2 of the Motorola High-Speed CMOS Data Book (DL129/D).
- Information on typical parametric values can be found in Chapter 2 of the Motorola High-Speed CMOS Data Book (DL129/D).

C _{PD}	Power Dissipation Capacitance (Per Switch) (Figure 13)*	Typical @ 25°C, $V_{CC} = 5.0$ V		pF
		15		

* Used to determine the no-load dynamic power consumption: $P_D = C_{PD} V_{CC}^2 f + I_{CC} V_{CC}$. For load considerations, see Chapter 2 of the Motorola High-Speed CMOS Data Book (DL129/D).

MC74HC4316A

ADDITIONAL APPLICATION CHARACTERISTICS (GND = 0 V)

Symbol	Parameter	Test Conditions	V _{CC} V	V _{EE} V	Limit* 25°C	Unit
BW	Maximum On-Channel Bandwidth or Minimum Frequency Response (Figure 5)	f _{in} = 1 MHz Sine Wave Adjust f _{in} Voltage to Obtain 0 dBm at V _{OS} Increase f _{in} Frequency Until dB Meter Reads -3 dB R _L = 50 Ω, C _L = 10 pF	2.25 4.50 6.00	-2.25 -4.50 -6.00	150 160 160	MHz
—	Off-Channel Feedthrough Isolation (Figure 6)	f _{in} ≡ Sine Wave Adjust f _{in} Voltage to Obtain 0 dBm at V _{IS} f _{in} = 10 kHz, R _L = 600 Ω, C _L = 50 pF f _{in} = 1.0 MHz, R _L = 50 Ω, C _L = 10 pF	2.25 4.50 6.00 2.25 4.50 6.00	-2.25 -4.50 -6.00 -2.25 -4.50 -6.00	-50 -50 -50 -40 -40 -40	dB
—	Feedthrough Noise, Control to Switch (Figure 7)	V _{in} ≤ 1 MHz Square Wave (t _r = t _f = 6 ns) Adjust R _L at Setup so that I _S = 0 A R _L = 600 Ω, C _L = 50 pF R _L = 10 kΩ, C _L = 10 pF	2.25 4.50 6.00 2.25 4.50 6.00	-2.25 -4.50 -6.00 -2.25 -4.50 -6.00	60 130 200 30 65 100	
—	Crosstalk Between Any Two Switches (Figure 12)	f _{in} ≡ Sine Wave Adjust f _{in} Voltage to Obtain 0 dBm at V _{IS} f _{in} = 10 kHz, R _L = 600 Ω, C _L = 50 pF f _{in} = 1.0 MHz, R _L = 50 Ω, C _L = 10 pF	2.25 4.50 6.00 2.25 4.50 6.00	-2.25 -4.50 -6.00 -2.25 -4.50 -6.00	-70 -70 -70 -80 -80 -80	dB
THD	Total Harmonic Distortion (Figure 14)	f _{in} = 1 kHz, R _L = 10 kΩ, C _L = 50 pF THD = THD _{Measured} - THD _{Source} V _{IS} = 4.0 V _{pp} sine wave V _{IS} = 8.0 V _{pp} sine wave V _{IS} = 11.0 V _{pp} sine wave	2.25 4.50 6.00	-2.25 -4.50 -6.00	0.10 0.06 0.04	

* Limits not tested. Determined by design and verified by qualification.

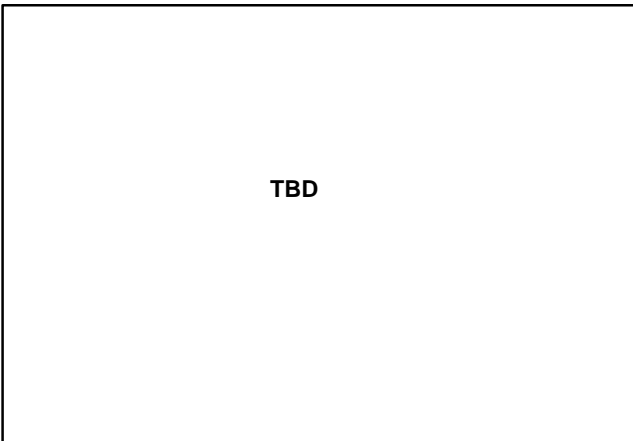

Figure 1a. Typical On Resistance,
 $V_{CC} - V_{EE} = 2.0 \text{ V}$

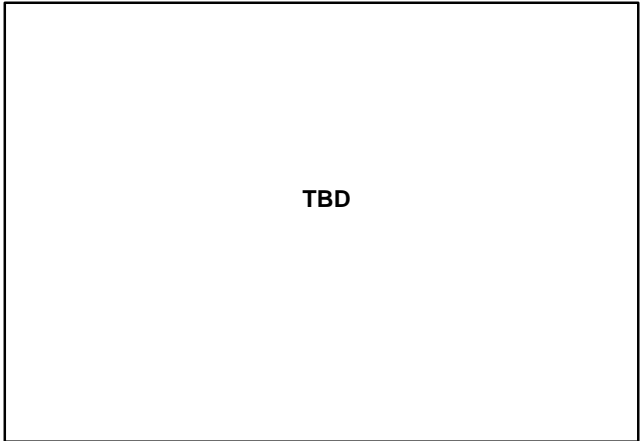

Figure 1b. Typical On Resistance,
 $V_{CC} - V_{EE} = 4.5 \text{ V}$

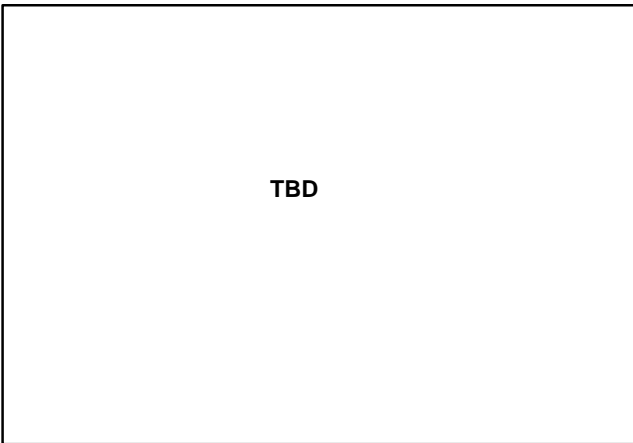

Figure 1c. Typical On Resistance,
 $V_{CC} - V_{EE} = 6.0 \text{ V}$

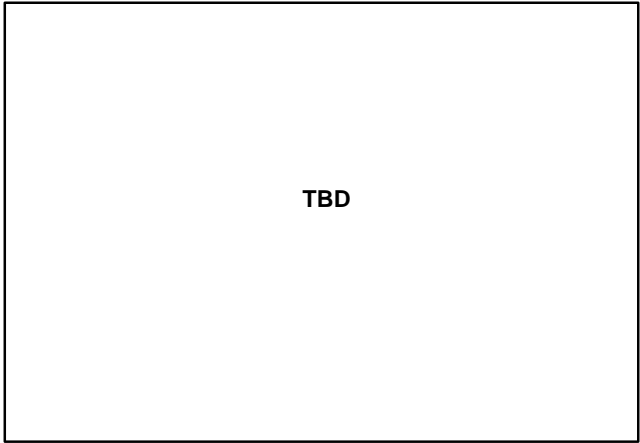

Figure 1d. Typical On Resistance,
 $V_{CC} - V_{EE} = 9.0 \text{ V}$

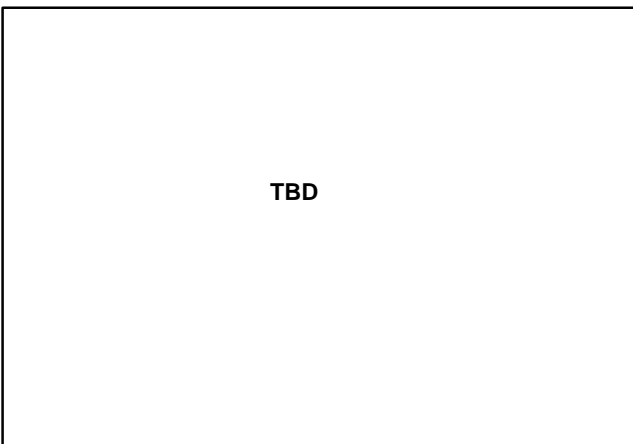

Figure 1e. Typical On Resistance,

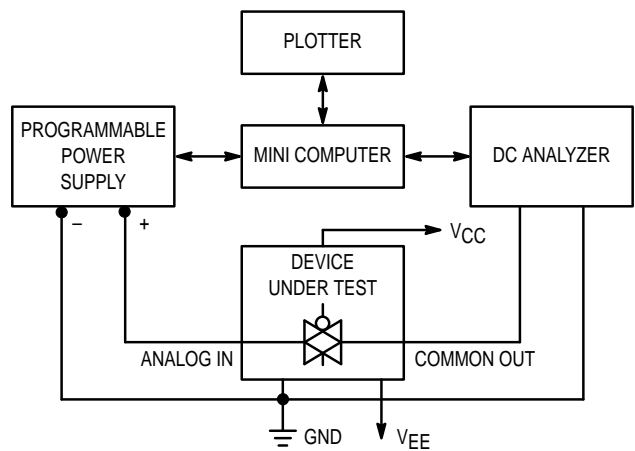

Figure 2. On Resistance Test Set-Up

MC74HC4316A

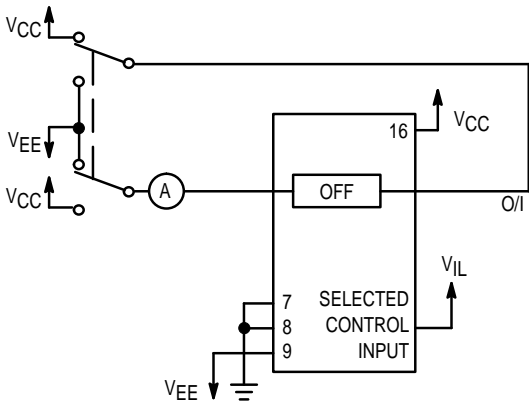

Figure 3. Maximum Off Channel Leakage Current, Any One Channel, Test Set-Up

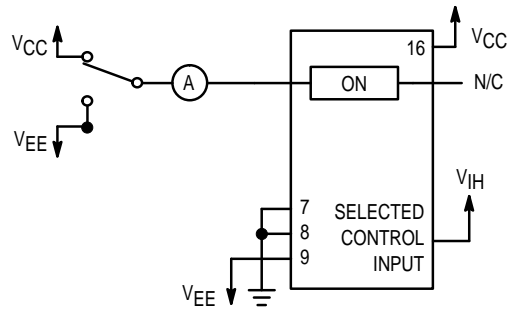
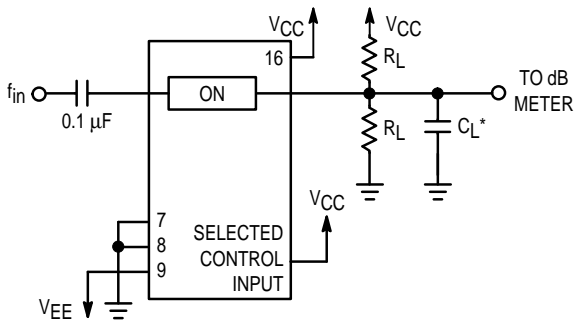
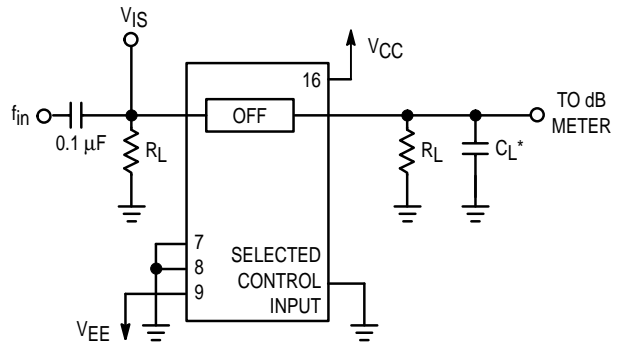

Figure 4. Maximum On Channel Leakage Current, Test Set-Up



*Includes all probe and jig capacitance.

Figure 5. Maximum On-Channel Bandwidth Test Set-Up



*Includes all probe and jig capacitance.

Figure 6. Off-Channel Feedthrough Isolation, Test Set-Up

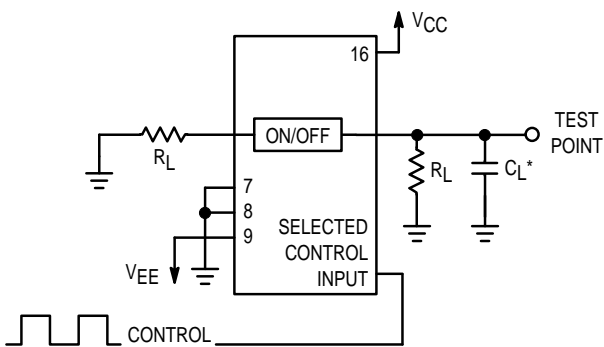

*Includes all probe and jig capacitance.

Figure 7. Feedthrough Noise, Control to Analog Out, Test Set-Up

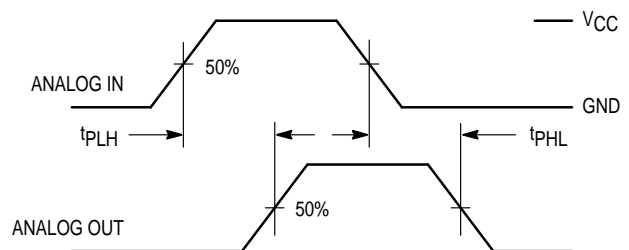
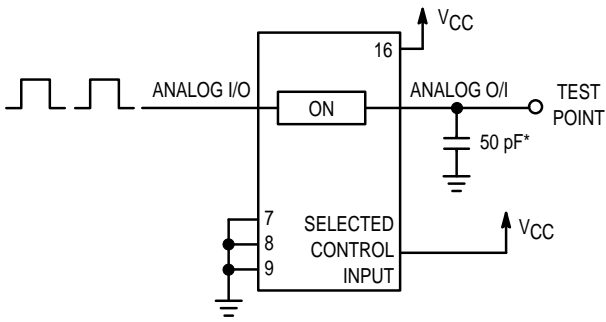

Figure 8. Propagation Delays, Analog In to Analog Out



*Includes all probe and jig capacitance.

Figure 9. Propagation Delay Test Set-Up

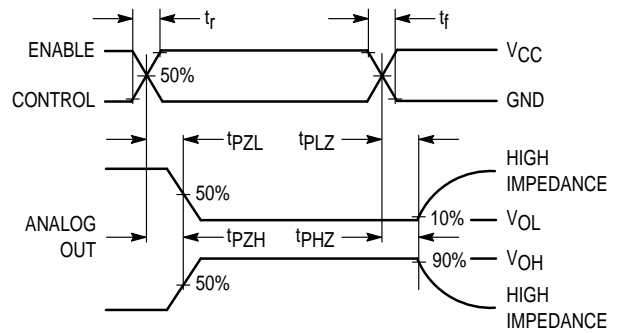
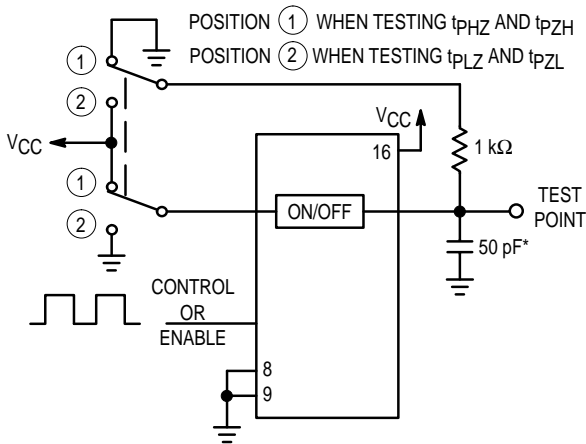
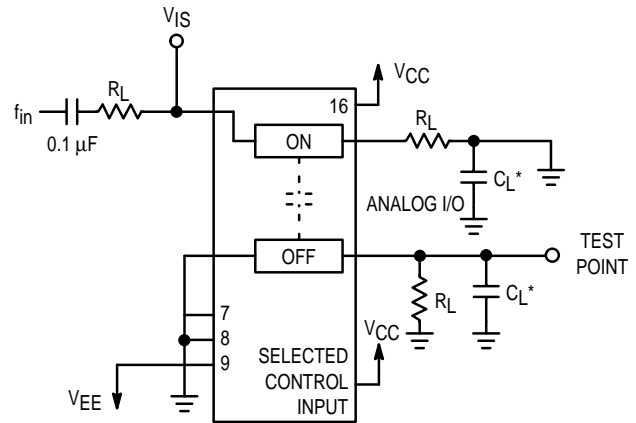

Figure 10. Propagation Delay, ON/OFF Control to Analog Out



*Includes all probe and jig capacitance.

Figure 11. Propagation Delay Test Set-Up



*Includes all probe and jig capacitance.

Figure 12. Crosstalk Between Any Two Switches, Test Set-Up (Adjacent Channels Used)

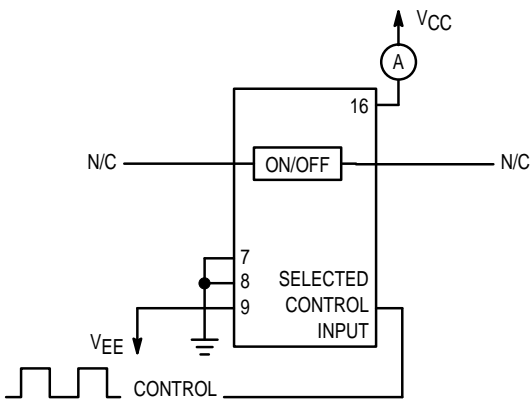
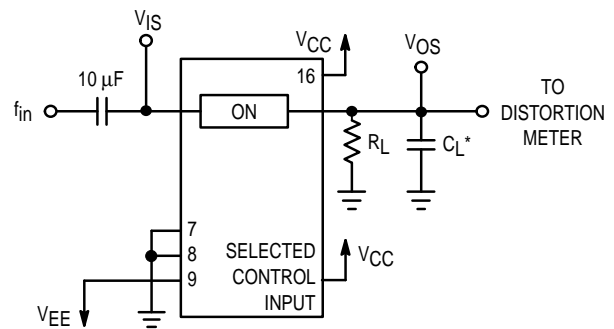

Figure 13. Power Dissipation Capacitance Test Set-Up



*Includes all probe and jig capacitance.

Figure 14. Total Harmonic Distortion, Test Set-Up

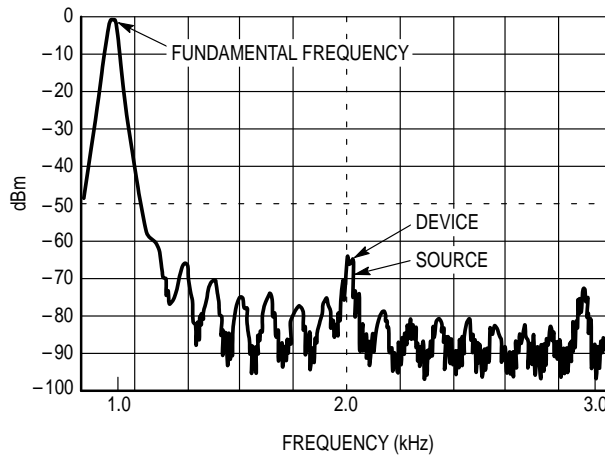

Figure 15. Plot, Harmonic Distortion

APPLICATION INFORMATION

The Enable and Control pins should be at V_{CC} or GND logic levels, V_{CC} being recognized as logic high and GND being recognized as a logic low. Unused analog inputs/outputs may be left floating (not connected). However, it is advisable to tie unused analog inputs and outputs to V_{CC} or V_{EE} through a low value resistor. This minimizes crosstalk and feedthrough noise that may be picked up by the unused I/O pins.

The maximum analog voltage swings are determined by the supply voltages V_{CC} and V_{EE} . The positive peak analog voltage should not exceed V_{CC} . Similarly, the negative peak analog voltage should not go below V_{EE} . In the example

below, the difference between V_{CC} and V_{EE} is twelve volts. Therefore, using the configuration in Figure 16, a maximum analog signal of twelve volts peak-to-peak can be controlled.

When voltage transients above V_{CC} and/or below V_{EE} are anticipated on the analog channels, external diodes (D_x) are recommended as shown in Figure 17. These diodes should be small signal, fast turn-on types able to absorb the maximum anticipated current surges during clipping. An alternate method would be to replace the D_x diodes with MO•sorbs (Motorola high current surge protectors). MO•sorbs are fast turn-on devices ideally suited for precise dc protection with no inherent wear out mechanism.

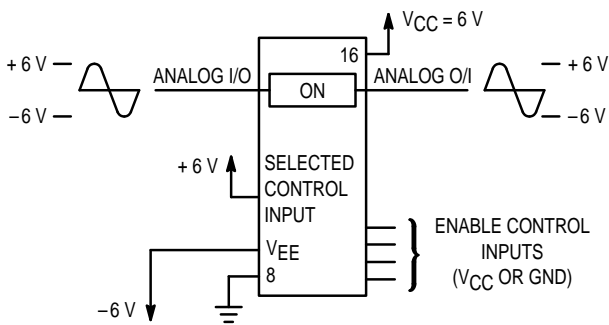

Figure 16.

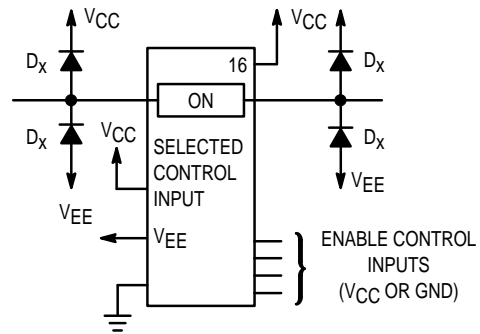

Figure 17. Transient Suppressor Application

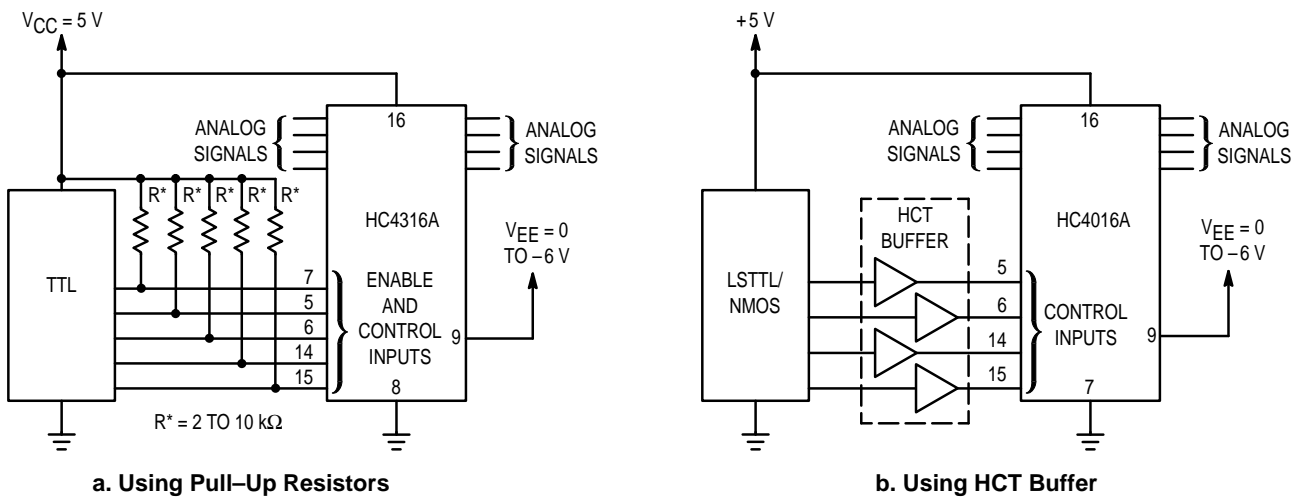

Figure 18. LSTTL/NMOS to HCMOS Interface

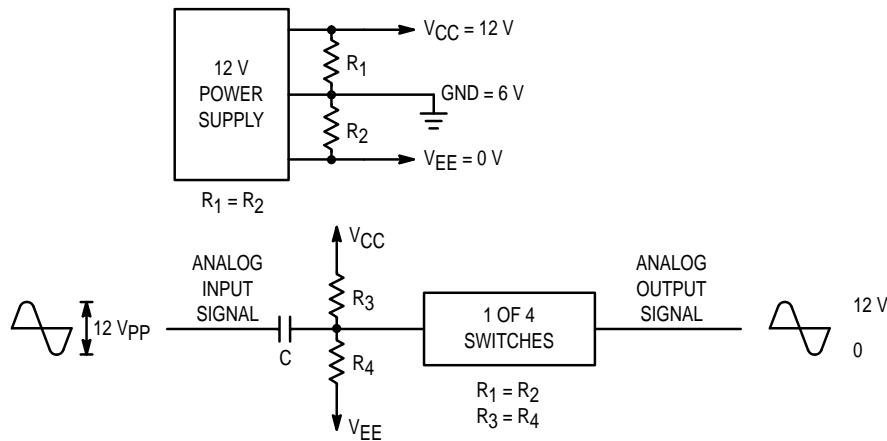

Figure 19. Switching a 0-to-12 V Signal Using a Single Power Supply ($GND \neq 0 V$)

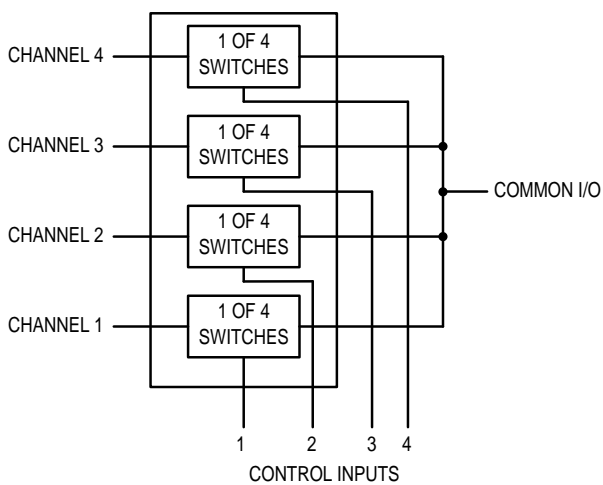

Figure 20. 4-Input Multiplexer

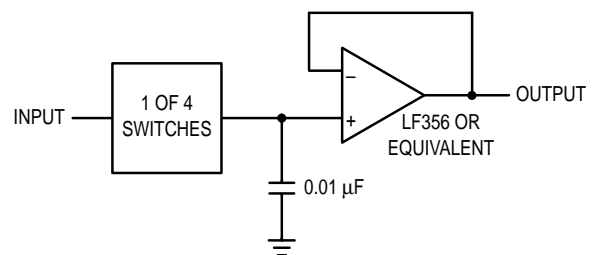
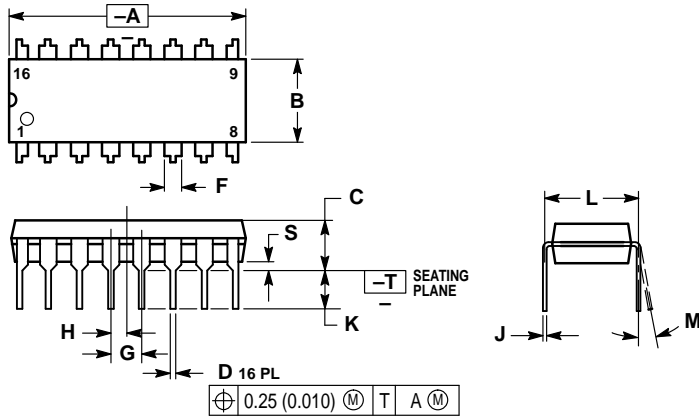

Figure 21. Sample/Hold Amplifier

OUTLINE DIMENSIONS

N SUFFIX
PLASTIC PACKAGE
CASE 648-08
ISSUE R



- NOTES:
1. DIMENSIONING AND TOLERANCING PER ANSI Y14.5M, 1982.
 2. CONTROLLING DIMENSION: INCH.
 3. DIMENSION L TO CENTER OF LEADS WHEN FORMED PARALLEL.
 4. DIMENSION B DOES NOT INCLUDE MOLD FLASH.
 5. ROUNDED CORNERS OPTIONAL.

DIM	INCHES		MILLIMETERS	
	MIN	MAX	MIN	MAX
A	0.740	0.770	18.80	19.55
B	0.250	0.270	6.35	6.85
C	0.145	0.175	3.69	4.44
D	0.015	0.021	0.39	0.53
F	0.040	0.070	1.02	1.77
G	0.100 BSC		2.54 BSC	
H	0.050 BSC		1.27 BSC	
J	0.008	0.015	0.21	0.38
K	0.110	0.130	2.80	3.30
L	0.295	0.305	7.50	7.74
M	0°	10°	0°	10°
S	0.020	0.040	0.51	1.01

D SUFFIX
PLASTIC SOIC PACKAGE
CASE 751B-05
ISSUE J

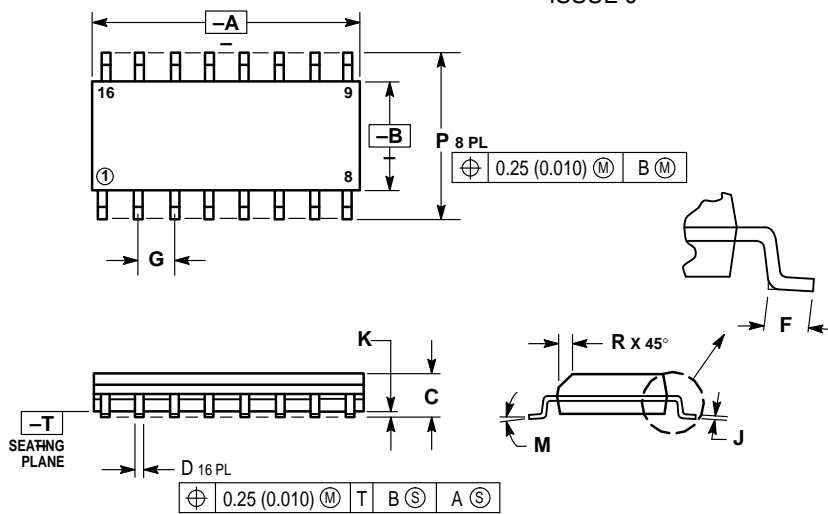

- NOTES:
1. DIMENSIONING AND TOLERANCING PER ANSI Y14.5M, 1982.
 2. CONTROLLING DIMENSION: MILLIMETER.
 3. DIMENSIONS A AND B DO NOT INCLUDE MOLD PROTRUSION.
 4. MAXIMUM MOLD PROTRUSION 0.15 (0.006) PER SIDE.
 5. DIMENSION D DOES NOT INCLUDE DAMBAR PROTRUSION. ALLOWABLE DAMBAR PROTRUSION SHALL BE 0.127 (0.005) TOTAL IN EXCESS OF THE D DIMENSION AT MAXIMUM MATERIAL CONDITION.

DIM	MILLIMETERS		INCHES	
	MIN	MAX	MIN	MAX
A	9.80	10.00	0.386	0.393
B	3.80	4.00	0.150	0.157
C	1.35	1.75	0.054	0.068
D	0.35	0.49	0.014	0.019
F	0.40	1.25	0.016	0.049
G	1.27 BSC		0.060 BSC	
J	0.19	0.25	0.008	0.009
K	0.10	0.25	0.004	0.009
M	0°	7°	0°	7°
P	5.80	6.20	0.229	0.244
R	0.25	0.50	0.010	0.019

OUTLINE DIMENSIONS

DT SUFFIX
TSSOP PACKAGE
CASE 948G-01
ISSUE O

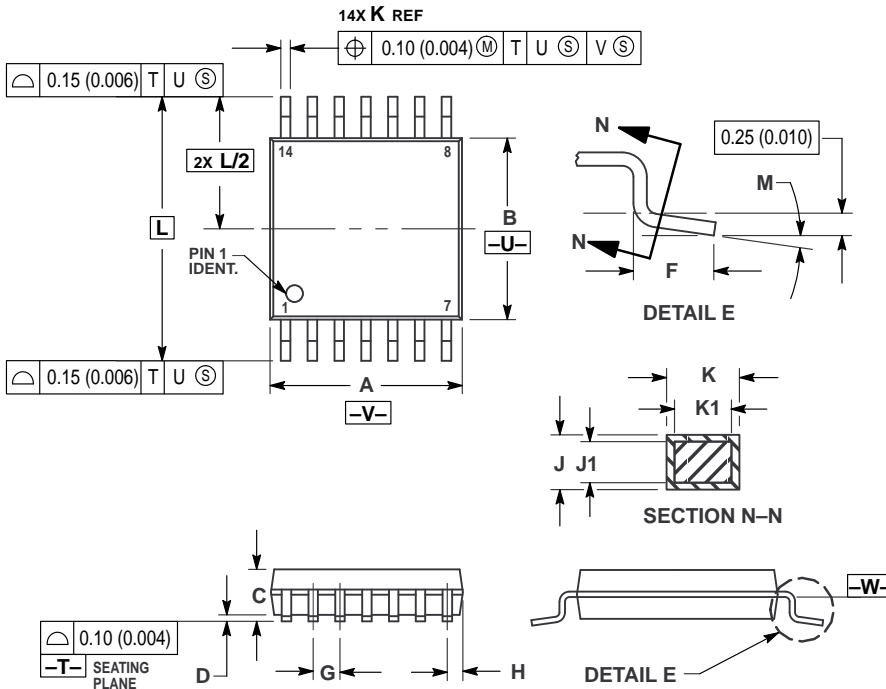

- NOTES:
1. DIMENSIONING AND TOLERANCING PER ANSI Y14.5M, 1982.
 2. CONTROLLING DIMENSION: MILLIMETER.
 3. DIMENSION A DOES NOT INCLUDE MOLD FLASH, PROTRUSIONS OR GATE BURRS. MOLD FLASH OR GATE BURRS SHALL NOT EXCEED 0.15 (0.006) PER SIDE.
 4. DIMENSION B DOES NOT INCLUDE INTERLEAD FLASH OR PROTRUSION. INTERLEAD FLASH OR PROTRUSION SHALL NOT EXCEED 0.25 (0.010) PER SIDE.
 5. DIMENSION K DOES NOT INCLUDE DAMBAR PROTRUSION. ALLOWABLE DAMBAR PROTRUSION SHALL BE 0.08 (0.003) TOTAL IN EXCESS OF THE K DIMENSION AT MAXIMUM MATERIAL CONDITION.
 6. TERMINAL NUMBERS ARE SHOWN FOR REFERENCE ONLY.
 7. DIMENSION A AND B ARE TO BE DETERMINED AT DATUM PLANE -W-.

DIM	MILLIMETERS		INCHES	
	MIN	MAX	MIN	MAX
A	4.90	5.10	0.193	0.200
B	4.30	4.50	0.169	0.177
C	—	1.20	—	0.047
D	0.05	0.15	0.002	0.006
F	0.50	0.75	0.020	0.030
G	0.65 BSC		0.026 BSC	
H	0.50	0.60	0.020	0.024
J	0.09	0.20	0.004	0.008
J1	0.09	0.16	0.004	0.006
K	0.19	0.30	0.007	0.012
K1	0.19	0.25	0.007	0.010
L	6.40 BSC		0.252 BSC	
M	0°	8°	0°	8°

Motorola reserves the right to make changes without further notice to any products herein. Motorola makes no warranty, representation or guarantee regarding the suitability of its products for any particular purpose, nor does Motorola assume any liability arising out of the application or use of any product or circuit, and specifically disclaims any and all liability, including without limitation consequential or incidental damages. "Typical" parameters can and do vary in different applications. All operating parameters, including "Typicals" must be validated for each customer application by customer's technical experts. Motorola does not convey any license under its patent rights nor the rights of others. Motorola products are not designed, intended, or authorized for use as components in systems intended for surgical implant into the body, or other applications intended to support or sustain life, or for any other application in which the failure of the Motorola product could create a situation where personal injury or death may occur. Should Buyer purchase or use Motorola products for any such unintended or unauthorized application, Buyer shall indemnify and hold Motorola and its officers, employees, subsidiaries, affiliates, and distributors harmless against all claims, costs, damages, and expenses, and reasonable attorney fees arising out of, directly or indirectly, any claim of personal injury or death associated with such unintended or unauthorized use, even if such claim alleges that Motorola was negligent regarding the design or manufacture of the part. Motorola and are registered trademarks of Motorola, Inc. Motorola, Inc. is an Equal Opportunity/Affirmative Action Employer.

How to reach us:

USA/EUROPE: Motorola Literature Distribution;
P.O. Box 20912; Phoenix, Arizona 85036. 1-800-441-2447

JAPAN: Nippon Motorola Ltd.; Tatsumi-SPD-JLDC, Toshikatsu Otsuki,
6F Seibu-Butsuryu-Center, 3-14-2 Tatsumi Koto-Ku, Tokyo 135, Japan. 03-3521-8315

MFAX: RMFAX0@email.sps.mot.com -TOUCHTONE (602) 244-6609
INTERNET: http://Design-NET.com

HONG KONG: Motorola Semiconductors H.K. Ltd.; 8B Tai Ping Industrial Park,
51 Ting Kok Road, Tai Po, N.T., Hong Kong. 852-26629298



CODELINE

MC74HC4316A/D

