



Micromachined Accelerometer

The XMMA series of silicon capacitive, micromachined accelerometers features; signal conditioning, a 4-pole low pass filter and temperature compensation. Zero-g offset full scale span and filter cut-off are factory set and require no external devices. A full system self-test capability verifies system functionality.

The XMMA series of accelerometers is suitable for automotive crash detection and recording, vibration monitoring, automotive suspension control, appliance control systems, etc.

Features

- Minimum Full Scale Measurement $\pm 44g$
- Calibrated, Self-Test
- Integral Signal Conditioning and 4-Pole Filter
- Linear Output
- Robust, High Shock Survivability
- Ratiometric
- G-Cell, Hermetically Sealed at Wafer Level
- Two Packaging Options Available:
 - 1) Plastic DIP for Z Axis Sensing (XMMA1000P)
 - 2) Wingback for X Axis Sensing (XMMA2000W)

Typical Applications

- Automotive Crash Detection and Recording
- Automotive Suspension Control
- Vibration Monitoring and Recording
- Appliance Control
- Mechanical Bearing Monitoring
- Computer Hard Drive Protection
- Computer Mouse and Joysticks
- Virtual Reality Input Devices
- Sports Diagnostic Devices and Systems

XMMA1000P
XMMA2000W

XMMA1000: Z AXIS SENSITIVITY
XMMA2000: X AXIS SENSITIVITY
MICROMACHINED
ACCELEROMETER
 $\pm 50g$

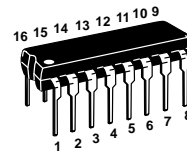

DIP PACKAGE
CASE 648C-03
XMMA1000P

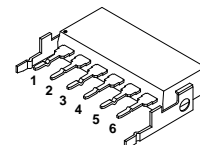

WB PACKAGE
CASE 456-03
XMMA2000W

SIMPLIFIED ACCELEROMETER FUNCTIONAL BLOCK DIAGRAM

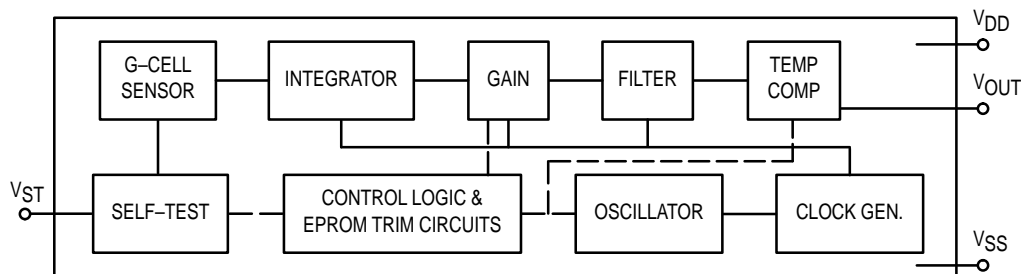

Senseon is a trademark of Motorola, Inc.

Replaces MMA1000P/D

XMMA1000P XMMA2000W

MAXIMUM RATINGS (Maximum ratings are the limits to which the device can be exposed without causing permanent damage.)

Rating	Symbol	Value	Unit
Powered Acceleration (all axis)	G_{pd}	500	g
Unpowered Acceleration (all axis)	G_{upd}	2000	g
Supply Voltage	V_{DD}	-0.3 to +7.0	V
Drop Test ⁽¹⁾	D_{drop}	1.2	m
Storage Temperature Range	T_{stg}	-40 to +105	°C

OPERATING RANGE (These limits define the range of operation for which the part will meet specification.)

Characteristic	Symbol	Min	Typ	Max	Unit
Supply Voltage ⁽²⁾	V_{DD}	4.75	5.0	5.25	V
Supply Current	I_{DD}	1.0	4.0	5.0	mA
Operating Temperature Range	T_A	-40	—	+85	°C

NOTES:

1. Dropped onto concrete surface from any axis.
2. Within the supply range of 4.75 and 5.25 volts, the device operates as a fully calibrated linear accelerometer. Beyond these supply limits the device may operate as a linear device but is not guaranteed to be in calibration.

ELECTRO STATIC DISCHARGE (ESD)

Due to the technological advancing semiconductor industry, it has now become increasingly important for semiconductor manufacturers, users of semiconductors and other electronic components to fully understand the nature and sources of ESD. More importantly, a thorough understanding of its impact on quality and reliability must be understood.

Whereas the Motorola accelerometers contain internal 2kV ESD protection circuitry, extra precaution must be taken by the user to protect the chip from ESD. A charge of over 2000 volts can accumulate on the human body or associated Automated Test Equipment (ATE). A charge of this magnitude can alter the performance or cause failure of the chip. When proper ESD precautions are followed the discharges will not be detrimental to the chips performance.

FREQUENTLY ASKED QUESTIONS

Q. What is the g-cell?

A. The g-cell is the acceleration transducer within the accelerometer device. It is hermetically sealed at the wafer level to ensure a contaminant free environment, resulting in superior reliability performance.

Q. What does the output typically interface with?

A. The accelerometer device is designed to interface with an analog to digital converter available on most microcontrollers. The output has a 2.5 V DC offset, therefore positive and negative acceleration is measurable.

Q. What is the orientation of the g-force in relation to the output voltage?

A. The accelerometer responds to g forces perpendicular to the plane of the package. For acceleration directed onto the top of the package, the output voltage will increase above the nominal 2.5 V. For acceleration directed away from the top of the package, the output will decrease below 2.5 V. Refer to the "Positive Acceleration Sensing Direction" diagram on page 7.

Q. What is the resonant frequency of the g-cell?

A. The accelerometer's g-cell is overdamped. The first resonant mode of the package is 10 kHz for the DIP and 5 kHz for the Wingback.

Q. What is ratiometricity?

A. Ratiometricity is the sensors ability to track changes in supply voltage. This is a key feature when interfacing to a microcontroller or an A/D converter. Ratiometricity allows for system level cancellation of supply induced errors in the analog to digital conversion process. Refer to the Special Features section under the Principle of Operation for more information.

Q. Is the accelerometer device sensitive to electrostatic discharge (ESD)?

A. Yes . . . the SENSEON accelerometer should be handled like other CMOS technology devices.

Q. Can the g-cell part "latch"?

A. No, overrange stops have been designed into the g-cell to prevent latching. (Latching is when the middle plate of the g-cell sticks to either the upper or lower plate.)

OPERATING CHARACTERISTICS

 (Unless otherwise noted: $-40^{\circ} \leq T_A \leq +85^{\circ}$, $4.75 \leq V_{DD} \leq 5.25$, Acceleration = 0g, Loaded output⁽¹⁾)

Characteristic	Symbol	Min	Typ	Max	Unit
Sensitivity ($T_A = 25^{\circ}\text{C}$, $V_{DD} = 5.0\text{ V}$) ⁽²⁾	ΔS	37.2	40	42.8	mV/g
Sensitivity ⁽²⁾	ΔS	7.36	8.0	8.64	mV/V/g
Zero Accel Output ⁽³⁾ ($V_{DD} = 5.0\text{ V}$)	V_{OFF}	2.2	2.5	2.8	V
Zero Accel Output	V_{OFF}	$0.44 V_{DD}$	$0.5 V_{DD}$	$0.56 V_{DD}$	V
Acceleration Range ⁽⁴⁾	G	44	50	—	g
Noise (10 Hz to 400 Hz) ⁽⁵⁾	V_N	—	—	3.5	mVrms
Clock Noise ⁽⁶⁾	V_{NC}	—	2.0	—	mVpk
Filter Cut Off Frequency	F_{-3dB}	360	400	440	Hz
Self-Test Output Response	G_{ST}	20	25	30	g
Self-Test Input Low	V_{IL}	—	—	1.4	V
Self-Test Input High	V_{IH}	3.7	—	—	V
Self-Test Input Loading ⁽⁷⁾	I_{IN}	30	60	120	μA
Self-Test Response Time ⁽⁸⁾	t_{ST}	—	2.0	—	ms
Electrical Saturation Recovery Time ⁽⁹⁾	—	—	0.2	—	ms
Full Scale Output Range ($I_{OUT} = 200\ \mu\text{A}$)	V_{FSO}	0.3	—	$V_{DD} - 0.3$	V
Capacitive Load Drive ⁽¹⁰⁾	C_L	—	—	100	pF
Output Impedance	Z_O	—	300	—	Ω
Nonlinearity	—	—	1.0	—	% FSO
Alignment Error	—	—	± 3.0	—	degrees
Transverse Sensitivity ⁽¹¹⁾	—	—	3.0	—	% FSO
Package Resonance (DIP/WB)	—	—	10/5	—	kHz

NOTES:

- For a loaded output the measurements are observed after an RC filter consisting of a 1 k Ω resistor and a 0.01 μF capacitor to ground.
- The device is calibrated at 20g.
- The device can measure both + and – acceleration. With no input acceleration the output is at midsupply. For positive acceleration the output will increase above $V_{DD}/2$ and for negative acceleration the output will decrease below $V_{DD}/2$.
- Refer to the Principle of Operation section for a sample g range calculation.
- Refer to the Principle of Operation section for a sample rms to peak to peak calculation.
- At clock frequency $\cong 65\text{ kHz}$.
- The digital input pin has an internal pull-down current source to prevent inadvertent self test initiation due to external board level leakages.
- Time for the output to reach 90% of its final value after a self-test is initiated.
- Time for amplifiers to recover after an acceleration signal causing them to saturate.
- Preserves phase margin (60 $^{\circ}$) to guarantee output amplifier stability.
- A measure of the devices ability to reject an acceleration applied 90 $^{\circ}$ from the true axis of sensitivity.

XMMA1000P XMMA2000W

Pinout description for the Wingback package:

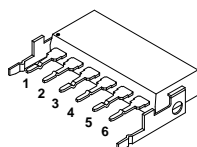

Pin #	Pin Name	Description
1	—	No internal connection, tie to V_{SS}
2	ST	Logic input pin to initiate self test
3	V_{OUT}	Output voltage
4	—	No internal connection, tie to V_{SS}
5	V_{SS}	Signal ground
6	V_{DD}	Supply voltage (5 V)
—	Wings	Support pins, internally connected to lead frame. Tie to V_{SS} .

Pinout description for the DIP package:

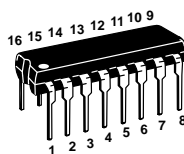

Pin #	Pin Name	Description
1	—	No internal connection, tie to V_{SS}
2	—	No internal connection, tie to V_{SS}
3	—	No internal connection, tie to V_{SS}
4	ST	Logic input pin to initiate self test
5	V_{OUT}	Output voltage
6	—	No internal connection, tie to V_{SS}
7	V_{SS}	Signal ground
8	V_{DD}	Supply voltage (5 V)
9	Trim 1	Used for factory trim, tie to V_{SS}
10	Trim 2	Used for factory trim, tie to V_{SS}
11	Trim 3	Used for factory trim, MUST tie to V_{DD}
12	Trim 4	Used for factory trim, tie to V_{SS}
13	Trim 5	Used for factory trim, tie to V_{SS}
14	—	No internal connection, tie to V_{SS}
15	—	No internal connection, tie to V_{SS}
16	—	No internal connection, tie to V_{SS}

PRINCIPLE OF OPERATION

The Motorola accelerometer is a surface-micromachined integrated-circuit accelerometer.

The device consists of a surface micromachined capacitive sensing cell (G-cell) and a CMOS signal conditioning ASIC contained in a single integrated circuit package. The sensing element is sealed hermetically at the wafer level using a bulk micromachined "cap" wafer.

The G-Cell is a mechanical structure formed from semiconductor materials (polysilicon) using semiconductor processes (masking and etching). It consists of two stationary plates with a moveable plate in-between. The center plate can be deflected from its rest position by subjecting the system to an acceleration (Figure 1).

When the center plate deflects, the distance from it to one fixed plate will increase by the same amount that the distance to the other plate decreases. The change in distance is a measure of acceleration.

The G-Cell plates form two back-to-back capacitors (Figure 2). As the center plate moves with acceleration, the distance between the plates changes and each capacitor's value will change, ($C = A\epsilon/D$). Where A is the area of the plate, ϵ is the dielectric constant, and D is the distance between the plates.

The CMOS ASIC uses switched capacitor techniques to measure the G-Cell capacitors and extract the acceleration data from the difference between the two capacitors. The ASIC also signal conditions and filters (switched capacitor) the signal, providing a high level output voltage that is ratio-metric and proportional to acceleration.

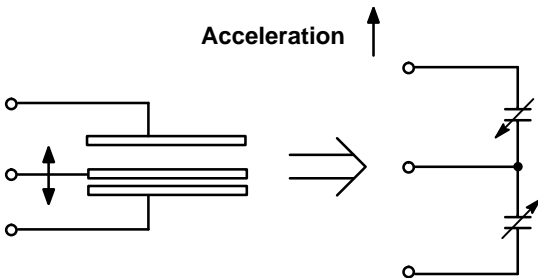

Figure 1.

Figure 2.

SPECIAL FEATURES

Filtering

The Motorola accelerometers contain an onboard 4-pole switched capacitor filter. A Bessel implementation is used because it provides a maximally flat delay response (linear phase) thus preserving pulse shape integrity. Because the filter is realized using switched capacitor techniques, there is no requirement for external passive components (resistors and capacitors) to set the cut-off frequency.

Noise Calculation

The noise for the Motorola accelerometer is specified as an rms value which is a statistical value of a gaussian noise source. To convert the rms values to a peak to peak value at a particular confidence level refer to Table 1. A sample calculation at a 99.9% confidence level is shown.

Table 1.

Nominal Peak to Peak Value	% Confidence Level
2.0 × rms	68%
3.0 × rms	87%
4.0 × rms	95.40%
5.0 × rms	98.80%
6.0 × rms	99.73%
6.6 × rms	99.90%

Noise rms = 3.5mVrms

Noise peak to peak at a 99.9% confidence level:
3.5mVrms * 6.6 = 23.1mVpp

Self-Test

XMMA sensors provide a self-test feature that allows the verification of the mechanical and electrical integrity of the accelerometer at any time before or after installation. This feature is critical in applications such as automotive airbag systems where system integrity must be ensured over the life of the vehicle. A fourth "plate" is used in the g-cell as a self-test plate. This plate is fixed and is located under an extended portion of the center (moveable) plate. When the user applies a logic high input to the self-test pin, a calibrated potential is applied across the self-test plate and the moveable plate. The resulting electrostatic force ($F_e = 1/2 AV^2/d^2$) causes the center plate to deflect. The resultant deflection, is measured by the accelerometer's control ASIC and a proportional output voltage results. This procedure assures that both the mechanical (g-cell) and electronic sections of the sensor are functioning.

Ratiometricity

The XMMA1000P and XMMA2000W are designed to be "ratiometric". That is, their transfer function will be proportional to the applied supply voltage. This feature allows easy interfacing to common microcontrollers that use ratiometric A/D converters for system cost benefits.

In operation, a ratiometric sensor's gain or "sensitivity" will change 1:1 with applied supply voltage and the zero signal output will be at midsupply. (2.5 V for a 5 V V_{DD} and 2.625 V for a 5.25 V_{DD}).

Minimum G Range Calculation

To calculate the minimum g range values of an accelerometer several factors have to be taken into consideration. These considerations include, the supply voltage, the device's sensitivity, offset voltage and output rail. A sample calculation for the minimum g range is shown below.

To complete the calculation the rail and offset voltages must be subtracted from the supply voltage, then divided by the supply voltage multiplied by the device's worst case (highest) sensitivity.

$$\frac{V_{DD} - 0.56V_{DD} - 0.3V}{V_{DD}(8.64mV/V/g)} = \frac{0.44V_{DD} - 0.3V}{V_{DD}(0.00864)} = \left(50.93 - \frac{34.72}{V_{DD}} \right)g$$

Using the standard five volt power supply, the minimum g range is calculated to be:

$$50.926 - \frac{34.722}{5.00} = 43.98 \approx 44g$$

XMMA1000P XMMA2000W

BASIC CONNECTIONS

Circuit Schematic

Figure 3 shows the recommended connection diagram for operating the accelerometer. Figure 3 (a) shows the 16 pin DIP package version, the XMMA1000P, while (b) shows the 6 pin Wingback package version, the XMMA2000W. For the XMMA1000P, pins 1, 2, 3, 6, 14, 15, and 16 have no internal connections, and pins 9 through 13 are used for calibration and trimming in the factory. These pins should all be connected to V_{SS} , except pin 11 which must be connected to V_{DD} . For the XMMA2000W, pins 1 and 4, and the wings (supporting pins) should be connected to V_{SS} .

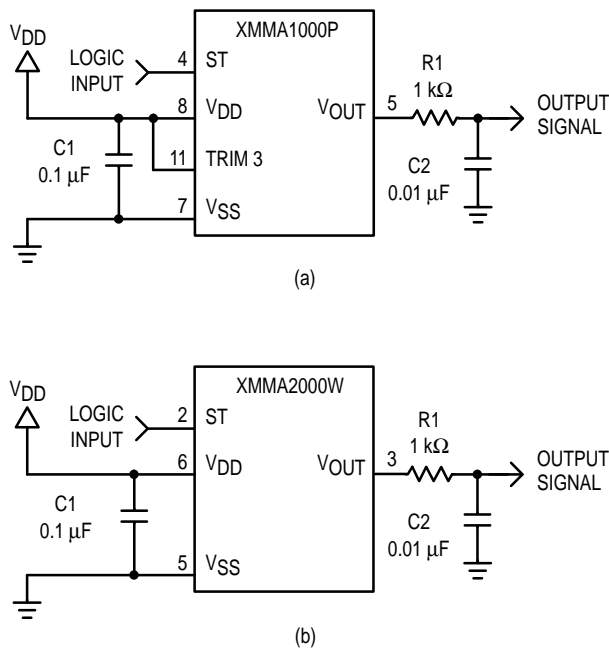
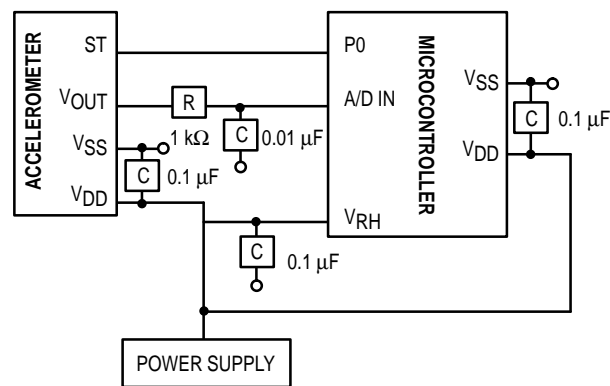



Figure 3. Accelerometers with Recommended Connection Diagram

PCB Layout



NOTES:

- Use a .1 μF capacitor on V_{DD} to decouple the power source.
- Physical coupling distance of the accelerometer to the microcontroller should be minimal.
- Place a ground plane beneath the accelerometer to reduce noise, the ground plane should be attached to all of the open ended terminals shown above.
- Use independent supply traces for the A/D reference (microcontroller) and the accelerometer.
- Use an RC filter of 1 $\text{k}\Omega$ and 0.01 μF on the output of the accelerometer to minimize induced errors.
- PCB layout of power and ground should not couple power supply noise.
- Accelerometer and microcontroller should not be a high current path.
- For ratiometricity purposes the accelerometer V_{DD} and microcontroller A/D reference pin should be on the same trace.
- A/D sampling rate and any external power supply switching frequency should be selected such that they do not interfere with the internal accelerometer sampling frequency. This will prevent aliasing errors.

Motorola reserves the right to make changes without further notice to any products herein. Motorola makes no warranty, representation or guarantee regarding the suitability of its products for any particular purpose, nor does Motorola assume any liability arising out of the application or use of any product or circuit, and specifically disclaims any and all liability, including without limitation consequential or incidental damages. "Typical" parameters which may be provided in Motorola data sheets and/or specifications can and do vary in different applications and actual performance may vary over time. All operating parameters, including "Typicals" must be validated for each customer application by customer's technical experts. Motorola does not convey any license under its patent rights nor the rights of others. Motorola products are not designed, intended, or authorized for use as components in systems intended for surgical implant into the body, or other applications intended to support or sustain life, or for any other application in which the failure of the Motorola product could create a situation where personal injury or death may occur. Should Buyer purchase or use Motorola products for any such unintended or unauthorized application, Buyer shall indemnify and hold Motorola and its officers, employees, subsidiaries, affiliates, and distributors harmless against all claims, costs, damages, and expenses, and reasonable attorney fees arising out of, directly or indirectly, any claim of personal injury or death associated with such unintended or unauthorized use, even if such claim alleges that Motorola was negligent regarding the design or manufacture of the part. Motorola and  are registered trademarks of Motorola, Inc. Motorola, Inc. is an Equal Opportunity/Affirmative Action Employer.

Positive Acceleration Sensing Direction

DIP PACKAGE

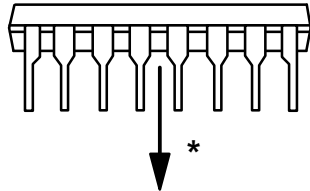
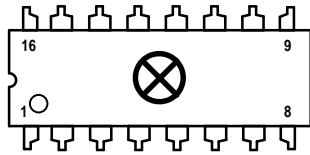

WINGBACK PACKAGE

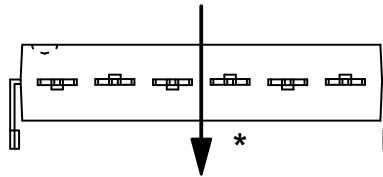
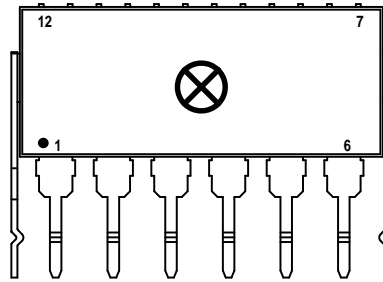

* When positioned as shown, the Earth's gravity will result in a positive 1g output

Drilling Patterns

WB PACKAGE DRILLING PATTERN

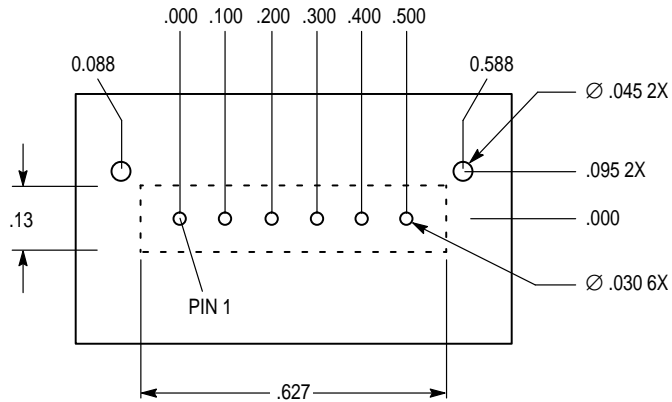

Measurement in inches

ORDERING INFORMATION

Device	Temperature Range	Case No.	Package
XMMA1000P	-40 to +85°C	Case 648C-03	Plastic DIP
XMMA2000W	-40 to +85°C	Case 456-03	Plastic Wingback

PACKAGE DIMENSIONS

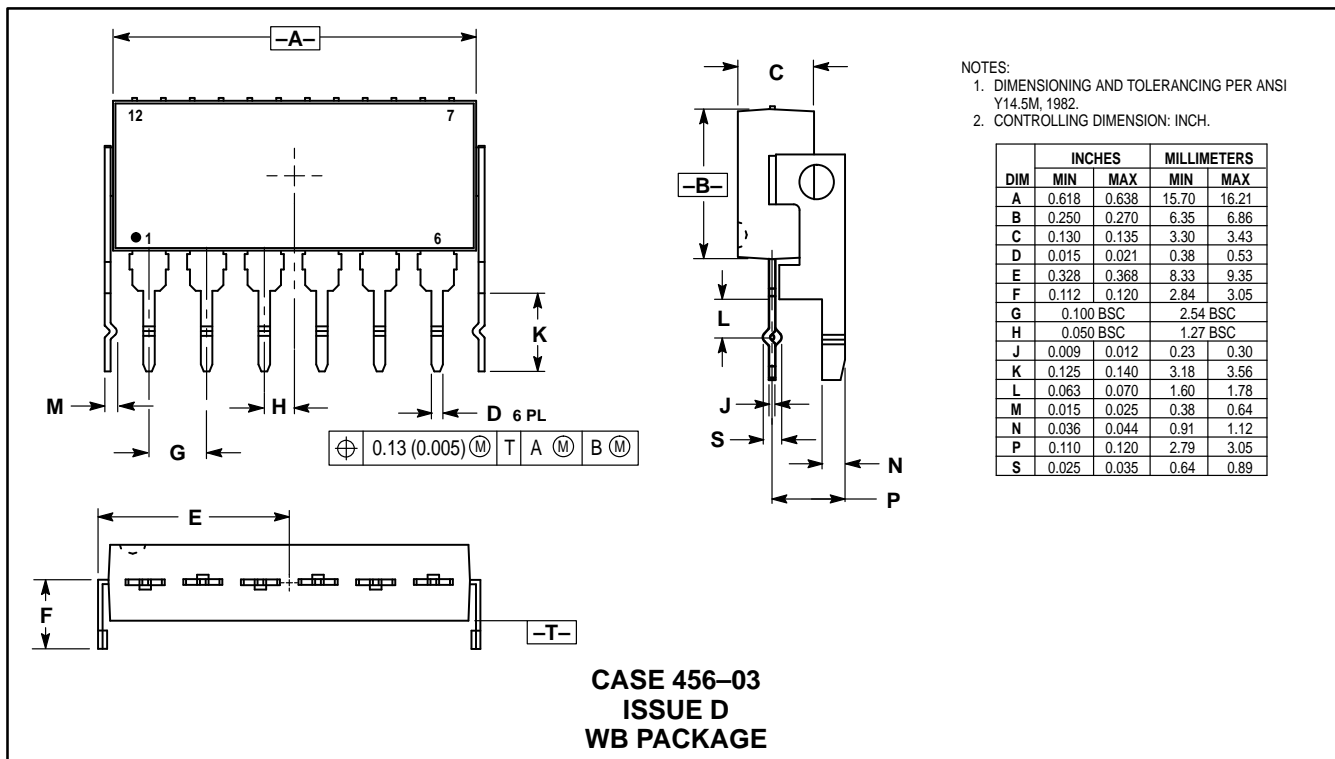
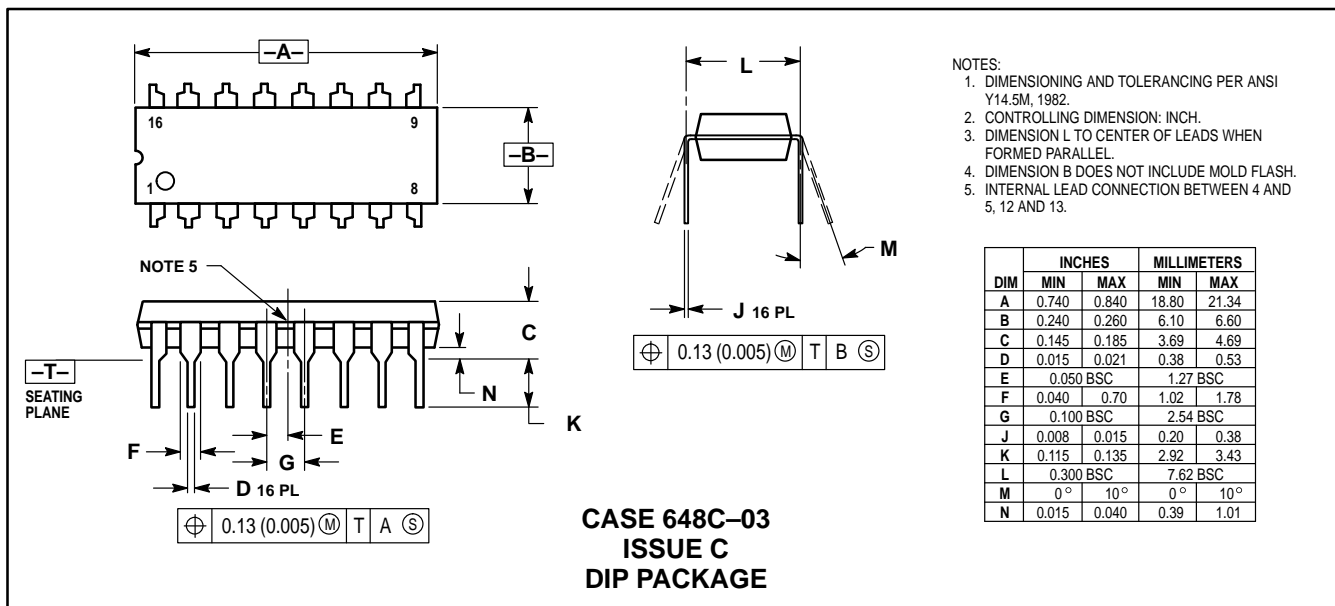

Mfax is a trademark of Motorola, Inc.

How to reach us:

USA/EUROPE/Locations Not Listed: Motorola Literature Distribution;
P.O. Box 5405, Denver, Colorado 80217. 1-303-675-2140 or 1-800-441-2447

JAPAN: Nippon Motorola Ltd.: SPD, Strategic Planning Office, 4-32-1,
Nishi-Gotanda, Shinagawa-ku, Tokyo 141, Japan. 81-3-5487-8488

Customer Focus Center: 1-800-521-6274

Mfax™: RMFAX0@email.sps.mot.com – TOUCHTONE 1-602-244-6609
Motorola Fax Back System – US & Canada ONLY 1-800-774-1848
– http://sps.motorola.com/mfax/

ASIA/PACIFIC: Motorola Semiconductors H.K. Ltd.; 8B Tai Ping Industrial Park,
51 Ting Kok Road, Tai Po, N.T., Hong Kong. 852-26629298

HOME PAGE: http://motorola.com/sps/

