

Product Preview
Medium Power Surface Mount Products
TMOS Single P-Channel
Field Effect Transistors

WaveFET™ devices are an advanced series of power MOSFETs which utilize Motorola's High Cell Density HDTMOS process. These miniature surface mount MOSFETs feature ultra low $R_{DS(on)}$ and true logic level performance. They are capable of withstanding high energy in the avalanche and commutation modes and the drain-to-source diode has a very low reverse recovery time. WaveFET™ devices are designed for use in low voltage, high speed switching applications where power efficiency is important. Typical applications are dc-dc converters, and power management in portable and battery powered products such as computers, printers, cellular and cordless phones. They can also be used for low voltage motor controls in mass storage products such as disk drives and tape drives. The avalanche energy is specified to eliminate the guesswork in designs where inductive loads are switched and offer additional safety margin against unexpected voltage transients.

- Ultra Low $R_{DS(on)}$ Provides Higher Efficiency and Extends Battery Life
- Logic Level Gate Drive — Can Be Driven by Logic ICs
- Miniature SO-8 Surface Mount Package — Saves Board Space
- Diode Is Characterized for Use In Bridge Circuits
- Diode Exhibits High Speed, With Soft Recovery
- I_{DSS} Specified at Elevated Temperature
- Avalanche Energy Specified
- Mounting Information for SO-8 Package Provided

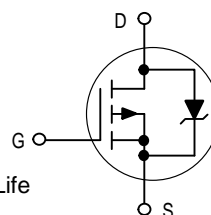

MMSF3305

Motorola Preferred Device

**SINGLE TMOS
POWER MOSFET**
9.1 AMPERES
30 VOLTS
 $R_{DS(on)} = 0.02 \text{ OHM}$



CASE 751-05, Style 13
SO-8

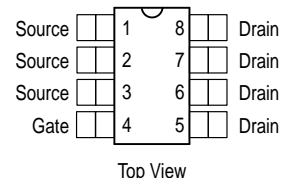

DEVICE MARKING

ORDERING INFORMATION

S3305	Device	Reel Size	Tape Width	Quantity
	MMSF3305R2	13"	12 mm embossed tape	4000 units

Preferred devices are Motorola recommended choices for future use and best overall value.

This document contains information on a product under development. Motorola reserves the right to change or discontinue this product without notice.

HDTMOS and WaveFET are trademarks of Motorola, Inc. TMOS is a registered trademark of Motorola, Inc.

MMSF3305

MAXIMUM RATINGS ($T_J = 25^\circ\text{C}$ unless otherwise noted)

Negative sign for P-Channel devices omitted for clarity

Rating		Symbol	Max	Unit
Drain-to-Source Voltage		V_{DSS}	30	V
Drain-to-Gate Voltage ($R_{GS} = 1.0\text{ M}\Omega$)		V_{DGR}	20	V
Gate-to-Source Voltage — Continuous		V_{GS}	± 20	V
1 inch SQ. FR-4 or G-10 PCB 10 seconds	Thermal Resistance — Junction to Ambient	R_{THJA}	50	$^\circ\text{C/W}$
	Total Power Dissipation @ $T_A = 25^\circ\text{C}$	P_D	2.5	Watts
	Linear Derating Factor		20	$\text{mW}/^\circ\text{C}$
	Drain Current — Continuous @ $T_A = 25^\circ\text{C}$	I_D	9.1	A
	Continuous @ $T_A = 70^\circ\text{C}$	I_D	7.3	A
	Pulsed Drain Current (1)	I_{DM}	50	A
Minimum FR-4 or G-10 PCB 10 seconds	Thermal Resistance — Junction to Ambient	R_{THJA}	80	$^\circ\text{C/W}$
	Total Power Dissipation @ $T_A = 25^\circ\text{C}$	P_D	1.56	Watts
	Linear Derating Factor		12.5	$\text{mW}/^\circ\text{C}$
	Drain Current — Continuous @ $T_A = 25^\circ\text{C}$	I_D	7.2	A
	Continuous @ $T_A = 70^\circ\text{C}$	I_D	5.8	A
	Pulsed Drain Current (1)	I_{DM}	40	A
Operating and Storage Temperature Range		T_J, T_{stg}	- 55 to 150	$^\circ\text{C}$
Single Pulse Drain-to-Source Avalanche Energy — Starting $T_J = 25^\circ\text{C}$ ($V_{DD} = 30\text{ Vdc}$, $V_{GS} = 10\text{ Vdc}$, Peak $I_L = 9.1\text{ Apk}$, $L = \text{TBD mH}$, $R_G = 25\ \Omega$)		E_{AS}	TBD	mJ

(1) Repetitive rating; pulse width limited by maximum junction temperature.

ELECTRICAL CHARACTERISTICS ($T_C = 25^\circ\text{C}$ unless otherwise noted)

Characteristic	Symbol	Min	Typ	Max	Unit
----------------	--------	-----	-----	-----	------

OFF CHARACTERISTICS

Drain-to-Source Breakdown Voltage ($V_{GS} = 0\text{ Vdc}$, $I_D = 0.25\text{ mAdc}$) Temperature Coefficient (Positive)	(1) (3) $V_{(BR)DSS}$	30 —	— —	— —	Vdc mV/ $^\circ\text{C}$
Zero Gate Voltage Drain Current ($V_{DS} = 30\text{ Vdc}$, $V_{GS} = 0\text{ Vdc}$) ($V_{DS} = 15\text{ Vdc}$, $V_{GS} = 0\text{ Vdc}$, $T_J = 70^\circ\text{C}$)	I_{DSS}	— —	— —	1.0 5.0	μAdc
Gate-Body Leakage Current ($V_{GS} = \pm 20\text{ Vdc}$, $V_{DS} = 0$)	I_{GSS}	—	—	100	nAdc

ON CHARACTERISTICS(1)

Gate Threshold Voltage ($V_{DS} = V_{GS}$, $I_D = 0.25\text{ mAdc}$) Threshold Temperature Coefficient (Negative)	(1) (3) $V_{GS(th)}$	0.7 —	— —	1.4 —	Vdc mV/ $^\circ\text{C}$
Static Drain-to-Source On-Resistance ($V_{GS} = 10\text{ Vdc}$, $I_D = 9.1\text{ Adc}$) ($V_{GS} = 4.5\text{ Vdc}$, $I_D = 7.3\text{ Adc}$)	(1) (3) $R_{DS(on)}$	— —	— —	20 30	m Ω
On-State Drain Current ($V_{DS} \leq 5.0\text{ V}$, $V_{GS} = 10\text{ V}$) ($V_{DS} \leq 5.0\text{ V}$, $V_{GS} = 4.5\text{ V}$)	$I_{D(on)}$	40 10	— —	— —	A
Forward Transconductance ($V_{DS} = 15\text{ Vdc}$, $I_D = 8.0\text{ Adc}$)	(1) g_{FS}	—	—	—	Mhos

DYNAMIC CHARACTERISTICS

Input Capacitance	$(V_{DS} = 30\text{ Vdc}$, $V_{GS} = 0\text{ Vdc}$, $f = 1.0\text{ MHz}$)	C_{iss}	—	—	TBD	pF
Output Capacitance		C_{oss}	—	—	TBD	
Transfer Capacitance		C_{rss}	—	—	TBD	

SWITCHING CHARACTERISTICS(2)

Turn-On Delay Time	$(V_{DD} = 15\text{ Vdc}$, $I_D = 1.0\text{ Adc}$, $V_{GS} = 10\text{ Vdc}$, $R_G = 6.0\ \Omega$) (1)	$t_{d(on)}$	—	—	TBD	ns
Rise Time		t_r	—	—	TBD	
Turn-Off Delay Time		$t_{d(off)}$	—	—	TBD	
Fall Time		t_f	—	—	TBD	
Gate Charge See Figure 8	$(V_{DS} = 15\text{ Vdc}$, $I_D = 4.6\text{ Adc}$, $V_{GS} = 10\text{ Vdc}$) (1)	Q_T	—	—	TBD	nC
		Q_1	—	—	—	
		Q_2	—	—	—	
		Q_3	—	—	—	

SOURCE-DRAIN DIODE CHARACTERISTICS

Forward On-Voltage(1)	$(I_S = 2.1\text{ Adc}$, $V_{GS} = 0\text{ Vdc}$) (1) $(I_S = 2.1\text{ Adc}$, $V_{GS} = 0\text{ Vdc}$, $T_J = 125^\circ\text{C}$)	V_{SD}	— —	— —	1.2 —	Vdc
Reverse Recovery Time See Figure 15	$(I_S = 2.1\text{ Adc}$, $V_{GS} = 0\text{ Vdc}$, $dI_S/dt = 100\text{ A}/\mu\text{s}$) (1)	t_{rr}	—	—	TBD	ns
		t_a	—	—	—	
		t_b	—	—	—	
Reverse Recovery Stored Charge		Q_{RR}	—	—	—	μC

(1) Pulse Test: Pulse Width $\leq 300\ \mu\text{s}$, Duty Cycle $\leq 2\%$.

(2) Switching characteristics are independent of operating junction temperature.

(3) Reflects typical values.

$$C_{pk} = \left| \frac{\text{Max limit} - \text{Typ}}{3 \times \text{SIGMA}} \right|$$

(4) Repetitive rating; pulse width limited by maximum junction temperature.

PACKAGE DIMENSIONS

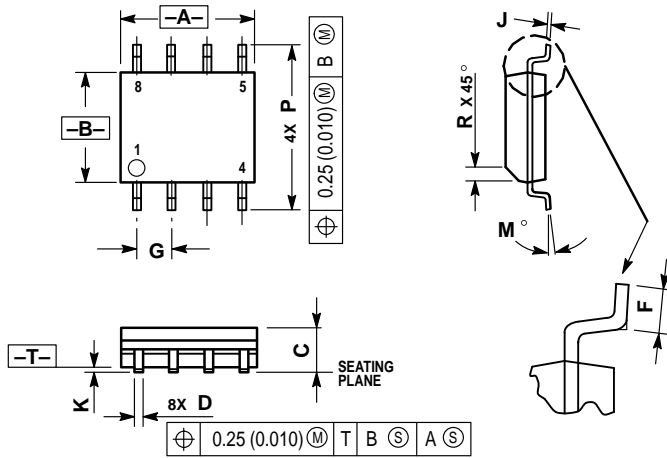

- NOTES:
1. DIMENSIONS A AND B ARE DATUMS AND T IS A DATUM SURFACE.
 2. DIMENSIONING AND TOLERANCING PER ANSI Y14.5M, 1982.
 3. DIMENSIONS ARE IN MILLIMETER.
 4. DIMENSION A AND B DO NOT INCLUDE MOLD PROTRUSION.
 5. MAXIMUM MOLD PROTRUSION 0.15 PER SIDE.
 6. DIMENSION D DOES NOT INCLUDE MOLD PROTRUSION. ALLOWABLE DAMBAR PROTRUSION SHALL BE 0.127 TOTAL IN EXCESS OF THE D DIMENSION AT MAXIMUM MATERIAL CONDITION.

DIM	MILLIMETERS	
	MIN	MAX
A	4.80	5.00
B	3.80	4.00
C	1.35	1.75
D	0.35	0.49
F	0.40	1.25
G	1.27 BSC	
J	0.18	0.25
K	0.10	0.25
M	0°	7°
P	5.80	6.20
R	0.25	0.50

- STYLE 13:
- PIN 1. SOURCE
 - SOURCE
 - SOURCE
 - GATE
 - DRAIN
 - DRAIN
 - DRAIN
 - DRAIN

CASE 751-05
SO-8
ISSUE P

Motorola reserves the right to make changes without further notice to any products herein. Motorola makes no warranty, representation or guarantee regarding the suitability of its products for any particular purpose, nor does Motorola assume any liability arising out of the application or use of any product or circuit, and specifically disclaims any and all liability, including without limitation consequential or incidental damages. "Typical" parameters which may be provided in Motorola data sheets and/or specifications can and do vary in different applications and actual performance may vary over time. All operating parameters, including "Typicals" must be validated for each customer application by customer's technical experts. Motorola does not convey any license under its patent rights nor the rights of others. Motorola products are not designed, intended, or authorized for use as components in systems intended for surgical implant into the body, or other applications intended to support or sustain life, or for any other application in which the failure of the Motorola product could create a situation where personal injury or death may occur. Should Buyer purchase or use Motorola products for any such unintended or unauthorized application, Buyer shall indemnify and hold Motorola and its officers, employees, subsidiaries, affiliates, and distributors harmless against all claims, costs, damages, and expenses, and reasonable attorney fees arising out of, directly or indirectly, any claim of personal injury or death associated with such unintended or unauthorized use, even if such claim alleges that Motorola was negligent regarding the design or manufacture of the part. Motorola and are registered trademarks of Motorola, Inc. Motorola, Inc. is an Equal Opportunity/Affirmative Action Employer.

Mfax is a trademark of Motorola, Inc.

How to reach us:

USA/EUROPE/Locations Not Listed: Motorola Literature Distribution; P.O. Box 5405, Denver, Colorado 80217. 303-675-2140 or 1-800-441-2447

JAPAN: Nippon Motorola Ltd.; Tatsumi-SPD-JLDC, 6F Seibu-Butsuryu-Center, 3-14-2 Tatsumi Koto-Ku, Tokyo 135, Japan. 81-3-3521-8315

Mfax™: RMFAX0@email.sps.mot.com – TOUCHTONE 602-244-6609 – US & Canada ONLY 1-800-774-1848

ASIA/PACIFIC: Motorola Semiconductors H.K. Ltd.; 8B Tai Ping Industrial Park, 51 Ting Kok Road, Tai Po, N.T., Hong Kong. 852-26629298

INTERNET: <http://www.mot.com/SPS/>

