

9-Bit Shift Register

The MC10E100E142 is a 9-bit shift register, designed with byte-parity applications in mind. The E142 performs serial/parallel in and serial/parallel out, shifting in one direction. The nine inputs D0 – D8 accept parallel input data, while S-IN accepts serial input data. The Qn outputs do not need to be terminated for the shift operation to function. To minimize noise and power, any Q output not used should be left unterminated.

- 700MHz Min. Shift Frequency
- 9-Bit for Byte-Parity Applications
- Asynchronous Master Reset
- Dual Clocks
- Extended 100E V_{EE} Range of – 4.2V to – 5.46V
- 75kΩ Input Pulldown Resistors

The SEL (Select) input pin is used to switch between the two modes of operation — SHIFT and LOAD. The shift direction is from bit 0 to bit 8. Input data is accepted by the registers a set-up time before the positive going edge of CLK1 or CLK2; shifting is also accomplished on the positive clock edge. A HIGH on the Master Reset pin (MR) asynchronously resets all the registers to zero.

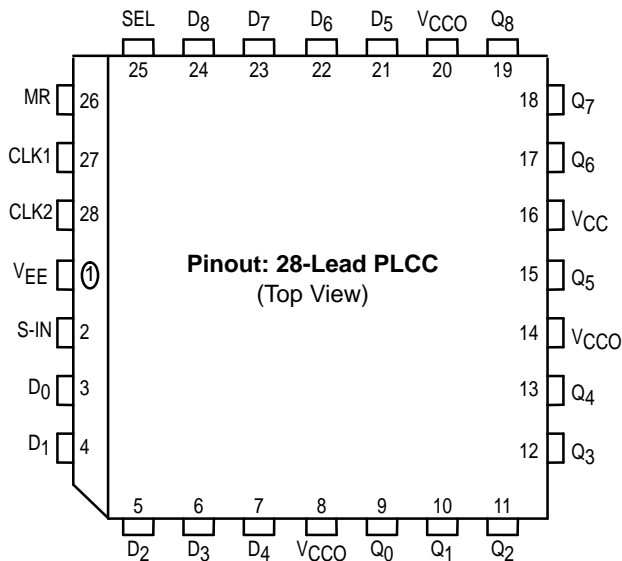

PIN NAMES

Pin	Function
D ₀ – D ₈	Parallel Data Inputs
S-IN	Serial Data Input
SEL	Mode Select Input
CLK1, CLK2	Clock Inputs
MR	Master Reset
Q ₀ – Q ₈	Data Outputs

FUNCTIONS

SEL	Mode
L	Load
H	Shift

MC10E142
MC100E142

**9-BIT SHIFT
REGISTER**

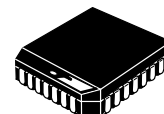

FN SUFFIX
PLASTIC PACKAGE
CASE 776-02

LOGIC DIAGRAM

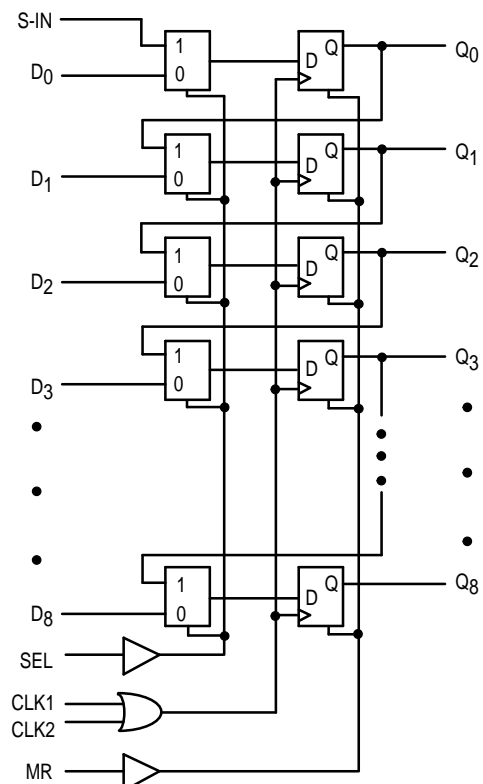

MC10E142 MC100E142

DC CHARACTERISTICS ($V_{EE} = V_{EE}(\text{min})$ to $V_{EE}(\text{max})$; $V_{CC} = V_{CCO} = \text{GND}$)

Symbol	Characteristic	0°C			25°C			85°C			Unit	Condition
		min	typ	max	min	typ	max	min	typ	max		
I_{IH}	Input HIGH Current			150			150			150	μA	
I_{EE}	Power Supply Current										mA	
	10E		120	145		120	145		120	145		
	100E		120	145		120	145		138	165		

AC CHARACTERISTICS ($V_{EE} = V_{EE}(\text{min})$ to $V_{EE}(\text{max})$; $V_{CC} = V_{CCO} = \text{GND}$)

Symbol	Characteristic	0°C			25°C			85°C			Unit	Condition
		min	typ	max	min	typ	max	min	typ	max		
f_{SHIFT}	Max. Shift Frequency	700	900		700	900		700	900		MHz	
t_{PLH} t_{PHL}	Propagation Delay to Output										ps	
	Clk MR	600 600	800 800	1000 1000	600 600	800 800	1000 1000	600 600	800 800	1000 1000		
t_s	Setup Time										ps	
	D SEL	50 300	-100 150		50 300	-100 150		50 300	-100 150			
t_h	Hold Time										ps	
	D SEL	300 75	100 -150		300 75	100 -150		300 75	100 -150			
t_{RR}	Reset Recovery Time	900	700		900	700		900	700		ps	
t_{PW}	Minimum Pulse Width Clk, MR	400			400			400			ps	
t_{SKEW}	Within-Device Skew		75			75			75		ps	Note 1
t_r t_f	Rise/Fall Times 20 - 80%	300	525	800	300	525	800	300	525	800	ps	

1. Within-device skew is defined as identical transitions on similar paths through a device.

OUTLINE DIMENSIONS

FN SUFFIX
 PLASTIC PLCC PACKAGE
 CASE 776-02
 ISSUE D



NOTES:

- DATUMS -L-, -M-, AND -N- DETERMINED WHERE TOP OF LEAD SHOULDER EXITS PLASTIC BODY AT MOLD PARTING LINE.
- DIM G1, TRUE POSITION TO BE MEASURED AT DATUM -T-, SEATING PLANE.
- DIM R AND U DO NOT INCLUDE MOLD FLASH. ALLOWABLE MOLD FLASH IS 0.010 (0.250) PER SIDE.
- DIMENSIONING AND TOLERANCING PER ANSI Y14.5M, 1982.
- CONTROLLING DIMENSION: INCH.
- THE PACKAGE TOP MAY BE SMALLER THAN THE PACKAGE BOTTOM BY UP TO 0.012 (0.300). DIMENSIONS R AND U ARE DETERMINED AT THE OUTERMOST EXTREMES OF THE PLASTIC BODY EXCLUSIVE OF MOLD FLASH, TIE BAR BURRS, GATE BURRS AND INTERLEAD FLASH, BUT INCLUDING ANY MISMATCH BETWEEN THE TOP AND BOTTOM OF THE PLASTIC BODY.
- DIMENSION H DOES NOT INCLUDE DAMBAR PROTRUSION OR INTRUSION. THE DAMBAR PROTRUSION(S) SHALL NOT CAUSE THE H DIMENSION TO BE GREATER THAN 0.037 (0.940). THE DAMBAR INTRUSION(S) SHALL NOT CAUSE THE H DIMENSION TO BE SMALLER THAN 0.025 (0.635).

DIM	INCHES		MILLIMETERS	
	MIN	MAX	MIN	MAX
A	0.485	0.495	12.32	12.57
B	0.485	0.495	12.32	12.57
C	0.165	0.180	4.20	4.57
E	0.090	0.110	2.29	2.79
F	0.013	0.019	0.33	0.48
G	0.050 BSC		1.27 BSC	
H	0.026	0.032	0.66	0.81
J	0.020	—	0.51	—
K	0.025	—	0.64	—
R	0.450	0.456	11.43	11.58
U	0.450	0.456	11.43	11.58
V	0.042	0.048	1.07	1.21
W	0.042	0.048	1.07	1.21
X	0.042	0.056	1.07	1.42
Y	—	0.020	—	0.50
Z	2°		10°	
G1	0.410	0.430	10.42	10.92
K1	0.040	—	1.02	—

Motorola reserves the right to make changes without further notice to any products herein. Motorola makes no warranty, representation or guarantee regarding the suitability of its products for any particular purpose, nor does Motorola assume any liability arising out of the application or use of any product or circuit, and specifically disclaims any and all liability, including without limitation consequential or incidental damages. "Typical" parameters which may be provided in Motorola data sheets and/or specifications can and do vary in different applications and actual performance may vary over time. All operating parameters, including "Typicals" must be validated for each customer application by customer's technical experts. Motorola does not convey any license under its patent rights nor the rights of others. Motorola products are not designed, intended, or authorized for use as components in systems intended for surgical implant into the body, or other applications intended to support or sustain life, or for any other application in which the failure of the Motorola product could create a situation where personal injury or death may occur. Should Buyer purchase or use Motorola products for any such unintended or unauthorized application, Buyer shall indemnify and hold Motorola and its officers, employees, subsidiaries, affiliates, and distributors harmless against all claims, costs, damages, and expenses, and reasonable attorney fees arising out of, directly or indirectly, any claim of personal injury or death associated with such unintended or unauthorized use, even if such claim alleges that Motorola was negligent regarding the design or manufacture of the part. Motorola and  are registered trademarks of Motorola, Inc. Motorola, Inc. is an Equal Opportunity/Affirmative Action Employer.

How to reach us:

USA/EUROPE/Locations Not Listed: Motorola Literature Distribution;
P.O. Box 20912; Phoenix, Arizona 85036. 1-800-441-2447 or 602-303-5454

MFAX: RMFAX0@email.sps.mot.com – TOUCHTONE 602-244-6609
INTERNET: <http://Design-NET.com>

JAPAN: Nippon Motorola Ltd.; Tatsumi-SPD-JLDC, 6F Seibu-Butsuryu-Center,
3-14-2 Tatsumi Koto-Ku, Tokyo 135, Japan. 03-81-3521-8315

ASIA/PACIFIC: Motorola Semiconductors H.K. Ltd.; 8B Tai Ping Industrial Park,
51 Ting Kok Road, Tai Po, N.T., Hong Kong. 852-26629298

