

# MC145076

## Product Preview

# MC145076 Stereo Audio FIR Smoothing Filter CMOS

The MC145076 is a combination re-clocking and smoothing filter designed especially for the MC145074 Stereo Audio DAC. Its versatility however, allows it to be used with any single bit-stream data converter to provide output reconstruction filtering, and to improve performance by restoring pulse shape integrity. The MC145076 provides a well controlled, filtered output that can be used directly, or with a current summing operational amplifier.

The MC145076 is intended to be one half of a two-chip solution for serial bit stream DACs. The analog filtering function of the MC145076 eases the digital filtering requirements at the input to the digital noise shaping modulator, and eliminates the need for precision analog output filtering capacitors, resulting in lower overall system cost. The MC145076 pulse shape restoration frees the designer from analog pitfalls that can impact performance, thereby lowering the risk of new product development with a sigma-delta DAC.

- Single-Ended Stereo Outputs Require no Additional Smoothing Filters
- 86 dB S/D, 96 dB S/N with MC145074 @ 192 x OSR Single Ended
- > 100 dB S/(N+D) @ 256 OSR, Differential Mode
- 18.5 MHz Maximum Serial Data Input Rate
- - 80 dB Cross Channel Interference
- 72-Tap FIR with > 40 dB Alias Filtering
- Operating Temperature Range: - 40 to + 85°C
- Buffered Data Clock Output for Ease of Data Generation
- 16-Pin Narrow Body SOIC Package
- Single Supply Operation: + 5 V

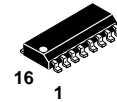

**D SUFFIX**  
16-PIN SOG  
CASE 751B-05

### ORDERING INFORMATION

MC145076D SOG Package

### PIN ASSIGNMENT

V <sub>D</sub> DA	1	16	X <sub>out</sub>
X <sub>in</sub>	2	15	GND
BIAS	3	14	IOL
DIV2	4	13	GND
DIL	5	12	GND
DIR	6	11	IOR
TEST	7	10	GND
V <sub>D</sub> DD	8	9	CLKOUT

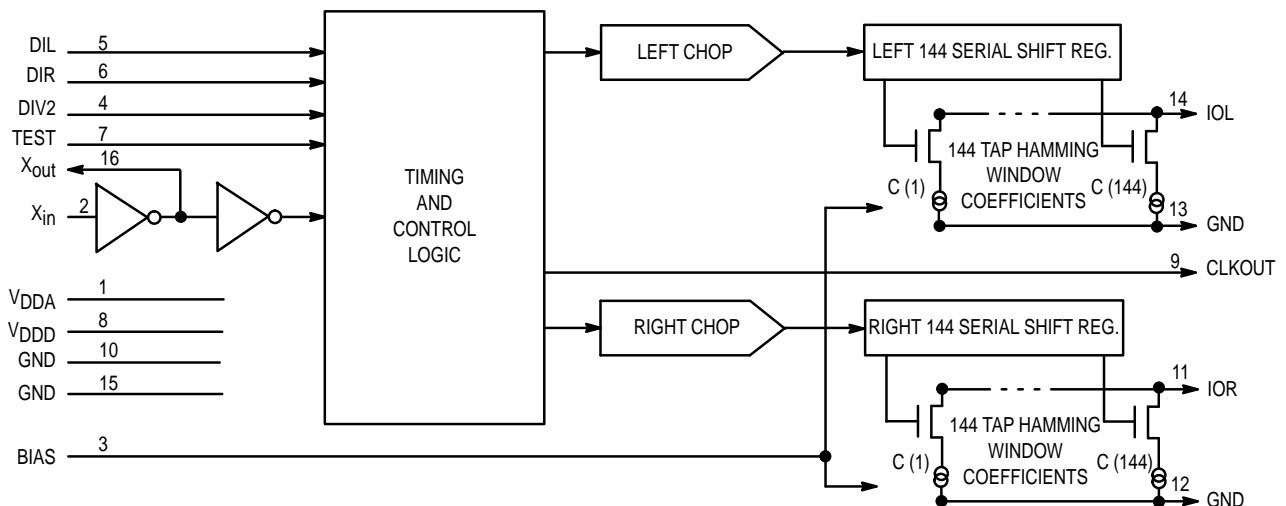

This document contains information on a product under development. Motorola reserves the right to change or discontinue this product without notice.

## MAXIMUM RATINGS\*

Symbol	Parameter	Value	Unit
V <sub>DD</sub>	DC Supply Voltage (Referenced to GND)	6.0	V
V <sub>in</sub>	DC Input Voltage	GND – 0.5 to V <sub>DD</sub> + 0.5	V
V <sub>out</sub>	DC Output Voltage	GND – 0.5 to V <sub>DD</sub> + 0.5	V
I <sub>in</sub>	DC Input Current, per Pin	± 10	mA
I <sub>out</sub>	DC Output Current, per Pin	± 20	mA
I <sub>DD</sub> , I <sub>GND</sub>	DC Supply Current, V <sub>DD</sub> and GND Pins	± 60	mA
T <sub>stg</sub>	Storage Temperature	– 55 to 150	°C
T <sub>L</sub>	Lead Temperature, 1 mm from Case for 10 Seconds	260	°C

\* Maximum Ratings are those values beyond which damage to the device may occur. Functional operation should be restricted to the Operation Ranges below.

This device contains protection circuitry to guard against damage due to high static voltages or electric fields. However, precautions must be taken to avoid applications of any voltage higher than maximum rated voltages to this high-impedance circuit. For proper operation, V<sub>in</sub> and V<sub>out</sub> should be constrained to the range GND ≤ (V<sub>in</sub> or V<sub>out</sub>) ≤ V<sub>DD</sub>.

Unused inputs must always be tied to an appropriate logic voltage level (e.g., either GND or V<sub>DD</sub>). Unused outputs must be left open.

## OPERATION RANGES (Applicable to Guaranteed Limits)

Symbol	Parameter	Value	Unit
V <sub>DD</sub>	DC Supply Voltage	4.5 to 5.5	V
V <sub>IOL</sub> , V <sub>IOR</sub>	IOL, IOR Virtual Ground	V <sub>DD</sub> – 2.0 to V <sub>DD</sub>	V
T <sub>A</sub>	Ambient Operating Temperature	– 40 to + 85	°C

## DC ELECTRICAL CHARACTERISTICS

(Voltages Referenced to GND, Full Temperature and Voltage Ranges per Operation Ranges Table, unless otherwise indicated)

Symbol	Parameter	Guaranteed Limit	Unit
V <sub>IH</sub>	Minimum High-Level Input Voltage	0.7 × V <sub>DD</sub>	V
V <sub>IL</sub>	Maximum Low-Level Input Voltage	0.3 × V <sub>DD</sub>	V
V <sub>OH</sub>	Minimum High-Level Output Voltage	I <sub>OH</sub> = 0.4 mA V <sub>DD</sub> – 0.3	V
V <sub>OL</sub>	Maximum Low-Level Output Voltage	I <sub>OL</sub> = 0.4 mA GND + 0.3	V
I <sub>DD</sub>	Maximum Power Supply Current	R <sub>bias</sub> = 4640 Ω 40	mA
I <sub>OL</sub> , I <sub>OR</sub>	Left/Right Channel Output Current*	2 ± 20%	mA
I <sub>lkg</sub>	Input Leakage Current	± 10	μA

\* 50% Duty Cycle, V<sub>DDA</sub> = 5 V, R<sub>bias</sub> = 4640 Ω

## SINGLE ENDED ANALOG CHARACTERISTICS

(X<sub>in</sub> = 16.9344 MHz, DIV2 = 0, f<sub>in</sub> = 990.527 Hz, 20 Bit 2nd Order Modulator Input Data)

Parameter	Test Conditions	Min	Typ	Max	Unit
Dynamic Range	S/(N+D) @ – 60 dB input, + 60 dB	—	96	—	dB
S/(N+D)	Flat A-weighted (– 6 dB) 25 to 75% peak to peak input duty cycle (– 20 dB)	86 —	90 80*	—	dB
Idle Channel Noise	CLKOUT/4 digital input data pattern	—	105	—	dB
60 Hz Power Supply Rejection	With 47 μF and 4640 Ω on Bias Pin	—	40	—	dB

\* Noise performance limited by second order digital modulator.

**AC ELECTRICAL CHARACTERISTICS** (Full Temperature and Voltage Ranges per Operation Ranges Table)

Symbol	Parameter	Guaranteed Limit	Unit
f	Clock Frequency, $X_{in}$	37	MHz
$t_{PLH}$ , $t_{PHL}$	Maximum Propagation Delay, $X_{in}$ to $X_{out}$	5	ns
$t_{TLH}$ , $t_{THL}$	Maximum Rise/Fall Time, $X_{out}$	10	ns
$t_{PLH}$ , $t_{PHL}$	Maximum Propagation Delay, $X_{in}$ to CLKOUT	30	ns
$t_{TLH}$ , $t_{THL}$	Maximum Rise/Fall Time, CLKOUT	10	ns
$t_{su}$	Minimum DIR, DIL Setup Time From $X_{in}$	5	ns
$t_h$	Maximum DIR, DIL Hold Time From $X_{in}$	20	ns

NOTE: 10 pF load capacitance,  $X_{in}$  rise and fall times set at 2 ns.

**TIMING WAVEFORMS**

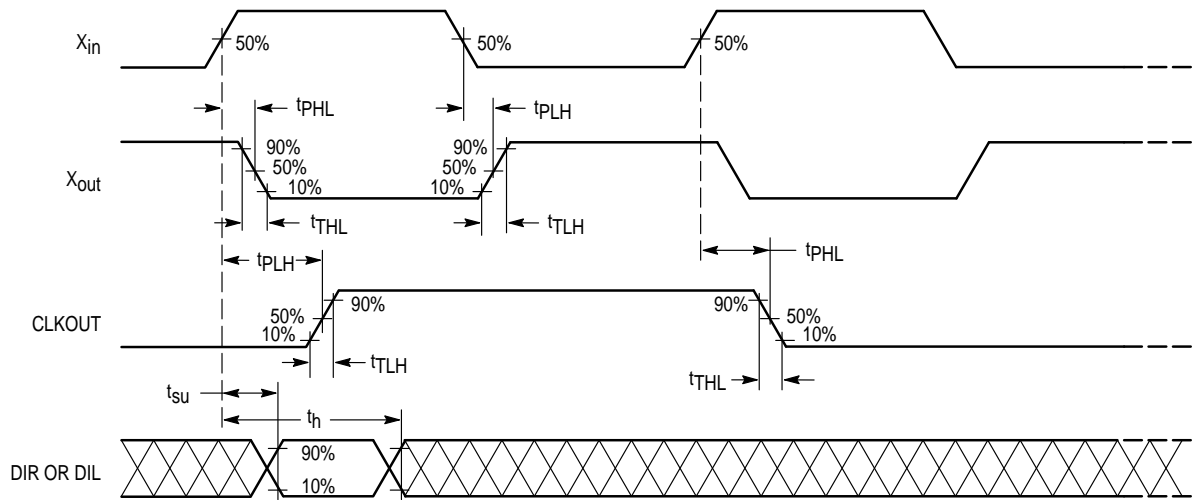

Figure 1.

## PIN DESCRIPTIONS

### **X<sub>in</sub>, X<sub>out</sub>**

#### **Oscillator Inverter Input and Output (Pins 2, 16)**

If an external clock is used to drive the MC145076, the clock should be connected to X<sub>in</sub> pin. For maximum performance however, it is recommended that these pins be used in conjunction as a crystal oscillator.

### **BIAS**

#### **Bias Adjust (Pin 3)**

For normal device operation, this pin should be connected to ground through a 4.7 kΩ resistor, which provides nominal quiescent output current of 2 mA each channel. In addition to the 4.7 kΩ resistor, a 47 μF capacitor may be connected from this pin to the V<sub>DD</sub> supply.

### **DIV2**

#### **Active-High Clock Divider Control Input (Pin 4)**

When this pin is at a logic low level, the internal clock will be equal to the oscillator, (X<sub>in</sub>) frequency, and data can be clocked into the device at an fX<sub>in</sub>/2 rate. When this pin is at a logic high level, the internal clock is one-half the X<sub>in</sub> oscillator frequency, and data can be clocked into the device at an fX<sub>in</sub>/4 rate.

### **DIL, DIR**

#### **Left/Right Channel Data Inputs (Pins 5,6)**

These pins are the left and right digital input data pins from the single bit-stream sigma-delta DAC. Serial input data to the MC145076 is clocked in near the rising edge of CLKOUT.

### **TEST**

#### **Active-High Factory Test Mode Input (Pin 7)**

This pin is reserved for factory testing, and should be connected to device ground for normal device operation.

### **CLKOUT**

#### **Buffered Divided Clock Output (Pin 9)**

This pin provides a buffered clock output to be used as the clock source for a sigma-delta bit stream generator. The CLKOUT frequency is one-half the X<sub>in</sub> frequency if DIV2 = 0, and one-fourth the X<sub>in</sub> frequency if DIV2 = 1. The serial input data is clocked in near the rising edge of CLKOUT.

### **IOR, IOL**

#### **Left/Right Channel Current Outputs (Pins 11,14)**

These pins are the current sink outputs of the smoothed single-bit input data.

### **V<sub>DDD</sub>, V<sub>DDA</sub>**

#### **Device Supply Pins (Pins 1,8)**

These two pins are the positive power supply pins for the MC145076, nominally 5 V. For proper device operation, it is recommended that 0.1 μF and 10 μF capacitors be connected from these pins to ground via the shortest possible path.

### **GND**

#### **Device Ground Pins (Pins 10,12,13,15)**

These pins are the ground pins for the device.

## FUNCTIONAL DESCRIPTION

Serial bitstream Digital-to-Analog Converters (DACs) have become commonplace due to their ability to use over-sampling techniques to shape quantization noise. This noise shaping ability enables devices to be built that do not require the component matching of conventional architectures.

The MC145076 bitstream FIR smoothing filter consists of two shift registers, two sets of Hamming Window weighted current source summing networks, and a crystal oscillator inverting buffer.

The current source summing networks are used to implement a Hamming Window function within the MC145076. Each current source tap sinks a constant current that does not change with the number of bits that are set in the shift register. Therefore, each tap acts as a separate single-bit converter with excellent linearity characteristics. The Hamming window was chosen for the FIR filter coefficients because this allows a slightly better second lobe attenuation close to the band where the sampling images are the most troublesome. For a 256 OSR, the MC145076 FIR filter provides greater than 40 dB of stop band attenuation, with approximately 50 dB of attenuation at the 8x image frequencies. This results in an output with full scale images of less than -70 dB and out-of-band noise better than -60 dB. For other OSR rates, the filter response scales linearly.

## CRYSTAL OSCILLATOR

Provisions for an on-chip crystal oscillator are provided to insure that the clock will be as clean as possible internal to the MC145076 where the digital-to-analog conversion occurs, thus assuring maximum performance. An output clock buffer is provided for driving additional off-chip digital circuitry such as a digital noise shaper, over-sampling FIR filter, or DSP. The off-chip digital processing ensures that the digital switching noise on chip is kept to a minimum.

## APPLICATIONS

A smoothing filter is required when using a sigma-delta DAC to reduce the out-of-band noise, and to prevent the high frequencies from intermodulating to lower frequencies. Using the MC145076 with its current sink output is easier than a voltage output filter because it gives a degree of immunity to mutual ground paths between it and the next amplifier.

The circuit shown in Figure 2 is excellent for most applications. However, differential operation does reduce low level switching noise that appears as second harmonic distortion and weak background noise. Although a simple resistor on each current source output to V<sub>DDA</sub> may be adequate for some applications, the OpAmps provide power supply noise rejection, and, in Figures 2 and 4, also reduce the signal swing on the current output pin of the part to further improve distortion.

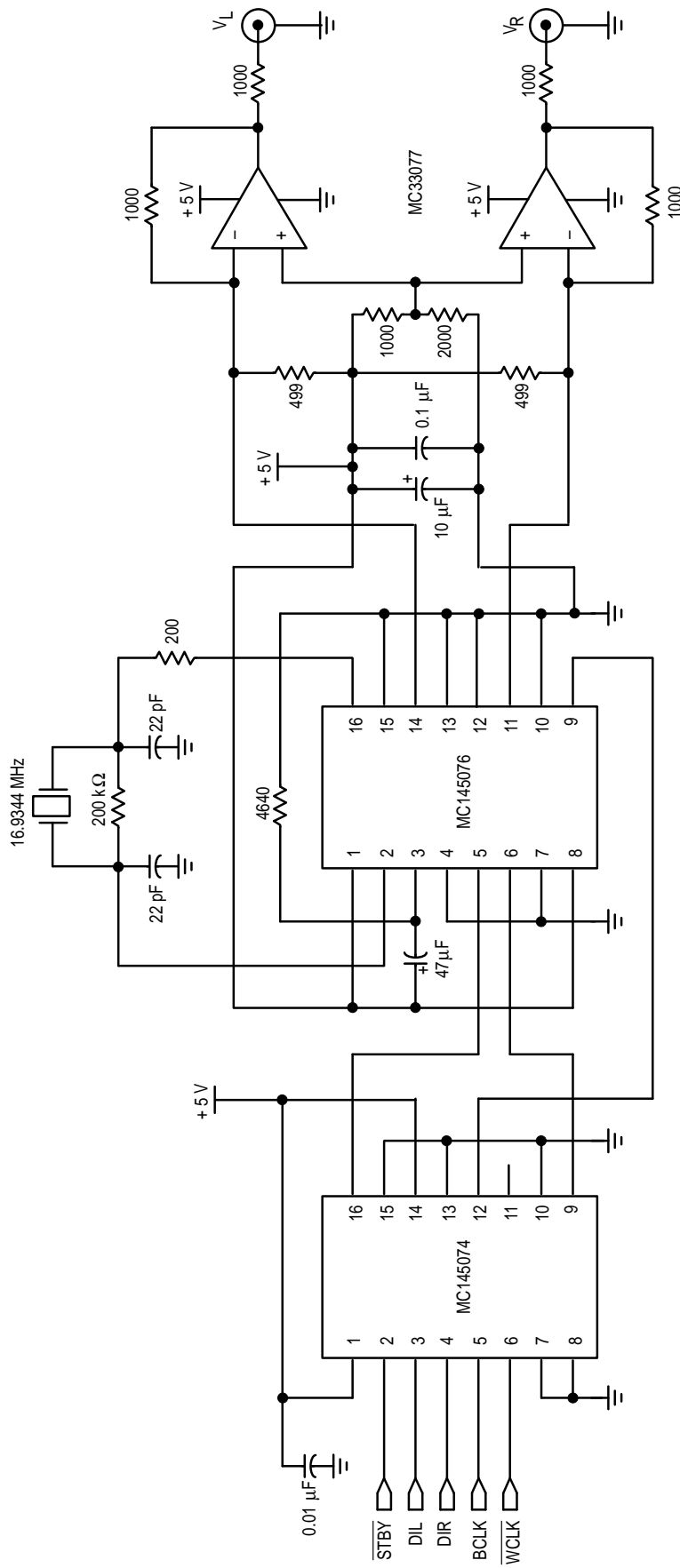

Figure 2. Low Cost +5 V Stereo Audio System, Typically 88 dB S/(N+D)

\* ALL RESISTORS 1%

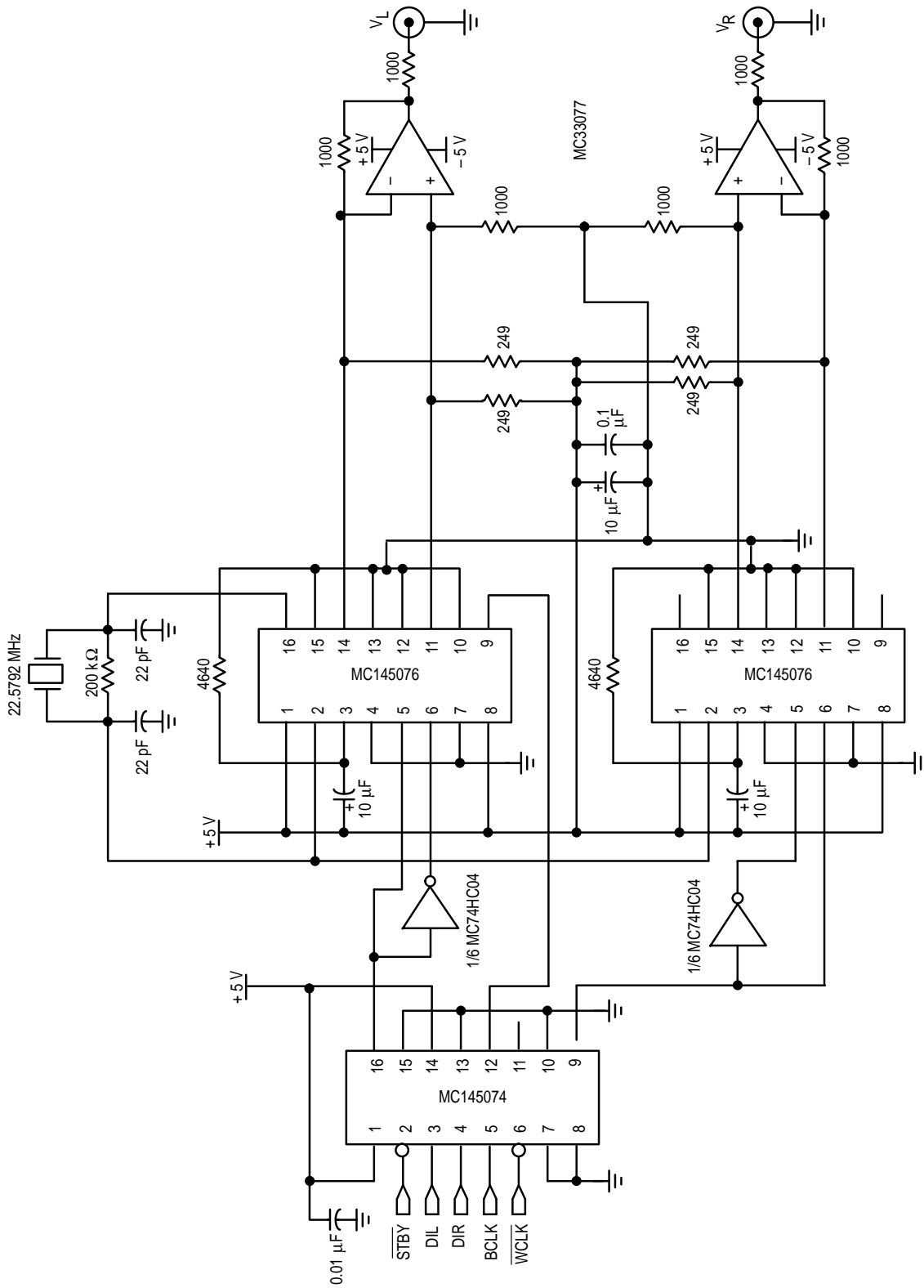

Figure 3. Mid Performance Stereo Audio System, Typically 98 dB S/(N+D)

\* ALL RESISTORS 1%

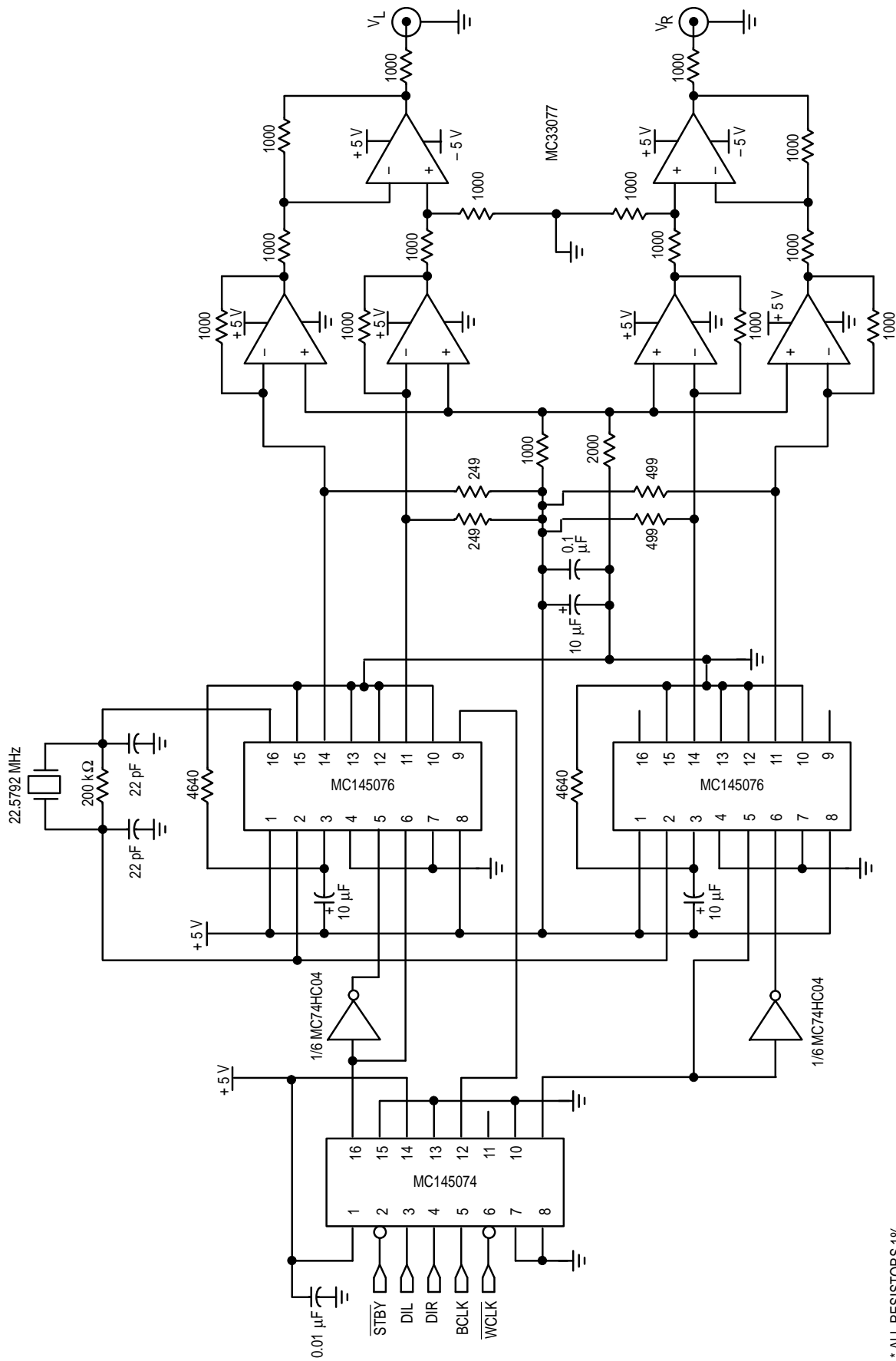
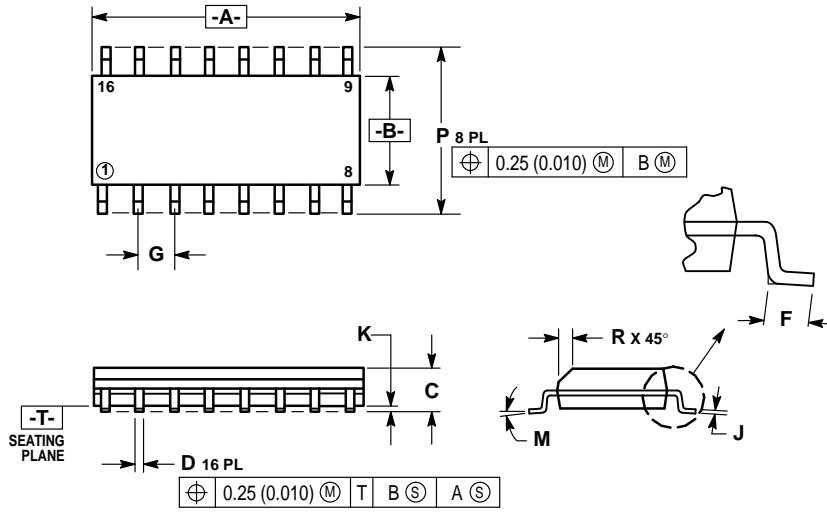

Figure 4. High Performance Stereo Audio System, Typically 105 dB S/(N+D)

\* ALL RESISTORS 1%

# PACKAGE DIMENSIONS

## SOIC PACKAGE CASE 751B-05



**NOTES:**

1. DIMENSIONING AND TOLERANCING PER ANSI Y14.5M, 1982.
2. CONTROLLING DIMENSION: MILLIMETER.
3. DIMENSIONS A AND B DO NOT INCLUDE MOLD PROTRUSION.
4. MAXIMUM MOLD PROTRUSION 0.15 (0.006) PER SIDE.
5. DIMENSION D DOES NOT INCLUDE DAMBAR PROTRUSION. ALLOWABLE DAMBAR PROTRUSION SHALL BE 0.127 (0.005) TOTAL IN EXCESS OF THE D DIMENSION AT MAXIMUM MATERIAL CONDITION.

DIM	MILLIMETERS		INCHES	
	MIN	MAX	MIN	MAX
A	9.80	10.00	0.386	0.393
B	3.80	4.00	0.150	0.157
C	1.35	1.75	0.054	0.068
D	0.35	0.49	0.014	0.019
F	0.40	1.25	0.016	0.049
G	1.27 BSC		0.050 BSC	
J	0.19	0.25	0.008	0.009
K	0.10	0.25	0.004	0.009
M	0°	7°	0°	7°
P	5.80	6.20	0.229	0.244
R	0.25	0.50	0.010	0.019

Motorola reserves the right to make changes without further notice to any products herein. Motorola makes no warranty, representation or guarantee regarding the suitability of its products for any particular purpose, nor does Motorola assume any liability arising out of the application or use of any product or circuit, and specifically disclaims any and all liability, including without limitation consequential or incidental damages. "Typical" parameters which may be provided in Motorola data sheets and/or specifications can and do vary in different applications and actual performance may vary over time. All operating parameters, including "Typicals" must be validated for each customer application by customer's technical experts. Motorola does not convey any license under its patent rights nor the rights of others. Motorola products are not designed, intended, or authorized for use as components in systems intended for surgical implant into the body, or other applications intended to support or sustain life, or for any other application in which the failure of the Motorola product could create a situation where personal injury or death may occur. Should Buyer purchase or use Motorola products for any such unintended or unauthorized application, Buyer shall indemnify and hold Motorola and its officers, employees, subsidiaries, affiliates, and distributors harmless against all claims, costs, damages, and expenses, and reasonable attorney fees arising out of, directly or indirectly, any claim of personal injury or death associated with such unintended or unauthorized use, even if such claim alleges that Motorola was negligent regarding the design or manufacture of the part. Motorola and are registered trademarks of Motorola, Inc. Motorola, Inc. is an Equal Opportunity/Affirmative Action Employer.

**How to reach us:**

**USA/EUROPE/Locations Not Listed:** Motorola Literature Distribution;  
P.O. Box 20912; Phoenix, Arizona 85036. 1-800-441-2447 or 602-303-5454

**JAPAN:** Nippon Motorola Ltd.; Tatsumi-SPD-JLDC, 6F Seibu-Butsuryu-Center,  
3-14-2 Tatsumi Koto-Ku, Tokyo 135, Japan. 03-81-3521-8315

**MFAX:** RMFAX0@email.sps.mot.com - TOUCHTONE 602-244-6609  
**INTERNET:** http://Design-NET.com

**ASIA/PACIFIC:** Motorola Semiconductors H.K. Ltd.; 8B Tai Ping Industrial Park,  
51 Ting Kok Road, Tai Po, N.T., Hong Kong. 852-26629298



MC145076/D

