

MC145220 Evaluation Board Manual

INTRODUCTION

The MC145220EVK makes it easy to exercise features of the MC145220 and build PLLs which meet individual performance requirements. The EVK is controlled through menu driven software operating on an IBM PC or compatible. Other Motorola PLL EVKs (MC145190, MC145191, MC145192, MC145200, MC145201, MC145202) in up to three-board cascades can use the same program. Frequency defaults that apply to each are automatically selected. All board functions are controlled through the printer port of an IBM PC. Up to three different EVKs may be controlled at the same time from one printer port. The functional block diagram is given in Figure 1.

This manual is divided into three sections. Section 1 describes the hardware, Section 2 describes the software, and Section 3 is the command summary.

All brand names and product names appearing in this document are registered trademarks or trademarks of their respective holders.

This document contains information on a new product. Specifications and information herein are subject to change without notice.

REV 2
10/96

© Motorola, Inc. 1996



MOTOROLA

MC145220EVK TABLE OF CONTENTS

Section 1 – Hardware	5
Features	5
Contents of Evaluation Kit	5
Getting Started	5
Modifications	5
Typical Performance	7
Support Material	8
Production Test	8
Board Operation	8
Dual Mode Output	9
External Reference Input	11
Data Transfer from Computer to EVK	11
Printer Port Configuration	13
Section 2 – Software Descriptions	14
Introduction	14
Purpose	14
Description	14
User Interface	14
Install	14
Uninstall	15
Conventions	15
Alert and Error Messages	15
Screens	18
'Define boards to program'	18
Help Screen	19
'Select from the available options'	20
'Available Boards'	20
'MC145xxx Commands'	20
'Initialization/System Setup Commands'	20
PLL Output Frequency	22
REF _{in} Frequency and Channel Spacing	23
Set Default Low Frequency	24
Set Function of Output A	25
Change C Register and Prescale	26
Change C Register, PD _{out} Current	27
Change C Register, Phase Detector Select	28
Change C Register, Polarity	29
Change C Register, Standby	30
Set Output Port Address	31
Set Crystal or Reference Mode	32
Section 3 – Command Summary	33
[A]! Set board A as target	33
[B]! Set board B as target	33
[C]! Set board C as target	33
[L]! Set to low freq.	33
[M]! Set to medium freq.	34
[H]! Set to high freq.	34
[W] Change default low frequency	34
[Y] Change default medium frequency	35
[Z] Change default high frequency	36
[U]! Step frequency up by step size	36
[D]! Step frequency down by step size	36
[O] Set PLL output frequency	37
[F] Set REF _{in} frequency and channel spacing	38

MC145220EVK TABLE OF CONTENTS, continued

[E] Set function of output A	39
[0]! Port	39
[1]! Data Out	39
[2]! fv	39
[3]! fr	39
[N] Change C Register and Prescale	40
[0] Change output A – (Port)	40
[0]! Reset output A to 0	40
[1]! Set output A to 1	40
[1] Change output B (Out B) (not available on '220)	40
[0]! Reset output B to 0	40
[1]! Set output B to 1	40
[2] Change PD _{out} current with Output A defined as port (not available on '220)	41
[0]! 70%	41
[1]! 80%	41
[2]! 90%	41
[3]! 100%	41
[2] Change PD _{out} current with Output A NOT defined as port (not available on '220)	41
[0]! 25%	41
[1]! 50%	41
[2]! 75%	41
[3]! 100%	41
[2] Change PD _{out} current (only available on '220)	42
[0]! 5%	42
[1]! 50%	42
[2]! 80%	42
[3]! 100%	42
[3] Change phase detector select	42
[0]! phi R & phi V	42
[1]! PD _{out}	42
[3] Change phase detector (only available on '220)	43
[0]! phi R & phi V	43
[1]! PD _{out}	43
[4] Change lock detect enable (not available on '220)	43
[0]! Output low	43
[1]! Enable output	43
[5] Change phase detector polarity	43
[0]! Non-invert PD _{out}	43
[1]! Invert PD _{out}	43
[6] Change standby	44
[0]! Normal operation	44
[1]! Standby	44
[7] Change prescale (only available on '220)	44
[0]! Prescale 32/33	44
[1]! Prescale 64/65	44
[R] Set crystal/reference mode	45
[0]! Crystal mode, shutdown	45
[1]! Crystal mode, active	45
[2]! Reference mode, REF _{in} enabled, REF _{out} low	45
[3]! Reference mode, REF _{out} = REF _{in}	45
[4]! Reference mode, REF _{out} = REF _{in} /2	45
[5]! Reference mode, REF _{out} = REF _{in} /4	45
[6]! Reference mode, REF _{out} = REF _{in} /8	45
[7]! Reference mode, REF _{out} = REF _{in} /16	45
[T]! Set target PLL on board	46
[P] Set output port address	46

MC145220EVK TABLE OF CONTENTS, continued

[G] Change board definitions	46
[I]! Initialize board(s), write all registers	46
[X]! Terminate demonstration program	46
[?]! View help screen	46
Appendix	47
MC145220 PLL Evaluation Board	47
MC145220 Power Supply and Reference	48
MC145220EVK Bus Interface	49
MC145220EVK Signal Plot — Dual Loop Mode Output at 70 MHz	50
MC145220EVK Signal Plot — Single Loop Mode PLL on 805 MHz	50
MC145220EVK Signal Plot — Single Loop Mode PLL on 738 MHz	51
Bill of Materials: MC145220 PLL Evaluation Board Rev. 4	52

SECTION 1 – HARDWARE

FEATURES

1. The EVK is a complete working synthesizer, including VCOs.
2. Board is controlled by an IBM PC-compatible computer through the printer port.
3. Up to three boards can be operated independently through one printer port.
4. A prototype area and mounting holes are provided for VCOs, mixers, and amplifiers.
5. External reference input can be used.
6. Five element loop filter is included.
7. Frequency range of operation, step size and reference frequency can be changed in the control program.
8. Lock Detect, Out A, and Out B on any single board are accessible through the printer port.

CONTENTS OF EVALUATION KIT

1. Assembled evaluation board.
2. Nine-foot flat cable with four DB-25 male connectors.
3. MC145220EVK manual.
4. 3.5" PC-compatible disk containing compiled program.
5. PLL device data sheets.

GETTING STARTED

To perform basic functions, do the following:

1. Plug in 12 volts at J8, observing the polarity marked on the board.
2. Short circuit section 1 of the DIP switch (S1) and open circuit all other sections.
3. Connect the supplied flat cable between the computer printer port and the DB-25 connector on the board (J9).
4. Type PLL at the DOS prompt. Then press enter.
5. Type the number that corresponds with the type of board given in the on-screen menu. The MC145220 may operate in single loop or dual loop mode. Then press Q.

You should now see the main menu displayed. There should be a signal present at J5 if single loop, or J12 if dual loop. The frequency will be the current output frequency given in the main menu. If the signal is not on the correct frequency, check to see if your printer port address is \$278 (hexadecimal 278). If not, then select the P menu item and enter the correct address. After returning to the main menu, select the I menu item to send data to the board. You should now be on frequency.

MODIFICATIONS

The user may modify the hardware, such as utilizing a different VCO, by using the prototyping area of the board. After such modifications are made, the default values in the software may need to be changed. This is facilitated from the 'Select from the available options' screen.

Note that the on-board voltage regulators allow for a maximum VCO control voltage range of 0.5 – 4.5 volts.

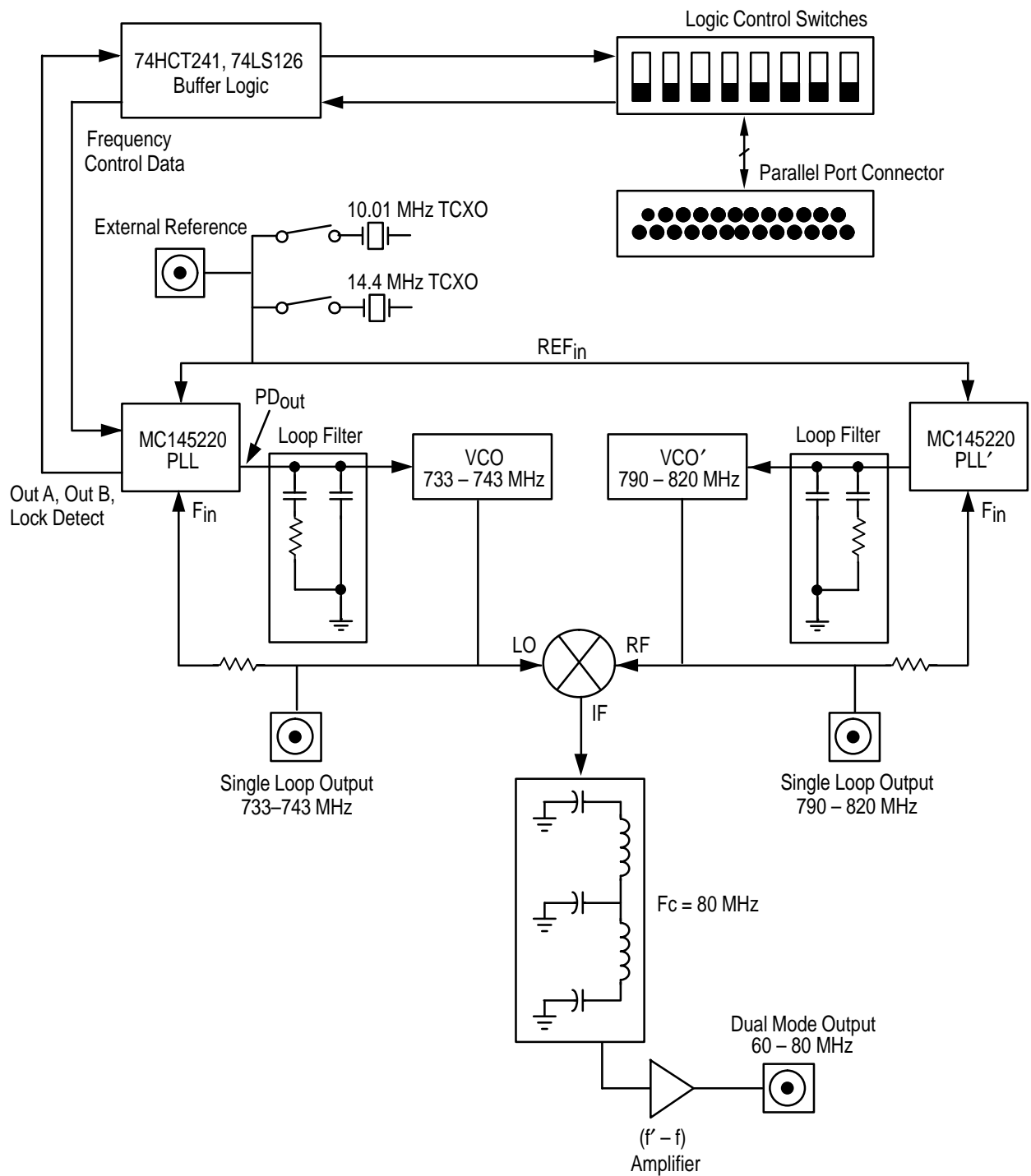

Figure 1. Evaluation Kit Block Diagram

TYPICAL PERFORMANCE

Typical performance applies only to the configuration as shipped. The MC145220EVK is shipped with $V+ = 5\text{ V}$. For lowest phase noise in single or dual loop mode, a $50\ \Omega$ load must be connected to J12.

	Single Loop PLL	Single Loop PLL'	Dual Loop PLL
Supply Voltage (J8)	11.5 – 12.5 V		
Supply Current (J8) (Note 1)	177 mA		
Available Current (Note 2)	45 mA		
Frequency Range (Note 3)	733 – 743 MHz	790 – 820 MHz	60 – 80 MHz
Reference Frequency (M1)	10.01 MHz		
Temperature Stability (M1, – 30°C to + 70°C)	< ± 2.5 ppm		
Reference Frequency (M5)	14.4 MHz		N/A
Temperature Stability (M5, – 30°C to + 85°C)	< ± 2 ppm		N/A
TCXO Aging (M1, M5)	< ± 1 ppm / year		
Step Size	10 kHz		10 Hz
Power Output	– 3.0 dBm	– 5.0 dBm	4.5 – 7.5 dBm
Frequency Accuracy	± 1.5 kHz	± 1.5 kHz	± 50 Hz
Reference Sidebands (Note 4)	– 57 dB	– 74 dB	– 57 dB
Phase Noise (100 Hz)	– 65 dBc/Hz	– 56 dBc/Hz	– 50 dBc/Hz
Phase Noise (10 kHz) (Note 5)	– 104 dBc/Hz	– 90 dBc/Hz	– 89 dBc/Hz
Switching Time (Note 6)	24 ms	40 ms	45 ms

NOTES:

- Supply current is current the board requires without user modifications.
- Available current is the sum of currents available to the user (in the prototype area) from the 5 V and 8.5 V supply. The 12 V supply is not regulated. Current at 12 V is limited by the external power supply. If the on-board VCO and amplifier are disconnected from the power bus, more current can be drawn in the prototype area. The current flowing into U5 (the 8.5 V regulator) should not exceed 180 mA. This will limit temperature rise in U5.
- Frequency ranges require use of the 5 V default charge pump supply voltage.
- VCO sidebands on PLL at low step sizes (10 kHz) are limited by control line leakage of the VCO. Up to 24 nA of leakage has been seen. At higher step sizes (100 kHz and above), this effect is much less noticeable. This did not affect PLL' because its VCO leakage was less than 10 pA.
- 10 kHz phase noise is limited by the PLL device noise. For low noise designs, the loop bandwidth is made narrower and the VCO is relied upon to provide the 10 kHz phase noise. This can be seen on the EVKs since the VCOs have much lower noise.
- 10 MHz step, within ± 1 kHz of final frequency ('220).
Due to the software architecture, when the user is measuring the switching time of a single board in dual loop mode, it takes 20 ms to load the data as compared to single loop mode, which takes 8 ms to load the data. This is a limitation of the software, not the IC.
To find the actual PLL switching time, subtract 8 or 20 ms from the switching time stated in the table.

SUPPORT MATERIAL

The following documents are included in the appendix:

1. Schematic diagram of MC145220EVK.
2. Bill of materials.
3. Parts layout diagram.
4. Mechanical drawing of board.
5. MC145220 data sheet.
6. Typical signal plots.

PRODUCTION TEST

After assembly is complete, the following alignment and test is performed:

1. The control program is started in '220 single loop mode.
2. [L]! is selected to set PLL frequency to 733 MHz.
3. Power is applied to the board. DIP switch section 1 is closed circuit with all others being open circuit.
4. After attaching computer cable, [I]! is selected.
5. Trim resistor VR1 is adjusted to obtain an output frequency at J5 of 733 MHz \pm 500 Hz.
6. Voltage at the control voltage test point (TP2) is measured. It must be > 0.5 V.
7. [H]! is selected.
8. Voltage at the control voltage test point (TP2) is measured. It must be < 4.4 V.
9. [T]! is selected to toggle to PLL'.
10. [L]! is selected to set PLL' frequency to 790 MHz.
11. Voltage at the control voltage test point (TP9) is measured. It must be > 0.5 V.
12. [H]! is selected to set PLL' frequency to 820 MHz.
13. Voltage at the control voltage test point (TP9) is measured. It must be < 4.4 V.
14. [G] is selected and the board type is changed to '220 dual loop mode.
15. [Q]!, then [I]!, is selected to initialize the dual mode output (J12) to 70 MHz. The frequency should be 70 MHz \pm 50 Hz.

If in step 5 it isn't possible to obtain a signal on frequency, the adjustment screw in M1 may be turned for further frequency adjustment range. If neither adjustment works, [P] should be selected and the correct printer port address entered. [I]! is then selected to reload the data.

BOARD OPERATION

A computer is connected to the DB-25 connector J9. Data is output from the printer port. The printer card is in slot 0 using the default address in the control program. Data is sent to the PLL device (U1) through the DIP switch (S1), and 74HCT241 buffer (U2). D1, D2, D3, R7, R8, and R12 are in the data path between the 'HCT241 and PLL device. This limits the high level output voltage of the buffer. Voltage on PLL device inputs must be no greater than 0.5 V above V+. A '220 PLL has three output lines which are routed through a 74LS126 line driver (U3) back to the computer.

U2, the 74HCT241, provides isolation and logic translation for PLL input lines. Logic translation is needed from the TTL levels on the printer port to the CMOS levels on the '220 inputs.

A 12 V power supply should be used to power the board at J8 (Augat 2SV-02 connector). The 2SV-02 will accept 18-24 AWG bare copper power leads. No tools are needed for connection. If power is properly connected, LED D4 will be lit.

Power passes from J8 to U5 (LM317 regulator) configured as an 8.5 V regulator. 8.5 V powers the VCOs. Regulators U6 and U7 use the 8.5 V supply to produce 3 V and 5 V. The '220 board can use either to power the logic and charge pump. V+ voltage is selected by J11. U6 and U7 are cascaded with U5 to equalize their individual voltage drops.

The '220 operates in both a single loop and dual loop mode. There are no component changes between the two modes. The differences are in the programming of the counters and the SMA connector that is used.

The PLL loop is composed of the MC145220 (U1), 733 – 743 MHz VCO (M2), and a passive loop filter (R4, R5, C6, C7, C8). In single loop mode, output is taken from J5. A passive loop filter was used to keep the design simple, reduce noise, and reduce the quantity of traces susceptible to stray pickup. The PLL' loop is composed of the MC145220 (U1), 790 – 820 MHz VCO (M3), and a passive loop filter (R22, R25, C24, C26, C30). In single loop mode, output is taken from J10.

Dual mode output is the $(f' - f)$ frequency output from the mixer. It is low pass filtered (L1, L2, C15, C21, C22) then amplified (U4). The output is available at J12.

Phase detector current is 2 mA. J1 is a removable jumper used for current measurement of V+.

Two TCXOs, a Motorola Saber 14.4 MHz (M5), and Raltron 10.01 MHz (M1) are supplied. As shipped from the factory, the 10.01 MHz TCXO is in use. This allows both the 10 kHz and 10 Hz step sizes to be used with one TCXO. 10.01 MHz cannot be divided for larger step sizes such as 100 kHz. For larger step sizes use the Saber. Jumpers J3, J4, J13, and J14 determine which TCXO or the external reference input is in use.

DUAL MODE OUTPUT

The dual mode output (J12) is the difference frequency from mixing PLL and PLL'. By using a reference frequency of 10.01 MHz, PLL can be operated with a 10.01 kHz step size and PLL' with a 10 kHz step size. If both PLL and PLL' step down in frequency, the mixed output will step up by 10 Hz. More information on the offset reference technique is in **AN1277/D, Offset Reference PLLs for Fine Resolution or Fast Hopping**. The block diagram, formulas, and an example are shown in Figure 2.

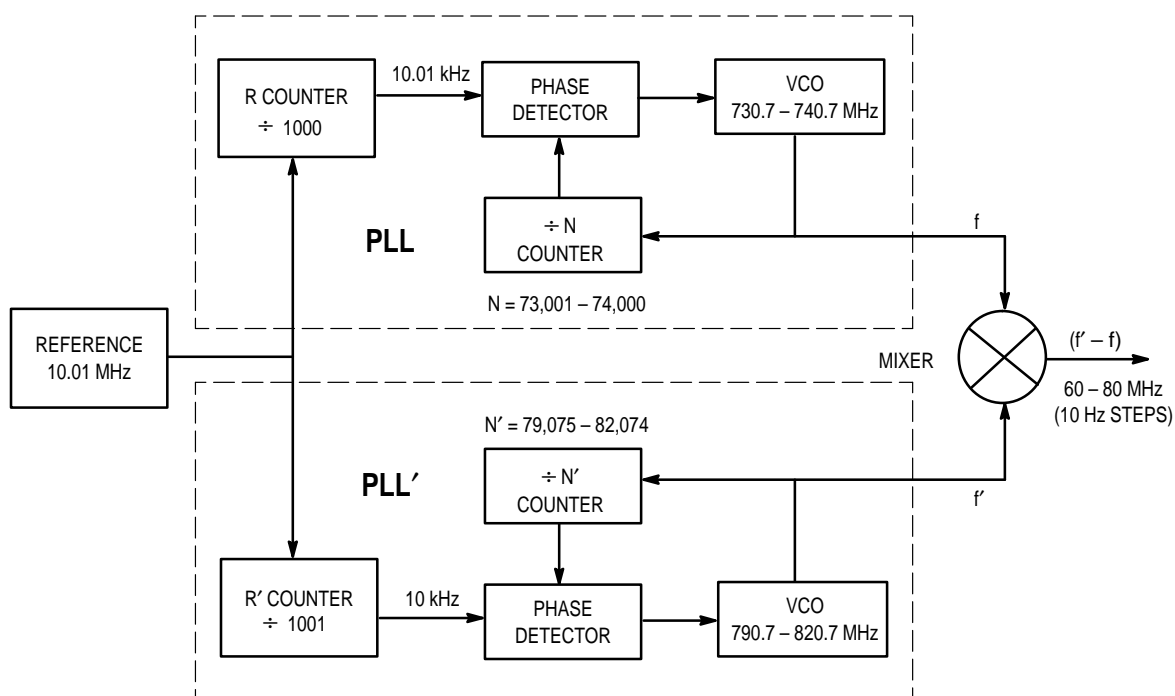

Figure 2. Dual Mode Block Diagram

PLL	PLL'
$f = N (10.01 \text{ kHz})$	$f' = N' (10 \text{ kHz})$
$f = 10.01 \text{ kHz} \left[74,000 - \frac{r(f' - f)}{10 \text{ Hz}} \right]$	$f' = 10 \text{ kHz} \left[\frac{w(f' - f) + 740 \text{ kHz}}{10 \text{ kHz}} + N \right]$
$N = 74,000 - \frac{r(f' - f)}{10 \text{ Hz}}$	$N' = N + 74 + \frac{w(f' - f)}{10 \text{ kHz}}$
$(f' - f) = w(f' - f) + r(f' - f)$	
$(f' - f) = \text{Desired Output Frequency}$	
$w(f' - f) = \text{Output Frequency Portion that Divides Evenly by 10 kHz}$	
$r(f' - f) = \text{Remainder from Output Frequency Division by 10 kHz}$	

Dual Mode Formulas

Example: Synthesize 76.849 930 MHz

$$r(f' - f) = 9.930 \text{ kHz},$$

$$w(f' - f) = 76.840 \text{ MHz}$$

$$N = 74,000 - \frac{9.930 \text{ kHz}}{10 \text{ Hz}} = 73,007$$

$$f = 73,007 (10.01 \text{ kHz}) = 730.800 070 \text{ MHz}$$

$$N' = 73,007 + 74 + \frac{76.840 \text{ MHz}}{10 \text{ kHz}} = 80,765$$

$$f' = 80,765 (10 \text{ kHz}) = 807.650 000 \text{ MHz}$$

$$(f' - f) = 807.650 000 \text{ MHz} - 730.800 070 \text{ MHz} = 76.849 930 \text{ MHz}$$

EXTERNAL REFERENCE INPUT

To use an external reference, disconnect J3, J4, J13, and J14. Use a reference signal at J2 which complies with data sheet requirements. Then modify the reference frequency in the program main menu to reflect the changes made (F menu item).

DATA TRANSFER FROM COMPUTER TO EVK

To control the serial input EVK with the parallel printer port, a conversion is done. Printer cards are designed to output eight bits through eight lines. A bit mask is used to obtain the bit combination for the three required output lines (Data, Clock, Load). As bytes are sent to the printer card in sequence, it appears to be a serial transfer. The printer port is used because data transfer using the serial port would be much slower. A standard IBM PC can support a parallel port data rate of 4.77 MHz.

IBM PCs and compatibles can accept up to three printer port configurations. These ports are called LPT1, LPT2, and LPT3. Each printer port has a unique address. Two sets of addresses are in common use. One set applies to IBM PC XT, AT, and clones. The other is for the PS 2 line. To load data into the EVK, the correct address must be selected. The program default is \$278. If \$278 is not the address in use, it must be modified by entering the P menu item in the main menu. All allowed addresses given in hexadecimal are as follows:

Label	IBM PC and Clones	PS 2
LPT1	278	3BC
LPT2	378	378
LPT3	3BC	278

Up to three EVK boards can operate independently from one printer port. All lines on the printer port are connected to every EVK. Even with three boards operating, only three output lines (Clock, Data, and Load) from the printer card are used. If two boards are controlled together, data for the second board is received from the Output A of the first. Output A is a configurable output on '220 devices, which in this case is used to shift data through chip 1 into chip 2. Output A and Data are connected using a printer port input line. This was done to avoid connecting extra wires. Fortunately not all port input lines are needed for computer input. Load and Clock are common to both boards.

A three-board cascade is handled similarly to a two-board cascade. Out A on the first board is fed to Data on the second. Out A on the second connects to Data on the third. Instructing the program on the quantity of boards connected together allows it to modify the number of bits sent.

All boards have a DIP switch S1 which gives each a unique address. The configuration menu is used to tell the program what type of board is connected at a board address. Switch positions for all possible addresses are given in Figure 3.

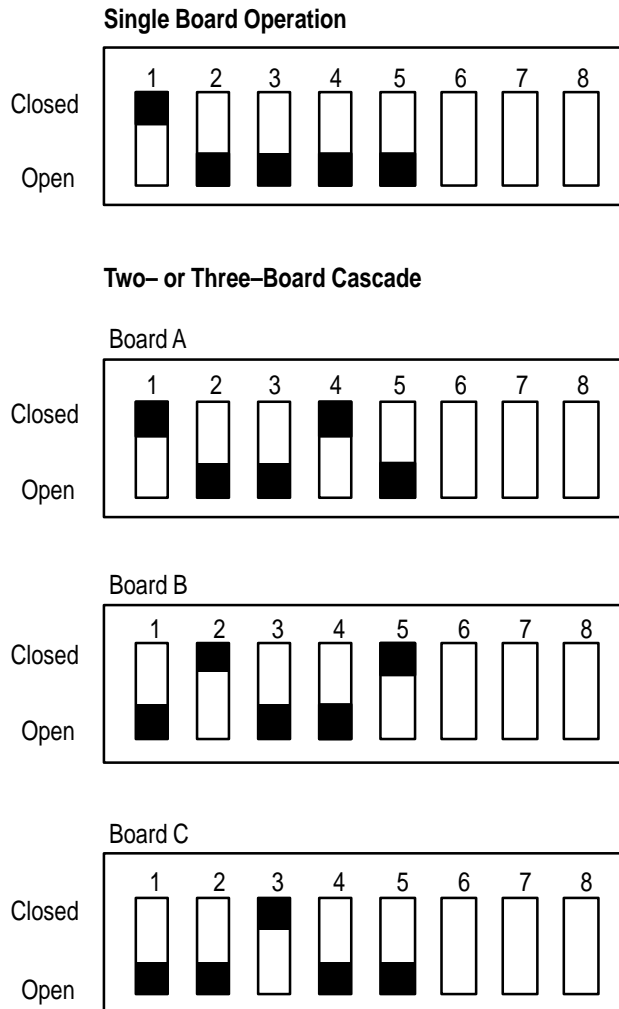

Figure 3. Switch Positions

In Figure 3, DIP switch sections 6, 7, and 8 allow the computer to read Out A, Lock Detect, or Lock Detect from the PLL device. Each of the inputs can only be read on one board at a time, but each item could be read on a different board. In a three-board cascade, Out A could be read from the first board, Out B from the second, and Lock Detect from the third. There is no way to determine the board address of a particular input with software. The control program does not make use of these inputs; however, source code could be modified as required. Pin assignment on the printer port connector is:

Label	Pin Number
Out A	12
Out B	13
Lock Detect	15

PRINTER PORT CONFIGURATION

Printer port outputs on an IBM PC or clone use TTL–LS logic levels. Inputs are one TTL–LS load. Signal lines can be used for any purpose. The standard names, direction of data flow, true and inverted data are shown in Figure 4.

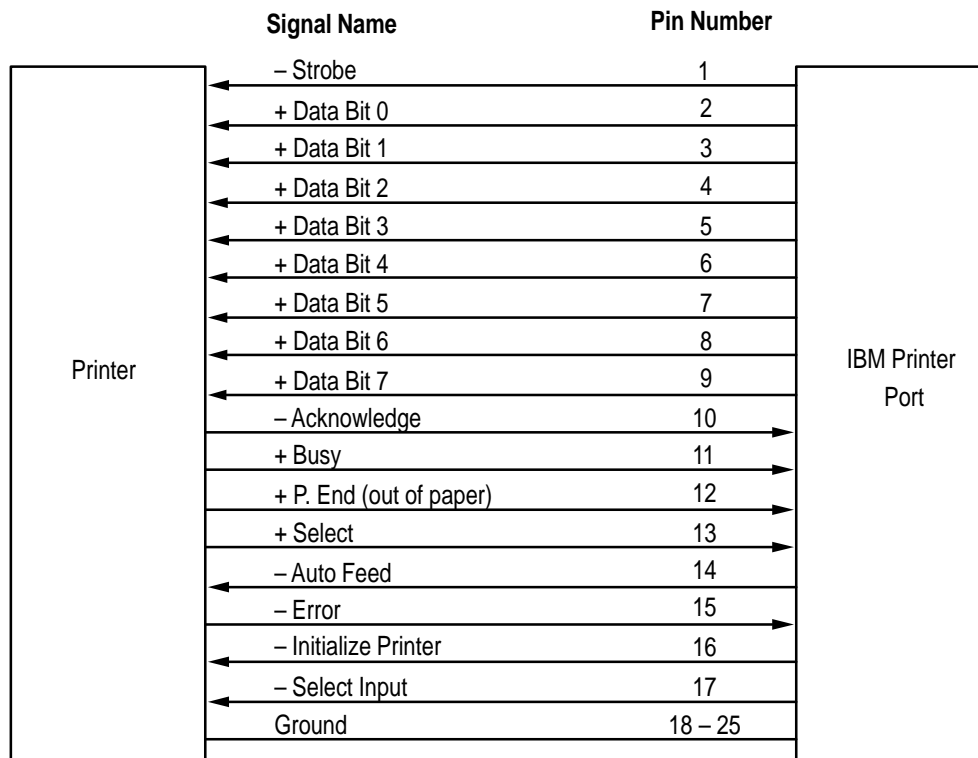

Figure 4. Printer Port Data Lines

Pin numbers for the port connector are shown in Figure 5.

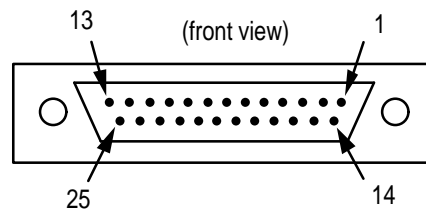

Figure 5. DB–25 Male Connector

SECTION 2 – SOFTWARE DESCRIPTIONS

INTRODUCTION

The MC145xxx PLL software is provided to demonstrate the capabilities of the MC145xxx family of PLLs. The family includes the following devices:

Table 1.

Board Type	Board Description
MC145190	
MC145191	
MC145192	Low voltage version of the '191
MC145200	
MC145201	
MC145202	Low voltage version of the '201
MC145220 in Single Loop Mode	
MC145220 in Dual Loop Mode	

PURPOSE

The user guide for the MC145xxx PLL software familiarizes the user with the use and capabilities of the program referred from here on as PLLDEMO Version 4.0. The guide covers the user interface and a summary of the commands that are available.

The user should read the data sheet of the PLL frequency synthesizer of interest before using the software.

DESCRIPTION

The PLL software:

- is a Pascal program developed with Borland Turbo Pascal v7.0.
- runs under MS-DOS.
- is a character-based, menu-driven program.

USER INTERFACE

The user interface consists of numerous character-based, menu-driven screens which are displayed below. Each screen is shown, along with a description of its purpose. Note that all screen shots shown are a representative sample of the program. They are provided to familiarize the end user with the program.

INSTALL

To install this program, create a directory called "PLLEVAL". Change directories into "PLLEVAL" and copy PLL.exe into this directory.

UNINSTALL

To uninstall this program, change directories into "PLLEVAL" and type "erase*.*". After this command, change out of directory "PLLEVAL" and type "erase PLLEVAL".

Note: If you are in Windows 3.X or Windows 95, this program adds no entries into .ini or Registry files.

It is recommended that you have the PLL program running while you are reviewing this manual. Due to the number of screens that may be involved in your evaluation, following the connections, screens, and commands is easier when the manual and program are used together.

CONVENTIONS

Some of the PLLDEMO screens are necessarily "busy". Because of this, the program follows several conventions to help the user quickly absorb the screen information. These conventions are briefly described on a help screen that is available throughout the program. Type the help command, [?], at any time to view the help screen.

The conventions are as follows:

1. Command keys are surrounded by []s. Type the letter between the []s to execute the command. []s are followed by a description of the command.
2. [-] indicates a command not available to the user. Commands become available when they are applicable to the currently targeted board.
3. []s followed by an ! indicate the command will execute immediately. Otherwise a submenu is displayed from which further choices may be made.
4. If no changes are desired to an input field, leave the field blank. The previous value will then be used for that field. Type the TAB key to move to the next input field, or shift-TAB to move to the prior input field. Type RETURN to store the new input values while remaining on the same screen. Type Q to store the new values and return to the prior screen.
5. All numbers are entered as decimal values unless otherwise noted. A \$ followed by a value indicates the value is in hexadecimal format. The output port address is in hexadecimal format.
6. The second line from the top of screen (screen title) states the purpose of the screen.
7. Screen information that can be changed by the user is displayed in bold or reverse video.
8. Commands are case independent. X is the same as x.
9. Frequencies are entered as two numbers, and displayed as one. The two input numbers represent the desired frequency in MHz, and in kHz. These input values are added together to obtain the final frequency. Leave either input field blank to retain the prior value for that portion of frequency.

ALERT AND ERROR MESSAGES

This program contains two types of messages that appear when conditions warrant. (See Table 2.)

1. **Alert Messages.** These messages alert you that though the current values are valid, you are unable to continuously increment the A and N counters. Hit any key to remove these messages and continue with the program. There are some instances of the alert messages where you may have to hit any key twice to remove the message.
2. **Error Messages.** These are messages that indicate you have selected conditions that are outside of the valid parameters of the IC. After hitting any key to continue, the invalid parameters you selected will change back to the default parameters of the program. You may then enter another value to continue your evaluation. There are some error messages where you may have to hit any key twice to remove the message.

Table 2. Error Messages

Category	Validation Requirements	Corresponding Error Message
REF _{in} Frequency*	1) Value must be ≤ 27 MHz and ≥ 1 MHz	REF _{in} frequency must be ≥ 1 MHz and ≤ 27 MHz
	2) Divide ratio (value converted to kHz/step size in kHz):	
	a) Must be ≤ 8191	REF _{in} /channel spacing must be ≤ 8191
	b) Must be an integer (there must be no fractional result of the division)	REF _{in} frequency is not a multiple of the step size
	c) Must be in range:	
	i) = 1 or ≥ 5 ('190, '191, '192, '200, '201, '202)	REF _{in} /channel spacing must be ≥ 5 or 1
	ii) = 1 or be ≥ 10 ('220S, '220D)	REF _{in} /channel spacing must be ≥ 10 or 1
Step Size*	1) Value must be:	
	a) ≥ 120 Hz and ≤ 2 MHz ('190, '191, '200, '201, '202)	Step size must be ≥ 120 Hz and ≤ 2 MHz
	b) ≥ 120 Hz and ≤ 1 MHz ('192, '220S, '220D)	Step size must be ≥ 120 Hz and ≤ 1 MHz
VCO Frequencies	1) Value must be:	
	a) ≥ 100 MHz and ≤ 1100 MHz ('190, '191, '192)	VCO frequency must be ≥ 100 MHz and ≤ 1100 MHz
	b) ≥ 500 MHz and ≤ 2000 MHz ('200, '201, '202)	VCO frequency must be ≥ 500 MHz and ≤ 2000 MHz
	c) ≥ 40 MHz and ≤ 1100 MHz ('220S)	VCO frequency must be ≥ 40 MHz and ≤ 1100 MHz
	d) ≥ 60 MHz and ≤ 80 MHz ('220D)	VCO frequency must be ≥ 60 MHz and ≤ 80 MHz (limited by EVK)
	2) Divide ratio (value converted to kHz/step size in kHz) must be an integer (this step skipped for '220D)	VCO frequency is not evenly divisible by current step size –OR– VCO frequency is not evenly divisible by current step size (freq. now n/a)
	3) N Counter must be ≥ A Counter (this step skipped for '220D)	Divide ratio is invalid, N Counter must be ≥ A Counter –OR– Divide ratio is invalid, N Counter must be ≥ A Counter (freq. now n/a)

Continued on next page

Continued from previous page

Category	Validation Requirements	Corresponding Error Message
VCO Frequencies	4) Divide ratio must be: (this step skipped for '220D)	
	a) $\leq 262,143$ ('190, '191, '192, '200, '201, '202, '220S with prescale = 64)	Illegal A and N Counter divide value, value must be $\leq 262,143$ –OR– Illegal A and N Counter divide value, value must be $\leq 262,143$ (freq. now n/a)
	b) $\leq 131,071$ ('220S with prescale = 32)	Illegal A and N Counter divide value, value must be $\leq 131,071$ –OR– Illegal A and N Counter divide value, value must be ≤ 131.071 (freq. now n/a)
Step Up or Step Down	1) VCO output frequency $\lt \gt - 999.99$ (this is the number used to represent n/a)	VCO frequency is invalid

*NOTE: REF_{in} and step size are NOT validated on the '220D board. These validation sequences may not be appropriate for the MC145220D.

Table 3. Alert Messages

Category	Validation Requirements	Corresponding Alert Message
VCO Frequencies	1) Divide ratio must be (violation produces only an alert message, value is allowed): (this step skipped for '220D)	
	a) ≥ 4032 ('190, '191, '192, '200, '201, '220S with prescale = 64)	A and N Counter divide value is < 4032 , may be gaps in band coverage
	b) ≥ 992 ('220S with prescale = 32)	A and N Counter divide value is < 992 , may be gaps in band coverage

SCREENS

'Define boards to program'

The first screen the user sees when the program begins has a screen title of 'Define boards to program'. This screen is used to define which boards are connected to the LPT1 printer port of the computer. Refer to the hardware setup section to determine how to cascade the evaluation boards.

This screen is also available from the main menu. The user may return to this screen by depressing [Q] to change the boards that are connected to the computer.

The screen is divided into two sections. The upper section shows the current board type settings while the lower section allows the user to define a board's type and position in the cascade connection.

Notice the section labeled 'Available Boards:' shows three labels, one for each board that may be cascaded. When the program first starts up it shows 'N/A' (not applicable) after each label. The user must enter the boards contiguously. Initially the program requests for the user to enter board A's type. This is signified by **A** (in the screen below) being set to A. The user can select the board type for board A by typing the corresponding command.

Once board A's type is selected, **A** automatically increments to B and the process may be repeated. Once all boards have been correctly defined, the user may select [Q] which sends default data to the boards and continues to the next screen. NOTE: Before selecting [Q], the user should insure that the DIP switch settings shown in Figure 2 are correct.

If a board is incorrectly identified, select the board that is not correctly defined by typing the corresponding board letter ([A], [B], or [C]). The user may then reselect the board's type. Once the board has been identified, the user may select the letter ([A], [B], or [C]) of the board followed by [S] to change hardware-dependent variables for that board.

[X] can be selected to exit the program completely. [?] can be selected to view the help screen.

```

                                     Welcome to MC145xxx EVK Demonstration Program, rev 4.0
                                     Define boards to program

Available Boards:
  Brd [A]!: N/A                      Brd [B]!: N/A                      Brd [C]!: N/A
-----

Board A is:

  [-]! no board                      [5]! MC145201
  [1]! MC145190                      [6]! MC145202
  [2]! MC145191                      [7]! MC145220 Single
  [3]! MC145192                      [8]! MC145220 Dual
  [4]! MC145200

  [-] Boards defined, Continue

[X]! Terminate demonstration program. [?! View help screen.
```

Help Screen

This is the help screen for the program. It is available from any point throughout the program. A short list of the interface conventions are presented on this screen.

[X] can be selected to exit the program completely. [Q] can be selected to exit the help screen.

```

                Welcome to MC145xxx EVK Demonstration Program, rev 4.0

1) Command keys are surrounded by []'s. Type the letter between the []'s to execute
   the command. []'s are followed by a description of the command.

2) [-] indicates a command not available to the user.

3) []'s followed by an ! indicate the command will execute immediately. Otherwise a
   sub menu will be displayed.

4) If no changes are desired to an input field, type the TAB key to move to the next
   input field. The previous value will be used for that field.

5) All numbers are entered as decimal values unless otherwise noted. A $ followed by a
   value indicates the value is in hexadecimal format.

6) The second line from the top of screen (screen title) states the purpose of the
   screen.

7) Screen information that can be changed by the user is displayed in bold or reverse
   video.

8) Commands are case independent. X is the same as x.

                [X]! Terminate demonstration program. [Q]! Quit help screen.
```

To access this screen, press shift + ? on your keyboard while within any screen in the program.

‘Select from the available options’

This is the main screen of the program. This is where the user enters commands to demonstrate the capabilities of the various boards connected to the computer. The title of the screen is ‘Select from the available options’.

This screen is broken down into three sections:

‘Available Boards’

This section displays the board types that are connected to the computer. It also designates which board is the currently selected ‘target’ board. This is the board that will receive the commands from ‘MC145xxx Commands’ section. This section also provides the ability to change the targeted board. Type the target board command ([A], [B], or [C]) to target that particular board.

‘MC145xxx Commands’

This section is further divided into three subsections. Each subsection contains commands that can be sent to the ‘target’ board to demonstrate its capabilities. Each of these commands is described in full in the Command Summary.

The first subsection, ‘MC145xxx Frequency Commands’, contains commands that are used to modify the PLL frequency in some way. These commands are available for all possible target board types.

In the top line of this section, ‘Current Output Frequency is **70 MHz**’ designates what the frequency is for the currently targeted board. This value is dynamic.

On the lines below this, **60 MHz** is the current setting for the default low frequency. **70 MHz** is the current setting for the default medium frequency. **80 MHz** is the current setting for the default high frequency.

The second subsection, ‘MC145xxx Additional Commands’, contains commands that are used to further modify the currently targeted board. These commands also work with all of the MC145xxx board types.

The third subsection, ‘MC145220 EVK – Single Specific Commands’, are only displayed when the MC145220EVK in single loop mode is the currently targeted board. This section shows commands that are specific to this board. This is required since this board contains the equivalent of two PLLs.

The command letter for ‘Set target PLL on board’ is [T]!. In single loop mode, the user may toggle between PLL and PLL’ on the MC145220EVK by using this command. Feedback is given to the user as to whether PLL or PLL’ will be accessed. See near the top of the screen on the line titled “Available Boards - Current target board is: ...”

‘Initialization/System Setup Commands’

This section contains commands that are used to initialize all boards connected to the computer or to set up the computer.

'Select from the available options' (continued)

```

Welcome to MC145xxx EVK Demonstration Program, rev 4.0
Select from the available options

Available Boards - Current target board is: A, MC145220 Dual
Brd [A]!: MC145220 Dual   Brd [-]!: N/A           Brd [-]!: N/A
-----
MC145xxx Frequency Commands - Current Output Frequency is 70 MHz
[L]! Set to low freq.      60 MHz [W] Change default low freq.
[M]! Set to med. freq.     70 MHz [Y] Change default med. freq.
[H]! Set to high freq.     80 MHz [Z] Change default high freq.
[U]! Step frequency up by step size   [O] Set PLL output frequency
[D]! Step frequency down by step size [F] REFin freq. & channel spacing
MC145xxx Additional Commands
[E] Set function of output A           [N] Change C register and Prescale
[R] Set crystal/reference mode - Current mode is Ref. mode, REFout low
-----
Initialization/System Setup Commands:
[P] Set output port address - Current address is $278
[G] Change board definitions
[I] Initialize board(s), Write all registers

[X]! Terminate demonstration program. [?! View help screen.
```

This screen shot is a representative sample of the screens within this program. To access this screen with the MC145220 Dual EVK selected in the "Define boards to program" screen, press [Q]! . This will place you in the "Select from the available options" screen you see above.

This sequence to access the "Select from the available options" screen works the same for any selected board in the "Define boards to program" screen.

PLL Output Frequency

This is the resulting screen that is displayed after the user selects the '[O] Set PLL output frequency' command. The user is prompted to enter the new frequency.

The current output frequency is automatically retained if the user hits return or [Q] without entering a value.

```

Welcome to MC145xxx EVK Demonstration Program, rev 4.0
Set PLL output frequency

Available Boards - Current target board is: A, MC145220 Dual
  Brd [A]!: MC145220 Dual   Brd [-]!: N/A           Brd [-]!: N/A
-----

Input new frequency in integer values of MHz, kHz, and Hz.

Original program default PLL output frequency is 70 MHz
Current PLL output frequency is 70 MHz

Original program default frequency range is 60 MHz to 80 MHz
Current frequency range is 60 MHz to 80 MHz
Frequencies outside the program default frequency range will NOT be accepted.

New PLL frequency: 70 MHz + 000 kHz + 000 Hz

[TAB] to move to next field
[Q]   to return to main menu

[X]! Terminate demonstration program. [?!] View help screen.
```

This screen shot is a representative sample of the screens within this program. To access this screen with the MC145220 Dual EVK selected in the "Define boards to program" screen, press [Q]! . This will place you in the "Select from the available options" screen. To access the screen shown above, press [O].

This sequence to access the "Set PLL output frequency" screen works the same for any selected board in the "Define boards to program" screen.

REF_{in} Frequency and Channel Spacing

This is the resulting screen that is displayed after the user selects the '[F] Set REF_{in} freq. and channel spacing' command. The user is prompted to enter the new REF_{in} frequency and channel spacing values, or leave the fields blank to retain the prior settings. In '220 dual mode, the user does not have the option of changing REF_{in} frequency or channel spacing.

```

Welcome to MC145xxx EVK Demonstration Program, rev 4.0
REFin frequency and channel spacing

Available Boards - Current target board is: A, MC145220 Dual
Brd [A]!: MC145220 Dual   Brd [-]!: N/A           Brd [-]!: N/A
-----

Due to the complexity of error checking in Dual Mode,
REFin frequency may not be modified.
The REFin frequency is 10.01 MHz

Due to the complexity of error checking in Dual Mode,
channel spacing may not be modified.
The channel spacing is 10 Hz

[Q] to return to main menu

[X]! Terminate demonstration program. [?! View help screen.
```

This screen shot is a representative sample of the screens within this program. To access this screen with the MC145220 Dual EVK selected in the "Define boards to program" screen, press [Q]! . This will place you in the "Select from the available options" screen. To access the screen shown above, press [F].

This sequence to access the "REF_{in} frequency and channel spacing" screen works the same for any selected board in the "Define boards to program" screen.

Set Default Low Frequency

This is the resulting screen that is displayed after the user selects the '[W] Change default low freq.' command. The user is prompted to enter the new default low frequency value.

Entering a new value does not change the current output frequency of the target board. Changing the low frequency simply adjusts the low frequency setting available from the main menu. The '[L]! Set to low freq.' command changes the current output frequency.

The screen is similar for the Y and Z commands except that the prompts specify medium or high frequency, respectively.

```

                                     Welcome to MC145xxx EVK Demonstration Program, rev 4.0
                                     Set default low frequency

Available Boards - Current target board is: A, MC145220 Dual
  Brd [A]!: MC145220 Dual   Brd [-]!: N/A           Brd [-]!: N/A
-----

Input new default low frequency in integer values of MHz, kHz, and Hz.

Original program default low frequency is 60 MHz
Current low frequency is 60 MHz

New default low frequency: 60 MHz + 000 kHz + 000 Hz

[TAB] to move to next field
[Q]   to return to main menu

                                     [X]! Terminate demonstration program. [?!] View help screen.
```

This screen shot is a representative sample of the screens within this program. To access this screen with the MC145220 Dual EVK selected in the "Define boards to program" screen, press [Q]! . This will place you in the "Select from the available options" screen. To access the screen shown above, press [W].

This sequence to access the "Set default low frequency" screen works the same for any selected board in the "Define boards to program" screen.

Set Function of Output A

This is the resulting screen that is displayed after the user selects the '[E] Set function of Output A' command. The user is provided a submenu to select from.

The current setting for the function of Output A is displayed as Port, Data Out, fv or fr. The user may choose from the listed commands to adjust this setting.

```

Welcome to MC145xxx EVK Demonstration Program, rev 4.0
Set function of Output A

Available Boards - Current target board is: A, MC145220 Dual
  Brd [A]!: MC145220 Dual   Brd [-]!: N/A           Brd [-]!: N/A
-----

Set Output A function - Currently: Data Out
[0]! Port
[1]! Data Out
[2]! fv
[3]! fr

[Q] to return to main menu

[X]! Terminate demonstration program. [?! View help screen.
```

This screen shot is a representative sample of the screens within this program. To access this screen with the MC145220 Dual EVK selected in the "Define boards to program" screen, press [Q]! . This will place you in the "Select from the available options" screen. To access the screen shown above, press [E].

This sequence to access the "Set function of Output A" screen works the same for any selected board in the "Define boards to program" screen.

Change C Register and Prescale

This is the resulting screen that is displayed after the user selects the '[N] Change C Register and Prescale' command. The user is provided a submenu to select from. Each submenu option also shows a submenu. Note that in '220 dual mode, some options are deleted. This is notated with the [-] symbol.

```

Welcome to MC145xxx EVK Demonstration Program, rev 4.0
Change C Register and Prescale

Available Boards - Current target board is: A, MC145220 Dual
Brd [A]!: MC145220 Dual   Brd [-]!: N/A           Brd [-]!: N/A
-----

Change C register:
[-] PDout Current Step Size
[-] Output B - (Out B)
[2] PDout Current - (PDout)
[3] Phase Detector Select - (PDA/B)
[-] Lock Detect Enable - (LDE)
[5] Phase Detector Polarity - (POL)
[6] Standby - (STBY)

Change Prescale:
[7] Prescale

[Q] to return to main menu

[X]! Terminate demonstration program. [?! View help screen.
```

This screen shot is a representative sample of the screens within this program. To access this screen with the MC145220 Dual EVK selected in the "Define boards to program" screen, press [Q]! . This will place you in the "Select from the available options" screen. To access the screen shown above, press [N].

Change C Register, PD_{Out} Current

This is the resulting screen that is displayed after the user selects the '[N] Change C Register and Prescale' and then the '[2] Change PD_{Out} Current' command. The user is provided a submenu to select from. This submenu contains commands to change the PD_{Out} current settings.

The screen is slightly different depending on whether Output A is defined as a port or not. See command [E] from the main menu. Note in '220 dual mode, PD_{Out} current for PLL and PLL' is modified simultaneously by the software program.

The current PD_{Out} setting is displayed as '5%', '50%', '80%', or '100%'.

The user can select the [0], [1], [2], and [3] menu options to change the percent of PD_{Out} current.

If the [Q] command is selected, then the user is returned to the main menu.

```

                Welcome to MC145xxx EVK Demonstration Program, rev 4.0
                Change C Register, PDout Current

Available Boards - Current target board is: A, MC145220 Dual
Brd [A]!: MC145220 Dual      Brd [-]!: N/A              Brd [-]!: N/A
-----

Evaluation program modifies PDout Current on both PLL's for this board.

Change C Register, PDout Current - Currently: 100%
[0]! 5%
[1]! 50%
[2]! 80%
[3]! 100%

[Q] to return to previous menu

[X]! Terminate demonstration program. [?! View help screen.
```

This screen shot is a representative sample of the screens within this program. To access this screen with the MC145220 Dual EVK selected in the "Define boards to program" screen, press [Q]! . This will place you in the "Select from the available options" screen. In this screen, press [N]. This will place you in the "Change C Register and Prescale" screen. To access the screen above, press [2].

Change C Register, Phase Detector Select

This is the resulting screen that is displayed after the user selects the '[N] Change C Register and Prescale' and then the '[3] Change phase detector select' command. The user is provided a submenu to select from. This submenu contains commands to toggle the phase detector setting.

The current phase detector setting is displayed as 'phi R & phi V' or 'PD_{out}', depending on the setting.

The user can select the [0] and [1] menu options to toggle the phase detector select setting.

If the [Q] command is selected, then the user is returned to the main menu.

```

                Welcome to MC145xxx EVK Demonstration Program, rev 4.0
                Change C Register, Phase Detector Select

Available Boards - Current target board is: A, MC145220 Dual
Brd [A]!: MC145220 Dual   Brd [-]!: N/A           Brd [-]!: N/A
-----

Evaluation program modifies Phase Detector Select on both PLL's for this board.

Change C Register, Phase Detector Select - Currently: PDout
[0]! phi R & phi V, phi R' & phi V'
[1]! PDout, PDout'

[Q] to return to previous menu

[X]! Terminate demonstration program. [?! View help screen.
```

This screen shot is a representative sample of the screens within this program. To access this screen with the MC145220 Dual EVK selected in the "Define boards to program" screen, press [Q]! . This will place you in the "Select from the available options" screen. In this screen, press [N]. This will place you in the "Change C Register and Prescale" screen. To access the screen above, press [3].

This sequence to access the "Change C Register, Phase Detector Select" screen works the same for any selected board in the "Define boards to program" screen.

Change C Register, Polarity

This is the resulting screen that is displayed after the user selects the '[N] Change C Register and Prescale' and then the '[5] Change polarity of phase detector' command. The user is provided a submenu to select from. This submenu contains commands to toggle the polarity setting.

The default '220 dual setting of the polarity is displayed as 'Non-invert PD_{Out} and PD_{Out}', do not interchange phi R, R' & phi V, V'.

The user can select the [0] and [1] menu options to toggle the polarity setting.

If the [Q] command is selected, then the user is returned to the main menu.

```

                                Welcome to MC145xxx EVK Demonstration Program, rev 4.0
                                Change C Register, Polarity

Available Boards - Current target board is: A, MC145220 Dual
Brd [A]!: MC145220 Dual   Brd [-]!: N/A           Brd [-]!: N/A
-----

Evaluation program modifies Polarity on both PLL's for this board.

Change C Register, Polarity - Currently: Non-invert PDout
[0]! Non-invert PDout and PDout', do not interchange phi R, R' & phi V, V'
[1]! Invert PDout and PDout', interchange phi R, R' & phi V, V'

[Q] to return to previous menu

[X]! Terminate demonstration program. [?! View help screen.
```

This screen shot is a representative sample of the screens within this program. To access this screen with the MC145220 Dual EVK selected in the "Define boards to program" screen, press [Q]! . This will place you in the "Select from the available options" screen. In this screen, press [N]. This will place you in the "Change C Register and Prescale" screen. To access the screen above, press [5].

This sequence to access the "Change C Register, Polarity" screen works the same for any selected board in the "Define boards to program" screen.

Change C Register, Standby

This is the resulting screen that is displayed after the user selects the '[N] Change C Register and Prescale' and then the '[6] Change standby' command. The user is provided a submenu to select from. This submenu contains commands to toggle the standby state setting.

The standby state setting is displayed as 'Normal operation' or 'Standby', depending on the current setting.

The user can select the [0] and [1] menu options to toggle the standby state setting.

If the [Q] command is selected, then the user is returned to the main menu.

```

                Welcome to MC145xxx EVK Demonstration Program, rev 4.0
                Change C Register, Standby

Available Boards - Current target board is: A, MC145220 Dual
  Brd [A]!: MC145220 Dual   Brd [-]!: N/A           Brd [-]!: N/A
-----

Evaluation program modifies Standby on both PLL's for this board.

Change C Register, Standby - Currently: Normal Operation
  [0]! Normal operation
  [1]! Standby

  [Q] to return to previous menu

[X]! Terminate demonstration program. [?! View help screen.
```

This screen shot is a representative sample of the screens within this program. To access this screen with the MC145220 Dual EVK selected in the "Define boards to program" screen, press [Q]! . This will place you in the "Select from the available options" screen. In this screen, press [N]. This will place you in the "Change C Register and Prescale" screen. To access the screen above, press [6].

This sequence to access the "Change C Register, Standby" screen works the same for any selected board in the "Define boards to program" screen.

Set Output Port Address

This is the resulting screen that is displayed after the user selects the '[P] Set output port address' command. The user is prompted to enter the new output port address in hexadecimal. This should be the port address of the LPT1 printer port for the user's computer.

The original program default port address and the current setting are displayed.

Enter the new output port address in hexadecimal format.

```

Welcome to MC145xxx EVK Demonstration Program, rev 4.0
Set output port address

Available Boards - Current target board is: A, MC145220 Dual
  Brd [A]!: MC145220 Dual   Brd [-]!: N/A           Brd [-]!: N/A
-----

Input new output port address in hexadecimal.

Original program default port address is $278
Current port address is $278

New output port address: $278

[Q] to return to main menu

[X]! Terminate demonstration program. [?! View help screen.
```

This screen shot is a representative sample of the screens within this program. To access this screen with the MC145220 Dual EVK selected in the "Define boards to program" screen, press [Q]! . This will place you in the "Select from the available options" screen. To access the screen above, press [P].

This sequence to access the "Set output port address" screen works the same for any selected board in the "Define boards to program" screen.

Set Crystal or Reference Mode

This is the resulting screen that is displayed after the user selects the '[R] Set crystal/reference mode' command. The user is provided a submenu to select from. This submenu contains commands to change the crystal/reference mode.

The current reference mode is displayed as 'Crystal mode, Shutdown'; 'Crystal mode, Active'; 'Reference mode, REF_{in} enabled, REF_{out} low'; 'Reference mode, REF_{out} = REF_{in}'; 'Reference mode, REF_{out} = REF_{in}/2'; 'Reference mode, REF_{out} = REF_{in}/4'; 'Reference mode, REF_{out} = REF_{in}/8'; or 'Reference mode, REF_{out} = REF_{in}/16', depending on the current setting.

The user can select the [0] to [7] menu options to change the crystal/reference mode setting.

If the [Q] command is selected, then the user is returned to the main menu.

```

                                     Welcome to MC145xxx EVK Demonstration Program, rev 4.0
                                     Set crystal or reference mode

Available Boards - Current target board is: A, MC145220 Dual
Brd [A]!: MC145220 Dual      Brd [-]!: N/A              Brd [-]!: N/A
-----

Set crystal or reference mode - Currently: Ref. mode, REFout low
[0]! Crystal mode, Shutdown
[1]! Crystal mode, Active
[2]! Reference mode, REFin enabled, REFout low
[3]! Reference mode, REFout = REFin
[4]! Reference mode, REFout = REFin/2
[5]! Reference mode, REFout = REFin/4
[6]! Reference mode, REFout = REFin/8
[7]! Reference mode, REFout = REFin/16

[Q] to return to main menu

[X]! Terminate demonstration program. [?! View help screen.
```

This screen shot is a representative sample of the screens within this program. To access this screen with the MC145220 Dual EVK selected in the "Define boards to program" screen, from within the "Define boards to program" screen, press [Q]! . This will place you in the "Select from the available options" screen. Select [R], which will place you in the "Set crystal or reference mode" screen you see above.

This sequence to access the "Set crystal or reference mode" screen works the same for any selected board in the "Define boards to program" screen.

SECTION 3 – COMMAND SUMMARY

[A]! Set board A as target

To access this command in the program, at the DOS prompt, type “PLL”. This is the opening default screen.

See page 18 of this document for a sample screen shot of this command.

This command sets the target board to the board shown as A. This means that the commands that follow will affect board A only. The user is informed of, and may modify, the target board in any screen of the program except the help screen.

This is strictly an internal program command and has no effect on the MC145xxx EVKs connected to the computer.

[B]! Set board B as target

To access this command in the program, at the DOS prompt, type “PLL”. This is the opening default screen.

See page 18 of this document for a sample screen shot of this command.

This command sets the target board to the board shown as B. This means that the commands that follow will affect board B only. The user is informed of, and may modify, the target board in any screen of the program except the help screen.

This is strictly an internal program command and has no effect on the MC145xxx EVKs connected to the computer.

[C]! Set board C as target

To access this command in the program, at the DOS prompt, type “PLL”. This is the opening default screen.

See page 18 of this document for a sample screen shot of this command.

This command sets the target board to the board shown as C. This means that the commands that follow will affect board C only. The user is informed of, and may modify, the target board in any screen of the program except the help screen.

This is strictly an internal program command and has no effect on the MC145xxx EVKs connected to the computer.

[L]! Set to low freq.

To access this command in the program, select a board in the “Define boards to program” screen and then press [Q]! . This will place you in the “Select from the available options” screen. The command [L]! is on this screen.

See page 21 of this document for a sample screen shot of this command.

This command is used to set the frequency of the currently selected board to the currently defined low value. This value can be changed via the [W] command.

This is accomplished by correctly adjusting the A register for the targeted board.

If the current EVK is the MC145220 and the board is in DUAL mode, then the currently targeted PLL on the board is set to the specified low frequency. Otherwise, if the board is in SINGLE mode, both on-board PLLs are set to the new frequency.

[M]! Set to medium freq.

To access this command in the program, select a board in the “Define boards to program” screen and then press [Q]! . This will place you in the “Select from the available options” screen. The command [M]! is on this screen.

See page 21 of this document for a sample screen shot of this command.

This command is used just as the [L]! command except that the defined medium frequency value is used. This default value can be changed by selecting command [N]. Reference [L]! command for further details.

[H]! Set to high freq.

To access this command in the program, select a board in the “Define boards to program” screen and then press [Q]! . This will place you in the “Select from the available options” screen. The command [H]! is on this screen.

See page 21 of this document for a sample screen shot of this command.

This command is used just like the [L]! command except that the defined high frequency value is used. This default value can be changed by selecting command [W]. Reference [L]! command for further details.

[W] Change default low frequency

To access this command in the program, select a board in the “Define boards to program” screen and then press [Q]! . This will place you in the “Select from the available options” screen. The command [W] is on this screen.

See page 21 of this document for a sample screen shot of this command.

This command prompts the user to input a decimal value in MHz for the default low frequency. The program default low value is displayed along with the current value. The user may leave the low frequency value as is by entering return without a value. The program low default value is dependent on the targeted board type. (See Table 4.)

This value is not sent to the board immediately. It is the value that is sent to the board when the [L] command is executed.

Table 4.

Board Type	Program Default Low Frequency
MC145190	741 MHz
MC145191	733 MHz
MC145192	733 MHz
MC145200	1482 MHz
MC145201	1466 MHz
MC145202	1466 MHz
MC145220 in Single Loop Mode	733 MHz (PLL) 790 MHz (PLL')
MC145220 in Dual Loop Mode	60 MHz

[Y] Change default medium frequency

To access this command in the program, select a board in the “Define boards to program” screen and then press [Q]! . This will place you in the “Select from the available options” screen. The command [Y] is on this screen.

See page 21 of this document for a sample screen shot of this command.

This command prompts the user to input a decimal value in MHz for the default medium frequency. The program default medium value is displayed along with the current value. The user may leave the medium frequency value as is by entering return without a value. The program medium default value is dependent on the targeted board type. (See Table 5.)

This value is not sent to the board at this time. It is the value that is sent to the board when the [M] command is executed.

Table 5.

Board Type	Program Default Medium Frequency
MC145190	746 MHz
MC145191	738 MHz
MC145192	738 MHz
MC145200	1492 MHz
MC145201	1476 MHz
MC145202	1476 MHz
MC145220 in Single Loop Mode	738 MHz (PLL) 805 MHz (PLL')
MC145220 in Dual Loop Mode	70 MHz

[Z] Change default high frequency

To access this command in the program, select a board in the “Define boards to program” screen and then press [Q]! . This will place you in the “Select from the available options” screen. The command [Z] is on this screen.

See page 21 of this document for a sample screen shot of this command.

This command prompts the user to input a decimal value in MHz for the default high frequency. The program default high value is displayed along with the current value. The user may leave the high frequency value as is by entering return without a value. The program high default value is dependent on the targeted board type. (See Table 6.)

This value is not sent to the board immediately. It is the value that is sent to the board when the [L] command is executed.

Table 6.

Board Type	Program Default High Frequency
MC145190	751 MHz
MC145191	743 MHz
MC145192	743 MHz
MC145200	1502 MHz
MC145201	1486 MHz
MC145202	1486 MHz
MC145220 in Single Loop Mode	743 MHz (PLL) 820 MHz (PLL')
MC145220 in Dual Loop Mode	80 MHz

[U]! Step frequency up by step size

To access this command in the program, select a board in the “Define boards to program” screen and then press [Q]! . This will place you in the “Select from the available options” screen. The command [U]! is on this screen.

See page 21 of this document for a sample screen shot of this command.

This command increments the NCOUNTER and ACOUNTER fields of the A register for the currently targeted board. This steps up the PLL’s frequency by the current step size for the board.

If the currently selected board is an MC145220 in DUAL mode, then the currently targeted PLL on the board is “stepped”. If the MC145220 is in SINGLE mode, then both PLLs on the board are “stepped”.

[D]! Step frequency down by step size

To access this command in the program, select a board in the “Define boards to program” screen and then press [Q]! . This will place you in the “Select from the available options” screen. The command [D]! is on this screen.

See page 21 of this document for a sample screen shot of this command.

This command decrements the NCOUNTER and ACOUNTER fields of the A register for the currently targeted board. This is the effect of stepping down the PLL’s frequency by the current step size for the board.

If the currently selected board is an MC145220 in DUAL mode, then the currently targeted PLL on the board is “stepped”. If the MC145220 is in SINGLE mode, then both PLLs on the board are “stepped”.

[O] Set PLL output frequency

To access this command in the program, select a board in the “Define boards to program” screen and then press [Q]! . This will place you in the “Select from the available options” screen. The command [O] is on this screen.

See page 21 of this document for a sample screen shot of this command.

This command prompts the user to input a decimal value in MHz and kHz to set the targeted board frequency. The program default PLL output frequency is displayed along with the current value. The user may leave the output frequency value as is by entering return without entering a value. The program validates the entered frequency by checking to ensure that the value is a multiple of the board’s current step size and that the entered frequency / frequency step size is ≥ 4032 . The program accepts total divide values < 4032 if $N \geq A$. (Total divide must be $\leq 262,143$ for all PLLs.)

$N * P + A = \text{total divide}$ ($p = \text{prescale} = 64$ for '191), ($p = \text{prescale} = 32$ or 64 for '220)

A further check is made to ensure that the entered frequency is within the capability of the currently targeted demonstration board. (See Table 7.) Frequencies outside the range are allowed for users who use their own VCO. Note in '220 dual mode, frequencies outside the program default will not be accepted due to the complexity of error checking the results.

Table 7.

Board Type	Minimum Frequency	Maximum Frequency
MC145190	741 MHz	751 MHz
MC145191	733 MHz	743 MHz
MC145192	733 MHz	738 MHz
MC145200	1482 MHz	1502 MHz
MC145201	1466 MHz	1486 MHz
MC145202	1466 MHz	1486 MHz
MC145220 in Single Loop Mode	733 MHz (PLL) 790 MHz (PLL')	743 MHz (PLL) 820 MHz (PLL')
MC145220 in Dual Loop Mode	60 MHz	80 MHz

Once validated, the NCOUNTER and ACOUNTER fields of the A register are appropriately modified to set the PLL frequency for the targeted board to the specified value.

If the currently targeted board is an MC145220 in DUAL mode, then the currently targeted PLL on the board will have its frequency set. If the MC145220 is in single mode, then both PLLs on the board will have their frequencies set.

[F] Set REF_{IN} frequency and channel spacing

To access this command in the program, select a board in the “Define boards to program” screen and then press [Q]! . This will place you in the “Select from the available options” screen. The command [F] is on this screen.

See page 23 of this document for a sample screen shot of this command.

This command prompts the user to input two values. First, a decimal value, in the form of XX MHz + XXX kHz, to set the reference frequency of the targeted board. The program default frequency is displayed along with the current value. The user may leave the reference frequency value as is by entering return. A second input, in the form of XX MHz + XXX kHz, sets the channel spacing (step size) of the targeted board. The program default step size is displayed along with the current value. The user may leave the step size as is by entering return.

The inputs are validated by checking that the step size remains ≤ 2 MHz (≤ 1 MHz for the '220) for all boards. The entered frequency is validated to ensure that the new reference frequency / new step size is < 8191 and is an even multiple of the new channel spacing.

Finally, the RCOUNTER of the R register is set with the value of (new reference frequency / new channel spacing) and R register is written to the targeted board. Then the ACOUNTER and NCOUNTER are reset to the previous frequency using the new channel spacing (previous frequency / new channel spacing) and the A register is written out.

Note that due to the complexity of error checking in dual mode, REF_{IN} frequency and channel spacing may not be modified.

Table 8.

Board Type	Default Reference Frequency	Default Step Size
MC145190	14.4 MHz	100 kHz
MC145191	14.4 MHz	100 kHz
MC145192	14.4 MHz	100 kHz
MC145200	14.4 MHz	200 kHz
MC145201	14.4 MHz	200 kHz
MC145202	14.4 MHz	200 kHz
MC145220 in Single Loop Mode	10.01 MHz	10 kHz
MC145220 in Dual Loop Mode	10.01 MHz	10 Hz (10.01 kHz (PLL), 10 kHz (PLL'))

[E] Set function of output A

To access this command in the program, select a board in the “Define boards to program” screen and then press [Q]! . This will place you in the “Select from the available options” screen. The command [E] is on this screen.

See page 25 of this document for a sample screen shot of this command.

This command displays a submenu with the next four options displayed if the currently targeted board is the last board in the cascade. The user may only change the Output A configuration on the last board in line. The user can select one of the following options to configure the Output A:

[0]! Port

Bits A₂₃ and A₂₂ (A₂₂, A₂₁ on '220) are set to 00 binary while the remaining bits of register A are preserved and the A register is written to the targeted board. Enable the [C][A] command.

[1]! Data Out

Bits A₂₃ and A₂₂ (A₂₂, A₂₁ on '220) are set to 01 binary while the remaining bits of register A are preserved and the A register is written to the targeted board. Disable the [C][A] command.

[2]! fv

Bits A₂₃ and A₂₂ (A₂₂, A₂₁ on '220) are set to 10 binary while the remaining bits of register A are preserved and the A register is written to the targeted board. Disable the [C][A] command.

[3]! fr

Bits A₂₃ and A₂₂ (A₂₂, A₂₁ on '220) are set to 11 binary while the remaining bits of register A are preserved and the A register is written to the targeted board. Disable the [C][A] command.

[N] Change C Register and Prescale

To access this command in the program, select a board in the “Define boards to program” screen and then press [Q]! . This will place you in the “Select from the available options” screen. The command [N] is on this screen.

See page 26 of this document for a sample screen shot of this command.

This command displays a submenu with the next seven options displayed. This is where the user can modify the C register settings.

[0] Change output A – (Port)

To access this command in the program, select a board in the “Define boards to program” screen and then press [Q]! . This will place you in the “Select from the available options” screen. Press [N], which will place you in the “Change C Register” screen. The command [0] is on this screen.

This is only available with Output A configured as a port for the currently targeted board. See [A][0]! command. Command not available in dual mode.

[0]! Reset output A to 0

This resets the PORT field of register C (C1) to 0 and then writes register C to the currently targeted board.

[1]! Set output A to 1

This sets the PORT field of register C (C1) to 1 and then writes register C to the currently targeted board.

[1] Change output B (Out B) (not available on '220)

To access this command in the program, select a board in the “Define boards to program” screen and then press [Q]! . This will place you in the “Select from the available options” screen. Press [N], which will place you in the “Change C Register” screen. The command [1] is on this screen.

Selects the logic state of output B.

[0]! Reset output B to 0

This resets the OUTB bit of register C (C0) to 0 and then writes register C to the currently targeted board.

[1]! Set output B to 1

This sets the OUTB bit of register C (C0) to 1 and then writes register C to the currently targeted board.

[2] Change PD_{Out} current with Output A defined as port (not available on '220)

To access this command in the program, select a board in the “Define boards to program” screen and then press [Q]! . This will place you in the “Select from the available options” screen. Press [N], which will place you in the “Change C Register” screen. The command [2] is on this screen.

If A₂₃, A₂₂ are both 0 then the currently targeted board is set up as a port and the following sub-menu options are provided:

[0]! 70%

The PD_{Out} field of register C (bits C₃ and C₂) is set to 00 binary while the remaining bits of register C are preserved and the C register is written to the targeted board.

[1]! 80%

The PD_{Out} field of register C (bits C₃ and C₂) is set to 01 binary while the remaining bits of register C are preserved and the C register is written to the targeted board.

[2]! 90%

The PD_{Out} field of register C (bits C₃ and C₂) is set to 10 binary while the remaining bits of register C are preserved and the C register is written to the targeted board.

[3]! 100%

The PD_{Out} field of register C (bits C₃ and C₂) is set to 11 binary while the remaining bits of register C are preserved and the C register is written to the targeted board.

[2] Change PD_{Out} current with Output A NOT defined as port (not available on '220)

To access this command in the program, select a board in the “Define boards to program” screen and then press [Q]! . This will place you in the “Select from the available options” screen. Press [N], which will place you in the “Change C Register” screen. The command [2] is on this screen.

[0]! 25%

The PD_{Out} field of register C (bits C₃ and C₂) is set to 00 binary while the remaining bits of register C are preserved and the C register is written to the targeted board.

[1]! 50%

The PD_{Out} field of register C (bits C₃ and C₂) is set to 01 binary while the remaining bits of register C are preserved and the C register is written to the targeted board.

[2]! 75%

The PD_{Out} field of register C (bits C₃ and C₂) is set to 10 binary while the remaining bits of register C are preserved and the C register is written to the targeted board.

[3]! 100%

The PD_{Out} field of register C (bits C₃ and C₂) is set to 11 binary while the remaining bits of register C are preserved and the C register is written to the targeted board.

[2] Change PD_{Out} current (only available on '220)

To access this command in the program, select a board in the “Define boards to program” screen and then press [Q]! . This will place you in the “Select from the available options” screen. Press [N], which will place you in the “Change C Register” screen. The command [2] is on this screen.

See page 27 of this document for a sample screen shot of this command.

[0]! 5%

The PD_{Out} field of register C (bits C₅ and C₄) is set to 00 binary while the remaining bits of register C are preserved and the C register is written to the targeted board.

[1]! 50%

The PD_{Out} field of register C (bits C₅ and C₄) is set to 01 binary while the remaining bits of register C are preserved and the C register is written to the targeted board.

[2]! 80%

The PD_{Out} field of register C (bits C₅ and C₄) is set to 10 binary while the remaining bits of register C are preserved and the C register is written to the targeted board.

[3]! 100%

The PD_{Out} field of register C (bits C₅ and C₄) is set to 11 binary while the remaining bits of register C are preserved and the C register is written to the targeted board.

[3] Change phase detector select

To access this command in the program, select a board in the “Define boards to program” screen and then press [Q]! . This will place you in the “Select from the available options” screen. Press [N], which will place you in the “Change C Register” screen. The command [3] is on this screen.

See page 28 of this document for a sample screen shot of this command.

This command displays a submenu with the following options. It gives the user the ability to select which phase detector is selected.

[0]! phi R & phi V

Bit C₆ of register C is reset to 0 while the remaining bits are preserved and the C register is written to the targeted board.

[1]! PD_{Out}

Bit C₆ of register C is set to 1 while the remaining bits are preserved and the C register is written to the targeted board.

[3] Change phase detector (only available on '220)

To access this command in the program, select a board in the “Define boards to program” screen and then press [Q]! . This will place you in the “Select from the available options” screen. Press [N], which will place you in the “Change C Register” screen. The command [3] is on this screen.

This command displays a submenu with the following options. It gives the user the ability to select which phase detector is selected.

[0]! phi R & phi V

Bit C₂ of register C is set to 1 while the remaining bits are preserved and the C register is written to the targeted board.

[1]! PDout

Bit C₂ of register C is reset to 0 while the remaining bits are preserved and the C register is written to the targeted board.

[4] Change lock detect enable (not available on '220)

To access this command in the program, select a board in the “Define boards to program” screen and then press [Q]! . This will place you in the “Select from the available options” screen. Press [N], which will place you in the “Change C Register” screen. The command [4] is on this screen.

This command displays a submenu with the following options. It gives the user the ability to change the lock detect setting.

[0]! Output low

Bit C₅ of the C register is reset to 0 while the remaining bits are preserved and the C register is written to the targeted board.

[1]! Enable output

Bit C₅ of the C register is set to 1 while the remaining bits are preserved and the C register is written to the targeted board.

[5] Change phase detector polarity

To access this command in the program, select a board in the “Define boards to program” screen and then press [Q]! . This will place you in the “Select from the available options” screen. Press [N], which will place you in the “Change C Register” screen. The command [5] is on this screen.

See page 29 of this document for a sample screen shot of this command.

This command displays a submenu with the following options. It gives the user the ability to change the output polarity of the phase detector.

[0]! Non-invert PDout

Bit C₇ (C₀ for '220) of the C register is reset to 0 while the remaining bits are preserved and the C register is written to the targeted board.

[1]! Invert PDout

Bit C₇ (C₀ for '220) of the C register is set to 1 while the remaining bits are preserved and the C register is written to the targeted board.

[6] Change standby

To access this command in the program, select a board in the “Define boards to program” screen and then press [Q]! . This will place you in the “Select from the available options” screen. Press [N], which will place you in the “Change C Register” screen. The command [6] is on this screen.

See page 30 of this document for a sample screen shot of this command.

This command displays a submenu with the following commands available to set the STBY (standby) field of the C register:

[0]! Normal operation

The STBY field of register C (bit C₄) is reset to 0 while the remaining bits of register C are preserved and the C register is written to the targeted board.

[1]! Standby

The STBY field of register C (bit C₄) is set to 1 while the remaining bits of register C are preserved and the C register is written to the targeted board.

[7] Change prescale (only available on '220)

To access this command in the program, select a board in the “Define boards to program” screen and then press [Q]! . This will place you in the “Select from the available options” screen. Press [N], which will place you in the “Change C Register” screen. The command [7] is on this screen.

This command displays a submenu with the following commands available to set the prescale:

[0]! Prescale 32/33

The prescale is set to 32/33 while the remaining bits of the C register are preserved and the C register is written to the targeted board.

[1]! Prescale 64/65

The prescale is set to 64/65 while the remaining bits of the C register are preserved and the C register is written to the targeted board.

[R] Set crystal/reference mode

To access this command in the program, select a board in the “Define boards to program” screen and then press [Q]! . This will place you in the “Select from the available options” screen. The command [R] is on this screen.

See page 32 of this document for a sample screen shot of this command.

This command displays a submenu with the following commands:

[0]! Crystal mode, shutdown

Bits R₁₅, R₁₄, and R₁₃ of register R are reset to 000 binary while the remaining bits are preserved and the R register is written to the targeted board.

[1]! Crystal mode, active

Bits R₁₅, R₁₄, and R₁₃ of register R are set to 001 binary while the remaining bits are preserved and the R register is written to the targeted board.

[2]! Reference mode, REF_{in} enabled, REF_{out} low

Bits R₁₅, R₁₄, and R₁₃ of register R are set to 010 binary while the remaining bits are preserved and the R register is written to the targeted board.

[3]! Reference mode, REF_{out} = REF_{in}

Bits R₁₅, R₁₄, and R₁₃ of register R are set to 011 binary while the remaining bits are preserved and the R register is written to the targeted board.

[4]! Reference mode, REF_{out} = REF_{in}/2

Bits R₁₅, R₁₄, and R₁₃ of register R are set to 100 binary while the remaining bits are preserved and the R register is written to the targeted board.

[5]! Reference mode, REF_{out} = REF_{in}/4

Bits R₁₅, R₁₄, and R₁₃ of register R are set to 101 binary while the remaining bits are preserved and the R register is written to the targeted board.

[6]! Reference mode, REF_{out} = REF_{in}/8

Bits R₁₅, R₁₄, and R₁₃ of register R are set to 110 binary while the remaining bits are preserved and the R register is written to the targeted board.

[7]! Reference mode, REF_{out} = REF_{in}/16

Bits R₁₅, R₁₄, and R₁₃ of register R are set to 111 binary while the remaining bits are preserved and the R register is written to the targeted board.

[T]! Set target PLL on board

To access this command in the program, select a board in the “Define boards to program” screen and then press [Q]! . This will place you in the “Select from the available options” screen. The command [T]! is on this screen.

See page 21 of this document for a sample screen shot of this command.

This command is only available when the targeted board is a MC145220EVK, and that board is in single loop mode (see [B]! command). The MC145220EVK contains two PLLs, which are designated PLL and PLL'. This command is a toggle function which directs the program to “steer” subsequent commands to either PLL or PLL' on the targeted MC145220EVK.

[P] Set output port address

To access this command in the program, select a board in the “Define boards to program” screen and then press [Q]! . This will place you in the “Select from the available options” screen. The command [P] is on this screen.

See page 31 of this document for a sample screen shot of this command.

This command prompts the user to input a hexadecimal address of the printer port on their computer. This address is where the EVK boards are connected. The entered address is displayed on the main menu next to the [P] command prompt.

[G] Change board definitions

To access this command in the program, select a board in the “Define boards to program” screen and then press [Q]! . This will place you in the “Select from the available options” screen. The command [G] is on this screen.

This command returns the user to the board definition screen. The user may then define a different cascade of boards.

[I]! Initialize board(s), write all registers

To access this command in the program, select a board in the “Define boards to program” screen and then press [Q]! . This will place you in the “Select from the available options” screen. The command [I] is on this screen.

See page 21 of this document for a sample screen shot of this command.

This command writes out all of the registers for all of the boards that are currently attached to the computer. The current settings are used for the registers.

This correctly writes out the C, R, and A registers for each EVK board connected to the bus. In the case of MC145220EVKs, they are set to SINGLE (RESET/DEFAULT) mode and then have both PLL and PLL' registers written.

[X]! Terminate demonstration program

This command is available on all screens within the program.

This command causes the program to terminate and returns the user to DOS.

[?]! View help screen

This command is available on all screens within the program.

This command displays the help screen.

APPENDIX

MC145220 PLL Evaluation Board

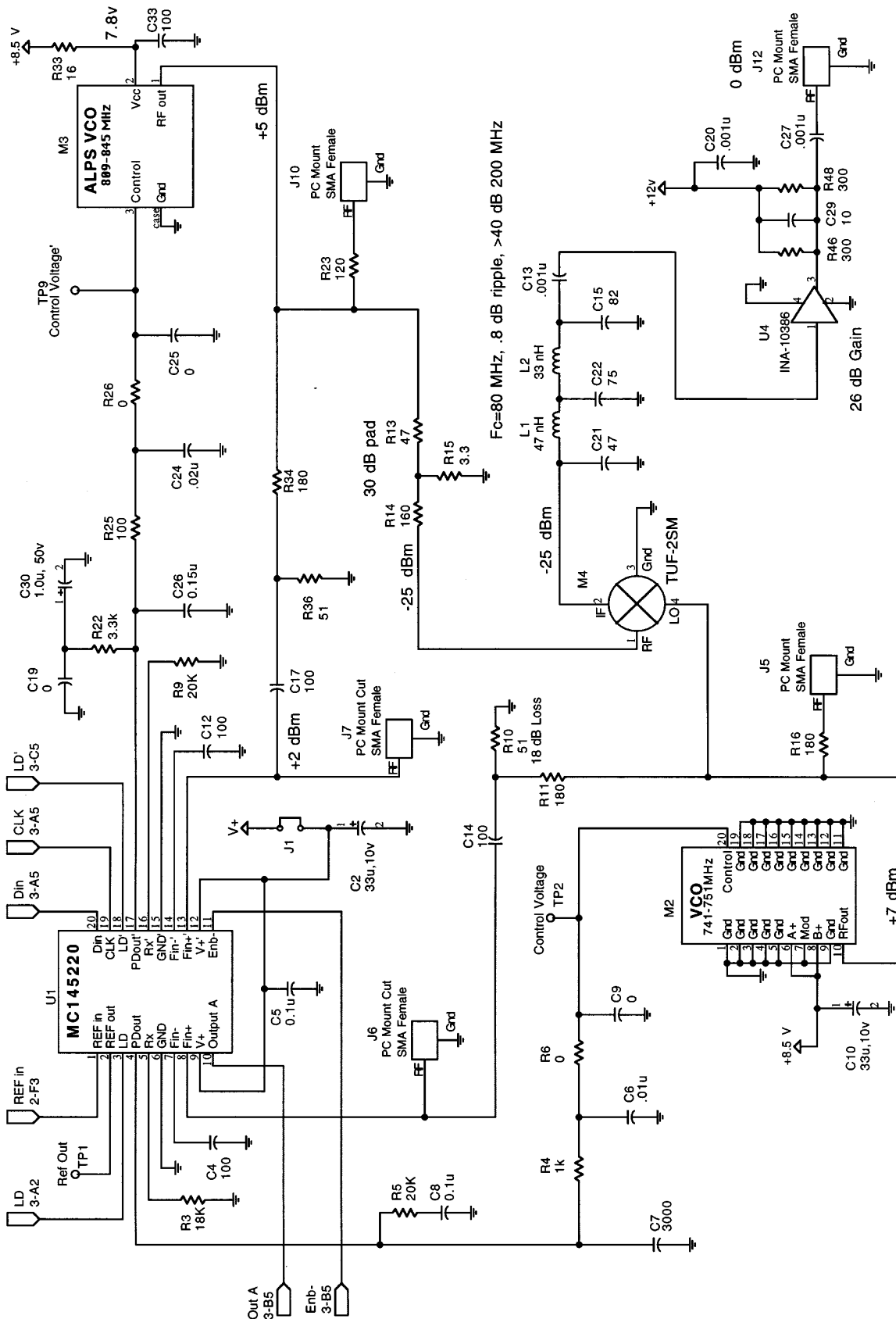

MC145220 Power Supply and Reference

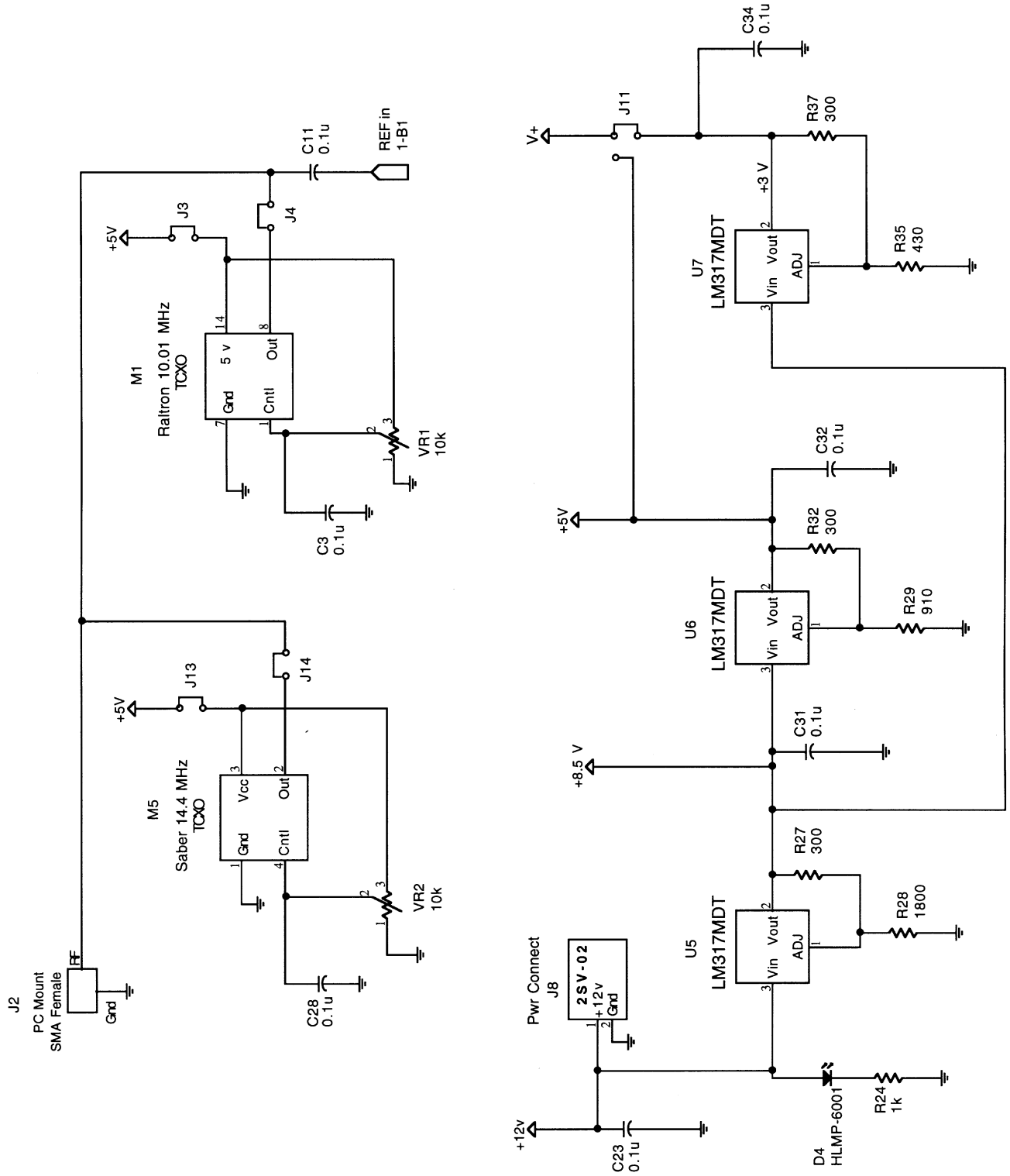

MC145220EVK Bus Interface

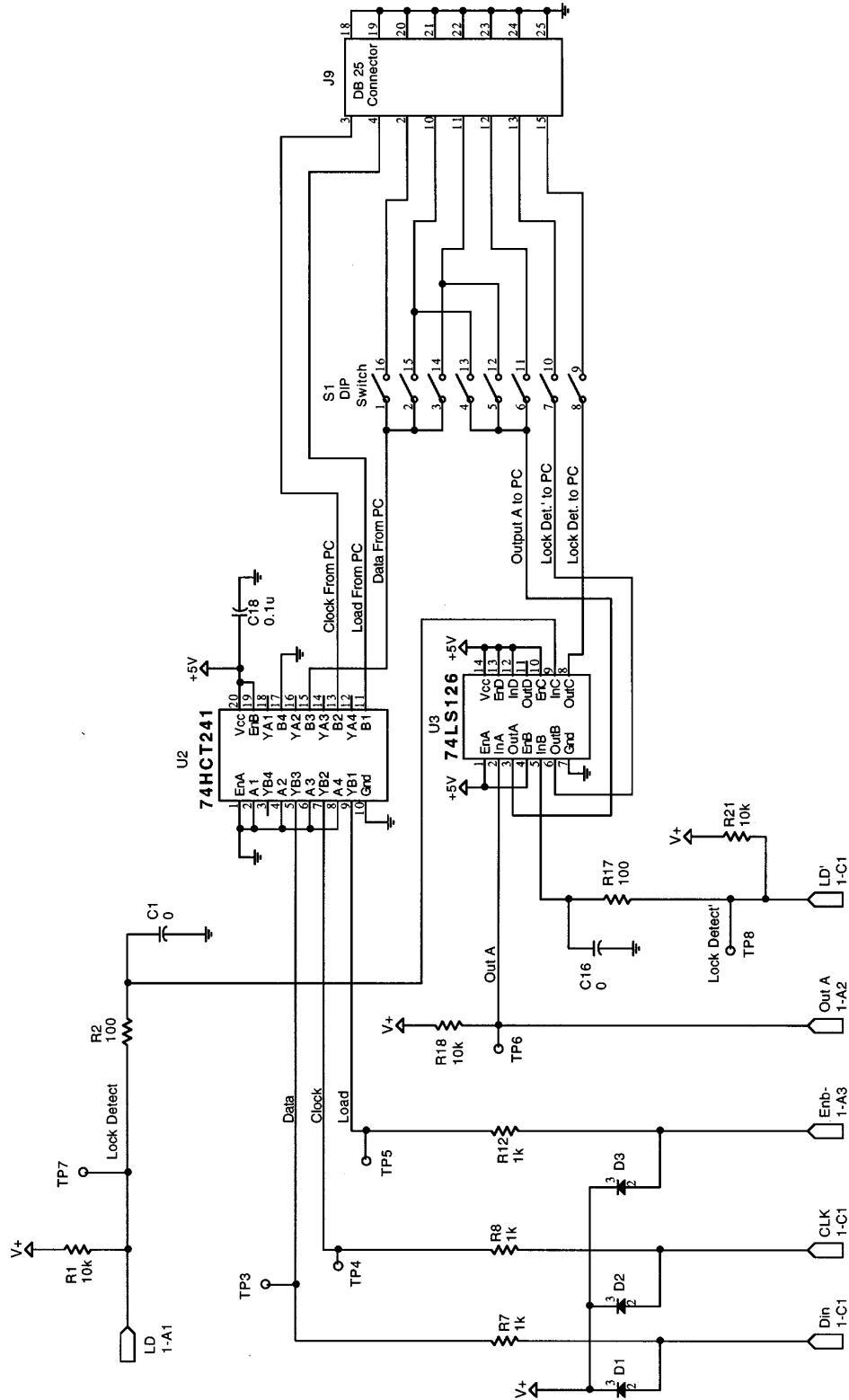

MC145220EVK Signal Plot — Dual Loop Mode Output at 70 MHz

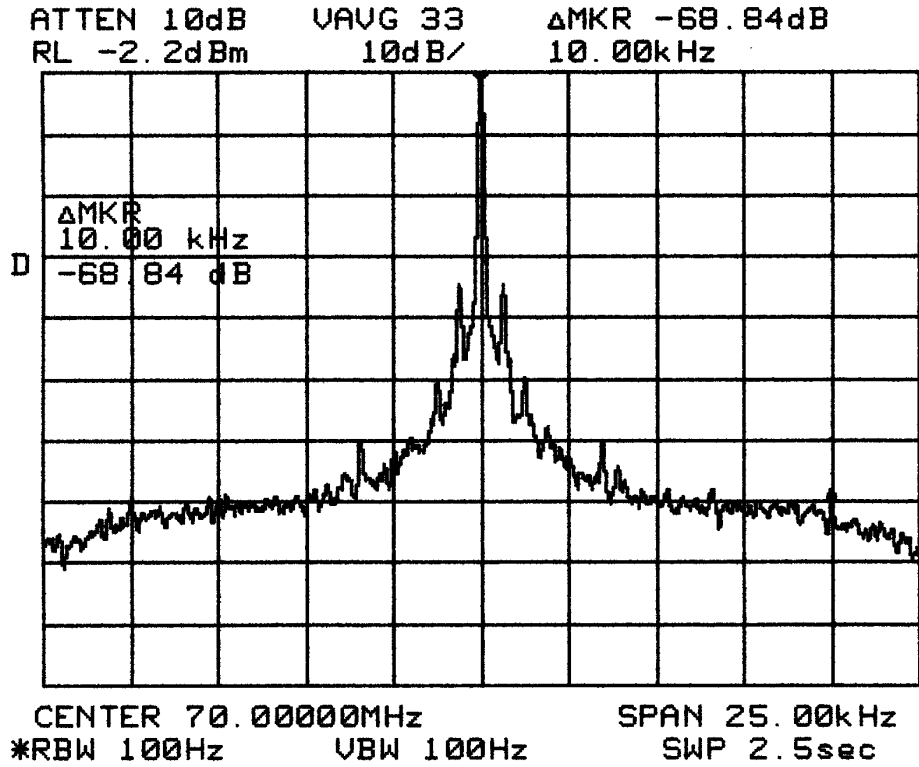

MC145220EVK Signal Plot — Single Loop Mode PLL on 805 MHz

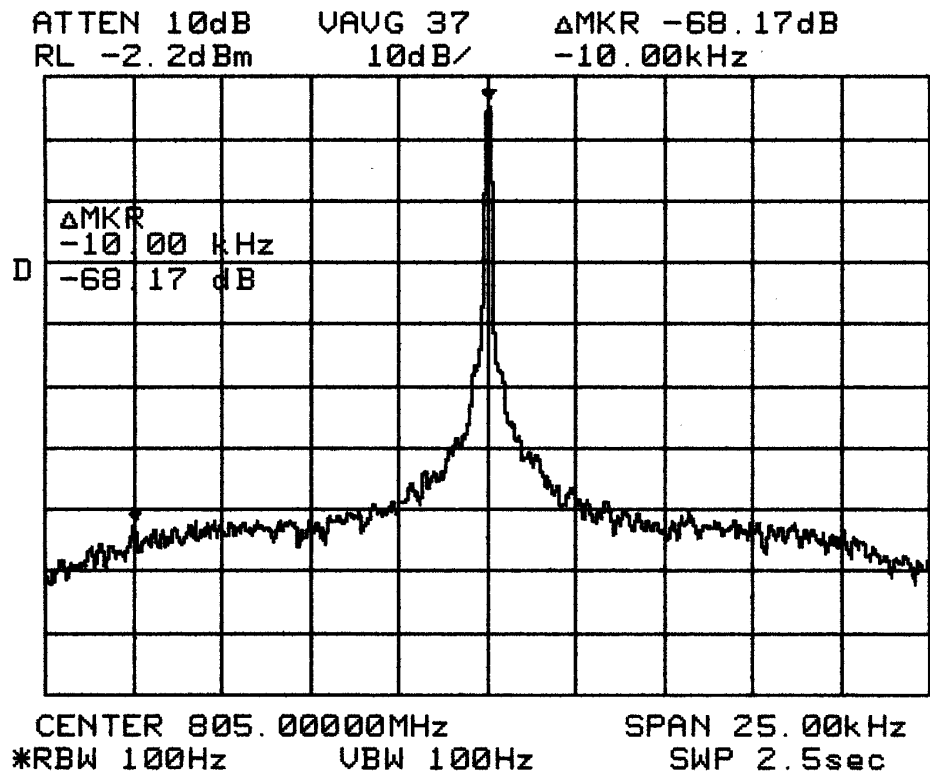

MC145220EVK Signal Plot — Single Loop Mode PLL on 738 MHz

ATTEN 10dB VAUG 21 ΔMKR -76.67dB
RL -2.2dBm 10dB/ -10.00kHz

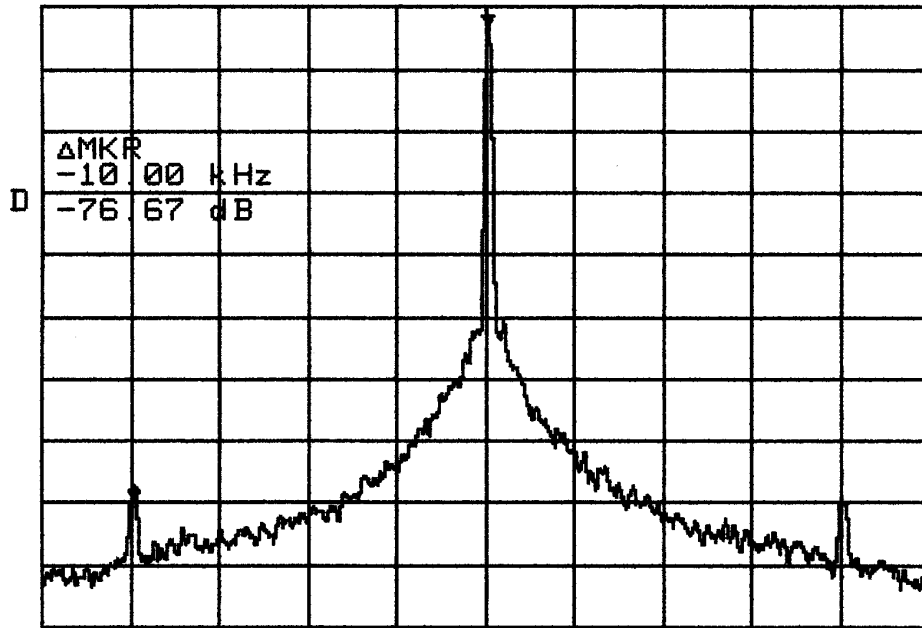

CENTER 737.99987MHz SPAN 25.00kHz
*RBW 100Hz VBW 100Hz SWP 2.5sec

Bill of Materials

MC145220 PLL Evaluation Board Rev. 4

Part	Type	Package	Manufacturer	Value	Quantity	References
2SV-02	Pwr Connect	Special	Augat		1	J8
50-651-0000-31	SMA Female	Special	ITT Sealectro		4	J2, J5, J10, J12
51R05279V17	VCO	Special	Special		1	M2
76SB08S	Logic Switch	16-Pin DIP	Grayhill		1	S1
617Y-025SAJ120	DB-25 Female	Special	Amphenol		1	J9
3266W1-103	Trim Pot.	Special	Bourns	10 k	2	VR1, VR2
Capacitor	5% NPO	0805		0.001 μ F	4	C6, C13, C20, C27
Capacitor	5% NPO	0805		0.02 μ F	1	C24
Capacitor	Ceramic	0805		0.1 μ F	10	C3, C5, C8, C11, C18, C23, C28, C31, C32, C34
Capacitor	5% NPO	0805		0.15 μ F	1	C26
Capacitor	5% NPO	0805		10	1	C29
Capacitor	5% NPO	0805		47	1	C21
Capacitor	5% NPO	0805		75	1	C22
Capacitor	5% NPO	0805		82	1	C15
Capacitor	5% NPO	0805		100	5	C4, C12, C14, C17, C33
Capacitor	5% NPO	0805		3000	1	C7
HLMP-6001-011	LED	Special	HP		1	D4
HSMS-8101	Diode	SOT-23	HP		3	D1, D2, D3
INA-10386			HP		1	U4
Inductor 1008CS		1008	Coilcraft	33 nH	1	L2
Inductor 1008CS		1008	Coilcraft	47 nH	1	L1
Jumper	2 x 1 Header	0.1" Grid			1	J1
KXN1142AA SP01	Saber TCXO	Special	Motorola	14.4 MHz	1	M5
LM317MDT	Regulator	Special	Motorola		3	U5, U6, U7
MC74HCT241ADW	Octal Buffer	SO-20	Motorola		1	U2
MC145220F	PLL IC	SOG-20	Motorola		1	U1
Resistor	5% CF	0805		0	2	R6, R26
Resistor	5% CF	0805		1 k	5	R4, R7, R8, R12, R24
Resistor	5% CF	0805		3.3	1	R15
Resistor	5% CF	0805		3.3 k	1	R22
Resistor	5% CF	0805		10 k	3	R1, R18, R21
Resistor	5% CF	0805		16	1	R33
Resistor	5% CF	0805		18 k	1	R3
Resistor	5% CF	0805		20 k	2	R5, R9
Resistor	5% CF	0805		47	1	R13
Resistor	5% CF	0805		51	2	R10, R36
Resistor	5% CF	0805		100	1	R25

Continued on next page

Continued from previous page

Resistor	5% CF	0805		120	1	R23
Resistor	5% CF	0805		160	1	R14
Resistor	5% CF	0805		180	3	R11, R16, R34
Resistor	5% CF	0805		300	5	R27, R32, R37, R46, R48
Resistor	5% CF	0805		430	1	R35
Resistor	5% CF	0805		910	1	R29
Resistor	5% CF	0805		1800	1	R28
RTVXO-231BX	TCXO	Special	Raltron	10.01 MHz	1	M1
SN74LS126D	Quad Buffer	SO-14	Motorola		1	U3
TDC-105K050NSE	Tant. Cap.	Special	Mallory	1.0 μ F, 50 V	1	C30
TDC-336K010NSF	Tant. Cap.	Special	Mallory	33 μ F, 10 V	2	C2, C10
TUF-2SM	Diode Mixer		Mini Circuits		1	M4
URAE4-417A	VCO	Special	Alps		1	M3
Wire Jumper	0.6", 24 AWG				2	J3, J4
Wire Jumper 2-Way	0.6", 24 AWG				1	J11
SJ5027SPBL	Rubber Bumpers		3M		5	

NOTES:

1. J11 connects V+ to + 5 V.
2. Test point holes should not be filled with solder.
3. The rubber bumpers must be glued on bottom side of board in the four corners and in the center.
4. Do not wash the board.

Motorola reserves the right to make changes without further notice to any products herein. Motorola makes no warranty, representation or guarantee regarding the suitability of its products for any particular purpose, nor does Motorola assume any liability arising out of the application or use of any product or circuit, and specifically disclaims any and all liability, including without limitation consequential or incidental damages. "Typical" parameters which may be provided in Motorola data sheets and/or specifications can and do vary in different applications and actual performance may vary over time. All operating parameters, including "Typicals" must be validated for each customer application by customer's technical experts. Motorola does not convey any license under its patent rights nor the rights of others. Motorola products are not designed, intended, or authorized for use as components in systems intended for surgical implant into the body, or other applications intended to support or sustain life, or for any other application in which the failure of the Motorola product could create a situation where personal injury or death may occur. Should Buyer purchase or use Motorola products for any such unintended or unauthorized application, Buyer shall indemnify and hold Motorola and its officers, employees, subsidiaries, affiliates, and distributors harmless against all claims, costs, damages, and expenses, and reasonable attorney fees arising out of, directly or indirectly, any claim of personal injury or death associated with such unintended or unauthorized use, even if such claim alleges that Motorola was negligent regarding the design or manufacture of the part. Motorola and  are registered trademarks of Motorola, Inc. Motorola, Inc. is an Equal Opportunity/Affirmative Action Employer.

How to reach us:

USA/EUROPE/Locations Not Listed: Motorola Literature Distribution;
P.O. Box 20912; Phoenix, Arizona 85036. 1-800-441-2447 or 602-303-5454

MFAX: RMFAX0@email.sps.mot.com – TOUCHTONE 602-244-6609
INTERNET: <http://Design-NET.com>

JAPAN: Nippon Motorola Ltd.; Tatsumi-SPD-JLDC, 6F Seibu-Butsuryu-Center,
3-14-2 Tatsumi Koto-Ku, Tokyo 135, Japan. 81-3-3521-8315

ASIA/PACIFIC: Motorola Semiconductors H.K. Ltd.; 8B Tai Ping Industrial Park,
51 Ting Kok Road, Tai Po, N.T., Hong Kong. 852-26629298



MC145220EVK/D

