

Product Preview

LCD Segment / Common Driver

CMOS

MC141800A is a CMOS LCD Driver which consists of 193 high voltage LCD driving signals to drive 128 Segment and 65 Common display. It has 6800-series parallel, IIC serial interface and Serial Peripheral interface (SPI) capability for operating with general MCU. Besides the general LCD driver features, it has on chip LCD Smart Bias Divider circuit such that minimize external component required in applications.

MC141800AT: TAB (Tape Automated Bonding)

MCC141800AZ: Gold Bump Die

- Single Supply Operation, 2.4 V - 3.5 V
- Maximum 16.5V LCD Driving Output Voltage
- Low Current Stand-by Mode (<1uA)
- On Chip Internal DC/DC Converter / External Power Supply
- Smart Bias Divider
- 4X / 5X DC-DC Converter
- 8 bit 6800-series Parallel Interface, 1 MHz IIC Serial Interface and Serial Peripheral Interface (SPI)
- On chip Oscillator
- Graphic Mode Operation
- On Chip 128 x 65 Display Data RAM
- Master Clear RAM
- Low Power Icon Mode (128 icons, <25uA)
- Display Masks for Implementation of Blinking Effect
- 1 to 65 Selectable Multiplex Ratio
- 1:7 / 1:9 Bias Ratio
- Re-mapping of Row and Column Drivers
- 16 level Internal Contrast Control
- External Contrast Control
- Built-in Temperature Compensation Circuit
- Selectable Display Waveform: Type B or Type C Waveform
- 2V Icon Mode Display On

MC141800A

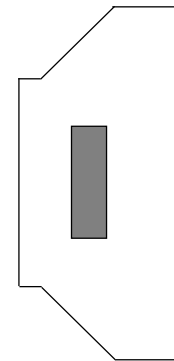

MC141800AT
TAB



MCC141800AZ
Gold bump die

ORDERING INFORMATION

MC141800AT	70 mm TAB
MCC141800AZ	Gold Bump Die

This document contains information on a product under development. Motorola reserves the right to change or discontinue this product without notice.

REV O
2/97

Block Diagram

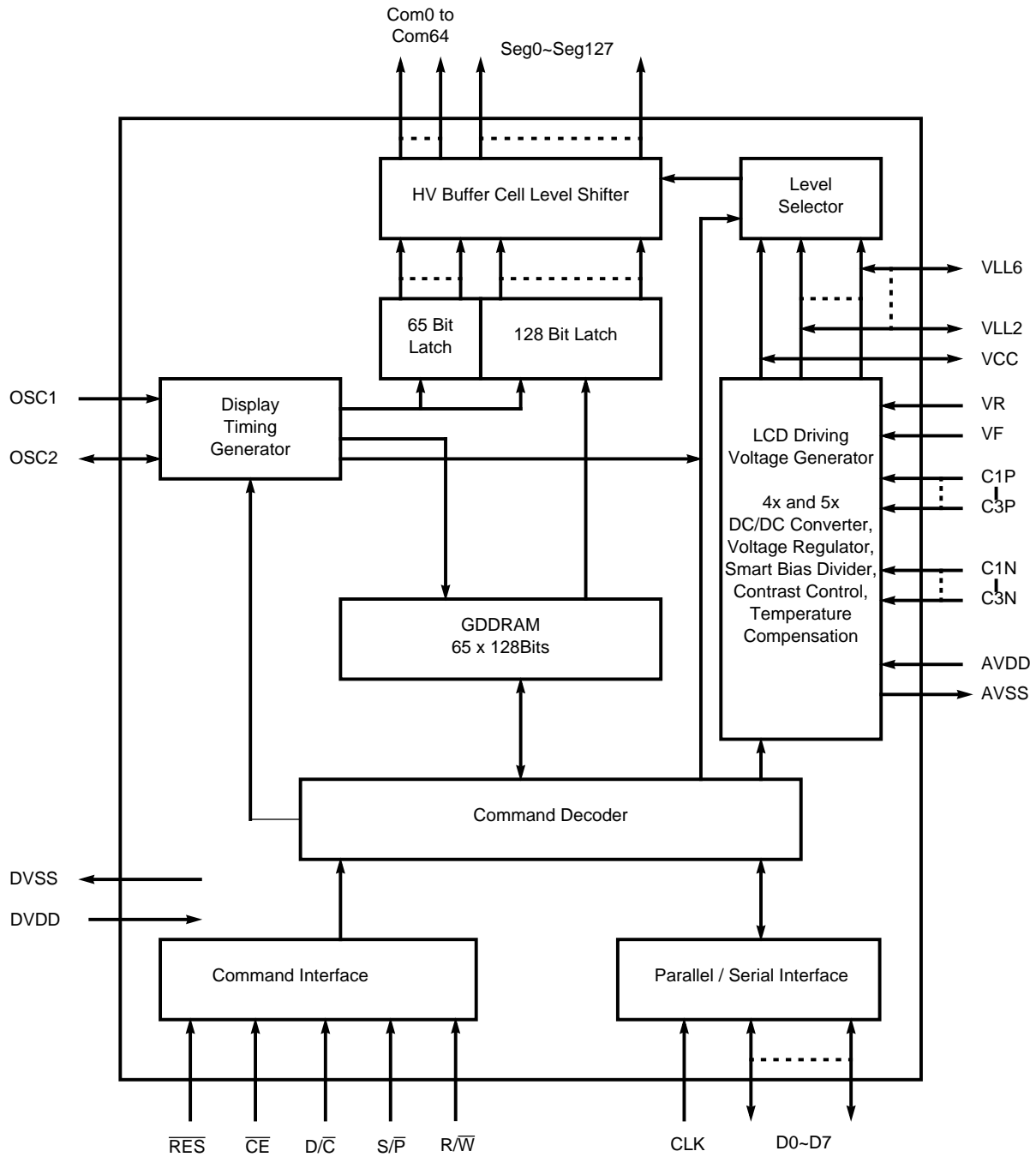

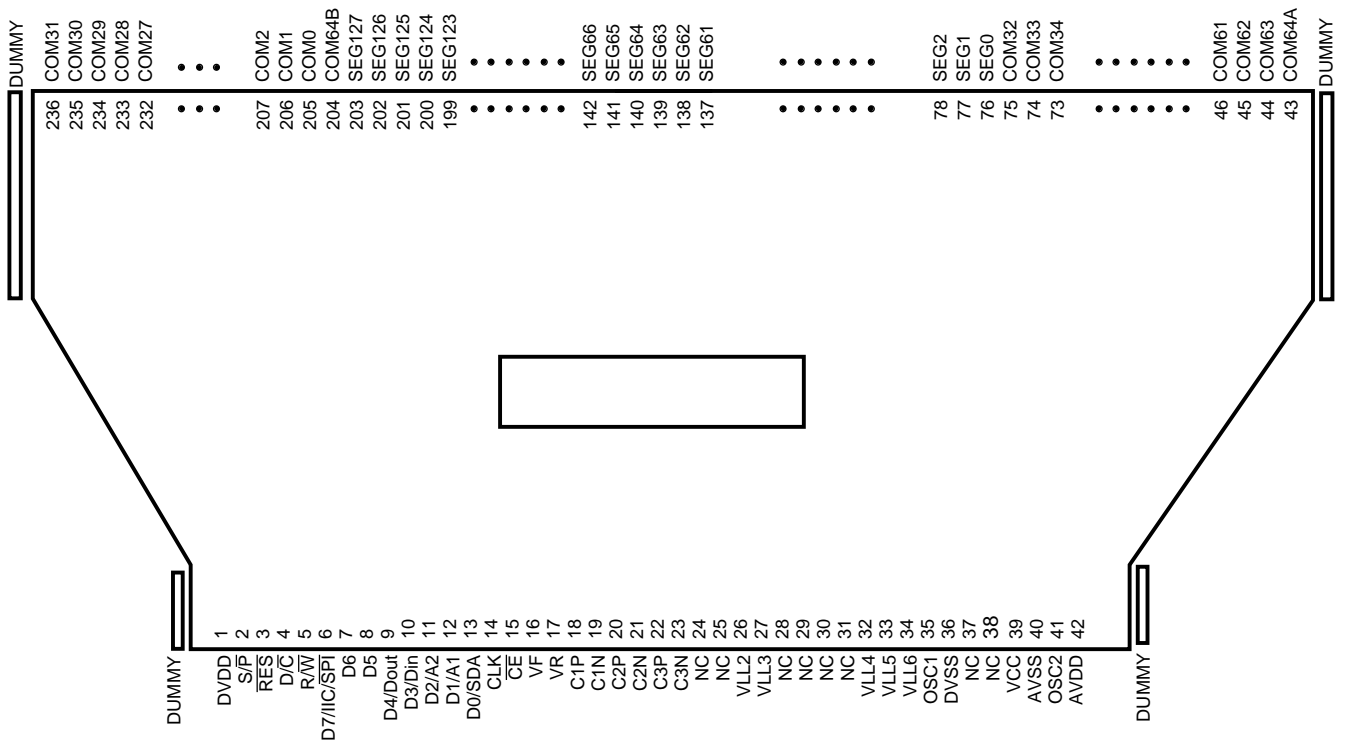

**MC141800AT PIN ASSIGNMENT
(COPPER VIEW)**

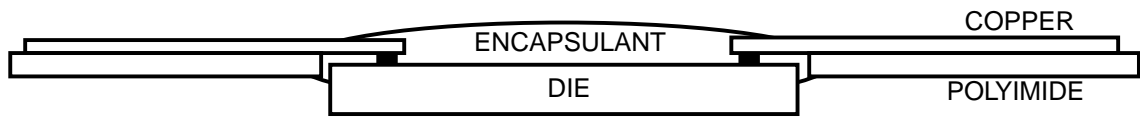

Mirror Design TAB

Die Pad Layout for MC141800A

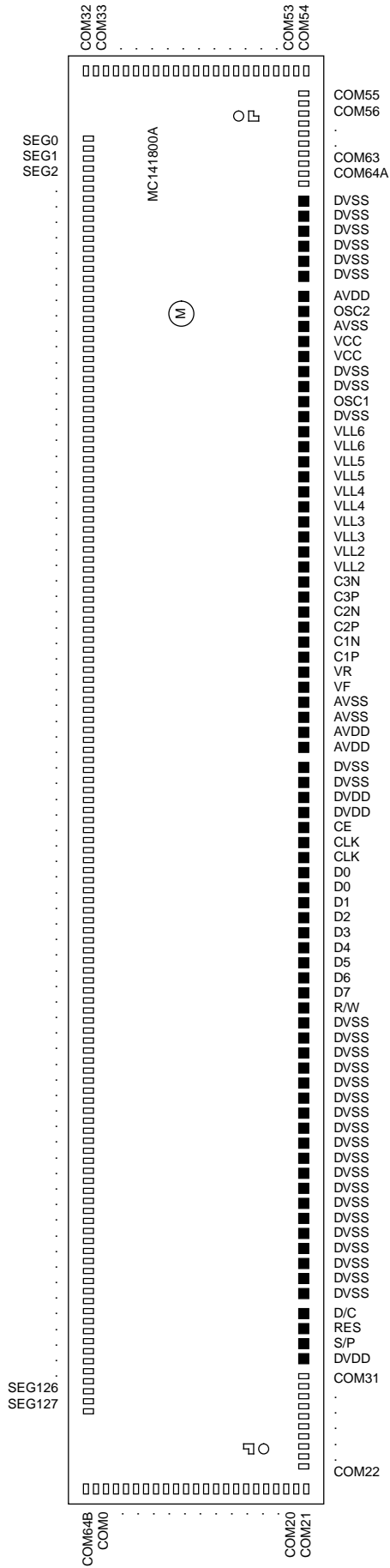

- Gold Bump Size :
- Input Pad, 65 x 65 (um)
 - Output Pad, 42 x 100 (um)

MAXIMUM RATINGS* (Voltages Referenced to V_{SS} , $T_A=25^\circ\text{C}$)

Symbol	Parameter	Value	Unit
AV_{DD}, DV_{DD}	Supply Voltage	-0.3 to +4.0	V
V_{CC}		$V_{SS}-0.3$ to $V_{SS}+16.5$	V
V_{in}	Input Voltage	$V_{SS}-0.3$ to $V_{DD}+0.3$	V
I	Current Drain Per Pin Excluding V_{DD} and V_{SS}	25	mA
T_A	Operating Temperature	-30 to +85	$^\circ\text{C}$
T_{stg}	Storage Temperature Range	-65 to +150	$^\circ\text{C}$

* Maximum Ratings are those values beyond which damage to the device may occur. Functional operation should be restricted to the limits in the Electrical Characteristics tables or Pin Description section.

$V_{SS} = AV_{SS} = DV_{SS}$ ($DV_{SS} = V_{SS}$ of Digital circuit, $AV_{SS} = V_{SS}$ of Analogue Circuit)

$V_{DD} = AV_{DD} = DV_{DD}$ ($DV_{DD} = V_{DD}$ of Digital circuit, $AV_{DD} = V_{DD}$ of Analogue Circuit)

This device contains circuitry to protect the inputs against damage due to high static voltages or electric fields; however, it is advised that normal precautions to be taken to avoid application of any voltage higher than maximum rated voltages to this high impedance circuit. For proper operation it is recommended that V_{in} and V_{out} be constrained to the range $V_{SS} < \text{or} = (V_{in} \text{ or } V_{out}) < \text{or} = V_{DD}$. Reliability of operation is enhanced if unused input are connected to an appropriate logic voltage level (e.g., either V_{SS} or V_{DD}). Unused outputs must be left open. This device may be light sensitive. Caution should be taken to avoid exposure of this device to any light source during normal operation. This device is not radiation protected.

ELECTRICAL CHARACTERISTICS (Voltage Referenced to V_{SS} , $V_{DD}=2.4$ to 3.5V , $T_A=25^\circ\text{C}$)

Symbol	Parameter	Test Condition	Min	Typ	Max	Unit
DV_{DD} AV_{DD}	Logic Circuit Supply Voltage Range Voltage Generator Circuit Supply Voltage Range	(Absolute value referenced to V_{SS})	2.4 2.4	3.0 -	3.5 3.5	V V
I_{AC}	Access Mode Supply Current Drain ($AV_{DD} + DV_{DD}$ Pins)	$V_{DD}=3.0\text{V}$, Internal DC/DC Converter On, 5X DC/DC Converter Enabled, R/\bar{W} accessing, $T_{cyc}=1\text{MHz}$, Osc. Freq.=50KHz, Display On.	-	500	TBD	μA
I_{DP}	Display Mode Supply Current Drain ($AV_{DD} + DV_{DD}$ Pins)	$V_{DD}=3.0\text{V}$, Internal DC/DC Converter On, 5X Converter Enabled, R/W Halt, Osc. Freq.=50KHz, Display On.	-	300	TBD	μA
I_{SB}	Standby Mode Supply Current Drain ($AV_{DD} + DV_{DD}$ Pins)	$V_{DD}=3.0\text{V}$, Display off, Oscillator Disabled, R/\bar{W} halt.	-	TBD	1	μA
I_{ICON}	Icon Mode Supply Current Drain ($AV_{DD} + DV_{DD}$ Pins)	$V_{DD}=3.0\text{V}$, Internal Oscillator, Oscillator Enabled, Display On, Icon On, R/\bar{W} halt, Freq.=50KHz.	-	TBD	25	μA
V_{CC}	LCD Driving Internal DC/DC Converter Output (V_{CC} Pin)	Display On, DC/DC Converter Enabled, Osc. Freq.=50KHz, Internal Regulator Enabled, Divider Enabled.	7	15	16.5	V
V_{LCD}	LCD Driving Voltage Input (V_{CC} Pin)	Internal DC/DC Converter Disabled.	7	15	16.5	V
V_{ICON}	Low Power Icon mode Voltage		-	2	-	V
V_{OH1}	Output High Voltage (D0-D7, OSC2)	$I_{out}=100\mu\text{A}$	$0.9 \cdot V_{DD}$	-	V_{DD}	V
V_{OL1}	Output Low Voltage (D0-D7, OSC2)	$I_{out}=100\mu\text{A}$	0	-	$0.1 \cdot V_{DD}$	V
V_{R1}	LCD Driving Voltage Source (V_R Pin)	Internal Regulator Enabled (V_R voltage depends on Int/Ext Contrast Control)	0	-	$V_{CC}-0.5$	V
V_{R2}	LCD Driving Voltage Source (V_R Pin)	Internal Regulator Disable.	-	Floating	-	V

ELECTRICAL CHARACTERISTICS (Voltage Referenced to V_{SS} , $V_{DD}=2.4$ to $3.5V$, $T_A=25^\circ C$)

Symbol	Parameter	Test Condition	Min	Typ	Max	Unit
V_{IH1}	Input high voltage (RES, OSC2, CLK, \overline{CE} , D0-D7, R/ \overline{W} , D/ \overline{C} , S/ \overline{P} , OSC1)		$0.8 \cdot V_{DD}$	-	V_{DD}	V
V_{IL1}	Input Low voltage (RES, OSC2, CLK, \overline{CE} , D0-D7, R/ \overline{W} , D/ \overline{C} , S/ \overline{P} , OSC1)		0	-	$0.2 \cdot V_{DD}$	V
V_{LL6} V_{LL5} V_{LL4} V_{LL3} V_{LL2}	LCD Display Voltage Output (V_{LL6} , V_{LL5} , V_{LL4} , V_{LL3} , V_{LL2} Pins)	Smart Bias Divider Enabled, 1:9 bias ratio	-	V_R	-	V
			-	$8/9 \cdot V_R$	-	V
			-	$7/9 \cdot V_R$	-	V
			-	$2/9 \cdot V_R$	-	V
			-	$1/9 \cdot V_R$	-	V
V_{LL6} V_{LL5} V_{LL4} V_{LL3} V_{LL2}	LCD Display Voltage Output (V_{LL6} , V_{LL5} , V_{LL4} , V_{LL3} , V_{LL2} Pins)	Smart Bias Divider Enabled, 1:7 bias ratio	-	V_R	-	V
			-	$6/7 \cdot V_R$	-	V
			-	$5/7 \cdot V_R$	-	V
			-	$2/7 \cdot V_R$	-	V
			-	$1/7 \cdot V_R$	-	V
V_{LL6} V_{LL5} V_{LL4} V_{LL3} V_{LL2}	LCD Display Voltage Input (V_{LL6} , V_{LL5} , V_{LL4} , V_{LL3} , V_{LL2} Pins)	External Voltage Generator, Smart Bias Divider Dis- able	7 0 0 0 0	- - - - -	V_{CC} V_{LL6} V_{LL5} V_{LL4} V_{LL3}	V V V V V
I_{OH}	Output High Current Source (D0-D7, OSC2)	$V_{out}=V_{DD}-0.4V$	50	-	-	μA
I_{OL}	Output Low Current Drain (D0-D7, OSC2)	$V_{out}=0.4V$	-	-	-50	μA
I_{OZ}	Output Tri-state Current Drain Source (D0-D7, OSC2)		-1	-	1	μA
I_{IL}/I_{IH}	Input Current (RES, OSC2, CLK, D0-D7, R/ \overline{W} , D/ \overline{C} , S/ \overline{P} , OSC1)		-1	-	1	μA
C_{IN}	Input Capacitance (OSC1, OSC2, all logic pins)		-	5	7.5	pF
V_{CN}	Internal Contrast Control (V_R Output Voltage)	Internal Regulator Enabled, Internal Contrast control Enabled. (16 Voltage Levels Controlled by Software. Each level is typically 1.5% of the Internal Regulator Output Voltage.)	-	± 12	-	%
PTC0	Temperature Coefficient Compensation Flat Temperature Coefficient	(TC1=0, TC2=0, Internal Regulator Disabled.)	-	0.0	-	%
PTC1	Temperature Coefficient 1*	(TC1=0, TC2=1, Internal Regulator Enabled.)	-	-0.18	-	%
PTC2	Temperature Coefficient 2*	(TC1=1, TC2=0, Internal Regulator Enabled.)	-	-0.22	-	%
PTC3	Temperature Coefficient 3*	(TC1=1, TC2=1, Internal Regulator Enabled.)	-	-0.35	-	%

* The formula for the temperature coefficient is:

$$TC(\%) = \frac{VR \text{ at } 50^\circ C - VR \text{ at } 0^\circ C}{50^\circ C - 0^\circ C} \times \frac{1}{VR \text{ at } 25^\circ C} \times 100\%$$

AC ELECTRICAL CHARACTERISTICS ($T_A=25^\circ\text{C}$, Voltage referenced to V_{SS} , $AV_{DD}=DV_{DD}=3\text{V}$)

Symbol	Parameter	Test Condition	Min	Typ	Max	Unit
F_{OSC}	Oscillation Frequency of Display timing generator	60Hz Frame Frequency Either External Clock Input or Internal Oscillator Enabled	45	60	55	KHz
F_{FRM}	Frame Frequency	Graphic Display Mode, Normal Frequency Mode, 65 - 49 MUX	-	$\frac{F_{OSC}}{15 * MUX}$	-	Hz
		Graphic Display Mode, Half Frequency Mode, 65 - 49 MUX	-	$\frac{F_{OSC}}{30 * MUX}$	-	Hz
		Graphic Display Mode, Normal Frequency Mode, 48 - 33 MUX	-	$\frac{F_{OSC}}{23 * MUX}$	-	Hz
		Graphic Display Mode, Half Frequency Mode, 48 - 33 MUX	-	$\frac{F_{OSC}}{46 * MUX}$	-	Hz
		Graphic Display Mode, Normal Frequency Mode, 32 - 2 MUX	-	$\frac{F_{OSC}}{30 * MUX}$	-	Hz
		Graphic Display Mode, Half Frequency Mode, 32 - 2 MUX	-	$\frac{F_{OSC}}{60 * MUX}$	-	Hz
		6-Phase Low Power Icon Mode, Normal Frequency Mode	-	$\frac{F_{OSC}}{960}$	-	Hz
		6-Phase Low Power Icon Mode, Half Frequency Mode	-	$\frac{F_{OSC}}{1920}$	-	Hz
		4-Phase Low Power Icon Mode, Normal Frequency Mode	-	$\frac{F_{OSC}}{1024}$	-	Hz
4-Phase Low Power Icon Mode, Half Frequency Mode	-	$\frac{F_{OSC}}{2048}$	-	Hz		
OSC	Internal Oscillation Frequency with different value of feedback resistor	Internal Oscillator Enabled, V_{DD} within operation range	See Figure 1 for the relationship			

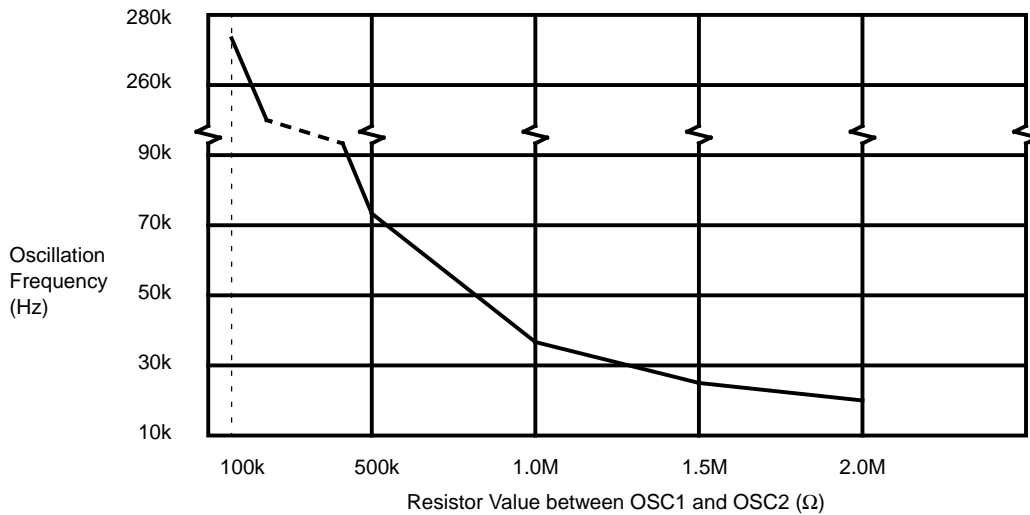

Figure 1. Internal Oscillator Frequency Relationship with External Resistor Value

TABLE 3. Parallel Timing Characteristics ($T_A=-30$ to 85°C , $DV_{DD}=2.4$ to 3.5V , $V_{SS}=0\text{V}$)

Symbol	Parameter	Min	Typ	Max	Unit
t_{cycle}	Clock Cycle Time	1000	-	-	ns
t_{AS}	Address Setup Time	90	-	-	ns
t_{AH}	Address Hold Time	60	-	-	ns
t_{DSW}	Write Data Setup Time	210	-	-	ns
t_{DHW}	Write Data Hold Time	75	-	-	ns
t_{DSR}	Read Data Setup Time	250	-	-	ns
t_{DHR}	Read Data Hold Time	75	-	-	ns
t_{ACC}	Access Time	-	-	250	ns
PW_{EL}	Enable Low Pulse Width	390	-	-	ns
PW_{EH}	Enable High Pulse Width	390	-	-	ns
t_{R}	Rise Time	-	-	45	ns
t_{F}	Fall Time	-	-	45	ns

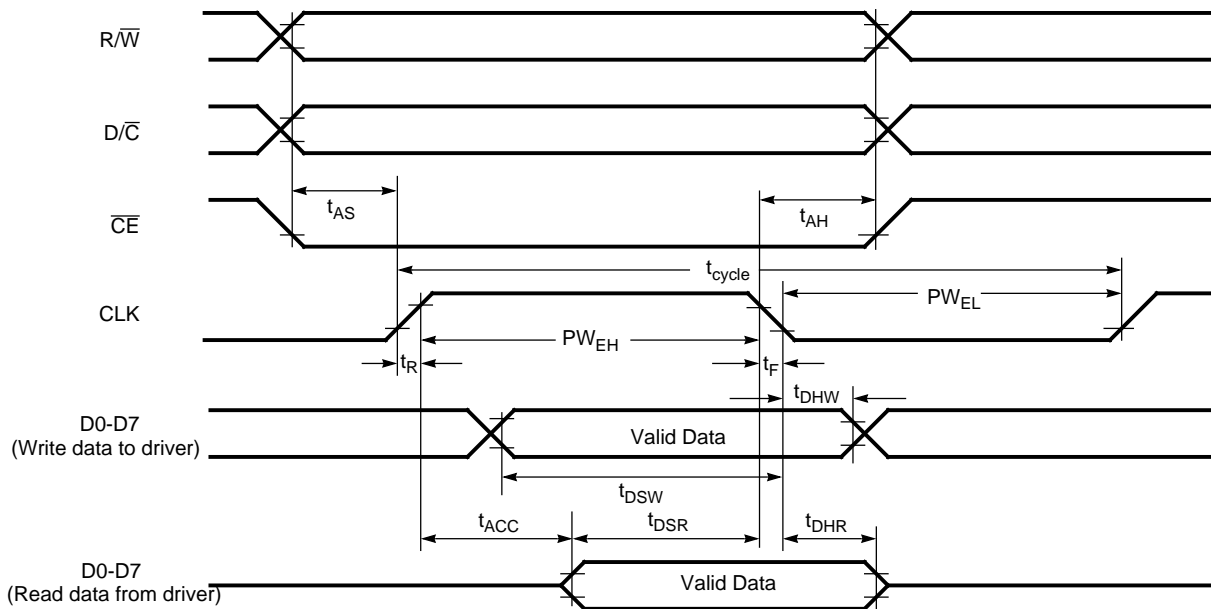

Figure 2. Parallel 6800-series Interface Timing Characteristics

TABLE 4. IIC Serial Timing Characteristics ($T_A=-30$ to 85°C , $DV_{DD}=2.4$ to 3.5V , $V_{SS}=0\text{V}$)

Symbol	Parameter	100kHz			400kHz			1MHz			Unit
		Min	Typ	Max	Min	Typ	Max	Min	Typ	Max	
t_{cycle}	Clock Cycle Time	10	-	-	2.5	-	-	1	-	-	μs
t_{HSTART}	Start condition Hold Time	4.0	-	-	0.6	-	-	0.3	-	-	μs
t_{HD}	Data Hold Time	500	-	-	300	-	-	150	-	-	ns
t_{SD}	Data Setup Time	250	-	-	100	-	-	50	-	-	ns
t_{SSTART}	Start condition Setup Time (Only relevant for a repeated Start condition)	4.7	-	-	0.6	-	-	0.3	-	-	μs
t_{SSTOP}	Stop condition Setup Time	4.0	-	-	0.6	-	-	0.3	-	-	μs
t_{R}	Rise Time for data and clock pin	-	-	1000	-	-	300	-	-	150	ns
t_{F}	Fall Time for data and clock pin	-	-	300	-	-	300	-	-	150	ns
t_{IDLE}	Idle Time before a new transmission can start	4.7	-	-	1.3	-	-	0.6	-	-	μs

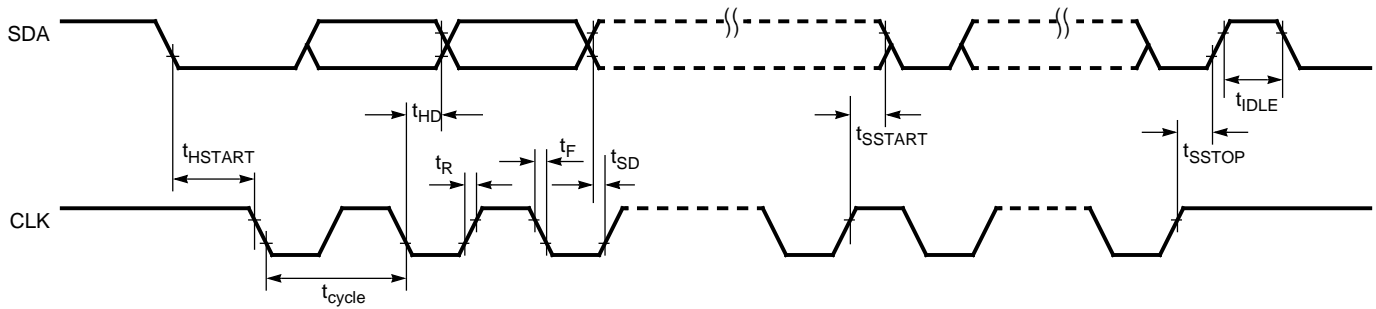

Figure 3. IIC Serial Interface Timing Characteristics

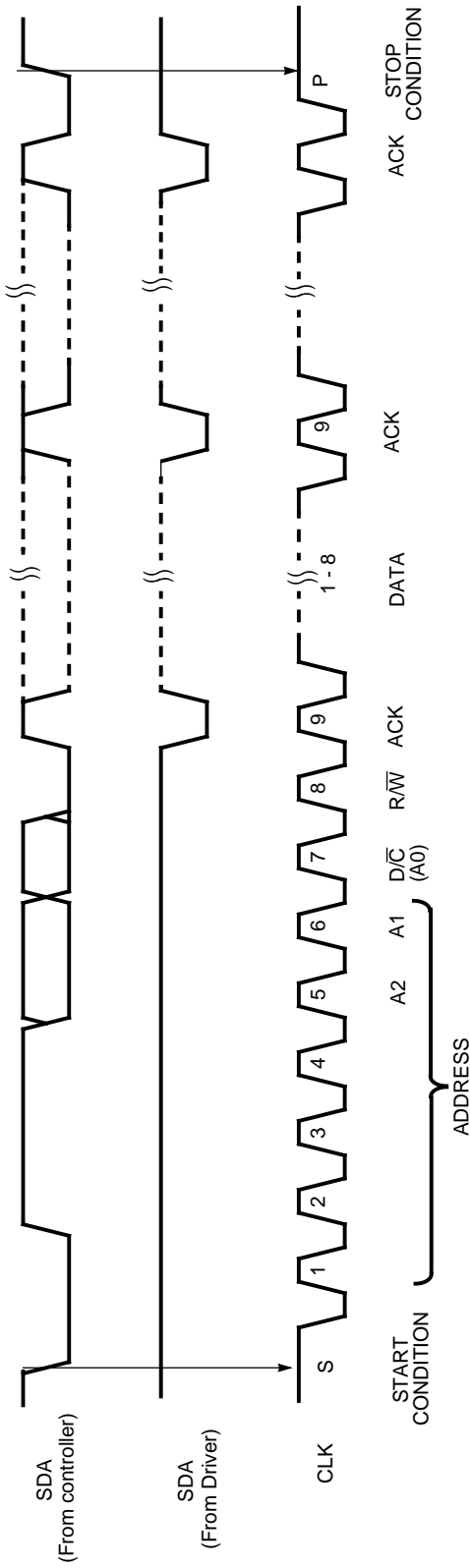

Figure 4. IIC Serial Interface Input Protocol (Write Data to Driver)

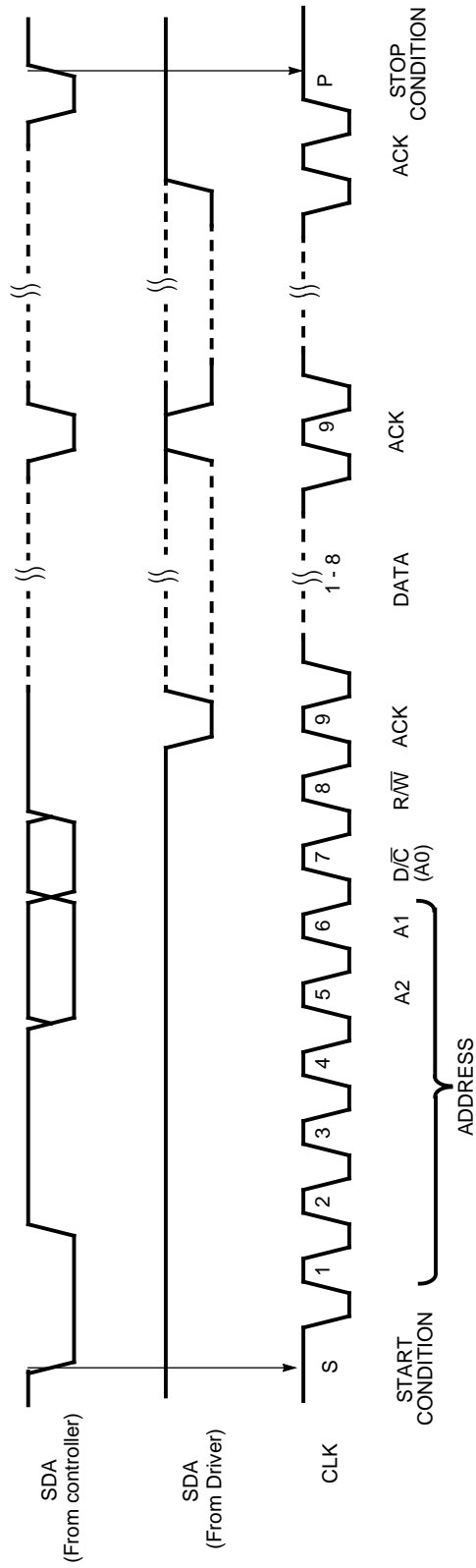

Figure 5. IIC Serial Interface Output Protocol (Read Data from Driver)

TABLE 5. SPI Timing Characteristics ($T_A=-30$ to 85°C , $DV_{DD}=2.4$ to 3.5V , $V_{SS}=0\text{V}$)

Symbol	Parameter	Min	Typ	Max	Unit
t_{cycle}	Clock Cycle Time	1000	-	-	ns
t_{LEAD}	Enable Lead Time	500	-	-	ns
t_{LAG}	Enable Lag Time	500	-	-	ns
t_{DSW}	Write Data Setup Time	100	-	-	ns
t_{DHW}	Write Data Hold Time	100	-	-	ns
t_{DVR}	Read Data Valid Time	-	-	240	ns
t_{DHR}	Read Data Hold Time	10	-	-	ns
t_{ACC}	Access Time	-	-	120	ns
t_{DIS}	Disable Time	-	-	240	ns
t_{CLKL}	Clock Low Time	380	-	-	ns
t_{CLKH}	Clock High Time	380	-	-	ns
t_{R}	Rise Time	-	-	100	ns
t_{F}	Fall Time	-	-	100	ns

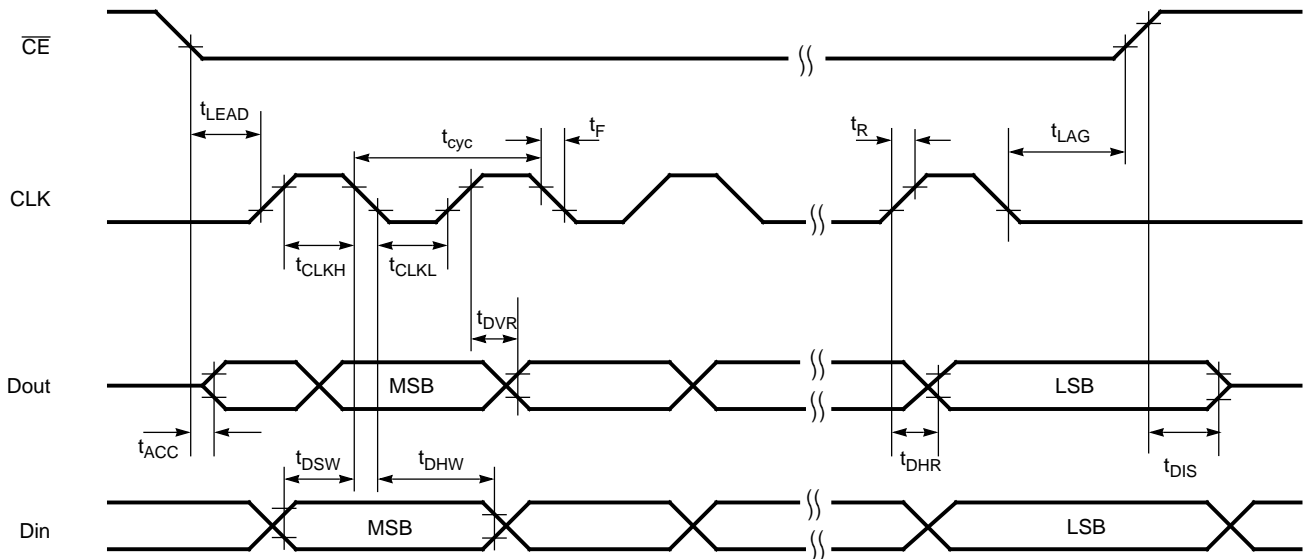

Figure 6. SPI Timing Characteristics

PIN DESCRIPTIONS

S/P (Serial / Parallel Interface)

This pin is an input pin. The pin is sampled out when reset to determine what type of interface is desired. The S/P pin input HIGH for serial interface while input LOW for parallel interface.

D/C (Data / Command)

If parallel interface is selected, this input pin acknowledges the LCD driver the input at D0-D7 is data or command. Input High for data while input Low for command. If serial interface is selected, float this pin.

CLK (Input Clock)

This pin is normal Low clock input. If parallel interface is selected, data on D0-D7 are latched at the falling edge of CLK. If IIC serial interface is selected, data on SDA is latched at the falling edge of CLK. If SPI is selected, data on Din and Dout are latched at the falling edge of CLK.

RES (Reset)

A Low input pulse to this pin resets the internal status of the driver (same as power on reset). The minimum pulse width is 10 μ s.

CE (Chip Enable)

If parallel interface is selected, this input pin is used for chip enable. If IIC serial interface is selected, leave this pin float and it will be internally tied to VDD.

D0 - D7 (Data)

This bi-directional bus is used for data / command transferring. If parallel interface is selected, D0 - D7 are connected directly to MCU for data transfer. When serial interface is selected, D7 (IIC/SPI) is an input pin to determine which type of serial interface is desired. The IIC/SPI pin HIGH indicates IIC interface is used. The IIC/SPI pin LOW indicates SPI is used.

When IIC serial interface is selected, D0 (SDA) is connected directly to MCU for data transfer, D1 (A1) and D2 (A2) are used to define the 2 bit programmable address. The address of this device is 0111xyab where x, y, a, b represent A2, A1, D/C and R/W respectively.

When SPI is selected, D3 (Din) is used to write data / command from MCU to driver and D4 (Dout) is used to read data / command to MCU from driver.

R/W (Read / Write)

If parallel interface is selected, this is an input pin. To read the display data RAM or the internal status (Busy / Idle), pull this pin High. The R/W input Low indicates a write operation to the display data RAM or to the internal setup registers. If serial interface is selected, let this pin float.

OSC1 (Oscillator Input)

For internal oscillator mode, this is an input for the internal low power RC oscillator circuit. In this mode, an external resistor of certain value should be connected between the OSC1 and OSC2 pins for a range of internal operating frequencies (refer to Figure 1). For external oscillator mode, OSC1 should be left open.

OSC2 (Oscillator Output / External Oscillator Input)

For internal oscillator mode, this is an output for the internal low power RC oscillator circuit. For external oscillator mode, OSC2 will be an input pin for external clock and no external resistor is needed.

VLL6 - VLL2

Group of voltage level pins for driving the LCD panel. They can either be connected to external driving circuit for external bias supply or connected internally to built-in divider circuit if internal divider is enable.

C1N and C1P, C2N and C2P, C3N and C3P

If Internal DC/DC Converter is enabled, a 0.1 μ F capacitor is required to connect these three pair of pins.

V_R and V_F

This is a feedback path for the gain control (external contrast control) of VLL1 to VLL6. For adjusting the LCD driving voltage, it requires a feedback resistor placed between V_R and V_F, a gain control resistor placed between V_F and AVSS, a 10 μ F capacitor placed between V_R and AVSS. (Refer to the Application Circuit)

COM0-COM63, COM64A and COM64B (Row Drivers)

These pins provide the row driving signal to LCD panel. Output is 0V during display off. COM64A and COM64B are icon lines with same signal output so as to provide the flexibility to have the icon line on top or bottom of panel, or both top and bottom of the panel. COM64A/B also serves as the common driving signal in the icon mode.

COM64A/B is special design icon line (128 icons). There are some special commands to program it separately (e.g. Set Icon Mask, Smart Icon Mode, Low Power Icon Mode)

SEG0-SEG127 (Column Drivers)

These 128 pins provide LCD column driving signal to LCD panel. They output 0V during display off.

AVDD and AVSS

AVDD is the positive supply to the LCD bias Internal DC/DC Converter. AVSS is ground.

VCC

For using the Internal DC/DC Converter, a 0.1 μ F capacitor from this pin to AVSS is required. It can also be an external bias input pin if Internal DC/DC Converter is not used. Power is supplied to the LCD Driving Level Selector and HV Buffer Cell with this pin. Normally, this pin is not intended to be a power supply to other component.

DVDD and DVSS

Power is supplied to the digital control circuit of the driver using these two pins. DVDD is power and DVSS is ground.

OPERATION OF LIQUID CRYSTAL DISPLAY DRIVER

Description of Block Diagram Module

Command Decoder and Command Interface

This module determines whether the input data is interpreted as data or command. Data is directed to this module based upon the input of the D/\bar{C} pin. If D/\bar{C} high, data is written to Graphic Display Data RAM (GDDRAM). D/\bar{C} low indicates that the input at D0-D7 is interpreted as a Command.

Reset is of same function as Power ON Reset (POR). Once \overline{RES} received the reset pulse, all internal circuitry will back to its initial status. Refer to Command Description section for more information.

MPU Parallel 6800-series Interface

The parallel interface consists of 8 bi-directional data pins (D0-D7), R/\bar{W} , D/\bar{C} , \bar{CE} and the CLK. The R/\bar{W} input High indicates a read operation from the Graphic Display Data RAM (GDDRAM). R/\bar{W} input Low indicates a write operation to Display Data RAM or Internal Command Registers depending on the status of D/\bar{C} input. The CLK input serves as data latch signal (clock). Refer to AC operation conditions and characteristics section for Parallel Interface Timing Description.

MPU Serial IIC Interface

The IIC interface consists of two communication bus: data pin SDA and clock pin CLK. The CLK input serves as data latch signal (clock). Before communication begins, a start condition must be setup on the bus by the controller. To establish a start condition, the controller must pull the data pin low while the clock pin is high.

After the start condition has been established for t_{HSTART} , an eight-bit address should be sent. The six most significant bits of the address (0111xy) are used to uniquely define devices on the bus, the 7th bit is used as a data / command control: if it is 0, then the signal on SDA is interpreted as a command; if it is 1, then data SDA is written to GDDRAM. The least significant bit is a data direction read / write control; if it is 0, then the controller writes data / command to the driver; if it is 1, then the controller reads data / command from LCD driver.

Data is transferred with the most significant bit first. Each byte has to be followed by an acknowledge bit. The transmitter releases the SDA high during the acknowledge clock pulse. The receiver has to pull down the SDA during the acknowledge clock pulse.

To end communication, a stop condition should be set up on the bus. A low to high transition of data pin while the clock pin is high defines a stop condition. However, if a master still wishes to communicate on the bus, another start condition and address can be generated without a stop condition. Refer to AC operation conditions and characteristics section for IIC Serial Interface Timing Description.

MPU Serial Peripheral Interface

The SPI consists of 4 communication bus: data input pin Din, data output pin Dout, clock pin CLK and chip enable pin \bar{CE} . The CLK input serves as data latch signal (clock).

Data is transferred serially with most significant bit first, least significant bit last. During the communication, the controller must input Low \bar{CE} before data transactions and must stay low for the rest of the transaction. By default, the LCD driver will receive command from MCU. If messages on the data pin are data rather than command, MCU should send Data Direction command (0100100X₀) to control the data direction and then one more command to define the number of data bytes will be read / write. After these two continuous commands are send, the following messages will be data rather than command. For read operation (X₀ = 1), MCU reads a group of data from LCD driver through Dout pin. For write operation (X₀ = 0), MCU writes a group of data to the LCD driver through Din pin. Refer to AC operation conditions and characteristics section for Serial Peripheral Interface Timing Description.

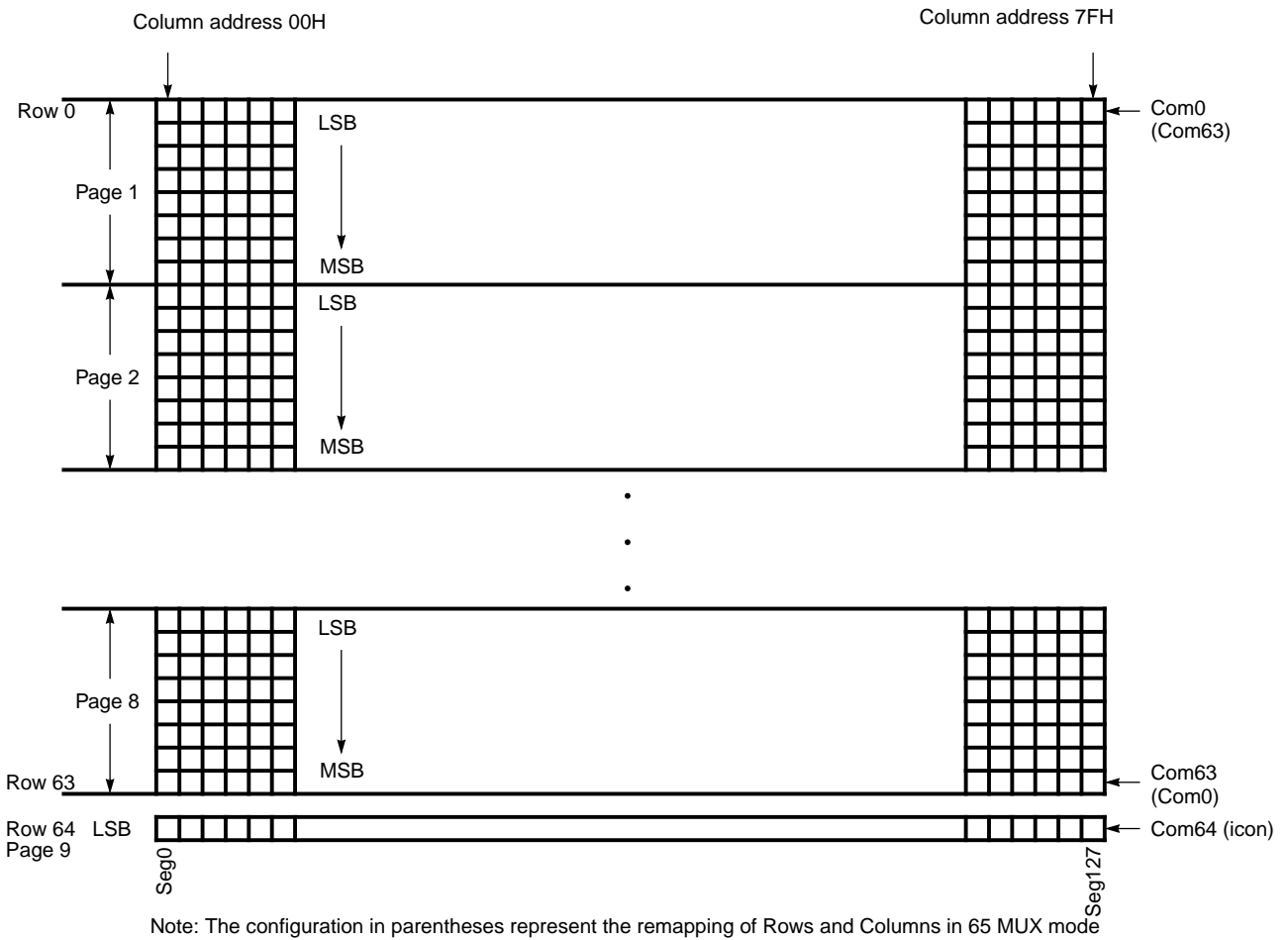

Figure 7. Graphic Display Data RAM (GDDRAM) Address Map

Graphic Display Data RAM (GDDRAM)

The GDDRAM is a bit mapped static RAM holding the bit pattern to be displayed. The size of the RAM is determined by number of row times the number of column (128x65 = 8320 bits). Figure 7 is a description of the GDDRAM address map. For mechanical flexibility, re-mapping on both Segment and Common outputs are provided.

Display Timing Generator

This module is an on chip low power RC oscillator circuitry (Figure 8). The oscillator frequency can be selected in the range of 15kHz to 250kHz by external resistor. One can enable the circuitry by software command. For external clock provided, feed the clock to OSC2 and leave OSC1 open.

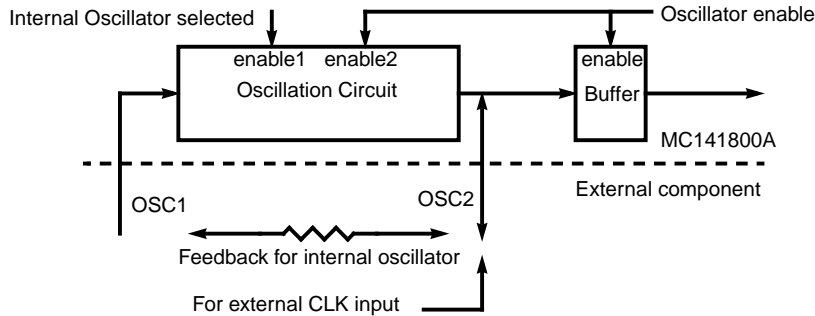

Figure 8. Oscillator Circuitry

LCD Driving Voltage Generator and Internal Regulator

This module generates the LCD voltage needed for display output. It takes a single supply input and generate necessary bias voltages. It consists of:

1. 4X and 5X DC-DC Converter
To generate the Vcc voltage. 4X DC-DC converter is used for LCD panel which needs lower driving voltage for less power consumption. 5X DC-DC converter is used for LCD panel which needs higher driving voltage.
2. Internal Regulator
Feedback gain control for initial LCD voltage. it can also be used with external contrast control.
3. Smart Bias Divider
Divide the LCD display voltage ($V_{LL2}-V_{LL6}$) from the Internal Regulator output. This is a low power consumption circuit which can save the most display current compare with traditional resistor ladder method.
4. Contrast Control Block
Software control of 16 voltage levels of LCD voltage. All blocks can be individually turned off if external voltage generator is employed
5. Bias Ratio Selection circuitry
Software control of 1/7 and 1/9 bias ratio to match the characteristic of LCD panel.

6. Self adjust temperature compensation circuitry
Provide 4 different compensation grade selections to satisfy the various liquid crystal temperature grades. The grading can be selected by software control.

65 Bit Latch / 128 Bit Latch

A register carries the display signal information. First 65 bits are Common driving signals and other 128 bits are Segment driving signals. Data will be input to the HV-buffer Cell for bumping up to the required level.

Level Selector

Level Selector is a control of the display synchronization. Display voltage can be separated into two sets and used with different cycles. Synchronization is important since it selects the required LCD voltage level to the HV Buffer Cell for output signal voltage pump.

HV Buffer Cell (Level Shifter)

HV Buffer Cell works as a level shifter which translates the low voltage output signal to the required driving voltage. The output is shifted out with an internal FRM clock which comes from the Display Timing Generator. The voltage levels are given by the level selector which is synchronized with the internal M signal.

LCD Panel Driving Waveform

The following is an example of how the Common and Segment drivers may be connected to a LCD panel. The waveforms shown in Figure 9a, 9b and 9c illustrate the desired multiplex scheme.

In order to reduce the crosstalk effect, invert the polarities of the pixel-driving waveforms every 2 or 4 or 8 or 65 lines according to the selected waveforms. In the power-up state, the default waveform will be type "B".

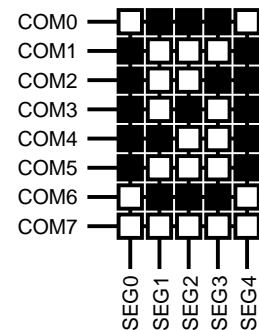

Figure 9a. LCD Display Example "0"

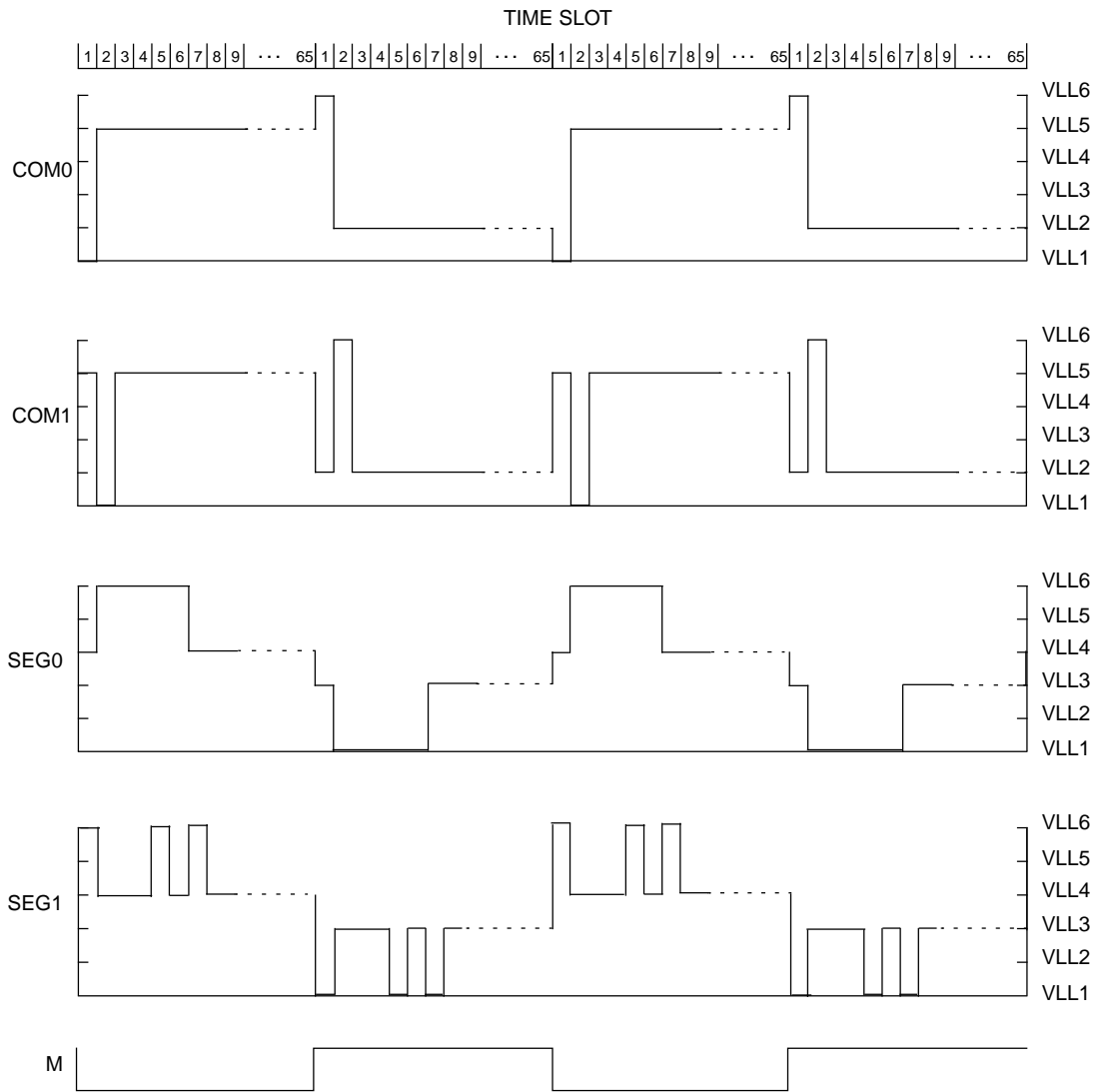

Figure 9b. LCD Driving Signal from MC141800A (Waveform B)

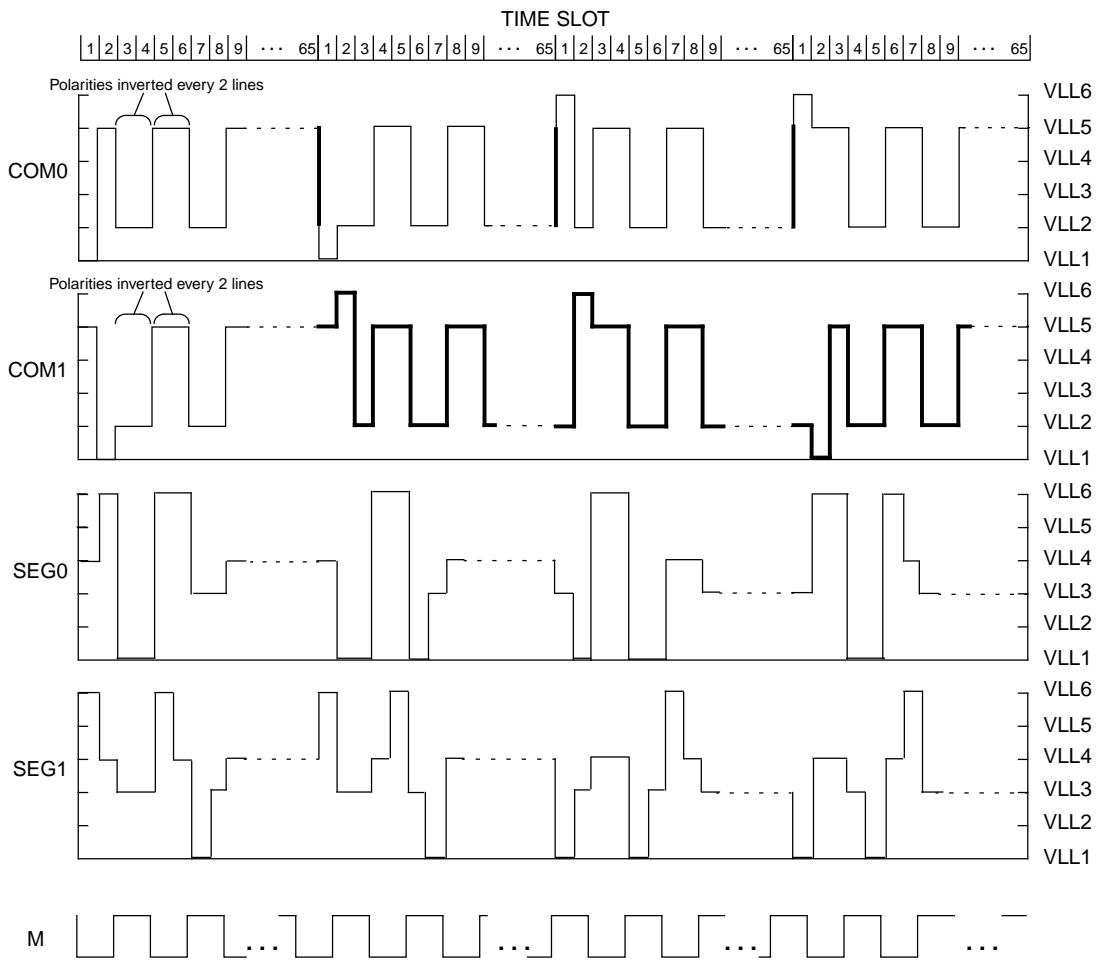

Figure 9c. LCD Driving Signal from MC141800A (Waveform C with polarity inversion every 2 lines)

Command Description

Set Display On / Off (Display Mode / Stand-by Mode)

The Display On command turns the LCD Common and Segment outputs on. This command starts the conversion of data in GDDRAM to necessary waveforms on the Common and Segment driving outputs. The on-chip bias generator is also turned on by this command. (Note: "Oscillator On" command should be sent before "Display On" is selected)

The Display Off command turn the display off and the states of the LCD driver are as follow during display off:

1. All the Common and Segment outputs are fixed at V_{LL1} (V_{SS}).
2. The bias Internal DC/DC Converter is turned off.
3. The RAM and content of all registers are retained.
4. IC will accept new commands and data.

The Oscillator is not affected by this command.

Set GDDRAM Column Address

This command positions the address pointer on a column location. The address can be set to location 00H-7FH (128 columns). The column address will be increased automatically after a read or write operation. Refer to "Address Increment Table" and command "Set GDDRAM Page Address" for further information.

Set GDDRAM Page Address

This command positions the row address to 1 of 9 possible positions in GDDRAM. Refer to figure 7.

Master Clear GDDRAM

This command is to clear the content of the Display Data RAM to zero. Issue this command followed by a dummy write command. The RAM for icon line will not be affected by this command.

Master Clear Icon

This command is a MASTER clear of the Icon Data RAM. After setting the page pointer to icon page (page 9), the internal icon RAM data will be set to Zero after the command is issued. Before using this command, set the page address to page 9 by the command "Set GDDRAM Page Address". A dummy write data is also needed after the "Master Clear Icon" command to make the clear icon action effective.

Set Page Mask (Display Mask)

The following command will be written to the Page Mask Register. Page Mask is an 8-bit register. Each bit represents one of the 8 pages: page mask bit 0 represents Page 1, page mask bit 1 represents Page 2,...etc.

Page Mask

When the Page Mask is enabled, the display of those pages, with page mask bit set, will be cleared. Meanwhile, the data in the display RAM is retained.

Icon Mask

When the Icon Mask is enabled, the display of the icons will be cleared. Meanwhile, the data in the icon display RAM is retained.

Set Display Mode

This command switch the driver to full display mode or icon display mode. In low power icon mode, only icons (driven by COM64) are displayed. Display on row 0 to row 63 will be disabled. The DC-DC converter and the Internal Regulator are off. All V_{CC} , V_{LL} pins do not have external bias voltage supply in the low power icon mode. In normal display mode, COM0 to COM64 will be turned on.

Set Display Frequency

In half display frequency mode, the display frame frequency will be halved. Also, the operation frequency of analog circuitries will be halved for power saving purpose.

Save / Restore Column Address

Save Column Address command saves a copy of the Column Address of GDDRAM. Restore Column Address command restores the copy obtained from the previous execution of saving column address. This instruction is very useful for writing full graphics characters that are larger than 8 pixels vertically.

Set Column Mapping

This instruction selects the mapping of Display Data RAM to Segment drivers for mechanical flexibility. There are 2 mappings to select:

1. Column 0 - Column 127 of GDDRAM mapped to Seg0-Seg127 respectively;
2. Column 0 - Column 127 of GDDRAM mapped to Seg127-Seg0 respectively.

COM64 will not be affected by this command. Detail information please refer to section "Display Output Description".

Set Row Mapping

This instruction selects the mapping of Display Data RAM to Common Drivers for mechanical flexibility. There are 2 selected mappings:

1. Row 0 - Row x of GDDRAM to Common 0 - Common x respectively;
2. Row 0 - Row x of GDDRAM to Common x - Common 0 respectively.

(x+2 is the multiplex ratio)

COM64 will not be affected by this command. See section "Display Output Description" for related information.

Set MUX Ratio

This command is to select any a ratio from 2 to 65. Row 64 (icon line) is not affected by this command and it would be turned on for normal display. This command contain two commands bytes, the first byte inform the driver that the second byte will be the no. of mux ratio.

- e.g. second byte = 0H to turn on Row 0 and 64 (2 MUX)
- second byte = 63H to turn on Row 0 to 64 (65 MUX)

The unused common pins output non-scanning signals.

Set Bias Ratio

This command sets the 1/7 bias or 1/9 bias for the divider output. The selection should match the characteristic of LCD Panel.

Set Oscillator Disable / Enable

This command is used to either turn on / off Oscillator. For using internal or external oscillator, this command should be executed. The setting for this command is not affected by command "Set Display On/Off". See command "Ext/Int Oscillator" for more information.

Set Internal / External Oscillator

This command is used to select either internal or external oscillator. When internal oscillator is selected, feedback resistor between OSC1 and OSC2 is needed. For external oscillation circuit, feed clock input signal to OSC2 and leave OSC1 open.

Set Internal DC/DC Converter Enable

Use this command to select the Internal DC/DC Converter to generate the V_{CC} from V_{DD} . Disable the Internal DC/DC Converter if external V_{CC} is provided.

Set 4X / 5X DC/DC Converter

This command selects the usage of 4X or 5X Converter when the Internal DC/DC Converter is enabled.

Set Temperature Coefficient

A temperature gradient selector circuit controlled by two control bits TC1 and TC2. This command can select 4 different LCD driving voltage temperature coefficients to match various liquid crystal temperature grades.

Set Internal Regulator On/Off

Choose bit option 0 to disable the on chip Internal Regulator. Choose bit option 1 to enables Internal Regulator which consists of the internal contrast control circuits.

Set Smart Bias Divider On/Off

If the Smart Bias Divider is disabled, external bias can be used for V_{LL6} to V_{LL2} . If the Smart Bias Divider is enabled, the internal circuit will generated the 1:7 or 1:9 bias driving voltage.

End of Command

This command is used as extra write end command follows the last byte of data / command written. This command is not available if serial mode is selected.

Set Internal Contrast Control Enable

This command is used to adjust the delta voltage of the bias voltages. With bit option = 1, the software selection for delta bias voltage control is enabled. With bit option = 0, internal contrast control is disabled.

Increase / Decrease Contrast Level

If the internal contrast control is enabled, this command is used to increase or decrease the contrast level within the 16 contrast levels. The contrast level starts from lowest value after POR.

Set Contrast Level

This command is to select one of the 16 contrast levels when internal contrast control circuitry is in use. After power-on reset, the contrast level is lowest.

Set Smart Icon Mode

This command is to set 4-Phase or 6-Phase smart icon modes which for lower VDD or higher Von of panel. Refer to Smart Icon Mode Output Description for detail.

Set Display Waveform Type

This command will select the number of lines for the polarity inversion of the driving waveform. Four types of waveform types are available. Refer to Figure 9.

Set Data Direction

This command is used in SPI mode only. It will be two continuous commands, the first byte control the data direction and inform the LCD driver the second byte will be number of data bytes will be read / write. After these two commands sending out, the following messages will be data.

COMMAND TABLE

Bit Pattern	Command	Comment
0000 $X_3X_2X_1X_0$	Set GDDRAM Page Address	Set GDDRAM Page Address using $X_3X_2X_1X_0$ as address bits. $X_3X_2X_1X_0=0000$: page 1 (POR) $X_3X_2X_1X_0=0001$: page 2 $X_3X_2X_1X_0=0010$: page 3 $X_3X_2X_1X_0=0011$: page 4 $X_3X_2X_1X_0=0100$: page 5 $X_3X_2X_1X_0=0101$: page 6 $X_3X_2X_1X_0=0110$: page 7 $X_3X_2X_1X_0=0111$: page 8 $X_3X_2X_1X_0=1000$: page 9
0001 $X_3X_2X_1X_0$	Set Contrast Level	With R/\bar{W} pin input low, set one of the 16 available values to the internal contrast register, using $X_3X_2X_1X_0$ as data bits. The contrast register is reset to 0000 during POR.
0010000 X_0	Set 4X / 5X DC-DC Converter	$X_0=0$: enable 4X Converter (POR) $X_0=1$: enable 5X Converter
0010001 X_0	Set Segment Mapping	$X_0=0$: Col0 to Seg0 (POR) $X_0=1$: Col0 to Seg127
0010010 X_0	Set Common Mapping	$X_0=0$: Row0 to Com0 (POR) $X_0=1$: Row0 to Com63
0010100 X_0	Set Display on/off	$X_0=0$: display off (POR) $X_0=1$: display on
0010101 X_0	Set Internal DC/DC Converter On/Off	$X_0=0$: Internal DC/DC Converter Off (POR) $X_0=1$: Internal DC/DC Converter On
0010110 X_0	Set Internal Regulator On/Off	$X_0=0$: Internal Regulator Off(POR) $X_0=1$: Internal Regulator On
0010111 X_0	Set Smart Bias Divider On/Off	$X_0=0$: Smart Bias Divider Off (POR) $X_0=1$: Smart Bias Divider On When an external bias network is preferred, the Smart Bias Divider should be disabled.

COMMAND TABLE

Bit Pattern	Command	Comment
0011000X ₀	Set Internal Contrast Control On/Off	X ₀ =0: Internal Contrast Control Off(POR) X ₀ =1: Internal Contrast Control On Internal contrast circuits can be disabled if external contrast circuits is preferred.
0011001X ₀	Set Display Frequency	X ₀ =0 : normal display frequency (POR) X ₀ =1 : half display frequency
0011010X ₀	Save/Restore GDDRAM Column Address	X ₀ =0 : restore address X ₀ =1 : save address
00110110	Master Clear GDDRAM	Master clear GDDRAM (64 x 128 bits), row 64 (icon line) will not be cleared
00110111	Master Clear Icons	Master Clear of Icons
0011100X ₀	Set Bias Ratio	X ₀ =0 : bias = 1 : 9 (POR) X ₀ =1 : bias = 1 : 7
0011101X ₀	Reserved	X ₀ =0 : Normal Operation (POR) X ₀ =1 : Test Mode 1 Select (Note : Make sure to set X ₀ =0 during application)
00111100	End of Command	Write command to identify end of data frame
0011111X ₀	Set Display Mode	X ₀ =0 : low power icon display mode X ₀ =1 : normal display mode (POR)
01000000	Set Multiplex Ratio	next command will define no. of MUX, 00X ₅ X ₄ X ₃ X ₂ X ₁ X ₀ no. of mux=00111111 upon POR (65 MUX)
01000001	Set Page Mask	next command will be written to page mask register page mask register=0 upon POR
0100010X ₀	Page Mask	X ₀ =0 : disable page mask (POR) X ₀ =1 : enable page mask
0100011X ₀	Icon Mask	X ₀ =0 : disable icon mask (POR) X ₀ =1 : enable icon mask
0100100X ₀	Set Data Direction (for SPI mode only)	X ₀ =0 : Write Data (POR) X ₀ =1 : Read Data next command will define the total number of data bytes will be read / write e.g. no. of data bytes = 01111111 for 128 bytes
0100101X ₀	Reserved	X ₀ =0 : Select Switch Resistor as HV divider (POR) X ₀ =1 : Select Buffer as HV divider
0100110X ₀	Reserved	X ₀ =0 : Select 500ohm in switch resistor divider (POR) X ₀ =1 : Select 1kohm in switch resistor divider
01010100	Reserved	next command will define Smart Divider value, 000X ₄ X ₃ X ₂ X ₁ X ₀
0101001X ₀	Reserved	X ₀ =0 : Use diode approach for temperature compensation (POR) X ₀ =1 : Use band gap technique for temperature compensation
011001X ₁ X ₀	Set Display Waveform Type	X ₁ X ₀ =00 : Waveform Type B (POR) X ₁ X ₀ =01 : Waveform Type C with polarity inversion every 8 lines X ₁ X ₀ =10 : Waveform Type C with polarity inversion every 4 lines X ₁ X ₀ =11 : Waveform Type C with polarity inversion every 2 lines
0110100X ₀	Set Smart Icon Mode	X ₀ =1 : 4-Phase Smart Icon X ₀ =0 : 6-Phase Smart Icon (POR)
011011X ₁ X ₀	Set Temperature Coefficient	X ₁ X ₀ =: 0.00% (POR) X ₁ X ₀ =: -0.18% X ₁ X ₀ =: -0.22% X ₁ X ₀ =: -0.35%
0111000X ₀	Increase / Decrease Contrast Level	X ₀ =0: Decrease by one level X ₀ =1: Increase by one level (Note: increment/decrement wraps round among the 16 contrast levels. Start at the lowest level when POR.

COMMAND TABLE

Bit Pattern	Command	Comment
0111011X ₀	Reserved	X ₀ =0: Normal Operation (POR) X ₀ =1: Test Mode 2 Select (Note: Make sure to set X ₀ =0 during application)
0111101X ₀	Set Internal / External Oscillator	X ₀ =0: Internal oscillator (POR) X ₀ =1: External oscillator. For internal oscillator place a resistor between OSC1 and OSC2. For external oscillator mode, feed clock input to OSC2.
0111111X ₀	Set Oscillator On/Off	X ₀ =0: oscillator Off (POR) X ₀ =1: oscillator On. This is the master control for oscillator circuitry. This command should be issued after the "Set Internal / External Oscillator" command.
1X ₆ X ₅ X ₄ X ₃ X ₂ X ₁ X ₀	Set GDDRAM Column Address	Set GDDRAM Column Address. Use X ₆ X ₅ X ₄ X ₃ X ₂ X ₁ X ₀ as address bits.

Data Read / Write

To read data from the GDDRAM, input High to R \overline{W} pin and D \overline{C} pin in parallel mode or pull high at the 7th and 8th bit of the address in IIC serial mode or send Data Direction command 01001001 in SPI mode. Data is valid at the falling edge of CLK. And the GDDRAM column address pointer will be increased by one automatically.

To write data to the GDDRAM, input Low to R \overline{W} pin and High to D \overline{C} pin in parallel mode or pull low 7th bit and high 8th bit of the address in IIC serial mode or send Data Direction command 01001000 in SPI mode. Data is latched at the falling edge of CLK. And the GDDRAM column address pointer will be increased by one automatically. If parallel interface is selected, End of command should be followed after all data are send out.

No auto address pointer increment will be performed for the Dummy Write Data after Master Clear GDDRAM. (Refer to the "Commands Required for R \overline{W} Actions on RAM" Table)

Address Increment Table (Automatic)

D \overline{C}	R \overline{W}	Comment	Address Increment	Remarks
0	0	Write Command	No	
0	1	Read Command	No (invalid mode)	*1
1	0	Write Data	Yes	*2
1	1	Read Data	Yes	

Address Increment is done automatically data read write. The column address pointer of GDDRAM^{*3} is affected.

Remarks: *1. Only data is read from RAM.

*2. If write data is issued after Command Clear RAM, Address increase is not applied.

*3. Column Address will wrap round when overflow.

Commands Required for R/W Actions on RAM

R/W Actions on RAMs	Commands Required	
Read/Write Data from/to GDDRAM.	Set GDDRAM Page Address Set GDDRAM Column Address Read/Write Data End of command	(0000X ₃ X ₂ X ₁ X ₀)* (1X ₆ X ₅ X ₄ X ₃ X ₂ X ₁ X ₀)* (X ₇ X ₆ X ₅ X ₄ X ₃ X ₂ X ₁ X ₀) (00111100)
Save/Restore GDDRAM Column Address.	Save/Restore GDDRAM Column Address End of command	(0011010X ₀) (00111100)
Master Clear GDDRAM	Set Clear Page GDDRAM (64 x 128 bits) Dummy Write Data	(00110110) (X ₇ X ₆ X ₅ X ₄ X ₃ X ₂ X ₁ X ₀)
Master Clear Icon RAM	Set GDDRAM Page Address to Page 9 Master Clear Icon RAM (128 bits, row 64) Dummy Write Data	(00001000) (00110111) (X ₇ X ₆ X ₅ X ₄ X ₃ X ₂ X ₁ X ₀)

* No need to resend the command again if it is set previously.

The read / write action to the Display Data RAM does not depend on the display mode. This means the user can change the RAM content whether the target RAM content is being displayed.

Display Output Description

This is an example of output pattern on the LCD panel. Figure 10b and 10c are data map of GDDRAM and the output pattern on the LCD display with different command enabled.

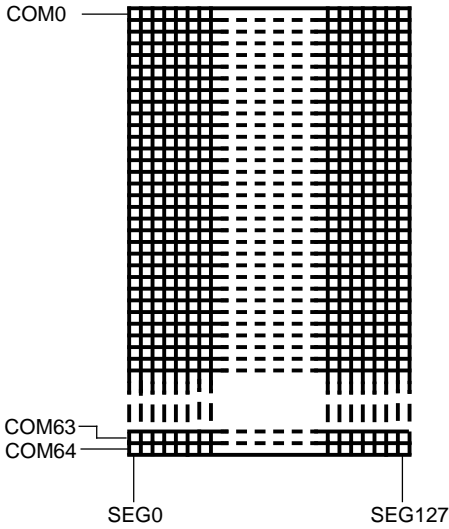

Figure 10a

		Content of GDDRAM
PAGE 1	Upper Nibble	5 A 5 A 5 A 5 A 5 A 5 A - - - - - 5 A 5 A 5 A 5 A 5 A
	Lower Nibble	5 A 5 A 5 A 5 A 5 A 5 A - - - - - 5 A 5 A 5 A 5 A 5 A
PAGE 2	Upper Nibble	3 3 C C 3 3 C C 3 3 - - - - - C C 3 3 C C 3 3 C C
	Lower Nibble	3 3 C C 3 3 C C 3 3 - - - - - C C 3 3 C C 3 3 C C
PAGE 3	Upper Nibble	0 0 0 0 F F F F 0 0 - - - - - F F 0 0 0 0 F F F F
	Lower Nibble	F F F F 0 0 0 0 F F - - - - - 0 0 F F F F 0 0 0 0
PAGE 4	Upper Nibble	F F F F F F F F 0 0 - - - - - F F 0 0 0 0 0 0 0 0
	Lower Nibble	F F F F F F F F 0 0 - - - - - F F 0 0 0 0 0 0 0 0
.	.	.
.	.	.
.	.	.
PAGE 9	Upper Nibble	0 0 0 0 0 0 0 0 0 0 - - - - - 0 0 0 0 0 0 0 0 0 0
	Lower Nibble	0 0 0 1 1 1 0 0 0 0 - - - - - 0 0 0 0 1 1 1 0 0 0

Figure 10b

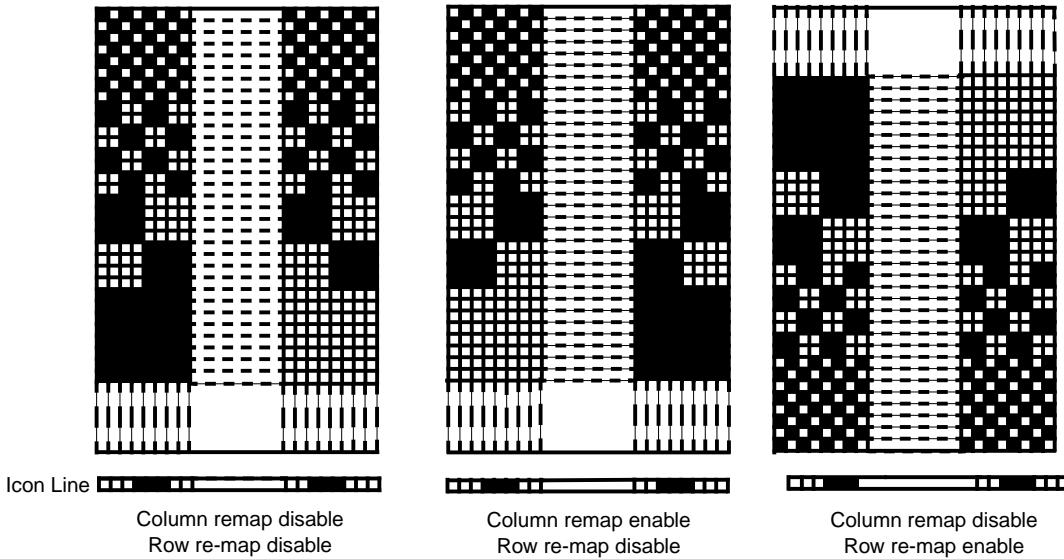

Figure 10c. Examples of LCD display with different command enabled

Power Up Sequence (Commands Required)

Command Required	POR Status	Remarks
Set Display Frequency	Normal	*1
Set Oscillator Enable	Disable	*1
Set MUX Ratio	65 MUX	*1
Set Bias Ratio	1/9 bias	*1
Set Internal DC/DC Converter	4X Converter	*1
Set Internal Regulator On	Off	*1
Set Temperature Coefficient	TC=0%	*1, *3
Set Internal Contrast Control On	Off	*1, *3
Set Contrast Level	Contrast Level = 0	*1, *2, *3
Set Smart Bias Divider On	Off	*1
Set Segment Mapping	Seg. 0 = Col. 0	
Set Common Mapping	Com. 0 = Row 0	
Set Display On	Off	

Remarks:

- *1 -- Required only if desired status differ from POR.
- *2 -- Effective only if Internal Contrast Control is enabled.
- *3 -- Effective only if Internal Regulator is enabled.

Smart Icon Mode Output Description

There are two driving schemes of Smart Icon Mode for panel with different V_{on}/V_{off} or V_{DD} :

- 1) 4 - Phase Smart Icon: 1/4 ~ 3/4
 - $V_{off} > V_{DD} * \text{sqrt}(1/4)$
 - $V_{on} < V_{DD} * \text{sqrt}(3/4)$
- 2) 6 - Phase Smart Icon: 1/6 ~ 3/6
 - $V_{off} > V_{DD} * \text{sqrt}(1/6)$
 - $V_{on} < V_{DD} * \text{sqrt}(3/6)$

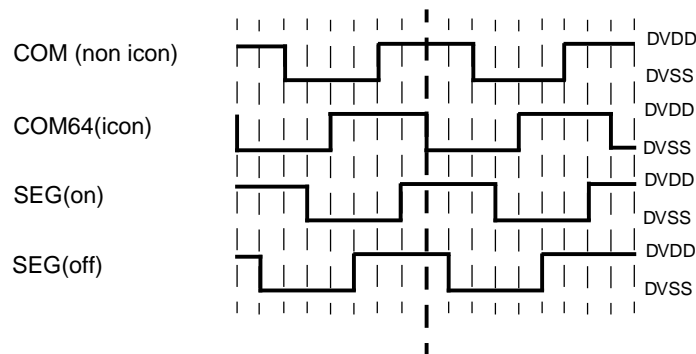

Figure 11a. LCD Driving Signal for 4 - Phase Smart Icon Mode

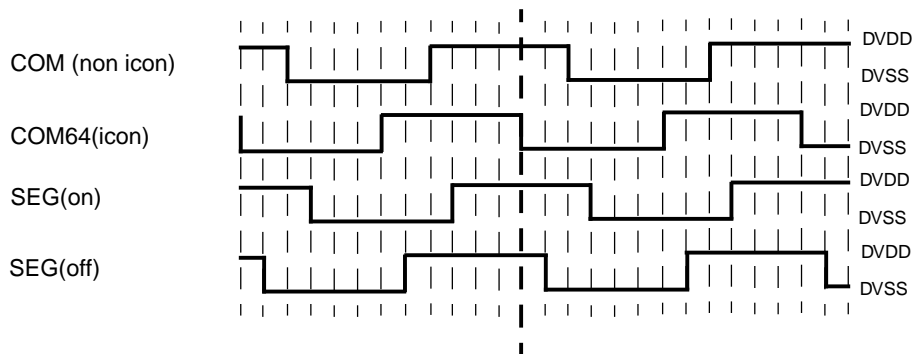
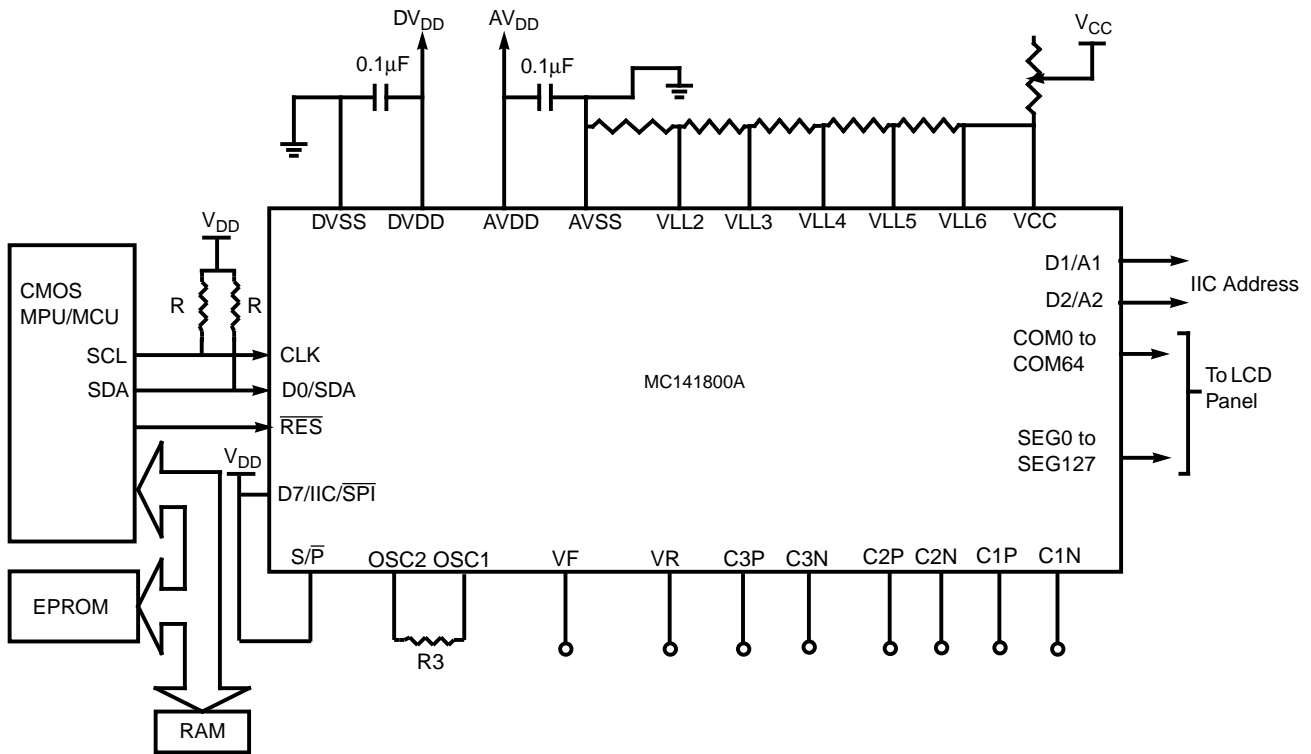

Figure 11b. LCD Driving Signal for 6 - Phase Smart Icon Mode

Application Circuit:

All Internal Analog Circuitry disabled at IIC Serial mode operation



Remark:

1. R3 can be omitted for external oscillator.
2. \overline{RES} should be at a known state.
3. VLL2 - VLL6 can be left open for internal divider is enable.
4. $\overline{R/W}$, \overline{CE} , $\overline{D/C}$ and D3-D6 can be open for IIC serial mode.
5. D1/A1 and D2/A2 should be at predefined state for device identification.
6. R is pull up resistance, $R < \frac{t_r}{2 * C_{bus}}$ (R = 300 ohm for 1MHz, assume $C_{bus} = 200pF$)

All Internal Analog Circuitry enabled at IIC Serial mode operation

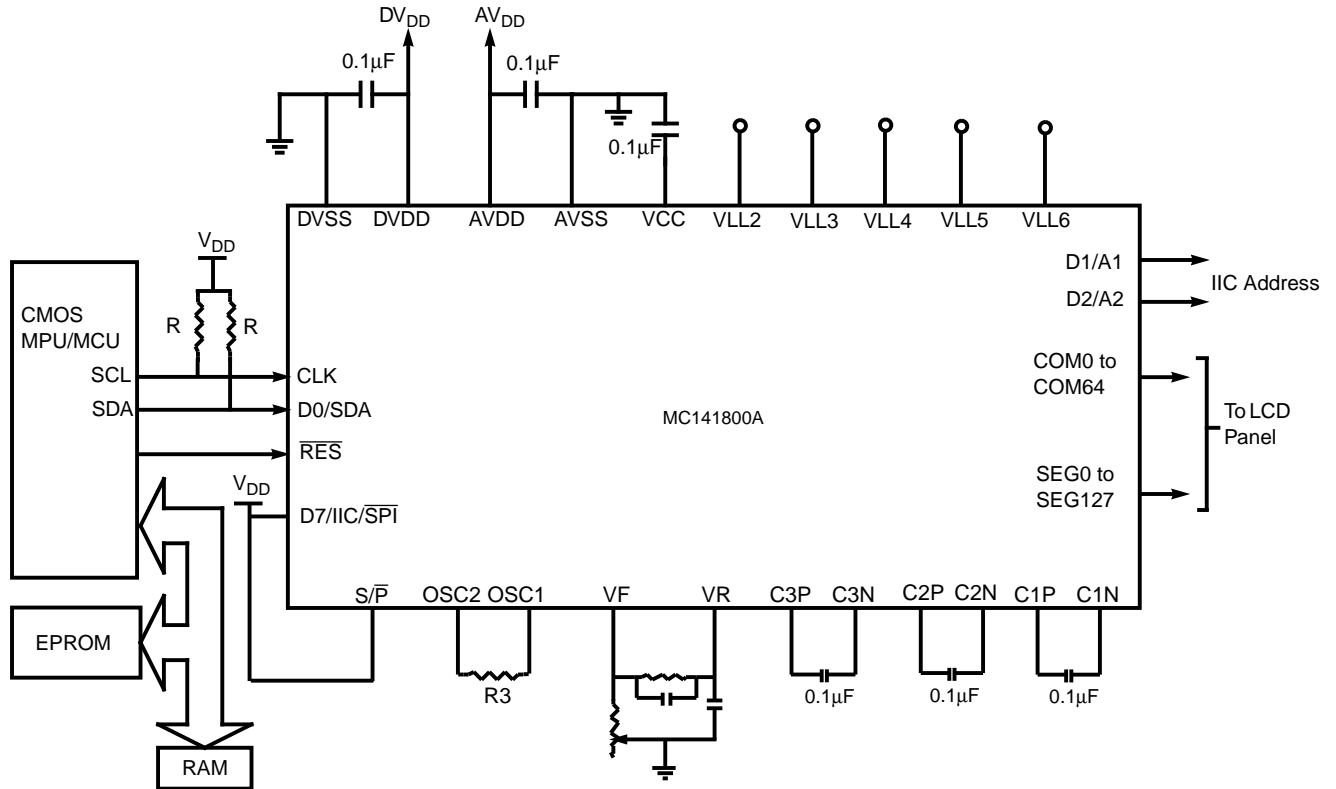

Remark:

1. R3 can be omitted for external oscillator.
2. VR and VF can be left open for Internal Regulator disable and Contrast Disable.
3. $\overline{\text{RES}}$ should be at a known state.
4. R/W, $\overline{\text{CE}}$, D/C and D3-D6 can be open for IIC serial mode.
5. D1/A1 and D2/A2 should be at predefined state for device identification.
6. R is pull up resistance, $R < \frac{t_r}{2 * C_{\text{bus}}}$ (R = 300 ohm for 1MHz, assume $C_{\text{bus}} = 200\text{pF}$)

All Internal Analog Circuitry disabled at SPI Serial mode operation

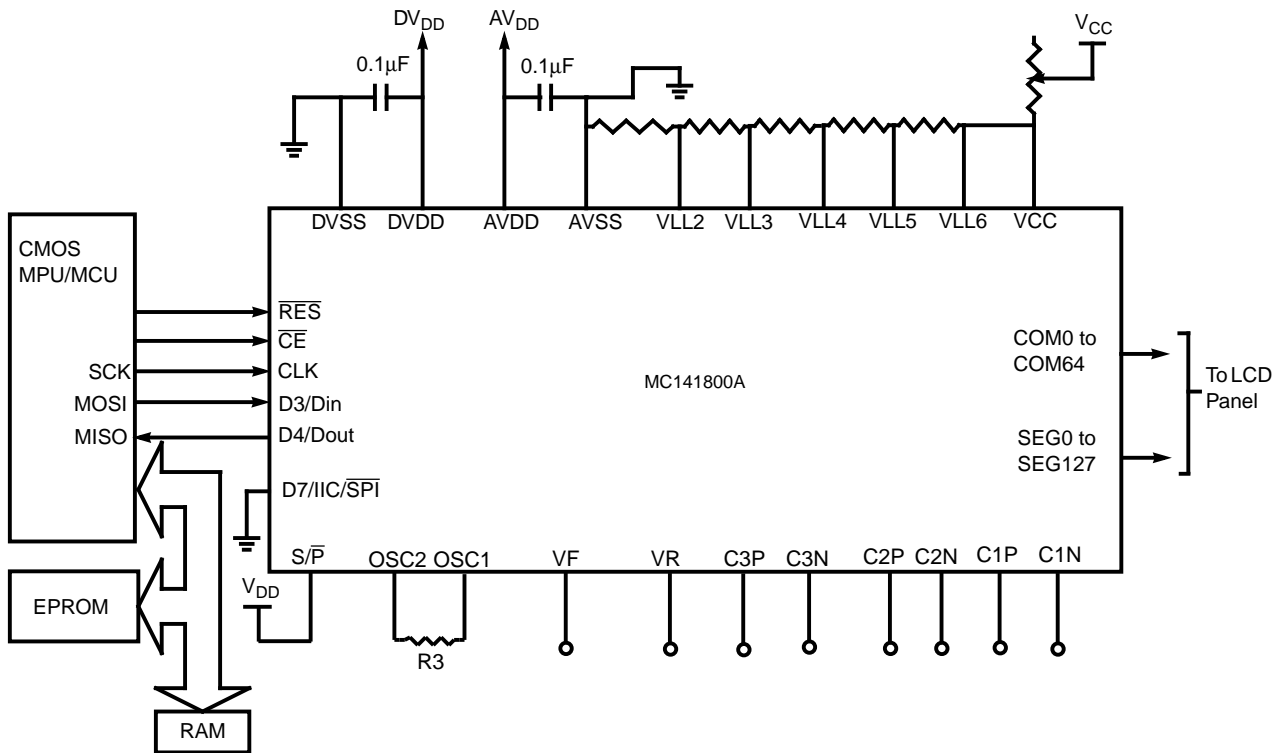

Remark:

1. R3 can be omitted for external oscillator.
2. RES should be at a known state.
3. VLL2 - VLL6 can be left open for internal divider is enable.
4. R/W, D/C, D0-2 and D5-6 can be open for SPI serial mode.

All Internal Analog Circuitry enabled at SPI Serial mode operation

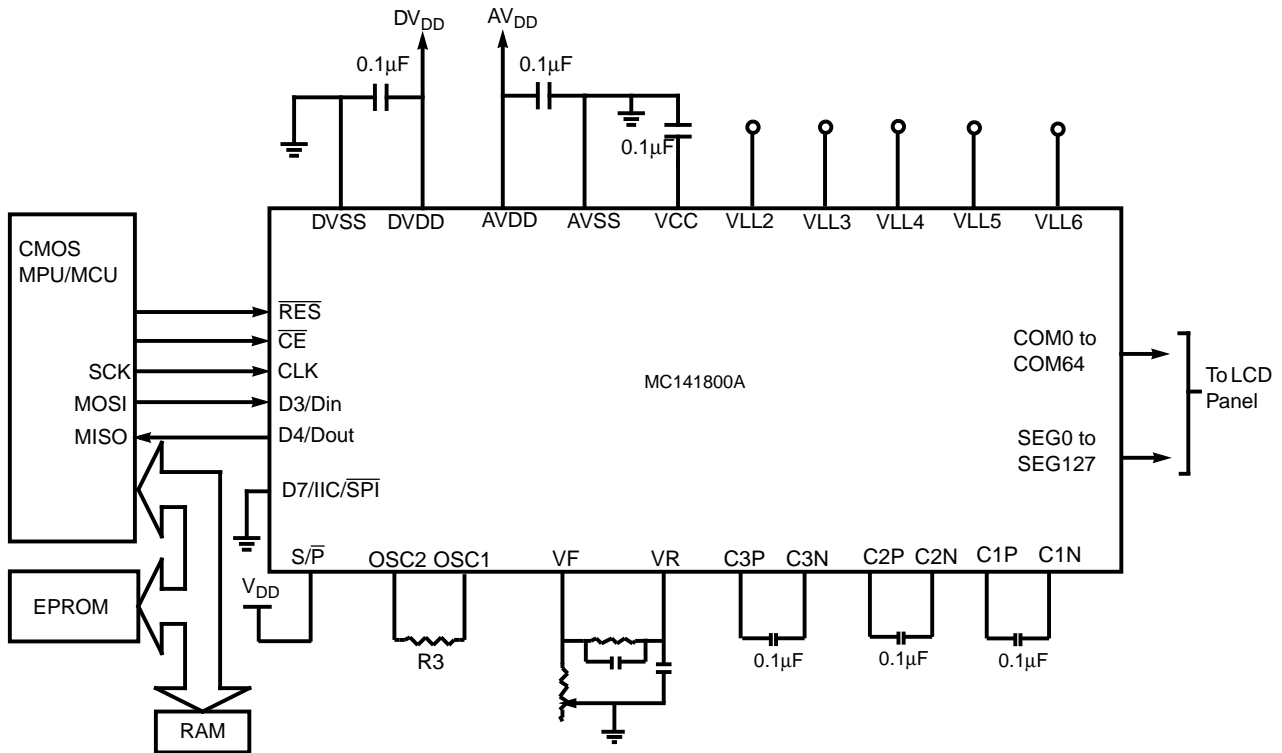

Remark:

1. R3 can be omitted for external oscillator.
2. VR and VF can be left open for Internal Regulator disable and Contrast Disable.
3. RES should be at a known state.
4. R/\bar{W} , D/\bar{C} , D0-2 and D5-6 can be open for SPI serial mode.

All Internal Analog Circuitry disabled at Parallel mode operation

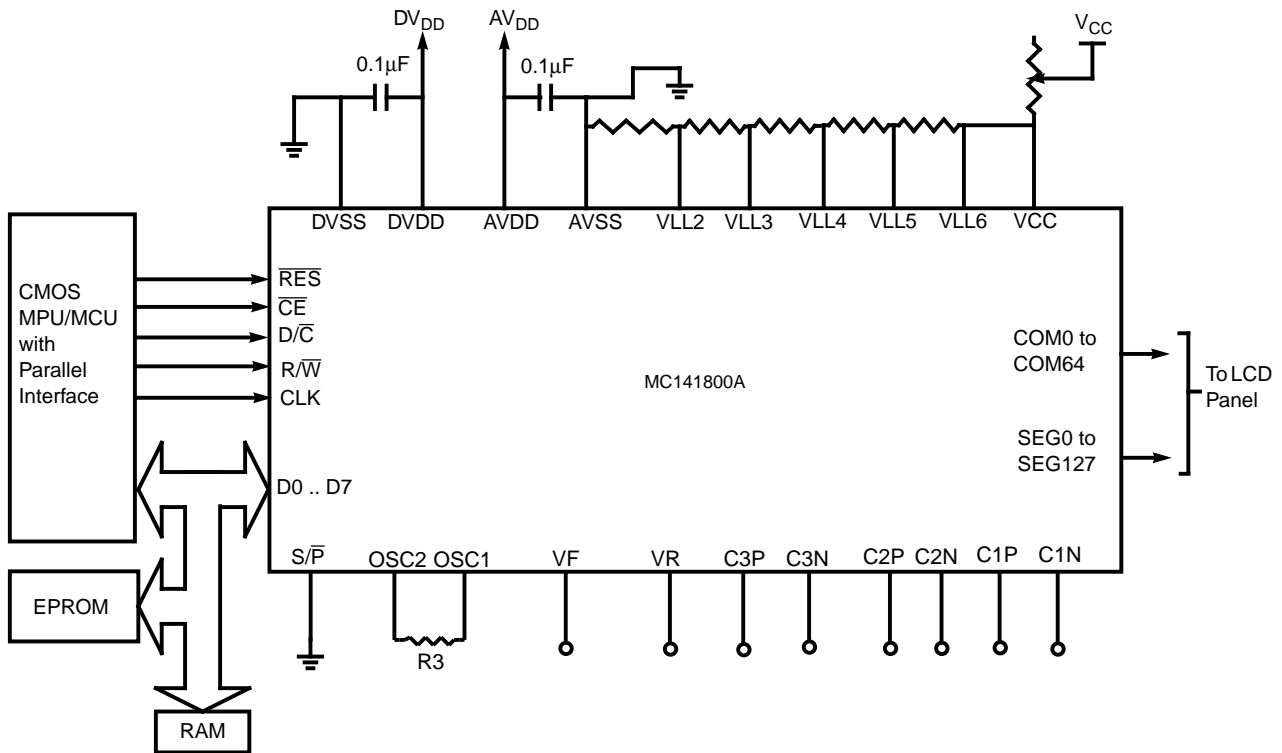

Remark:

1. R3 can be omitted for external oscillator.
2. RES should be at a known state.
3. VLL2 - VLL6 can be left open for internal divider is enable.

All Internal Analog Circuitry enabled at Parallel mode operation

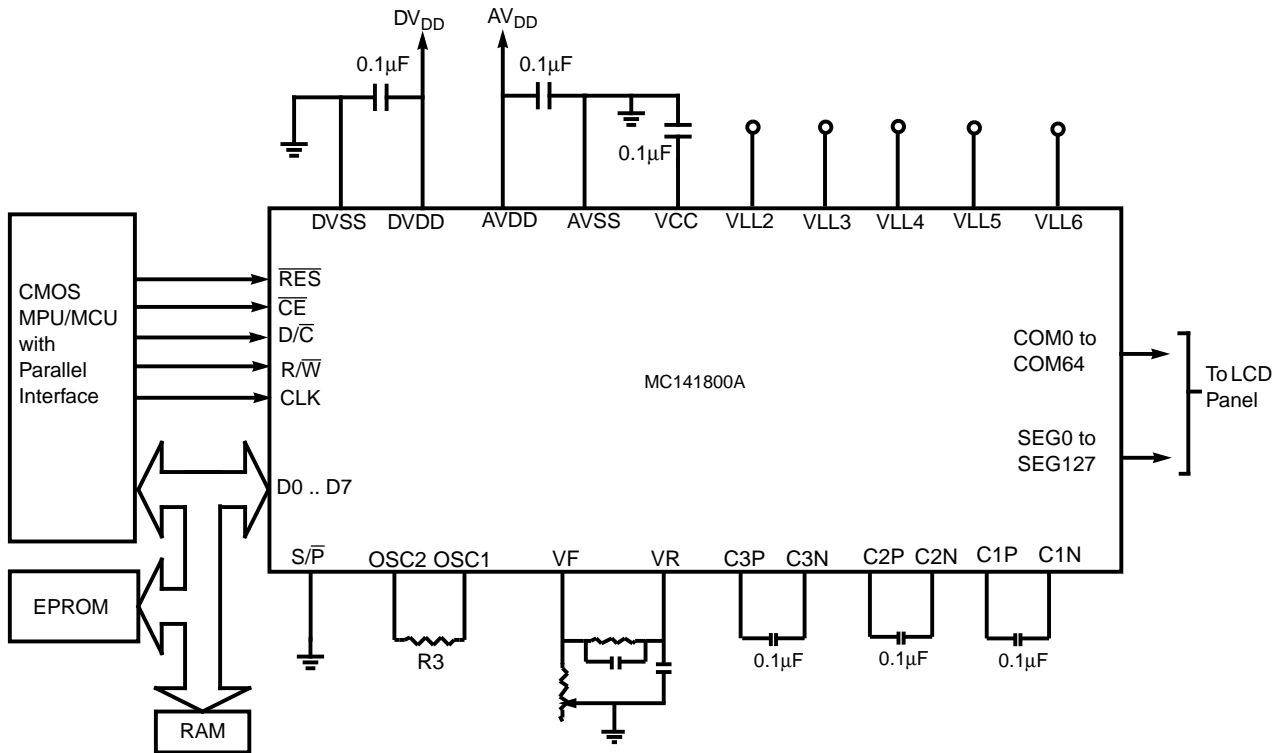

Remark:

1. R3 can be omitted for external oscillator.
2. VR and VF can be left open for Internal Regulator disable and Contrast Disable.
3. RES should be at a known state.

PACKAGE DIMENSIONS
MC141800AT
TAB PACKAGE DIMENSION - 2
(DO NOT SCALE THIS DRAWING)

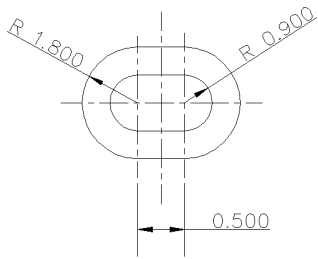

DETAIL C

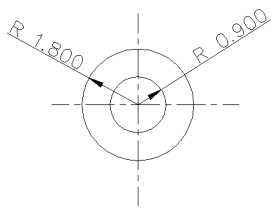

DETAIL B

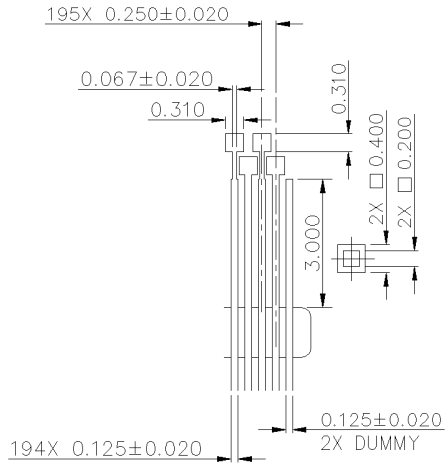

DETAIL A

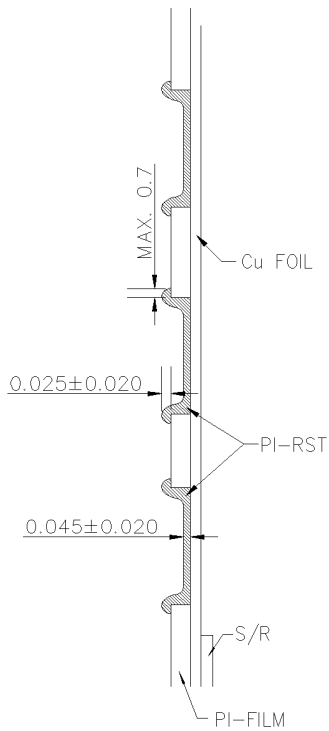

FLEX MATERIAL DETAIL

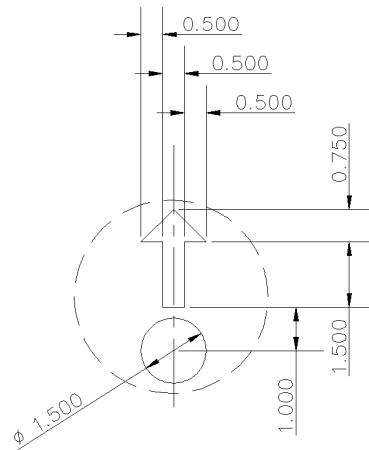

DETAIL D

Reference: 98ASL00269A Issue "0" released on 11 Feb 97

Die Pad Coordinate of MC141800A

Pad	Name	X(um)	Y(um)	Pad	Name	X(um)	Y(um)	Pad	Name	X(um)	Y(um)	Pad	Name	X(um)	Y(um)	Pad	Name	X(um)	Y(um)
1	COM(22)	-4826.0	-807.6	61	C3P	1198.4	-857.8	121	SEG(0)	4826.0	807.6	181	SEG(60)	266.0	807.6	241	SEG(120)	-4294.0	807.6
2	COM(23)	-4750.0	-807.6	62	C3N	1304.4	-857.8	122	SEG(1)	4750.0	807.6	182	SEG(61)	190.0	807.6	242	SEG(121)	-4370.0	807.6
3	COM(24)	-4674.4	-811.8	63	VLL2:	1410.4	-857.8	123	SEG(2)	4674.0	807.6	183	SEG(62)	114.0	807.6	243	SEG(122)	-4446.0	807.6
4	COM(25)	-4598.0	-807.6	64	VLL2:	1516.4	-857.8	124	SEG(3)	4598.0	807.6	184	SEG(63)	38.0	807.6	244	SEG(123)	-4522.0	807.6
5	COM(26)	-4522.0	-807.6	65	VLL3:	1622.4	-857.8	125	SEG(4)	4522.0	807.6	185	SEG(64)	-38.0	807.6	245	SEG(124)	-4598.0	807.6
6	COM(27)	-4446.0	-807.6	66	VLL3:	1728.4	-857.8	126	SEG(5)	4446.0	807.6	186	SEG(65)	-114.0	807.6	246	SEG(125)	-4674.0	807.6
7	COM(28)	-4370.0	-807.6	67	VLL4:	1834.4	-857.8	127	SEG(6)	4370.0	807.6	187	SEG(66)	-190.0	807.6	247	SEG(126)	-4750.0	807.6
8	COM(29)	-4294.0	-807.6	68	VLL4:	1940.4	-857.8	128	SEG(7)	4294.0	807.6	188	SEG(67)	-266.0	807.6	248	SEG(127)	-4826.0	807.6
9	COM(30)	-4218.0	-807.6	69	VLL5:	2046.4	-857.8	129	SEG(8)	4218.0	807.6	189	SEG(68)	-342.0	807.6	249	COM64B	-5328.4	835.4
10	COM(31)	-4142.0	-807.6	70	VLL5:	2152.4	-857.8	130	SEG(9)	4142.0	807.6	190	SEG(69)	-418.0	807.6	250	COM(0)	-5328.4	759.4
11	DVDD:	-4042.2	-857.8	71	VLL6:	2258.4	-857.8	131	SEG(10)	4066.0	807.6	191	SEG(70)	-494.0	807.6	251	COM(1)	-5328.4	683.4
12	S/P	-3940.6	-857.8	72	VLL6:	2364.4	-857.8	132	SEG(11)	3990.0	807.6	192	SEG(71)	-570.0	807.6	252	COM(2)	-5328.4	607.4
13	RES	-3839.0	-857.8	73	DVSS:	2470.4	-857.8	133	SEG(12)	3914.0	807.6	193	SEG(72)	-646.0	807.6	253	COM(3)	-5328.4	531.4
14	D/C	-3737.4	-857.8	74	OSC1	2576.4	-857.8	134	SEG(13)	3838.0	807.6	194	SEG(73)	-722.0	807.6	254	COM(4)	-5328.4	455.4
15	DVSS:	-3569.0	-857.8	75	DVSS:	2682.4	-857.8	135	SEG(14)	3762.0	807.6	195	SEG(74)	-798.0	807.6	255	COM(5)	-5328.4	379.4
16	DVSS:	-3467.4	-857.8	76	DVSS:	2788.4	-857.8	136	SEG(15)	3686.0	807.6	196	SEG(75)	-874.0	807.6	256	COM(6)	-5328.4	303.4
17	DVSS:	-3365.8	-857.8	77	VCC:	2894.4	-857.8	137	SEG(16)	3610.0	807.6	197	SEG(76)	-950.0	807.6	257	COM(7)	-5328.4	227.4
18	DVSS:	-3264.2	-857.8	78	VCC:	3000.4	-857.8	138	SEG(17)	3534.0	807.6	198	SEG(77)	-1026.0	807.6	258	COM(8)	-5328.4	151.4
19	DVSS:	-3162.6	-857.8	79	AVSS:	3106.4	-857.8	139	SEG(18)	3458.0	807.6	199	SEG(78)	-1102.0	807.6	259	COM(9)	-5328.4	75.4
20	DVSS:	-3061.0	-857.8	80	OSC2	3212.4	-857.8	140	SEG(19)	3382.0	807.6	200	SEG(79)	-1178.0	807.6	260	COM(10)	-5328.4	-0.6
21	DVSS:	-2959.4	-857.8	81	AVDD:	3318.4	-857.8	141	SEG(20)	3306.0	807.6	201	SEG(80)	-1254.0	807.6	261	COM(11)	-5328.4	-76.6
22	DVSS:	-2857.8	-857.8	82	DVSS:	3493.0	-857.8	142	SEG(21)	3230.0	807.6	202	SEG(81)	-1330.0	807.6	262	COM(12)	-5328.4	-152.6
23	DVSS:	-2756.2	-857.8	83	DVSS:	3594.6	-857.8	143	SEG(22)	3154.0	807.6	203	SEG(82)	-1406.0	807.6	263	COM(13)	-5328.4	-228.6
24	DVSS:	-2654.6	-857.8	84	DVSS:	3696.2	-857.8	144	SEG(23)	3078.0	807.6	204	SEG(83)	-1482.0	807.6	264	COM(14)	-5328.4	-304.6
25	DVSS:	-2553.0	-857.8	85	DVSS:	3797.8	-857.8	145	SEG(24)	3002.0	807.6	205	SEG(84)	-1558.0	807.6	265	COM(15)	-5328.4	-380.6
26	DVSS:	-2451.4	-857.8	86	DVSS:	3899.4	-857.8	146	SEG(25)	2926.0	807.6	206	SEG(85)	-1634.0	807.6	266	COM(16)	-5328.4	-456.6
27	DVSS:	-2349.8	-857.8	87	DVSS:	4001.0	-857.8	147	SEG(26)	2850.0	807.6	207	SEG(86)	-1710.0	807.6	267	COM(17)	-5328.4	-532.6
28	DVSS:	-2248.2	-857.8	88	COM64A	4142.0	-807.6	148	SEG(27)	2774.0	807.6	208	SEG(87)	-1786.0	807.6	268	COM(18)	-5328.4	-608.6
29	DVSS:	-2146.6	-857.8	89	COM(63)	4217.0	-806.2	149	SEG(28)	2698.0	807.6	209	SEG(88)	-1862.0	807.6	269	COM(19)	-5328.4	-684.6
30	DVSS:	-2045.0	-857.8	90	COM(62)	4293.0	-806.2	150	SEG(29)	2622.0	807.6	210	SEG(89)	-1938.0	807.6	270	COM(20)	-5328.4	-760.6
31	DVSS:	-1943.4	-857.8	91	COM(61)	4369.0	-806.2	151	SEG(30)	2546.0	807.6	211	SEG(90)	-2014.0	807.6	271	COM(21)	-5328.4	-836.6
32	DVSS:	-1841.8	-857.8	92	COM(60)	4445.0	-806.2	152	SEG(31)	2470.0	807.6	212	SEG(91)	-2090.0	807.6				
33	DVSS:	-1740.2	-857.8	93	COM(59)	4521.0	-806.2	153	SEG(32)	2394.0	807.6	213	SEG(92)	-2166.0	807.6				
34	R/W	-1638.6	-857.8	94	COM(58)	4597.0	-806.2	154	SEG(33)	2318.0	807.6	214	SEG(93)	-2242.0	807.6				
35	D7	-1537.0	-857.8	95	COM(57)	4673.0	-806.2	155	SEG(34)	2242.0	807.6	215	SEG(94)	-2318.0	807.6				
36	D6	-1435.4	-857.8	96	COM(56)	4749.0	-806.2	156	SEG(35)	2166.0	807.6	216	SEG(95)	-2394.0	807.6				
37	D5	-1333.8	-857.8	97	COM(55)	4826.0	-807.6	157	SEG(36)	2090.0	807.6	217	SEG(96)	-2470.0	807.6				
38	D4	-1232.2	-857.8	98	COM(54)	5328.4	-836.6	158	SEG(37)	2014.0	807.6	218	SEG(97)	-2546.0	807.6				
39	D3	-1130.6	-857.8	99	COM(53)	5328.4	-760.6	159	SEG(38)	1938.0	807.6	219	SEG(98)	-2622.0	807.6				
40	D2	-1029.0	-857.8	100	COM(52)	5328.4	-684.6	160	SEG(39)	1862.0	807.6	220	SEG(99)	-2698.0	807.6				
41	D1	-927.4	-857.8	101	COM(51)	5328.4	-608.6	161	SEG(40)	1786.0	807.6	221	SEG(100)	-2774.0	807.6				
42	D0	-825.8	-857.8	102	COM(50)	5328.4	-532.6	162	SEG(41)	1710.0	807.6	222	SEG(101)	-2850.0	807.6				
43	D0	-724.2	-857.8	103	COM(49)	5328.4	-456.6	163	SEG(42)	1634.0	807.6	223	SEG(102)	-2926.0	807.6				
44	CLK	-622.6	-857.8	104	COM(48)	5328.4	-380.6	164	SEG(43)	1558.0	807.6	224	SEG(103)	-3002.0	807.6				
45	CLK	-521.0	-857.8	105	COM(47)	5328.4	-304.6	165	SEG(44)	1482.0	807.6	225	SEG(104)	-3078.0	807.6				
46	CE	-419.4	-857.8	106	COM(46)	5328.4	-228.6	166	SEG(45)	1406.0	807.6	226	SEG(105)	-3154.0	807.6				
47	DVDD:	-317.8	-857.8	107	COM(45)	5328.4	-152.6	167	SEG(46)	1330.0	807.6	227	SEG(106)	-3230.0	807.6				
48	DVDD:	-216.2	-857.8	108	COM(44)	5328.4	-76.6	168	SEG(47)	1254.0	807.6	228	SEG(107)	-3306.0	807.6				
49	DVSS:	-114.6	-857.8	109	COM(43)	5328.4	-0.6	169	SEG(48)	1178.0	807.6	229	SEG(108)	-3382.0	807.6				
50	DVSS:	-13.0	-857.8	110	COM(42)	5328.4	75.4	170	SEG(49)	1102.0	807.6	230	SEG(109)	-3458.0	807.6				
51	AVDD:	138.4	-857.8	111	COM(41)	5328.4	151.4	171	SEG(50)	1026.0	807.6	231	SEG(110)	-3534.0	807.6				
52	AVDD:	244.4	-857.8	112	COM(40)	5328.4	227.4	172	SEG(51)	950.0	807.6	232	SEG(111)	-3610.0	807.6				
53	AVSS:	350.4	-857.8	113	COM(39)	5328.4	303.4	173	SEG(52)	874.0	807.6	233	SEG(112)	-3686.0	807.6				
54	AVSS:	456.4	-857.8	114	COM(38)	5328.4	379.4	174	SEG(53)	798.0	807.6	234	SEG(113)	-3762.0	807.6				
55	VF	562.4	-857.8	115	COM(37)	5328.4	455.4	175	SEG(54)	722.0	807.6	235	SEG(114)	-3838.0	807.6				
56	VR	668.4	-857.8	116	COM(36)	5328.4	531.4	176	SEG(55)	646.0	807.6	236	SEG(115)	-3914.0	807.6				
57	C1P	774.4	-857.8	117	COM(35)	5328.4	607.4	177	SEG(56)	570.0	807.6	237	SEG(116)	-3990.0	807.6				
58	C1N	880.4	-857.8	118	COM(34)	5328.4	683.4	178	SEG(57)	494.0	807.6	238	SEG(117)	-4066.0	807.6				
59	C2P	986.4	-857.8	119	COM(33)	5328.4	759.4	179	SEG(58)	418.0	807.6	239	SEG(118)	-4142.0	807.6				
60	C2N	1092.4	-857.8	120	COM(32)	5328.4	835.4	180	SEG(59)	342.0	807.6	240	SEG(119)	-4218.0	807.6				

Note : *Power and ground die pads should be bonded correspondingly in COG application

Die Pad 15 - 33, 43, 45, 47 -54, 64, 66, 68, 70, 72 - 73, 76, 78 and 82 - 87 are multiple pads of critical signal
(Basically, these are D0, CLK, DVDD, DVSS, AVDD, AVSS, VCC and VLL2-VLL6 which special design for COG)

Bump Size :	Pad	X(um)	Y(um)	Die Size (including scribe) :	1126.8 x 2286 (um)
	1-10	42	100		
	11-87	65	65		
	88-97	42	100		
	98-120	100	42		
	121-248	42	100		
	249-271	100	42		