

Quad Line Receiver

MC1692

ELECTRICAL CHARACTERISTICS

Characteristic	Symbol	-30°C		+25°C		+85°C		Unit
		Min	Max	Min	Max	Min	Max	
Power Supply Drain Current	I_E	—	—	—	50	—	—	mAdc
Input Current	I_{in}	—	—	—	250	—	—	μ Adc
Input Leakage Current	I_R	—	—	—	100	—	—	μ Adc
Reference Voltage	V_{BB}	-1.375	-1.275	-1.35	-1.25	-1.3	-1.2	Vdc
Switching Times Propagation Delay	t^{-+}	0.6	1.6	0.6	1.5	0.6	1.7	ns
	t^{+-}	0.6	1.8	0.6	1.7	0.6	1.9	
Rise Time, Fall Time (10% to 90%)	t^+, t^-	0.6	2.2	0.6	2.1	0.6	2.3	ns

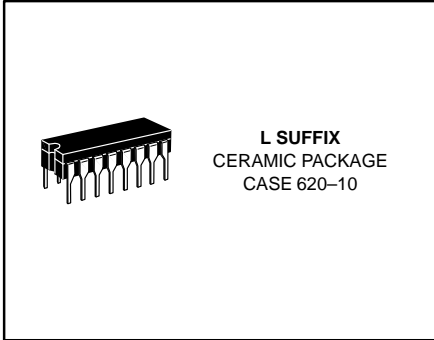

LOGIC DIAGRAM

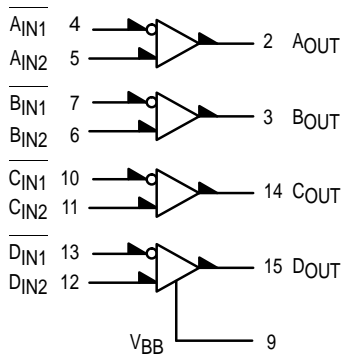

V_{CC1} = PIN 1
 V_{CC2} = PIN 16
 V_{EE} = PIN 8

t_{pd} = 0.9 ns typ (510 ohm load)
= 1.1 ns typ (50 ohm load)

P_D = 220 mW typ/pkg (No Load)
Full Load Current, I_L = -25 mAdc max

PIN ASSIGNMENT

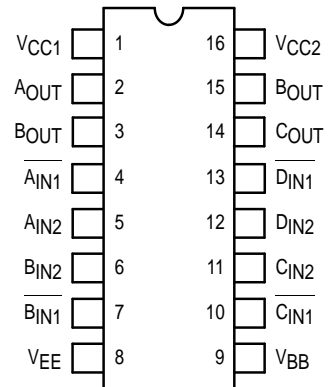

APPLICATION INFORMATION

The MC1692 quad line receiver is used primarily to receive data from balanced twisted pair lines, as indicated in Figure 1. The line is driven with a MC1660 OR/NOR gate. The MC1660 is terminated with 50 ohm resistors to -2.0 volts. At the end of the twisted pair a 100 ohm termination resistor is placed across the differential line receiver inputs of the MC1692. Illustrated in Figure 2 is the sending and receiving waveforms at a data rate of 400 megabits per second over an 18 foot twisted pair cable.

The waveform picture of Figure 3 shows a 5.0 nanosecond pulse being propagated down the 18 foot line. The delay time for the line is 1.68 ns/foot.

The MC1692 may also be applied as a high frequency schmitt trigger as illustrated in Figure 4. This circuit has been used in excess of 200 MHz. The MC1692 when loaded into 50 ohms will produce an output rising edge of about 1.5 nanoseconds.

FIGURE 1 — LINE DRIVER/RECEIVER

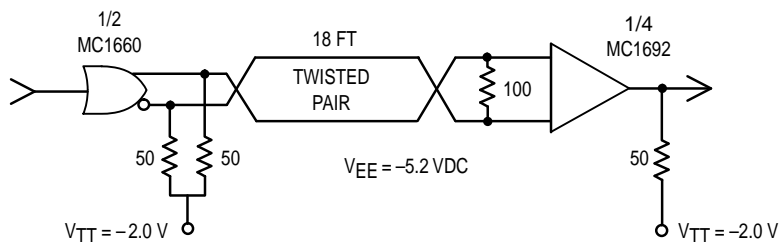

FIGURE 2 — 400 MBS WAVEFORMS

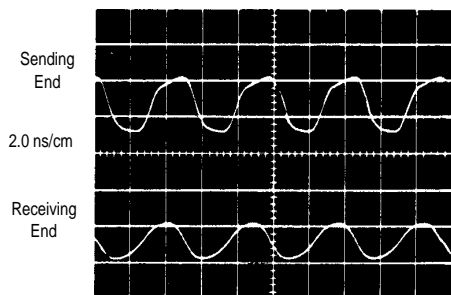

FIGURE 3 — PULSE PROPAGATION WAVEFORMS

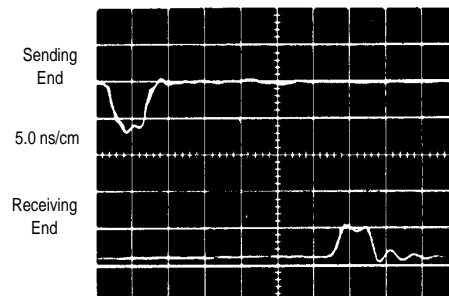
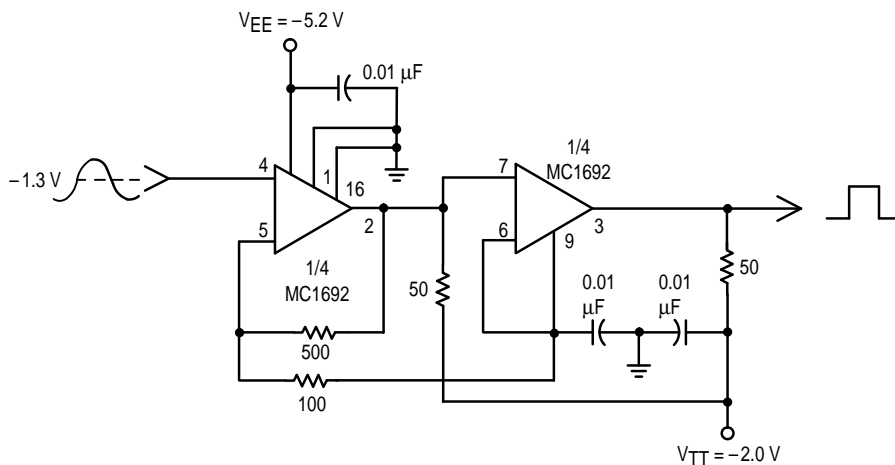
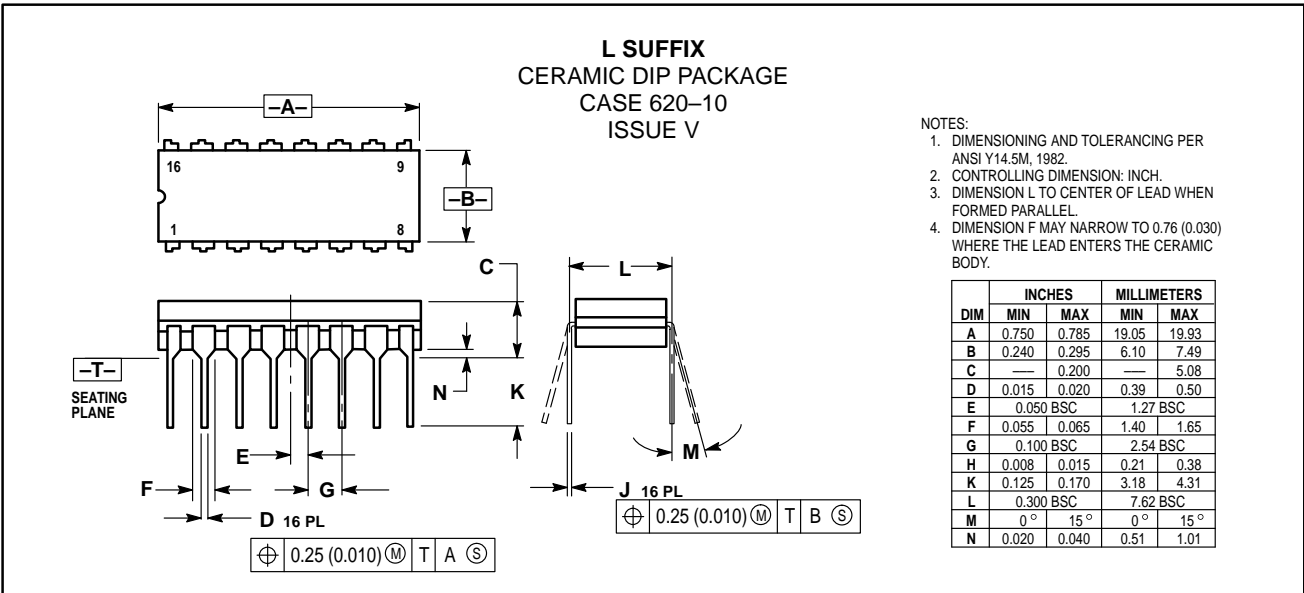

FIGURE 4 — 200 MHz SCHMITT TRIGGER



OUTLINE DIMENSIONS



Motorola reserves the right to make changes without further notice to any products herein. Motorola makes no warranty, representation or guarantee regarding the suitability of its products for any particular purpose, nor does Motorola assume any liability arising out of the application or use of any product or circuit, and specifically disclaims any and all liability, including without limitation consequential or incidental damages. "Typical" parameters which may be provided in Motorola data sheets and/or specifications can and do vary in different applications and actual performance may vary over time. All operating parameters, including "Typicals" must be validated for each customer application by customer's technical experts. Motorola does not convey any license under its patent rights nor the rights of others. Motorola products are not designed, intended, or authorized for use as components in systems intended for surgical implant into the body, or other applications intended to support or sustain life, or for any other application in which the failure of the Motorola product could create a situation where personal injury or death may occur. Should Buyer purchase or use Motorola products for any such unintended or unauthorized application, Buyer shall indemnify and hold Motorola and its officers, employees, subsidiaries, affiliates, and distributors harmless against all claims, costs, damages, and expenses, and reasonable attorney fees arising out of, directly or indirectly, any claim of personal injury or death associated with such unintended or unauthorized use, even if such claim alleges that Motorola was negligent regarding the design or manufacture of the part. Motorola and are registered trademarks of Motorola, Inc. Motorola, Inc. is an Equal Opportunity/Affirmative Action Employer.

How to reach us:

USA/EUROPE/Locations Not Listed: Motorola Literature Distribution; P.O. Box 5405, Denver, Colorado 80217. 1-800-441-2447

JAPAN: Nippon Motorola Ltd.; Tatsumi-SPD-JLDC, 6F Seibu-Butsuryu-Center, 3-14-2 Tatsumi Koto-Ku, Tokyo 135, Japan. 03-81-3521-8315

Mfax™: RMFAX0@email.sps.mot.com – TOUCHTONE 602-244-6609
INTERNET: http://Design-NET.com

ASIA/PACIFIC: Motorola Semiconductors H.K. Ltd.; 8B Tai Ping Industrial Park, 51 Ting Kok Road, Tai Po, N.T., Hong Kong. 852-26629298

